

SMITHSONIAN MISCELLANEOUS COLLECTIONS

VOLUME 72, NUMBER 13

THE MELIKERON—AN APPROXIMATELY  
BLACK-BODY PYRANOMETER

BY  
L. B. ALDRICH

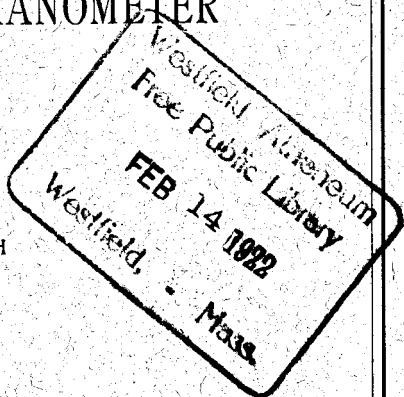

(PUBLICATION 2662)

CITY OF WASHINGTON  
PUBLISHED BY THE SMITHSONIAN INSTITUTION  
JANUARY 25, 1922

SMITHSONIAN MISCELLANEOUS COLLECTIONS

VOLUME 72, NUMBER 13

THE MELIKERON—AN APPROXIMATELY  
BLACK-BODY PYRANOMETER

BY  
L. B. ALDRICH



(PUBLICATION 2662)

CITY OF WASHINGTON  
PUBLISHED BY THE SMITHSONIAN INSTITUTION  
JANUARY 25, 1922

*The Lord Baltimore Press*  
BALTIMORE, MD., U. S. A.

# THE MELIKERON—AN APPROXIMATELY BLACK-BODY PYRANOMETER

By L. B. ALDRICH

## INTRODUCTION

The instrument about to be described is the outgrowth of the experience of Dr. Abbot and myself in the use of the pyranometer, and was planned in many discussions between us, as we walked together to and from the office. The pyranometer (described in Smithsonian Miscellaneous Collections, Vol. 66, Nos. 7 and 11, and Vol. 69, No. 9) has proved of great value in a wide range of radiation measurements. We have long felt the desirability and need, however, of a radiation measuring instrument of equal sensitiveness which would be perfectly absorbing and radiating for all wave-lengths by virtue of its form. Existing types of instruments, such as the pyranometer, bolometer, Ångström's pyrgeometer, compensation pyrliometer, etc., all use a blackened flat surface upon which the radiation falls and is mostly absorbed. For the usual range of wave-lengths, for which the percentage absorption of the blackened surface is well known, these instruments are highly satisfactory. But in measuring radiations from bodies at comparatively low temperatures, grave doubt arises [with these instruments] because of the uncertainty of the absorptive power of a blackened flat surface for rays of long wave-length.

In the new instrument we have tried to produce one embodying an approximately "black-body" absorber, and still to retain as far as possible the advantages of the simple pyranometer. The melikeron is not as sensitive nor as quick-acting as the pyranometer, yet we have been very well pleased with its behavior. A detailed description of the instrument follows.

## DESCRIPTION OF THE MELIKERON

The name of the instrument, first suggested by Dr. Abbot, is the Greek word *μελικήρογ*, honeycomb. That portion of the instrument which absorbs the radiation to be measured is somewhat like a honeycomb in shape.

Sheet therlo,<sup>1</sup> an alloy having a low temperature coefficient of resistance, was rolled out into a strip about a meter long and as thin as possible. (In the first instrument made, this strip was about 0.05 mm. in thickness. This was about the limit of thinness obtainable by rolling between cold rollers. For the second instrument, a strip of one-half this thickness was produced by rolling between hot rollers. This was done by the mechanic of the University of Wisconsin Physics Department, through the kindness of Dr. C. E. Mendenhall.) With a straight edge, the strip was cut to one-half inch in width, and then pressed out in a specially prepared die, to assume the alternately flat and zigzag shape shown in figure 3. When this long strip was held together in a square frame, there were formed 200 small triangular tubes with walls in common, each tube one-half inch in depth and about 2.5 mm. on a side. The open end of this honeycomb of triangular tubes forms the absorbing area of the instrument.

The advantage gained by the large number of cells is that the outer ones protect the inner ones from loss of heat, so that notwithstanding the very large area of the walls of the cells compared to their open ends, the central cells, losing only at front and rear, change temperature about as much as flat strips presenting equal areas would do for the same intensity of radiation. We invoke, in other words, the guard-ring principle.

Before the long, crinkled strip was pressed into this square shape, each apex was coated with thin shellac, the whole baked in an oven for some hours, and this process repeated several times. Thus the whole strip, when formed into its final shape, was insulated, each part from every other that could come in contact with it, and a current of electricity could be sent through its whole length.

On the walls of the central cluster of tubes formed by the bending of the strip were fastened four thermo-electric elements, of fine copper and nickel wire. The junctions were symmetrically placed 2.5, 5.0, 7.5 and 10.0 mm. respectively along the length of the tube and insulated from it by thin tissue paper. These wires were brought out on the lower end of the tubes and connected in series. The constant temperature junctions were buried in wax on the under side of the glass plates *f, f* (fig. 2) and the outer leads were soldered to the binding posts *a, a*, (fig. 1). The two ends of the therlo strip were connected by copper wires to binding posts *a', a'* (fig. 1).

<sup>1</sup> Obtained from the Driver-Harris Wire Co.

Referring to figures 1 and 2, we may see how the honeycomb is mounted. Figure 1 is a view looking vertically down upon the instrument with shutter (*e*) wide open. Figure 2 is a vertical cross-section. Two nickeled copper plates (*i, h*), each with square holes 3 cm. on a side are placed one about 6 mm. above the other. The plates are held

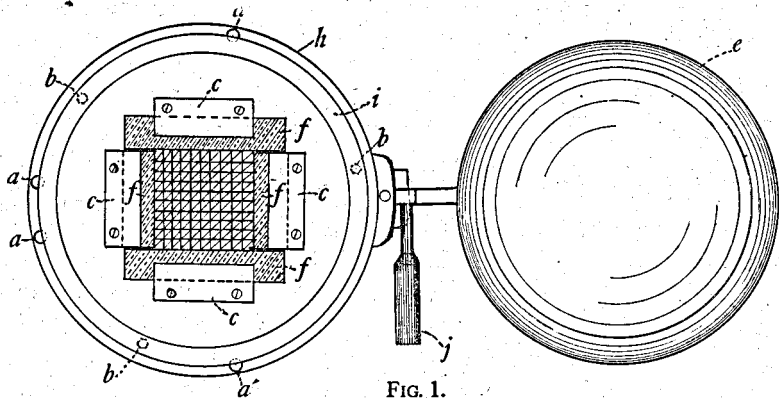

FIG. 1.

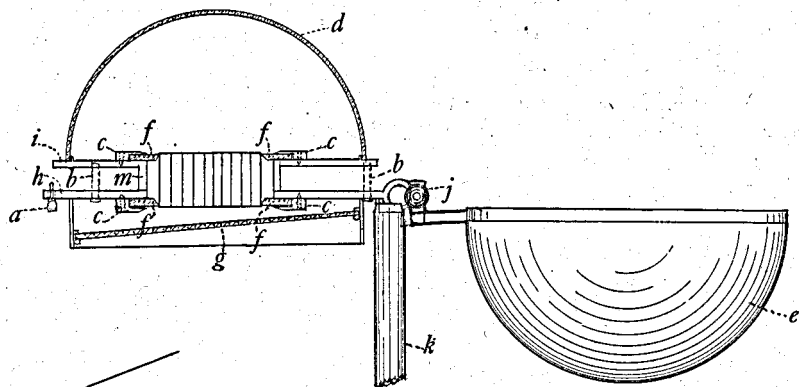

FIG. 2.

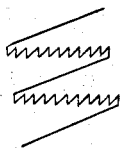

FIG. 3.

together by the three posts (*b*) and the space between the plates around the square hole enclosed with a copper box (*m*) attached to the upper plate. The wires leading to the four binding posts (*a, a, a', a'*) pass through holes in this copper box. Four nickeled copper clips (*c*) are screwed to the top of the upper plate, and four more to the bottom of the lower plate. Each of these eight clips holds in

place a silvered glass plate (*f*), each of which glass plates is beveled along its inner edge. These beveled glass edges serve to support the therlo strip in its square form, four around the upper edge of the honeycomb and four around the lower edge. The upper four also serve to determine the area which absorbs radiation. The silvered glass mirror (*g*), below the honeycomb, is placed, as shown, at a small angle to the face of the honeycomb and serves both to protect from the wind and to reflect radiation escaping from the lower face of the honeycomb back upon the sides of the tubes. The rod (*k*) screws into the plate (*h*) and affords a means of mounting the instrument in any desired position. The hemispherical shutter, (*e*), nicked on the outside and blackened inside, operates from the handle (*j*), just as in the pyranometer. The optically figured ultra-violet crown glass hemisphere (*d*) serves the same purpose as in the pyranometer and may be used or not, according to whether or not it is desired to cut off the exchange of long waves between the instrument and the object to which it is exposed.

The melikeron is similar to the pyranometer in principle. In place of a small flat absorbing surface we substitute a large absorbing area consisting of the above described honeycomb of triangular tubes. Radiation falling normally passes through and is reflected back upon the walls by the rear mirror. Radiation not falling normally strikes the walls of the tubes and after one or more reflections is absorbed. For the purpose of somewhat increasing the blackness of the honeycomb, only the lower two-thirds of each tube is painted with lampblack, the upper one-third remaining a metallic reflector. Thus the number of regular reflections before final absorption is increased and the loss by diffuse reflection near the upper end reduced, because the diffusely reflecting and radiating lampblack lies so far below the aperture that the latter subtends only a small angular area as viewed from the blackened surface.

#### METHOD OF USE

For nocturnal radiation, or for the measurement of radiation exchange between the instrument and an object at lower temperature, the melikeron is used like the pyranometer. That is, an electric current is passed into the therlo strip producing heat sufficient to exactly compensate for the loss of heat by radiation. Knowing the current used, the resistance of the strip, and the other constants of the instrument, the amount of heat radiated is computed as with the pyranometer.

For measurements on the sun, daylight sky, or any radiation from bodies at higher temperature than the instrument, the simple "first-swing" pyranometer method is not applicable, since the slow-acting melikeron prevents a definite first-swing of the galvanometer and requires several minutes to complete the galvanometer deflection. An almost equally simple and satisfactory method applicable to constant sources of radiation was suggested by Dr. Abbot, however, namely: To open the shutter and expose to the radiation to be measured until the galvanometer deflection is constant, then close the shutter and instantly introduce sufficient current to keep the galvanometer at the same reading.

#### CONSTANTS OF INSTRUMENTS AND TESTS MADE

As mentioned above, two copies of the melikeron have been made. The second instrument embodies several improvements, notably a thinner therlo strip, and the tipping of the rear mirror at a slight angle to the honeycomb face. The constant of each instrument and tests made with each are given below.

*Melikeron No. 1.*—The constant of the instrument may be obtained in two ways:

- (1) By computation from the dimensions and properties of the instrument;
- (2) By direct comparisons on the sun with a silver disk pyrheliometer or other standardized instrument.

Only the first of these methods was used for the constant of Melikeron No. 1. As compared with the second method, this method is difficult and inaccurate, because of the uncertainty of such corrections as the amount reflected from the end surfaces of the thin metal composing the tubes, the amount lost by reflection and radiation from the upper portion of the tubes, the decrease in total aperture due to the unavoidable indentations around the edge, etc. A rough determination was made of the computed constant of Melikeron No. 1, as follows:

Area of aperture formed by beveled glass edges = 5.83 cm.<sup>2</sup>

Estimated decrease in area of unused portions = .30 "

Corrected area = 5.53 "

Resistance of therlo strip = 0.945 ohms.

Then  $\frac{.945 \times 60}{4.183 \times 5.53} = 2.45 = \text{constant Melikeron No. 1, applicable to reduce } C^2 \text{ readings to calories per } \left(\frac{\text{cm.}^2}{\text{min.}}\right)$ .

This is the constant without the glass hemisphere. *With* glass hemisphere, allowing for the reflection loss at two glass surfaces, the con-



stant becomes 2.66 for the rays of short wave-length for which glass is highly transmissible.

Test experiments of three kinds were made with Melikeron No. 1:

(1) Using an incandescent lamp source, comparisons were made by interchanging Melikeron No. 1 and Pyranometer A. P. O. No. 5.

TABLE I

Date, 1920	Conditions	Calories (by melik- eron No. 1)	Calories (by pyran- ometer No. 5)	Ratio melikeron pyranom- eter
Feb. 11..	Carbon lamp, 60 cm directly above..	.0538	.0648	.830
Feb. 12..	Same, except angle 25° from zenith.	.0522	.0537	.972
Feb. 13..	Mazda "Daylight" lamp, 30 cm. above, 13° from zenith.	.0558	.0562	.995
Feb. 13..	Same source, 8 cm. above and 25 cm. east, 72° from zenith.	.0245	.0237	1.033
Feb. 14..	Same source, 30 cm. above, 7½° from zenith.	.0502	.0517	.972
Feb. 14..	Same source, 30 cm. above, 4½° from zenith.	.0435	.0512	.850

Both instruments were leveled, and the source placed at varying angles and distances. To insure constancy of the source, storage batteries were used. The results are summarized in table I.

As would be expected, since in Melikeron No. 1 the rear mirror is perpendicular to the honeycomb tubes, the instrument does not measure the full amount of radiation falling *normally* or nearly so, for this passes through the tubes to the rear mirror and is reflected by it directly back without being absorbed. For incidence greater than

TABLE II  
(February 18, 1920)

	(Current) <sup>2</sup> by melikeron No. 1	(Current) <sup>2</sup> by pyrgeometer No. 22	Calories by melikeron	Constant of pyrgeometer No. 22
With R. S. plate .....	.01334	.00304	.0327	10.85
No " " .....	.01756	.00350	.0430	12.28
With " " .....	.01284	.00286	.0314	10.97
No " " .....	.01246	.00282	.0305	10.81
No " " .....	.01483	.00313	.0364	11.61
No " " .....	.01573	.00314	.0385	12.26
With " " .....	.01096	.00259	.0269	10.40
No " " .....	.01309	.00256	.0321	12.55

Mean constant No. 22 with R. S. = 10.78.  
Mean constant No. 22 no R. S. = 12.18.

5 degrees from normal, however, good agreement is shown between the pyranometer and the melikeron.

(2) Comparisons were made between Melikeron No. 1 and Ångström Pyrgeometer No. 22, with and without the interposition of a rock salt plate. A flat copper vessel (fig. 4) 90 x 86 cm., blackened on the front surface by painting with lampblack-alcohol-shellac paint and filled with ice-cooled water, formed the source, the instruments being at room temperature. A double shutter (*s*), sliding horizontally close to the copper vessel, exposed or screened the source. The instruments could be quickly exchanged, each mounted with absorbing

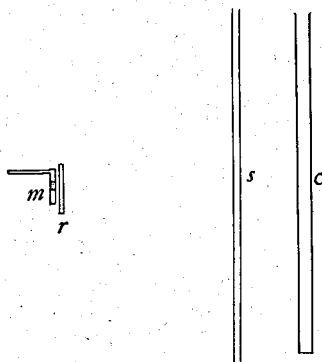

FIG. 4.

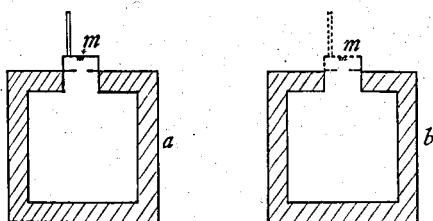

FIG. 5.

surface vertical, facing the copper vessel, and 65 cm. from it. Alternate comparisons were made with and without a 1 cm. rock salt plate (*r*), figure 4, interposed directly in front of the instrument aperture. Using the above computed constant of the melikeron, values of the constant of Pyrgeometer No. 22 were determined (table II).

The absolute value of these results is of little weight, but the markedly lower value of the constant of Pyrgeometer No. 22 for the case where waves longer than  $20\mu$  are excluded, seems to indicate the greater "blackness" of the melikeron as compared with the other instrument for rays of very great wave-length.

(3) A rough determination of the constant  $\sigma$  of Stefan's formula was made. A wooden case and water jacket were fitted around Melikeron No. 1 to protect it from temperature fluctuations of the surroundings. This jacket extended over the face of the instrument, leaving an aperture 3.64 cm. in diameter at 7.03 cm. from the honey-comb face. Two hollow-chamber black bodies were made of double walled galvanized iron vessels (*a* and *b*, fig. 5) filled between the walls with stirred water, one at room temperature, the other containing a mixture of ice and water. The melikeron and surrounding jacket just filled the aperture of either of these black bodies, and could be quickly moved from one to the other aperture. The results are summarized. Details and necessary corrections which have been introduced in these results here will be found in the forthcoming Vol. IV, Annals of the Astrophysical Observatory.

Temperature of		(Current) <sup>2</sup>	Observed calories $\left(\frac{\text{cm.}^2}{\text{min.}}\right)$	$\sigma$ (calories per cm. <sup>2</sup> per min.)
B. B. "a"	B. B. "b"			
19.63	0.44	.003807	.00954	$8.45 \times 10^{-11}$ (Mean of 7)
28.30	0.40	.005852	.01434	$8.53 \times 10^{-11}$ (Mean of 7)

Value usually accepted (Smith. Phys. Tables, 7, p. 247)  $8.26 \times 10^{-11}$ .

These values are not given as new determinations of sigma. They have little weight for this purpose. They are given to show that not only does the melikeron agree with the standardized pyranometer for short-wave radiation observations but it also agrees well with the best work for long-wave rays.

*Melikeron No. 2.*—The constant of this instrument was determined with more care, and by both methods above mentioned.

(1) Computed constant.

Area of aperture formed by beveled glass edges =  $2.42 \times 2.42 = 5.86 \text{ cm.}^2$

Therlo strip = 80 cm. long and .003 thick, making an end cross-sectional area of  $0.24 \text{ cm.}^2$

Assume 40 per cent loss by reflection from this edge and this correction becomes  $.096 \text{ cm.}^2$

Area of incomplete triangles along edge of aperture =  $0.36 \text{ cm.}^2$

Radiation entering  $\frac{1}{2}$  this area is lost =  $0.18 \text{ cm.}^2$

Assume direct absorption for solar rays<sup>1</sup> of thermo strip = 70 per cent, then of the other 18 cm.<sup>2</sup> 30 per cent is lost = .054 cm.<sup>2</sup> Hence, the total correction for incomplete triangles is .054 + .18 = .234 cm.<sup>2</sup>

Area of irregular indentations that can lose energy by direct radiation = .06 cm.<sup>2</sup>

Of this,  $\frac{1}{2}$  is lost = .03 cm.<sup>2</sup> (because radiation from one side of perpendicular is lost, other side is absorbed).

Total losses of all kinds = .096 + .234 + .03 = .36 cm.<sup>2</sup>

Corrected area = 5.86 - .36 = 5.50 cm.<sup>2</sup>

Resistance of strip = 1.555 ohms.

Computed constant (without glass hemisphere) =

$$\frac{1.555 \times 60}{4.183 \times 5.50} = 4.05$$

## (2) Observed Constant.

The constant determined by comparison with pyrhelimeters may be given more weight. The melikeron was mounted equatorially and a hood placed around it, similar to that supplied with the pyranometer, exposing the instrument only to the sun and a small area of sky around it. A double, ventilated shutter, blackened below, served to cut off the radiation at intervals. The first comparison was made on Mount Wilson, California, August 29 and 30, 1920, using secondary pyrhelimeter No. IV. All the following values are *without* glass hemisphere.

First determination—Melikeron mounted so that sun rays fall normally on the instrument.

$$\text{Calories by Pyr. No. IV} \left( \text{per } \frac{\text{cm.}^2}{\text{min.}} \right) = 1.468 \text{ (mean of 3).}$$

$$(\text{Current})^2 \text{ of Melikeron} = .348 \text{ (mean of 3).}$$

$$\frac{1.468}{.348} = 4.22 = \text{constant Melikeron No. 2.}$$

Second determination—Melikeron mounted so that sun rays strike the instrument at an angle of 8° 5' (cos. = .989).

$$\text{Calories by Pyr. No. IV} = 1.437 \text{ (mean of 3).}$$

$$(\text{Current})^2 \text{ of Melikeron} = .360 \text{ (mean of 3).}$$

$$\frac{1.437 \times .989}{.360} = 3.95 = \text{constant of Melikeron No. 2.}$$

From the ratio of these two results it appears that 6.8 per cent of the *normal* beam is absorbed and scattered, probably largely by

<sup>1</sup> For rays of great wave-length the absorption is much less, so that this part of the loss would be increased. The difference cannot be serious, however, because this correction is after all very small.

the silvered surface of the rear mirror. Thus 3.95 is regarded as more nearly correct for ordinary work with beams which (unlike direct run-rays) subtend large angles.

The second comparison was made at Mount Harqua Hala, Arizona, by Dr. Abbot, November 10, 1920, using secondary pyrheliometers S. I. No. 32 and A. P. O. No. 9.

First determination—Melikeron normal to sun's rays.

Calories by Pyr. No. 32 and No. 9 = 1.531 (mean value).

(Current)<sup>2</sup> of Melikeron = .347 (mean value).

$$\frac{1.531}{.347} = 4.41 = \text{constant of Melikeron No. 2.}$$

Second determination—Melikeron at 7° angle to sun's rays (cos. 7° = .992).

Calories by Pyr. No. 32 and No. 9 = 1.538 (mean value).

(Current)<sup>2</sup> of Melikeron = .378

$$\frac{1.538 \times .992}{.378} = 4.04 = \text{constant of Melikeron No. 2.}$$

This result shows for *normally* incident rays a considerably greater absorption and scattering by the rear mirror than was the case in the comparison of August 30. From the deteriorated appearance of the silvered mirror on November 10 this was quite to be expected for sun rays, but the deterioration was probably quite negligible for earth rays. The best constant, then, of Melikeron No. 2 without glass hemisphere is the mean of 3.95 and 4.04, or 4.00 which is now the adopted value, applicable for all rays not at strictly *normal* incidence.

At Mount Wilson and Mount Harqua Hala numerous comparisons on the night sky were made between Melikeron No. 2 and Pyrgeometer No. 22. The two instruments, leveled, were mounted at the same height and within less than 6 inches of each other. Exactly similar bright tin-box shutters were used on both instruments. Using the above adopted constant of Melikeron No. 2, a value of the constant of Pyrgeometer No. 22 was obtained each time. The results are summarized in table III.

The mean of all, under these varying conditions of air temperature and water-vapor content is 9.72. There is perhaps some evidence in these values that the constant of Pyrgeometer No. 22 is a function of both air temperature and water-vapor content. But further comparisons under a wider range of air conditions are needed to confirm it.

To illustrate this indication, values are given in the table computed by the formula:

$$\text{Constant} = 11.50 - 3.12p - 1.47 (t - 60^\circ)^{1/2}.$$

They fit the observations much closer than the mean. This would be expected. To increase either the humidity or the temperature is to diminish the proportion of the extreme long-wave rays. The insertion of the salt plate in the above reported experiments with Melikeron No. 1 had a similar tendency. Hence, in view of the earlier observa-

TABLE III

Date, 1920	Wet and dry ( $t$ ) readings, F.		Pressure aqueous vapor ( $p$ ) mm.	Constant of pygeometer No. 22	$\Delta$ from mean	Computed value	o-c
	Wet	Dry					
Mt. Wilson							
August 25 .....	{ 45.0 45.7	{ 48.6 48.4	{ 7.1 7.3	9.36	-0.36	9.59	-0.23
August 27 .....	{ 50.1 49.5	{ 58.3 57.3	{ 7.3 7.2				
August 28 .....	{ 52.0 48.3	{ 58.2 58.0	{ 8.5 6.4	9.29	-0.43	9.03	+0.26
August 28 .....	{ 46.0 45.5	{ 58.0 58.2	{ 5.1 4.8	9.78	+0.06	9.90	-0.12
August 28 .....	{ 45.0 45.0	{ 57.3 57.3	{ 4.8 4.8				
Mt. Harqua Hala							
September 29...	{ 53.0 53.0	{ 70.5 70.2	{ 6.2 6.3	9.40	-0.32	9.23	+0.17
September 30...	{ 47.6 48.7	{ 69.0 67.0	{ 3.3 4.5				
October 1.....	{ 50.0 50.0	{ 64.3 64.3	{ 5.9 5.9	9.36	-0.36	9.42	-0.06
October 2.....	{ 45.9 45.9	{ 63.5 62.3	{ 3.8 4.1				
October 3.....	{ 49.5 49.2	{ 66.0 65.5	{ 5.1 5.1	9.95	+0.23	9.65	+0.30

tions, from the analogy, we should expect by increasing humidity or temperature to reduce the observed pygeometer constant. The observations are in harmony with this view.

It is hoped many further experiments with the melikeron may soon be made with a view to a better knowledge of the behavior of long wave-length radiation in our atmosphere and as emitted by bodies at low temperatures.