

WENTY-THIRD EDITION.

PART FIVE

JAMES W. QUEEN.

SAMUEL L. FOX.

REFERENCE

PRICED AND ILLUSTRATED CATALOGUE

AUG 22 1938

AND

DESCRIPTIVE MANUAL

OF

MATHEMATICAL INSTRUMENTS,

FOR

DRAWING, SURVEYING AND CIVIL ENGINEERING.



MADE BY

**JAMES W. QUEEN & CO.,**

MANUFACTURING OPTICIANS,

924 Chestnut Street, Philadelphia.

1868.

PRINTED BY HENRY B. ASHMEAD, SANSON ST. ABOVE ELEVENTH.

5/23/68

## NOTICE.

### TERMS CASH.

The numerical arrangement adopted in this Catalogue renders it necessary, in ordering any of the articles enumerated, merely to give the number, with the price and edition of the Catalogue. No other description is required.

Charge will be made for boxes; and all packing will be done with the utmost care; but no responsibility will be assumed for breakage or other damage after a package leaves our premises.

The safest remittance of money is by a bank-draft, payable to our order; or, where that cannot be obtained, gold or United States notes can be sent with safety by any of the express companies. The sender must pay the charges made by the express company.

Postage-stamps or Post-office orders are equal to cash, and are readily transmitted in a letter. They will be received in any amount.

Goods ordered per express, and bill to be paid to express company, will be charged with the collection demanded by the company. **Orders of this kind must be accompanied with a remittance of five dollars.**

Goods ordered to be sent by mail must be prepaid; therefore the postage must be included in the remittance.

Having great facilities for manufacturing Mathematical and Philosophical Instruments, we are prepared to furnish, at short notice, any piece of apparatus illustrated or described in the catalogues of other makers or dealers, though it may not be specified in this Catalogue.

JAMES W. QUEEN & CO.,

924 CHESTNUT STREET.

PHILADELPHIA, *May*, 1868.

N. B.—A liberal discount to dealers.

C 62,1,1085

Q4

1868

MHT

6346-7



# CATALOGUE.

## MATHEMATICAL INSTRUMENTS.

OF BRASS. FOR SCHOOLS.

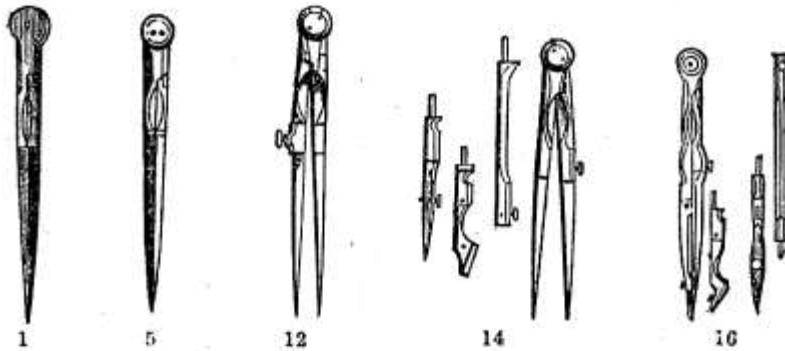

No.	Description	Price
1.	Dividers, Brass, brass joints, rivet heads, 5 inches long,	\$0 15
2.	" " " " " 6 " "	25
3.	" " steel joints, screw heads, 5 " "	30
4.	" " " " " 6 " "	40
5.	" " brass joints, turned cheeks, 3 inches long,	30
6.	" " " " " 4 " "	40
7.	" " " " " 5 " "	50
8.	" " " " " 6 " "	65
9.	" " steel " " " 4 " "	65
10.	" " " " " 5 " "	85
11.	" " " " " 6 " "	1 00
12.	" " " " " 5 " with hair spring,	1 25
13.	" " " " " 6 " "	1 65
14.	Dividers, Brass, brass joints, turned cheeks, 4½ inches long, with Pen, and Pencil Points and Lengthening Bar, per set,	1 00
15.	Dividers, Brass, brass joints, turned cheeks, 6 inches long, with Pen and Pencil Points and Lengthening Bar, per set,	1 00
16.	Dividers, Brass, brass joints, turned cheek, needle point, 4½ inches long, with Pen and Pencil Points and Lengthening Bar, per set,	1 25
17.	Dividers, Brass, brass joints, turned cheeks, needle point, 6 inches long, with Pen and Pencil Points and Lengthening Bar, per set,	1 50

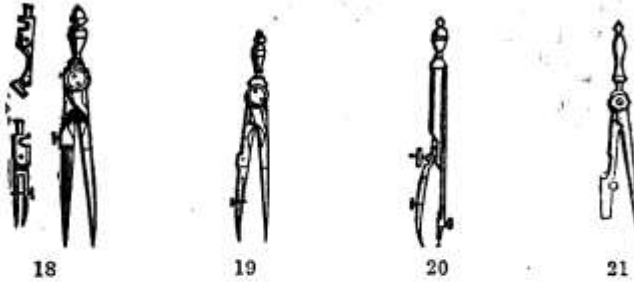

No.	PRICE.
18. Dividers, Brass, brass joints, turned cheeks, 3 inches long, with Pen and Pencil Points, per set, . . . . .	\$0 75
19. Bow Pen, brass, no spring, . . . . .	75
20. " " with adjusting screw and spring, . . . . .	1 00
21. Bow Pencil, brass, no spring, . . . . .	75

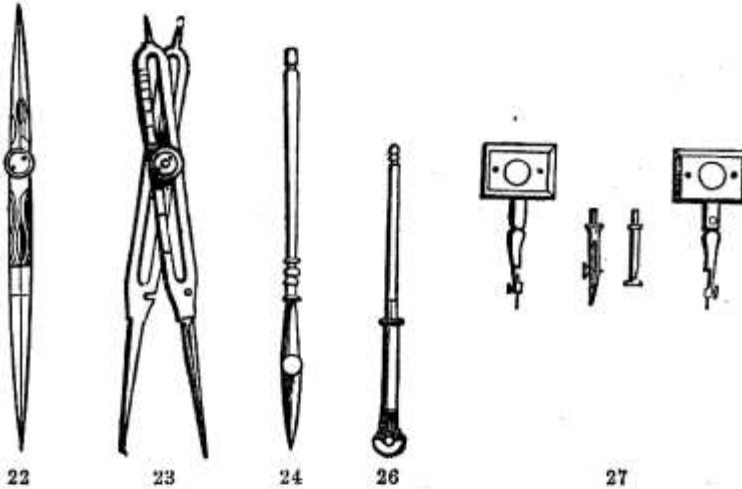

22. Bisecting Dividers, brass, . . . . .	75
23. Proportional Dividers, brass, half divided, . . . . .	2 50
24. Drawing Pen, black handle, . . . . .	35
25. " " ivory " . . . . .	50
26. Roulette for dotting lines, with extra wheels, . . . . .	1 50
27. Furniture for Beam Compass, brass, with adjusting screw, in morocco case, per set, . . . . .	6 00
28. Double Drawing or Railroad Pen, for parallel lines, brass mounted, . . . . .	2 50

## CASES OF BRASS DRAWING INSTRUMENTS.

### FOR SCHOOLS.

48. Wood Box; pair $4\frac{1}{2}$ inch Dividers, with Pen and Pencil Points, and Crayon Holder, per set, . . . . .	1 00
49. Wood Box; pair $4\frac{1}{2}$ inch Dividers, with Pen and Pencil Points and Lengthening Bar. Ebony handle Drawing Pen. Boxwood Scale, 4 inches long, per set, . . . . .	1 50



63.16.54

MATHEMATICAL INSTRUMENTS. 3

- No. 50. Wood Box; pair of  $4\frac{1}{2}$  inch Dividers, with Pen and Pencil Points and Lengthening Bar.  
 Pair of  $3\frac{1}{2}$  inch plain Dividers.  
 Drawing Pen.  
 Horn Protractor.  
 Boxwood Scale, 4 inches long, per set, . . . . . \$1 75

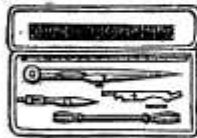

48

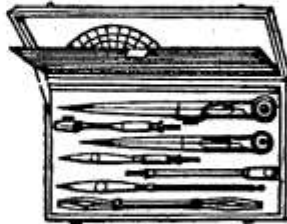

50

51. Rosewood Box; pair of  $5\frac{1}{2}$  inch Dividers, with Pen and Pencil Points and Lengthening Bar.  
 Pair of  $4\frac{1}{2}$  inch plain Dividers.  
 Drawing Pen.  
 Horn Protractor.  
 Boxwood Scale, 6 inches long, per set, . . . . . 2 50  
 52. Same as No. 51, with Parallel Ruler, per set, . . . . . 2 85  
 53. Rosewood Box; pair of  $5\frac{1}{2}$  inch Dividers, with Pen and Pencil Points and Lengthening Bar.  
 Pair of  $4\frac{1}{2}$  inch plain Dividers.  
 Drawing Pen.  
 Horn Protractor.  
 Ivory Scale, 6 inches long, per set, . . . . . 3 00  
 54. Same as 53, with addition of Parallel Ruler, per set, . . . . . 3 35

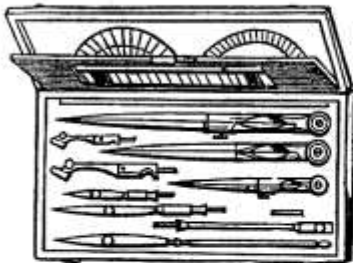

55

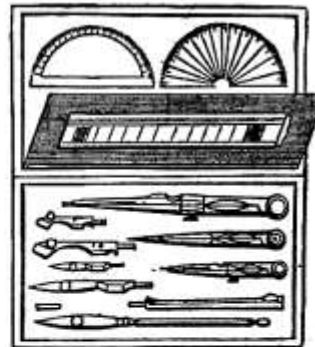

57

55. Rosewood Box; pair of 6 inch Dividers, with Pen and Pencil Points and Lengthening Bar.  
 Pair of  $4\frac{1}{2}$  inch plain Dividers.  
 Pair of  $3\frac{1}{2}$  inch Dividers, with Pen and Pencil Points.  
 Drawing Pen.  
 Brass Protractor.  
 Horn Protractor.  
 Ivory Scale, 6 inches long, per set, . . . . . 3 50  
 56. Same as No. 55, but with the instruments set in a tray, so that colors, etc., may be put below, per set, . . . . . 3 75

No.	PRICE.
57. Rosewood Box; pair of 6 inch needle point Dividers, with Pen and Pencil Points, and Lengthening Bar. Pair of $4\frac{1}{2}$ inch plain Dividers. Pair of $3\frac{1}{2}$ inch needle point Dividers, with Pen and Pencil Points. Drawing Pen. Brass Protractor. Horn Protractor. Ivory Scale, 6 inches long, per set,	\$3 75
58. Same as No. 57, but with lock and key add the instruments set in a tray, so that colors may be put below, per set,	4 00
59. Same as No. 58, with addition of Parallel Ruler, per set,	4 35
62. Rosewood Box, with lock and key, the instruments set in a tray, so that colors, etc. may be put below; pair of 6 inch needle point Dividers, with Pen and Pencil Points, and Lengthening Bar. Pair of $4\frac{1}{2}$ inch plain Dividers. Pair of $3\frac{1}{2}$ inch Needle Point Dividers, with Pen and Pencil Points. Spring Bow Pen, with Needle Point. Drawing Pen. Brass Protractor. Horn Protractor. Ivory Scale, 6 inches long, per set,	5 00
63. Same as No. 62, with addition of Parallel Ruler, per set,	5 30
64. Same as No. 62, with the addition of a pair of Proportional Dividers, per set,	7 50

**MATHEMATICAL INSTRUMENTS.**  
OF GERMAN SILVER FOR ACCURATE DRAFTING.

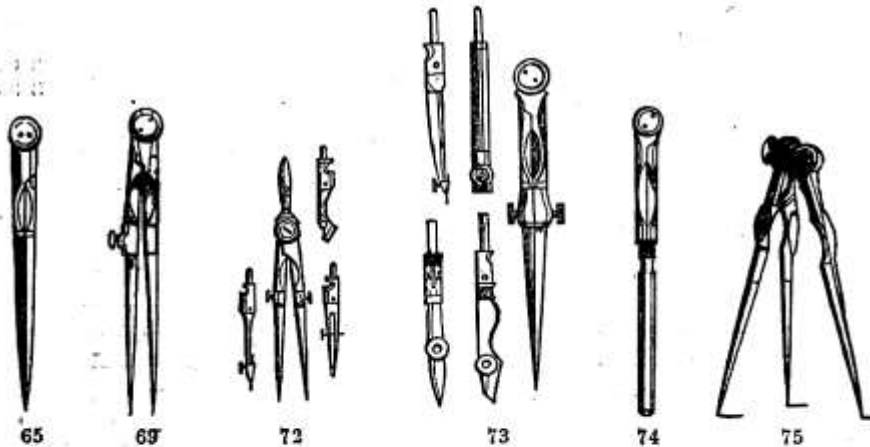

65. Dividers, German Silver, steel joints, 4 inches long,	85
66. " " " " 5 " "	1 10
67. " " " " 6 " "	1 25
68. " " " " 7 " "	1 75
69. " " " " 4 " " with hair spring,	2 00
70. " " " " 5 " " " " "	2 50
71. " " " " 6 " " " " "	3 00
72. " " " 3 inches long, with Pen, Pencil, and Needle Points, per set,	3 50
73. Dividers, German Silver, steel joints, 6 inches long, with Pen, Pencil, and Needle Points, and Lengthening Bar,	4 50
74. Dividers, German Silver, steel joints, 5 inches long, with shield for the pocket,	2 75
75. " " " " 5 inches long, with three legs,	4 75

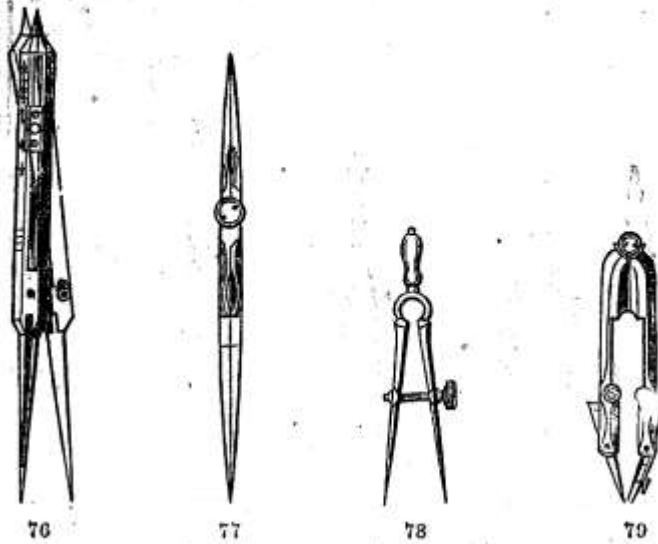

No.	PRICE.
75½. Proportional Dividers, German Silver, 7½ inches long, divided for lines,	\$3 50
76. Proportional Dividers, German Silver, 9 inches long, finely divided for lines and circles,	12 00
77. Bisecting Dividers, German Silver,	1 50
78. Spacing Dividers, all steel, with spring and adjusting screw,	1 75
79. Pocket Dividers, German Silver, with folding Pen and Pencil Points,	6 50

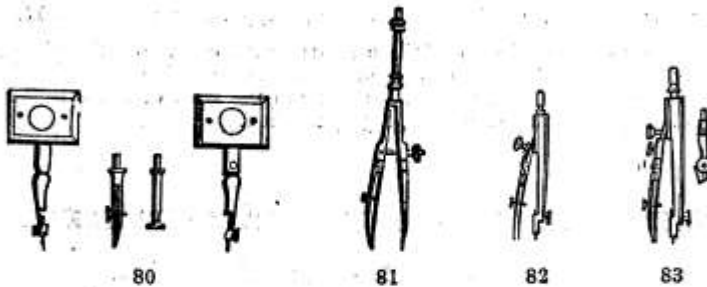

80. Furniture for Beam Compasses, German Silver, with adjusting screw, in morocco case, per set,	7 00
81. Bow Pen, all steel, with spring and adjusting screw,	2 25
82. " German Silver, with spring and adjusting screw,	2 00
83. " " " " and with Pencil Point,	3 30

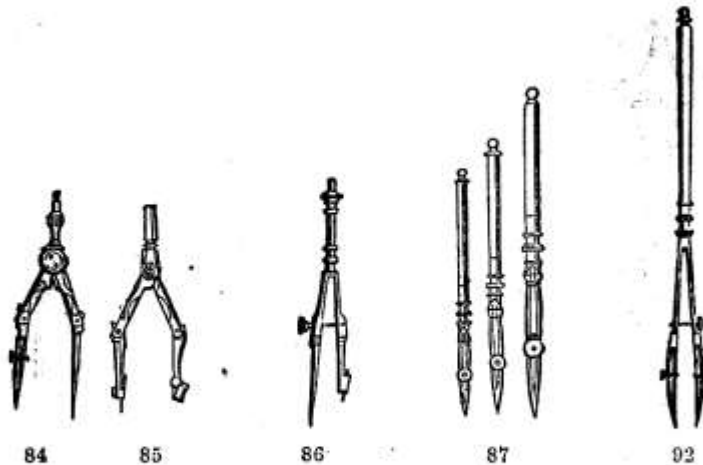

No.	PRICE.
84. Bow Pen, German Silver, no spring, Needle Point, jointed in each leg,	\$3 25
85. Bow Pencil, " " " " " " "	3 25
86. " all steel, with spring and adjusting screw, . . . . .	2 25
87. Drawing Pen, medium finish, hinge to Pen, . . . . .	75
88. " fine finish, " " . . . . .	85
89. " German Silver; fine finish, hinge to pen, and protracting pin,	1 00
90. " German Silver; fine finish, hinge to pen, and protracting pin, extra fine, . . . . .	1 75
91. " German Silver; fine finish, hinge to pen, German Silver points, for red ink, . . . . .	1 00
92. Double Drawing Pen (See No. 28, page 2), . . . . .	2 50
93. " " or Railroad Pen, for parallel lines, German Silver, fine finish, . . . . .	3 25
94. Roulette, for dotting lines, . . . . .	1 00
95. Map Perambulator, for measuring the length of curved lines, rivers, rail- roads, &c., on maps, each, . . . . .	2 50

*For Boxwood and Ivory Scales, Protractors, &c., &c., see pages 16 and 17.*

Parties wanting cases made up of these Instruments, can select the pieces, by the above list, that are best adapted to their purpose, and we will have boxes made to suit, at an additional cost of from \$7 to \$15, according to the sizes of the boxes, which are made of rosewood, mahogany or walnut, highly finished.

### CASES OF FINE GERMAN SILVER INSTRUMENTS,

For Engineers, Architects, and Machinists.

100. Morocco Box; pair of $5\frac{1}{2}$ inch Dividers, with Pen and Pencil Points. Drawing Pen. Ivory Scale, 6 inches long, per set, . . . . .	4 50
101. Morocco Box; pair of 3 inch Dividers, with Pen, Pencil and Needle Points, and Lengthening Bar. Drawing Pen. No Scale or Protractor, per set, . . . . .	5 50

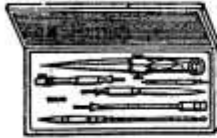

101

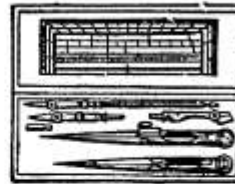

102

- | No.  | PRICE. |
|--|--------|
| 102. Morocco Box; pair of $5\frac{1}{2}$ inch Dividers, with Pen and Pencil Points.<br>Pair of 5 inch plain Dividers.<br>Drawing Pen.<br>Ivory Protractor Scale, 6 inches long, per set, . . . . .   | \$5 75 |
| 103. Same as No. 102, with addition of Needle Points and Lengthening Bar to $5\frac{1}{2}$ inch Dividers, per set, . . . . .   | 7 75   |
| 104. Morocco Box; rounded corners, for carrying in the pocket; pair of $4\frac{3}{4}$ inch Dividers, with hinge in one leg, Needle Points, with Pen and Pencil Points, and Lengthening Bar,<br>Pair of 4 inch plain Dividers, rounded points.<br>Spring Bow Pen, Needle Point.<br>Drawing Pen, ivory handle.<br>5 inch Ivory Inch Rule, divided to eighths, per set, . . . . . | 7 75   |

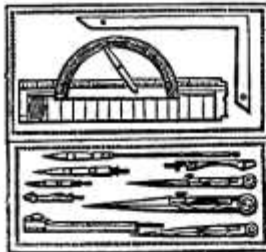

105

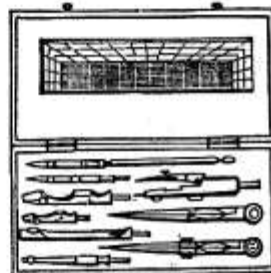

106

- |  |       |
|--|-------|
| 105. Morocco Box; pair of $5\frac{1}{2}$ inch Dividers, with Pen and Pencil Points, and Lengthening Bar.<br>Pair of 5 inch plain Dividers.<br>Pair of 3 inch Dividers, with Pen and Pencil Points.<br>Drawing Pen.<br>German Silver Protractor.<br>German Silver Square.<br>Ivory Scale, 6 inches long, per set, . . . . .                   | 10 80 |
| 106. Morocco Box; pair of $5\frac{1}{2}$ inch Dividers, with Pen, Pencil and Needle Points, and Lengthening Bar.<br>Pair of 5 inch plain Dividers.<br>Spring Bow Pen.<br>Drawing Pen.<br>Ivory Protractor Scale, 6 inches long, per set, . . . . .   | 10 80 |
| 107. Morocco Box; pair of $5\frac{1}{2}$ inch Dividers, with Pen, Pencil and Needle Points and Lengthening Bar.<br>Pair of 5 inch plain Dividers.<br>Pair of 3 inch Dividers, with Pen, Pencil, and Needle Point.<br>2 Drawing Pens.<br>German Silver Protractor.<br>German Silver Square.<br>Ivory Scale, 6 inches long, per set, . . . . . | 13 00 |

No.	PRICE.
108. Same instruments as No. 107, in polished Walnut Box, per set,	\$14 00
109. Polished Walnut Box; pair of $5\frac{1}{2}$ inch Dividers, with Pen, Pencil and Needle Points, and Lengthening Bar. Pair of 5 inch plain Dividers. Pair of 3 inch Dividers, with Pen, Pencil, and Needle Points. Spring Bow Pen, with Needle Point. 2 Drawing Pens. German Silver Square. German Silver Protractor. Ivory Scale, 6 inches long, per set,	18 00
110. Polished Walnut Box; pair of $5\frac{1}{2}$ inch Dividers, with Pen, Pencil and Needle Points, and Lengthening Bar. Pair of 5 inch plain Dividers. Pair of 5 inch Hair Spring Dividers. Pair of 3 inch Dividers, with Pen, Pencil, and Needle Points. Spring Bow Pen, with Needle Point. 2 Drawing Pens. German Silver Square. German Silver Protractor. Ivory Scale, 6 inches long, per set,	20 00
111. Same instruments as No. 110, set in a tray, and the box much larger, with lock and key, thus affording space for extra instruments or colors, etc., per set,	23 00

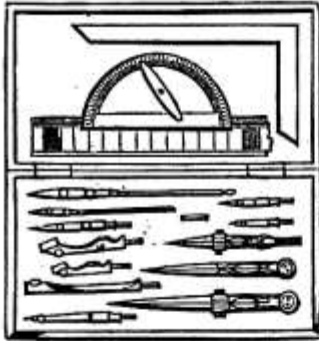

107

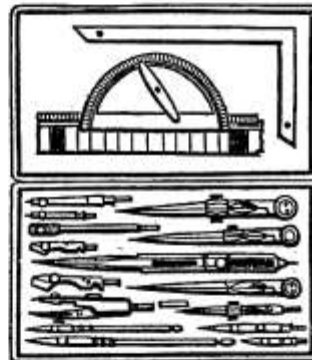

113

113. Polished Walnut Box, with lock and key, instruments set in a tray: pair of $5\frac{1}{2}$ inch Dividers, with Pen, Pencil and Needle Points, and Lengthening Bar. Pair of 5 inch plain Dividers. Pair of 5 inch Hair Spring Dividers. Pair of 3 inch Dividers, with Pen, Pencil, and Needle Points. Pair of $7\frac{1}{2}$ inch Proportional Dividers. Spring Bow Pen, with Needle Point. 2 Drawing Pens. German Silver Square. German Silver Protractor. Ivory Scale, 6 inches long, per set,	40 00
114. Polished Walnut Box; instruments same as No. 113, with addition of a Railroad or Double Drawing Pen, per set,	44 00
115. Polished Walnut Box, with lock and key, instruments set in a tray; pair of $5\frac{1}{2}$ inch Dividers, with Pen, Pencil and Needle Points, and Lengthening Bar. Pair of 5 inch plain Dividers. Pair of 5 inch Hair Spring Dividers.	

MATHEMATICAL INSTRUMENTS.

9

No.		PRICE.
	Pair of 3 inch Dividers, with Pen, Pencil, and Needle Points.	
	Pair of 7½ inch Proportional Dividers.	
	Spring Bow Pen, with Needle Point.	
	Two Drawing Pens. Double Drawing Pen.	
	Beam Compass Furniture. German Silver Square.	
	German Silver Protractor.	
	Ivory Scale, 6 inches long, per set,	\$56 00
116.	Polished Walnut Box, with lock and key, the instruments set in a tray; pair of 5½ inch Dividers, with Pen, Pencil and Needle Points, and Lengthening Bar, (the leg which holds the Needle Point has a hair spring movement).	
	5 inch plain Dividers. 5 inch Hair Spring Dividers.	
	3 inch plain Dividers.	
	3 inch Dividers, with Pen, Pencil, and Needle Points, (the leg which holds the Needle Point has a hair spring movement).	
	Spring Bow Pen, with Needle Point.	
	3 Drawing Pens. German Silver Square.	
	German Silver Protractor. Ivory Scale, 6 inches long.	
	All the pens have an extra thickness of steel for the screws to pass through, per set,	40 00
117.	Polished Rosewood Box, inlaid, lock and key, with tray, leaving space below for paints, rules, &c.; pair of 6½ inch Needle Point Dividers, with Pen, and Pencil Points and Lengthening Bar.	
	Pair of 4½ inch plain Dividers.	
	Pair of 4 inch Needle Point Dividers, with Pen and Pencil Points.	
	Pair of 7 inch Proportional Dividers. Spring Bow Pen.	
	3 Drawing Pens. Ivory Rule, 8 inches long.	
	Horn Protractor. Ivory Scale, 6 inches long.	
	1 Wood Curve and 2 Wood Squares, per set,	30 00
118.	Polished Rosewood Box, inlaid, with brass edges, lock and key, with tray, leaving space below for paints, rules, &c.; pair of 6 inch Needle Point Dividers, with Pen and Pencil Points, and Lengthening Bar.	
	Pair of 4½ inch plain Dividers, rounded points.	
	Pair of 4 inch Dividers, Needle Points, with Pen and Pencil Points.	
	Pair of 7½ inch Proportional Dividers.	
	Spring Bow Pen, Needle Point.	
	3 Drawing Pens.	
	Furniture for Beam Compass, with Micrometer Screw.	
	9 inch Horn Protractor.	
	Ivory Scale, 6 inches long.	
	Ivory Scale, 8 inches long, one edge divided to inches and eighths, the other to centimeters and millimeters, per set,	35 00

CASES OF SECOND QUALITY GERMAN SILVER INSTRUMENTS.

125.	Morocco Box; pair of 5½ inch Dividers, with Pen and Pencil Points.	
	Drawing Pen, per set,	2 25
126.	Morocco Box; pair of 5½ inch Dividers, with Pen and Pencil Points, and Lengthening Bar.	
	Pair of 5 inch plain Dividers.	
	Drawing Pen, per set,	3 25
127.	Morocco Box; pair of 5½ inch Dividers, with Pen, Pencil and Needle Points, and Lengthening Bar.	
	Pair of 5 inch plain Dividers.	
	2 Drawing Pens, per set,	4 75
128.	Morocco Box; pair of 5½ inch Dividers, with Pen, Pencil and Needle Points, and Lengthening Bar.	
	Pair of 5 inch plain Dividers.	
	Pair of 4 inch Dividers, with Pen, Pencil and Needle Points.	
	2 Drawing Pens, per set,	7 25

# SWISS DRAWING INSTRUMENTS,

OF GERMAN SILVER, EXTRA FINE FINISHED.

Having been for a long time Agents and Importers of these celebrated instruments, our experience and large stock enables us to give full satisfaction to parties wishing sets of them selected in parts and put up in handsome boxes for special purposes.

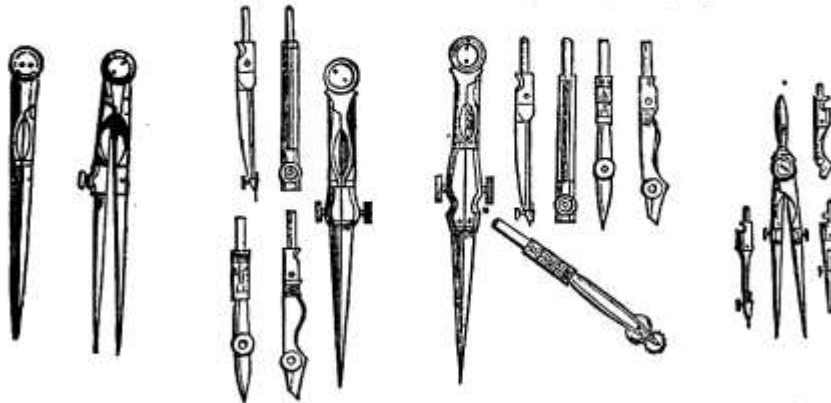

151	153	155	156	157	
151. Plain Dividers, $4\frac{1}{2}$ inches long, each,					\$2 00
152. " " 5 to 6 inches long, each,					2 25
153. Hair Spring Dividers, $4\frac{1}{2}$ inches long, each,					2 60
154. " " " 5 to 6 inches long, each,					3 25
155. Dividers, $6\frac{1}{2}$ inches long, with Pen, Pencil, Needle Points and Lengthening Bar, per set,					7 75
156. Dividers, $6\frac{1}{2}$ inches long, joints in each leg, with Pen, Pencil, Needle Points, Dotting Pen and Lengthening Bar, per set,					10 30
157. Dividers, 4 inches long, with Pen, Pencil and Needle Points, per set,					5 75

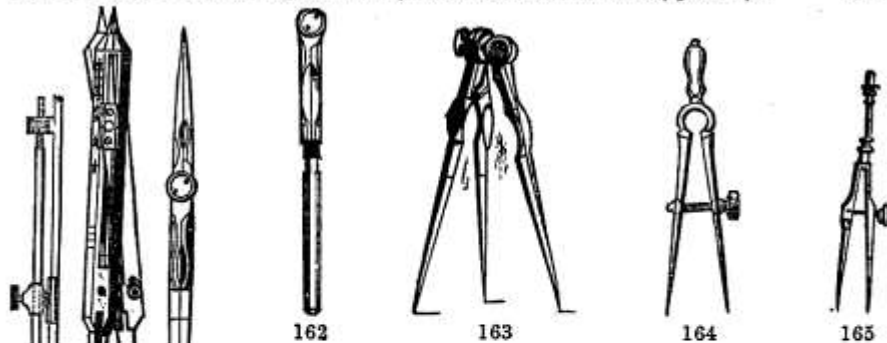

158. Proportional Dividers, finely graduated for lines and circles, 9 inches long,					12 00
159. Proportional Dividers, finely graduated for lines and circles, 9 inches long, with micrometer adjustment,					14 00
160. Proportional Dividers, graduated for lines, 8 inches long, with rack adjustment,					11 00
159. 161. Bisecting Dividers, $7\frac{1}{2}$ inches long, each,					4 00
162. Pocket Dividers, 5 to 6 inches long, with sheath, each,					2 50
163. Three-Legged Dividers, 5 to 6 inches long, each,					4 75
164. Steel-Spacing Dividers, 5 inches long, with Ivory Handle,					3 00
165. " " $3\frac{1}{2}$ " " " or Metal Handle,					1 75



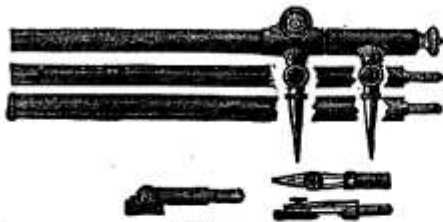

166



170

	PRICE.
166. Beam Compass, 20 inches long, in 2 bars, with Pen, Pencil, and two Straight Points, . . . . .	\$13 25
167. The same, 21 inches long, in 3 bars, . . . . .	15 00
168. " " 36 " " 4 " . . . . .	18 50
169. " " 54 " " 4 " . . . . .	22 00
170. Furniture for Wood Beam Compasses, in morocco box, . . . . .	8 50
170½. " " " " not in " " . . . . .	7 50

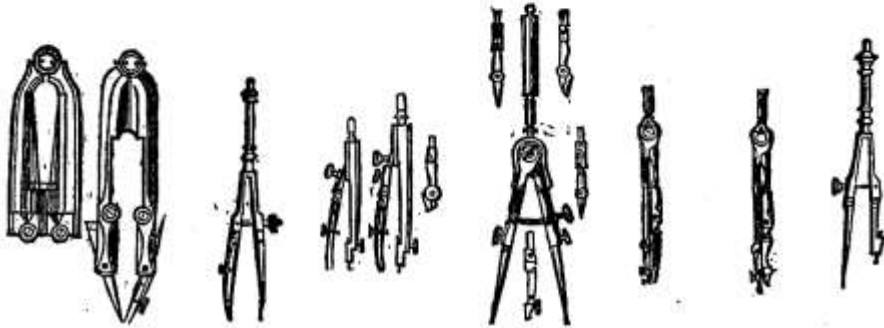

171. Pillar Compasses, or Pocket Set of Instruments, with Points to change, . . . . .	7 75
172. " " " " " " " " to turn, . . . . .	8 50
173. Spring Bow Pen, all steel, ivory handle, . . . . .	2 25
174. " " " German Silver, . . . . .	2 75
175. " " " " with Pencil Point, . . . . .	3 30
176. " " " 4 inches long, with Ivory Handle, Pencil, Needle, and two Pen Points, . . . . .	7 70
177. Simple Bow Pen, with Needle-Point, and joints in each leg, . . . . .	3 25
178. Simple Bow Pencil, " " " " " " . . . . .	3 25
179. Spring Bow Pencil, Ivory Handle, . . . . .	2 25



180. Drawing Pen, 4½ inches long, with joints, . . . . .	1 50
181. Drawing Pen, 5½ inches long, with joints, . . . . .	1 75
182. Drawing Pen, 6½ inches long, with joints, . . . . .	2 00
183. Railroad, or Double Drawing Pen, . . . . .	3 75
184. Railroad, or Double Drawing Pen, with joint in each side, . . . . .	3 75
185. Dotting Pen, . . . . .	2 60
186. Horn Centre, with German Silver edges, . . . . .	40
187. German Silver Centre, with Handle, . . . . .	50
188. German Silver Fastening Tacks, per dozen, . . . . .	85
189. Steel Fastening Tacks, per dozen, . . . . .	85

180 181 182 183 185 188

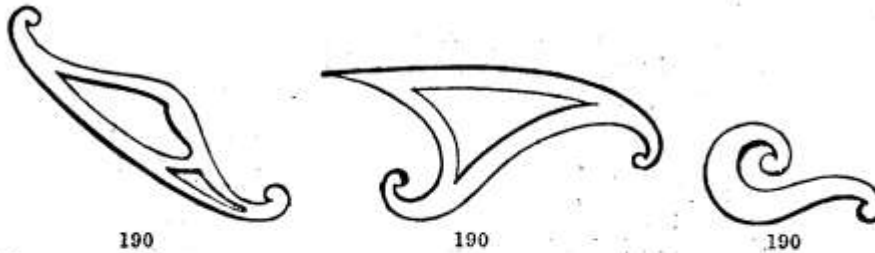

No.	PRICE.
190. Irregular Curves of Horn, each, . . . . .	\$1 00
191. Rolling Parallel Rule, ebony, . . . . .	3 30
192. Polar Planimeter, with printed instructions. . . . .	33 00

*For Boxwood and Ivory Scales, Protractors, &c., &c., see pages 16 and 17.*

Parties wanting cases made up of these Instruments, can select the pieces, by the above list, that are best adapted to their purpose, and we will have boxes made to suit, at an additional cost of from \$7 to \$15, according to the size of the boxes, which are made of rosewood, mahogany or walnut, highly finished.

#### CASES OF EXTRA FINE SWISS DRAWING INSTRUMENTS.

- |   |       |
|---|-------|
| 200. Polished Walnut Box, with lock and key, and tray. Containing:<br>Pair Dividers, $6\frac{1}{2}$ inches long, with Pen, Pencil, and Needle Points, and Lengthening Bar.<br>Pair plain Dividers, $5\frac{1}{2}$ inches long.<br>Steel Bow Pen, with spring.<br>Two Drawing Pens, (one $4\frac{1}{2}$ inches long, and one $6\frac{1}{2}$ inches long.)<br>Half circle Protractor, 5 inches diameter, $\frac{1}{2}$ degrees.<br>Triangular Scale of boxwood, 12 inches long, per set, . . . . .  | 25 00 |
| 201. Same as No. 200, with the addition of a pair of Dividers, $3\frac{1}{2}$ inches long, with Pen, Pencil, and Needle Points, and a Steel Bow Pencil, with spring, per set, . . . . .   | 33 00 |
| 202. Polished Rosewood Box, with lock and key, and tray. Containing:<br>Pair Dividers, $6\frac{1}{2}$ inches long, with Pen, Pencil, and Needle Points, and Lengthening Bar.<br>Pair Dividers, $3\frac{1}{2}$ inches long, with Pen, Pencil, and Needle Points.<br>Pair plain Dividers, $5\frac{1}{2}$ inches long.<br>" Hair Spring Dividers, $5\frac{1}{2}$ inches long.<br>" Steel Spacing Dividers, $3\frac{1}{2}$ inches long, with spring.<br>Steel Bow Pen, with spring.<br>" Pencil, "<br>Three Drawing Pens, (one $4\frac{1}{2}$ inches, one $5\frac{1}{2}$ inches, and one 6 inches long.)<br>Half circle Protractor, $6\frac{1}{2}$ inches diameter, $\frac{1}{2}$ degrees.<br>Triangular Scale of boxwood, 12 inches long, per set, . . . . . | 45 00 |
| 203. Same as No. 202, with the addition of a pair of Proportional Dividers 9 inches long, and the Protractor graduated in $\frac{1}{2}$ degrees, per set, . . . . .   | 60 00 |
| 204. Polished Rosewood Box, with lock and key, and tray. Containing:<br>Pair Dividers, $6\frac{1}{2}$ inches long, with Pen, Pencil and Needle Points, and Lengthening Bar.<br>Pair Dividers, 3 inches long, with Pen, Pencil, and Needle Points.<br>" plain Dividers, $5\frac{1}{2}$ inches long.<br>" Hair Spring Dividers, $5\frac{1}{2}$ inches long.<br>" Proportional Dividers, 9 inches long.<br>" Steel spacing Dividers, $3\frac{1}{2}$ inches long, with spring.<br>Steel Bow Pen, with spring.<br>" Pencil, "  |       |





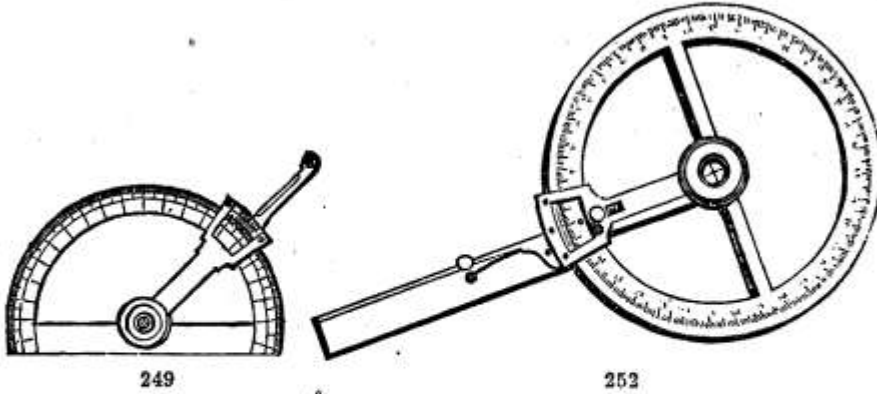

No.	PRIOR.
249. Protractor, 5½ inches diameter, ½ circle, ½ degrees, with vernier reading to three minutes,	\$11 25
250. Protractor, 8 inches diameter, ½ circle, ½ degrees, with vernier reading to one minute,	14 50
251. Protractor, 10 inches diameter, ½ circle, ½ degrees, with vernier reading to one minute,	18 25
252. Protractor, 5½ inches diameter, whole circle, ½ degrees, with vernier reading to three minutes,	14 00
253. Protractor, 8 inches diameter, whole circle, ½ degrees, with vernier reading to one minute,	16 25

**IVORY SCALES AND PROTRACTORS.**



255. Ivory Sector, 6 inches—opens to 12 inches,	2 25
256. Ivory Scale, 6 inches long, same as in School Cases of Instruments,	80
257. " Chain Scales, 12 inches long, graduated on two edges with either 10 and 10 parts, or 10 and 20, or 20 and 40, or 30 and 50, or 40 and 60, or 50 and 60, each,	3 50
258. " " " " with 40 and 80, or 50 and 100, each,	6 00
259. " " " " with 80 and 100, each,	8 75
260. Ivory Architects Scales, 12 inches long, each,	3 50
261. " " " " with diagonal scale on one side, each,	3 50
262. " " " " with 16 different graduations all brought to the edges, each,	3 50
264. Ivory Protractor, 6 inches long, 1¾ inches wide, whole degrees, with 6 scales of equal parts, 4 scales of feet and inches, 2 scales of chords and diagonal scale,	1 50
265. Ivory Protractor, 6 inches long, 1¾ inches wide, whole degrees, with 6 scales of equal parts, 8 scales of feet and inches, 2 scales of chords and diagonal scale,	2 50
266. Ivory Protractor, 6 inches long, 2 inches wide, whole degrees, with 8 scales of equal parts, 10 scales of feet and inches, 2 scales of chords, diagonal scale and line of 40 on lower edge,	3 50
267. Ivory Protractor, same as No. 266, but in ½ degrees,	4 50
268. " 6 inches long, 2¼ inches wide, ½ degrees, with 10 scales of equal parts, 12 scales of feet and inches, 2 scales of chords, diagonal scale, and line of 40 on lower edge,	5 75

No.	PRICE.
269. Ivory Protractor, 6 inches long, $2\frac{1}{2}$ inches wide, with 8 scales of equal parts, 12 scales of feet and inches, 3 scales of chords, lines of sines, tangents, secants, hours, &c., &c., and line of 40 on lower edge,	\$7 75
270. Ivory Protractor, 8 inches long, 2 inches wide, $\frac{1}{2}$ degrees, with 6 scales of equal parts, 8 scales of feet and inches, 2 scales of chords, diagonal scale and line of 40 on lower edge,	5 75
271. Ivory Protractor, 12 inches long, $2\frac{1}{2}$ inches wide, $\frac{1}{2}$ degrees, with 10 scales of equal parts, 12 scales of feet and inches, 2 scales of chords, diagonal scale and line of 40 on lower edge,	14 00

### BOXWOOD PROTRACTORS AND SCALES.

272. Boxwood Protractor, 6 inches long, $1\frac{3}{4}$ inches wide, whole degrees, with 6 scales of equal parts, 4 scales of feet and inches, 2 scales of chords, and diagonal scale,	75
273. Boxwood Scale, 6 inches long, same as in School Cases of Instruments,	30
274. " " 12 " " for Architects,	1 25
275. " " 12 " " with 16 different graduations, all brought to the edges,	1 25
276. Boxwood Scale, 12 inches long, for Architects, with diagonal scale on one side,	1 25



277

277. Triangular Scale of Boxwood, 24 inches long, graduated 10, 20, 30, 40, 50 and 60 to the inch; or, 20, 30, 40, 50, 60, and 80, for engineers,	5 00
278. " " " " " " 12 inch,	2 00
279. " " " " " " 6 " "	1 50
280. Triangular Scale of Boxwood, 24 inches long, graduated $\frac{3}{32}$ , $\frac{1}{8}$ , $\frac{1}{4}$ , $\frac{1}{2}$ , $\frac{3}{8}$ , $\frac{1}{2}$ , $\frac{3}{4}$ , 1, $1\frac{1}{2}$ , 3 inches and 16ths to the foot, for architects,	5 00
281. " " " " " " 12 inches long,	2 00
282. " " " " " " 6 " "	1 50
283. Boxwood Gunter Scales, 12 inches long,	65
284. Satin Wood " " 24 " "	1 00

### PAPER SCALES.

285. Paper Scale, printed on card-paper, $1\frac{1}{2}$ inch wide, 12 inches long; graduations on one edge inches and 10ths, and the other feet and 100ths,	10
286. Paper Scale, same as 285, one edge 20 parts to the inch, the other edge 40,	10
287. Paper Scale, same as 285, one edge, inches and sixteenths; the other edge inches and forty-eighths,	10
288. Paper Scales, printed on card-paper, 19 inches long, for architects and engineers, in sets of 6 scales, per set, Series A contains 6 scales, one each, divided to $\frac{1}{4}$ , $\frac{1}{2}$ , $\frac{3}{4}$ , 1, $1\frac{1}{2}$ and 3 inches to the foot, for architects. Series B contains 6 scales, one each, divided to $\frac{3}{32}$ , $\frac{1}{8}$ , $\frac{1}{4}$ , $\frac{1}{2}$ , $\frac{3}{4}$ , and $\frac{1}{2}$ inch to the foot, for architects. Series C contains 6 scales, one each, divided to 10, 20, 30, 40, 50 and 60 parts to the inch, for engineers.	1 00
289. Single Scale of any of the above series, A, B, C—each scale,	20
290. Paper Scales, same as 288, divided either to $\frac{1}{8}$ , $1\frac{1}{8}$ , $1\frac{1}{4}$ or $1\frac{3}{8}$ inches to the foot, each,	20

The advantages of these scales are—they expand and contract nearly the same as drawing-paper, do not soil the work, and distances can be set off from them without the use of dividers

**STEEL RULES FOR MACHINISTS.**

No.		PRICE.
291.	24 inch steel rule, divided to 8ths, 10ths, 12ths, 14ths, 16ths, 20ths, 24ths, 28ths, 32ds, 48ths, 50ths, 64ths, and 100ths of an inch,	\$4 00
292.	12 inches, " " " " " "	2 00
293.	9 " " " " " "	1 50
294.	6 " " " " " "	1 00
295.	4 " " " " " "	75
296.	3 " " " " " "	50

**AMES' PATENT UNIVERSAL SQUARE.**

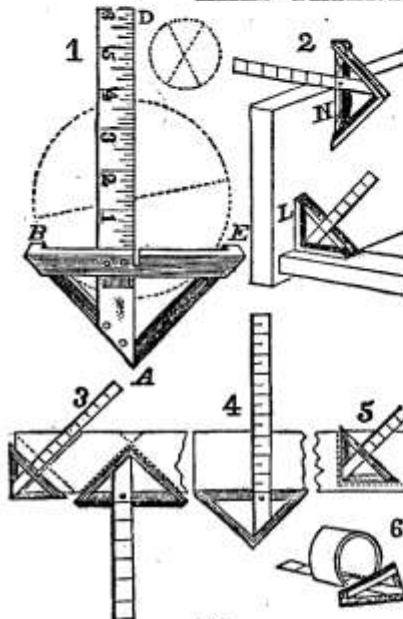

This square combines, in a most convenient form, *five different instruments*, viz., The TRY-SQUARE, the MITER, the T-SQUARE, the GRADUATED RULE, and (what is entirely new) the CENTRE-SQUARE, for finding the centre of a circle.

Fig. 1 explains its application as a CENTRE-SQUARE. Put the instrument over the circle, as the end of the bolt or shaft, with the arms B A, A H resting against the circumference, in which position one edge of the rule, A D, will cross the centre. Mark a straight line in this position; apply the instrument again to another part of the circumference, and mark another line crossing the first. The point where the two lines cross each other will be the centre of the circle. The whole is the work of a moment. Fig. 2 explains the application of the instrument as a carpenter's TRY-SQUARE, H, and an OUTSIDE-SQUARE, L; Fig. 3, as a MITER; Fig. 4, as a T-SQUARE and a GRADUATED RULE; Figs. 5 and 6 as an OUTSIDE-SQUARE for drawing, and a T-SQUARE for machinists.

The tongue D A, (Fig. 1,) being fastened, as it is, into the triangular frame B A H, cannot be moved or knocked from its place,—in this respect constituting a great improvement over the carpenter's Try-Square, T-Square, and Miter in common use. The instruments are made of the best material, neatly finished, and perfectly true.

"As a CENTRE-SQUARE alone, it is invaluable to every mechanic. . . . In short, it combines, in a most convenient form, so many useful instruments, no mechanic's list of tools can well be complete without a Universal Square."—*Scientific American*, Sept. 22, 1855.

297

297.	Ames' Patent Universal Square, Blade 6 inches long,	3 50
298.	" " " " 8 " "	4 00
299.	" " " " 10 " "	4 50
300.	" " " " 12 " "	5 00

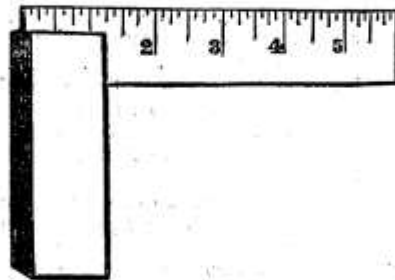

301

301.	Steel Square for Machinists, divided to 32ds of an inch, blade 3 in. long,	2 50
302.	" " " " " " " 4 " "	3 00
303.	" " " " " " " 6 " "	3 50
304.	" " " " " " " 9 " "	4 00
305.	" " " " " " " 12 " "	6 00



## TRIANGLES, SQUARES, CURVES, &amp;c., &amp;c.

No.		PRICE.
306.	Steel Straight Edge, 48 inches long,	\$10 00
307.	" " " 36 "	7 50
308.	" " " 30 "	5 00
309.	" " " 24 "	3 50
310.	Whitewood Straight Edges, 20 inches long,	25
311.	" " " 30 "	45
312.	" " " 40 "	75
313.	" " " 50 "	85
314.	" " " 60 "	1 75



315

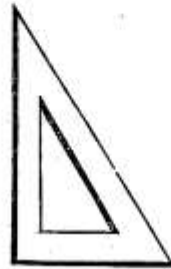

319



329



330

315.	Whitewood Triangles, 30, 60, and 90 degrees, perpendicular, 5 to 7 inches long, each,	25
316.	" " " 30, 60, and 90 degrees, perpendicular, 7 to 10 inches long, each,	35
317.	" " " 30, 60, and 90 degrees, perpendicular, 12 inches long, each,	45
318.	" " " 45, 45 and 90 degrees, perpendicular, 3 to 6 inches long, each,	25
319.	" " " 30, 60, 90, framed, with open centre, perpendicular, 6 to 10 inches long, each,	75
320.	" " " framed, with open centre, perpendicular, 12 to 15 inches long,	1 25
321.	" " " framed, with open centre, perpendicular, 20 inches long, each,	2 00
322.	" " " 45, 45 and 90 degrees, framed, with open centre, perpendicular, 4 to 7 inches long, each,	50
323.	" " " 45, 45 and 90 degrees, framed, with open centre, perpendicular, 8 to 11 inches long, each,	1 00
324.	" " " 45, 45 and 90 degrees, framed with open centre, perpendicular, 12 to 15 inches long, each,	1 75
325.	German Silver Triangle, 30, 60, and 90 degrees, perpendicular, 6 to 7 in.	2 50
326.	" " " " " " " 9 to 10 "	4 00
327.	" " " 45, 45 and 90 " " " 4 to 5 "	2 25
328.	" " " " " " " 6 to 7 "	4 00
329.	" Squares, perpendicular, 6 to 7 "	1 10
330.	Whitewood Irregular Curves, 5 to 9 inches long, various patterns, each,	50
331.	" " " 10 to 12 " " " " "	75
332.	" " " 13 to 18 " " " " "	1 10
332½.	Drawing Board, 15 inches wide, by 21 inches long,	2 50



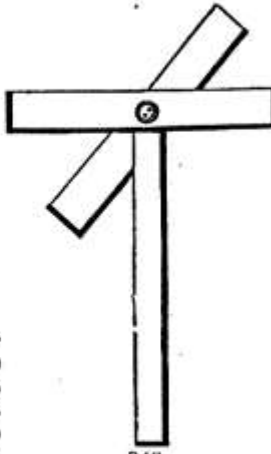
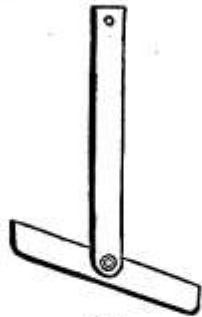
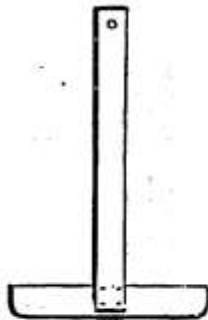

No.	333	338	PRICE.
333.	T Square, fixed head, blade 15 inches long, each,		\$0 50
334.	" " " " 20 " " "		75
335.	" " " " 30 " " "		85
336.	" " " " 40 " " "		1 00
337.	" " " " 50 " " "		1 75
339.	" single head to turn, blade 20 inches long, each,		\$1 25
339.	" " " " 30 " " "		1 50
340.	" " " " 40 " " "		1 75
341.	" " " " 50 " " "		2 00
342.	" double " " 24 " " "		1 75
343.	" " " " 30 " " "		2 00
344.	" " " " 42 " " "		2 75
345.	" " " " 24 " " brass edges,		2 50
346.	" " " " 30 " " "		3 00
347.	" " " " 42 " " "		4 00

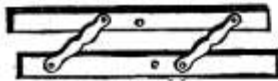

348



355

348.	Parallel Rulers, ebony, brass mounted, 6 inches long, each,	35
349.	" " " " 9 " " "	75
350.	" " " " 12 " " "	1 00
351.	" " " " 15 " " "	1 25
352.	" " " " 18 " " "	1 50
353.	" " " " 24 " " "	3 00
354.	" " " German Silver mounted, 12 inches long, each,	1 75
355.	" " all German Silver, on rollers, 15 " " "	10 00
356.	" " " " 18 " " "	12 00
357.	" " all Brass, on rollers, 9 inches long,	6 00
358.	" " " " 12 " " "	8 75
359.	" " " " 15 " " "	10 00
360.	" " ebony, " 12 " " "	3 75
361.	" " " " 15 " " "	4 50
362.	" " " " 18 " " "	5 50
363.	" " ivory, graduated edges, on rollers, 12 inches long,	6 00
364.	" " " " 15 " " "	7 50
365.	" " " " 18 " " "	9 50
366.	Engineer's Tacks, thick heads, Brass, per doz.	30
367.	" " thin " " "	40
368.	" " " " small size,	50 & 75
369.	Engineer's Tacks, thin heads, large size, German Silver, very fine, per doz.,	1 50
370.	Right-angled Tacks of Brass, with three points for corners, per doz.,	75
371.	Horn Centre, for preventing the Dividers making holes in the paper, each,	25



367



370



371

## SURVEYOR'S COMPASSES, &amp;c.

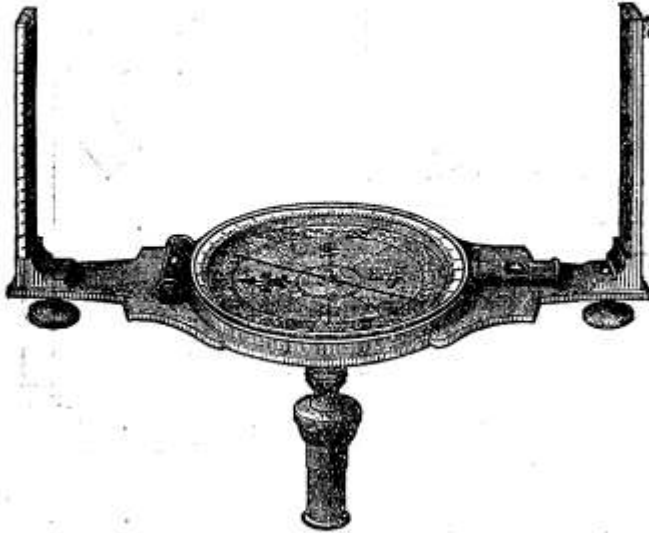

372

No.		PRICE.
372.	Surveying Compass; 4 inch Needle, 12½ inch Plate, two straight Levels, Jacob Staff mountings, .	\$30 00
373.	Surveying Compass; 5 inch Needle, 15½ inch Plate, two straight Levels, Outkeeper and Jacob Staff mountings, .	38 00
374.	Surveying Compass; 6 inch Needle, 15½ inch Plate, two straight Levels, Outkeeper and Jacob Staff mountings, .	42 00

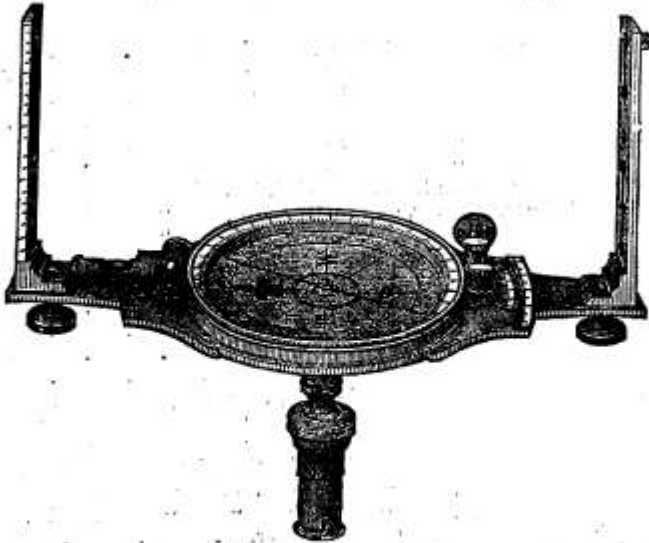

375

375.	Surveying Compass; 6 inch Needle, 15½ inch Plate, two straight Levels, Outkeeper and Nonius, and Jacob Staff mountings, .	53 00
------	---	-------

**THE RAILROAD COMPASS.**

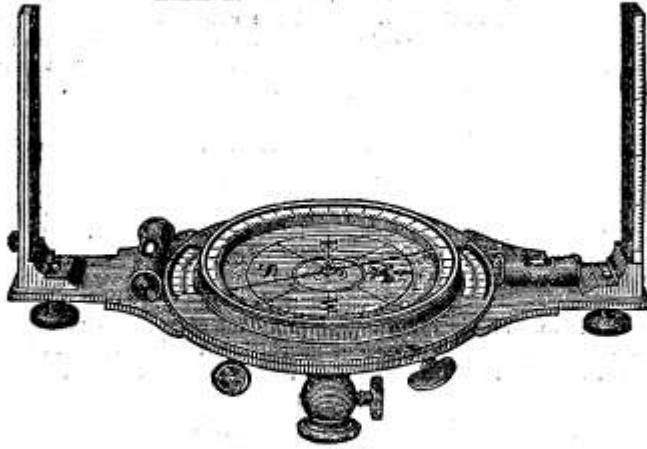

No.

376

376. The Railroad Compass, here represented, has the main plate, levels, sights, and needle of the ordinary instrument, but is also provided with a circle on the outside of the compass-box, divided all around, and reading by two opposite Verniers to single minutes of a degree. The divisions are all under glass, and thus completely protected from dust and moisture. The Verniers are fixed to the main plate, having a long socket, which gives it great stability and a motion round the circle

**VERNIER TRANSIT COMPASS.**



377

No.

PRICE.

almost perfectly free from friction. The movement of the Vernier plate, with the sights attached, around the compass circle, gives the surveyor the power of laying off the variation of the needle, while the graduated circle enables him to take horizontal angles with great accuracy and minuteness, entirely independent of the needle, . . . \$83 00

**VERNIER TRANSIT.**

377. The Vernier Transit, or Transit Compass, has the same general properties as the Vernier Compass, but is furnished with a Telescope in place of the ordinary sights. The Telescope is from ten to twelve inches long, and sufficiently powerful to see and set a flag at a distance of two miles, in a clear day. With light Tripod, . . . 90 00
378. To the Vernier Transit a vertical circle, with clamp and tangent screw, (as seen in No. 377,) is often attached to the axis of the Telescope, giving, with a Vernier, the means of measuring vertical angles to five minutes of a degree. With Tripod, . . . 108 00

**ENGINEER'S AND SURVEYOR'S TRANSIT.**

379

379. This instrument is, in principle, very similar to the Railroad Compass, differing from it mainly in the substitution of the Telescope, with its appendages, for the ordinary sight. The needle of this instrument is  $5\frac{1}{2}$  inches long: it has a limb of 7 inches diameter, and weighs, with the Tropic head attached, from twelve to thirteen pounds. The Telescope is the same as that used on the Vernier Transit. The instrument is accompanied with an adjusting Tripod head, as represented in the figure, . . . 165 00

379½.	Same as No. 379, but with only one Vernier to the limb,	. \$145 00
380.	Same as No. 379, with the addition of a Level under Telescope, with ground bubble and scale, and with clamp and Tangent movement, as shown in the cut.	. 188 00
380½.	Same as No. 380, but with one Vernier to the limb,	. 168 00
381.	Same as No. 380, with Vertical Circle and Vernier Reading to minutes,	. 200 00
381½.	Same as No. 381, but with one Vernier to the limb,	. 180 00

**ENGINEER'S LEVEL.**

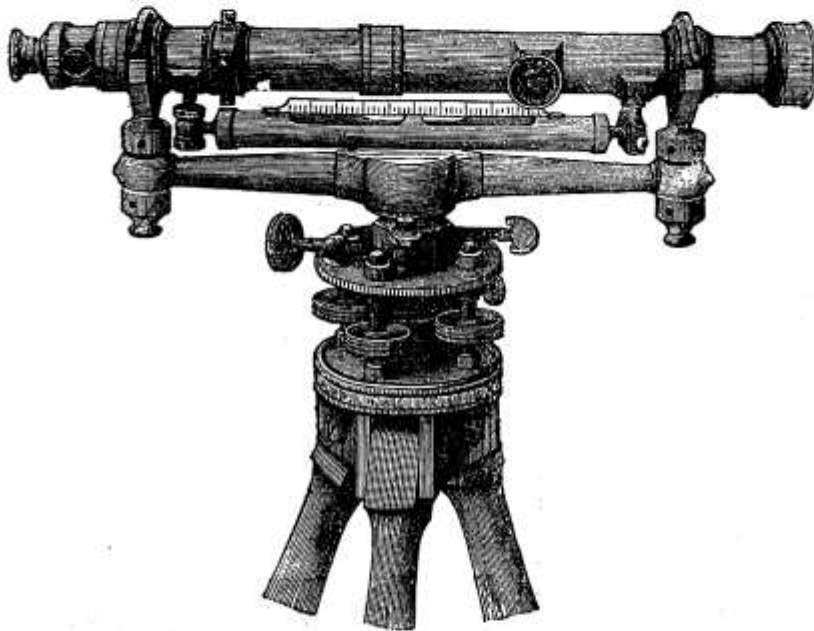

382

382.	An eighteen-inch Y Level, of the most approved form and construction. In this instrument the Telescope is made to revolve readily and truly in the Ys by rings of bell-metal, which, when desired, may be firmly clamped by the clips, and held in any position. It has a rack-and-pinion movement to both object and eye glasses, an adjustment for centering the eyepiece, and another for insuring the accurate projection of the object glass in a straight line. Both of these are completely concealed from observation and disturbance by a thin ring, which slides over them. The Ys of this level are made large and strong, of the best bell-metal, and each have two nuts, both being adjustable with the ordinary steel pin. The level bar is made round, of well-hammered brass, and shaped so as to possess the greatest strength in the parts most subject to sudden strains. The Tripod head has the same plates and levelling screws as that of the Engineer's Transit,	. 135 00
383.	Builders' level, with twelve-inch Telescope,	. 50 00
383½.	“ “ “ “ “ and Parallel plates, with four levelling screws,	. 60 00

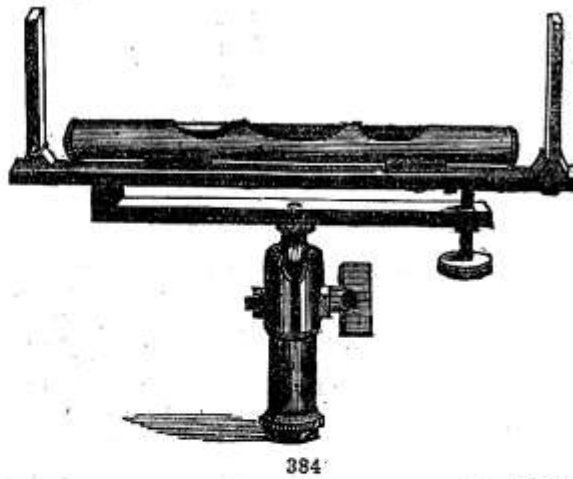
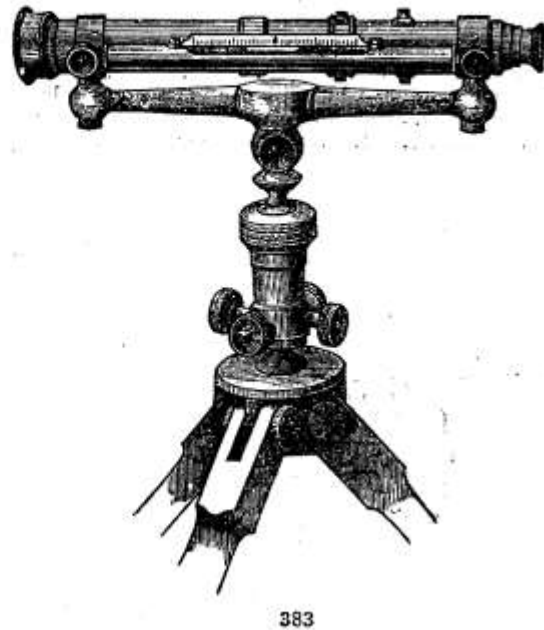
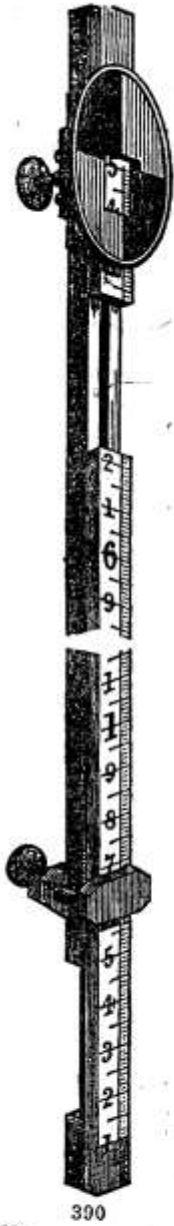

No.

384. Level, brass mounted; plate 12 inches long, with sights and ball-and-socket joint,

PRICE.

\$20 00

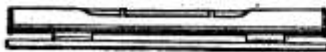

385

385. Levels, mounted in brass, for mechanical purposes; 3 to 12 inches long, per inch,

25

387. Level Bulbs, unmounted, 2 to 6 inches long, each

12 to 50

MATHEMATICAL INSTRUMENTS.

25

No.	PRICE.
388. Plumb Bobs, brass, accurate; steel points, screw caps, each, . . . . .	\$2 25
389. Marking Pins, steel, a set of 11, . . . . .	1 50
390. Levelling Rod, made of satin-wood, with improved clamp and target, machine divided to tenths and hundredths of a foot, slides out to 12 feet, . . . . .	16 00
391. Compass Tripod, . . . . .	8 00
392. " " with levelling screws and clamp, and tangent movement, . . . . .	18 00
393. Compound Ball, with tangent movement; can be used with Jacob staff or Compass Tripod, . . . . .	8 00

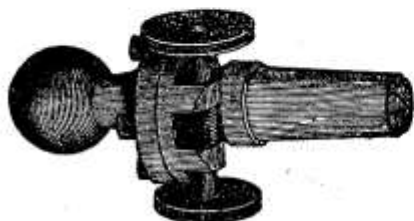

393



394

394. New Hand Level, for Engineers, . . . . .	9 00
395. Locke's Hand Level, made of German Silver, . . . . .	12 00
396. " " " brass, . . . . .	10 00



395

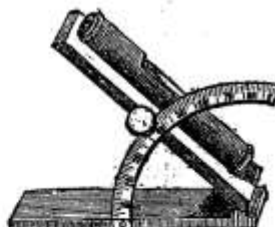

398

397. Clynometer, or Slope Level, with sights, and ball, and socket, packed in morocco box, . . . . .	18 00
398. Clynometer, or Slope Level, small size, packed in morocco box, . . . . .	8 50
399. Same as 398, larger size, . . . . .	12 00
400. Odometer, for measuring distances, to be attached to the wheel of a carriage, made with accuracy, . . . . .	20 00

SURVEYOR'S AND ENGINEER'S CHAINS.

401. Surveyors' Chain, 2 poles, 50 links, No. 9, wire oval rings, . . . . .	2 00
402. " " 2 " 40 " 8, " " . . . . .	2 50
403. " " 2 " 50 " 8, " oval rings, . . . . .	2 50
404. " " 2 " 50 " 7, " " . . . . .	3 25
405. " " 4 " 100 " 9, " round rings, . . . . .	4 00
406. " " 4 " 100 " 8, " oval rings, . . . . .	5 00
407. " " 4 " 100 " 7, " " . . . . .	6 00

No.					PRICE.
408.	Surveyors' Chain,	4 poles,	100 links,	No. 12, best steel wire, brazed links and rings,	\$14 00
409.	"	"	2 " 50 "	12, best steel wire, brazed links and rings,	7 00
410.	Engineers'	"	50 feet, 50 links,	No. 7 wire,	4 00
411.	"	"	100 " 100 "	7 " "	6 50
412.	"	"	50 " 50 "	12, best steel wire, brazed links and rings,	8 00
413.	"	"	100 " 100 "	12, best steel wire, brazed links and rings,	15 00

## TAPE MEASURES.



414

414.	Best London Tape Measure,	in strong leather case,	50 feet long,	in 10ths or 12ths, each,	2 50
415.	"	"	"	100 feet long, in 10ths or 12ths,	3 50

Metallic Tape Measures, leather cases; a new article, the most durable for Engineers and Surveyors; made of linen thread interwoven with fine brass wire, not so liable to stretch as the usual linen tape, and better calculated to withstand the effect of moisture.

416.	Metallic Tape Measure,	33 feet long,	in 10ths or 12ths, each,	3 25
417.	"	"	50 " " " "	4 25
418.	"	"	66 " " " "	4 75
419.	"	"	70 " " " "	5 25
420.	"	"	80 " " " "	6 00
421.	"	"	100 " " " "	6 75

Steel Tape Measures; all steel, to wind up in a box, same as linen measure, the most accurate, durable, and portable measure.

422.	Steel Tape Measure,	33 feet long,	in 10ths or 12ths, each,	9 00	
423.	"	"	50 " " " "	12 50	
424.	"	"	66 " " " "	15 50	
425.	"	"	100 " " " "	22 50	
426.	Pocket Tape Measure,	all steel, in German Silver cases,	with spring and stop,	6 feet, 10ths or 12ths, each,	3 75
427.	"	"	"	3 feet, 10ths or 12ths,	2 00
428.	Pocket Tape Measures,	linen, in silver plated cases,	with spring and stop,	5 feet, each,	1 00
429.	"	"	"	3 feet,	75



POCKET RULES.

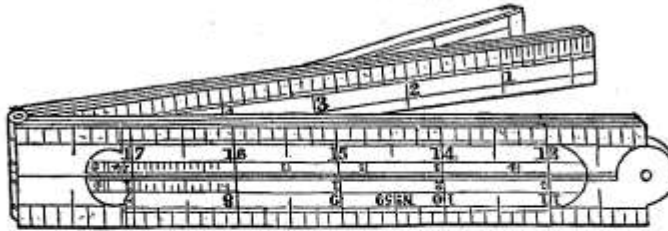

No.	430	PRICE.
430.	One Foot, 4 Fold; boxwood, each.	\$0 35
431.	“ “ “ brass edges.	1 00
432.	“ “ ivory, brass mounted.	1 00
433.	“ “ “ German Silver mounted,	1 50
434.	“ “ “ “ “ graduated in 10ths and 100ths, for engineers.	2 25
435.	“ “ “ “ “ edges.	2 75
436.	Two Feet, 4 Fold; boxwood.	50
437.	“ “ “ brass edges.	1 50
438.	“ “ ivory, German Silver bound, with 8th, 10th and 16th inches, and $\frac{1}{4}$ , $\frac{1}{2}$ , $\frac{3}{4}$ and 1 inch drafting scales,	6 50
439.	“ “ “ German Silver edges,	7 50
440.	Two Feet, 6 Fold Rules, boxwood, graduated 8th, 10th, 10th and 16th in.,	1 25
441.	“ “ “ ivory, “ “ “	6 50
441 $\frac{1}{2}$ .	Gear or Cog Wheel Rules, for calculating the number of cogs to be cut, of any desired size, in a certain diameter. Made of boxwood; two feet long, two-fold, brass bound; graduated from 5ths to 16th of inches; with descriptive table. Each,	\$4 00

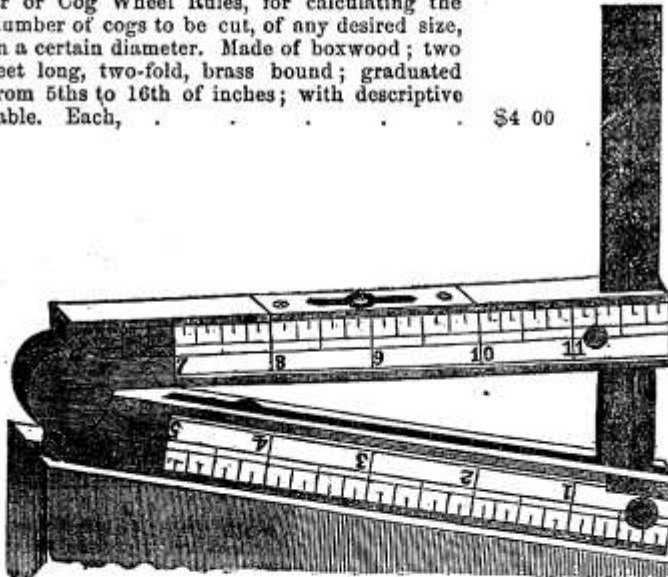

442		
442.	Combination Rule, 1 Foot, 2 Fold, boxwood. This the most convenient and useful pocket-rule ever made; it combines in itself a Carpenter's Rule, Spirit Level, Square, Plumb, Bevel, Indicator, Brace, Scale, Draughting Scale of equal parts, T Square, Protractor, Right angle Tri- angle, and with a straight edge can be used as a Parallel Ruler, all the parts of which, in their separate applications, are perfectly reliable,	3 50
443.	Combination Rule, 1 Foot, 2-Fold; ivory, same as above,	8 50
An explanation and directions for use accompanies each of the Combination Rules.		
444.	Two Feet, 2 Fold, boxwood slide rule, Routledge's, with book,	2 00
445.	Kentish Slide Rule,	10 00

## POCKET COMPASSES.



446



448

No.	Price.
446. Compasses of brass; $2\frac{1}{2}$ inches diameter, with sights and ball and socket joints, in morocco cases, each, . . . . .	\$12 00
447. " " " " " " $3\frac{1}{2}$ inches diameter, . . . . .	14 00
448. Miner's Compass, for tracing iron ore, . . . . .	12 00

This consists essentially of a dipping needle, about  $2\frac{1}{2}$  inches long, which inclines towards any mass of iron, and thus discovers its position.

When used for tracing ore, the observer should hold the ring in his hand, and keep the needle north and south, standing with his face to the west.

If held horizontal, it serves, of course, as an ordinary pocket compass.



449



451

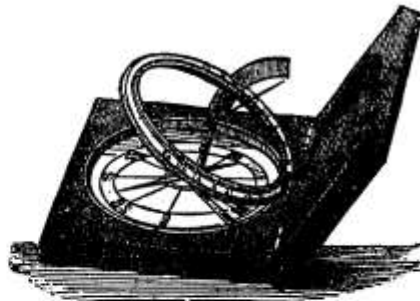

452

449. Prismatic Azimuth Compass of Brass, 3 inches diameter, . . . . .	20 00
450. " " " " $4\frac{1}{2}$ " " " " . . . . .	25 00
451. Geological Compass of Brass, with pendulum for ascertaining the angle of dip in rocks, each, . . . . .	6 00
452. Pocket Compass, mahogany case, with universal sun dial, each, . . . . .	10 50
453. " " brass, with levels and leveling screws and universal sun dial, each, . . . . .	17 00
454. " " brass, with hinged cover and sun dial, 2 inch diameter, . . . . .	6 00
455. " " " " " " $2\frac{1}{2}$ " " " " . . . . .	7 00



No.	458	465	470	Price.
456.	Pocket Compass, round red wood case, no stop to needle, each, .			\$0 25
457.	" " square " " " "			40
458.	" " mahogany case, 1½ in. square, with stop to needle, each,			1 75
459.	" " " " 2 " " " " "			2 00
460.	" " " " 2½ " " " " "			2 50
461.	" " " " 3 " " " " "			3 00
462.	" " brass round, with cover, 1½ inches diameter, no stop to needle,			50
463.	" " brass round, with cover, 1½ inches diameter, with stop to needle,			1 50
464.	" " brass round, with cover, 1½ inches diameter, with stop and agate centre to needle,			2 25
465.	" " watch pattern, brass, 1 in. diameter, no stop to needle,			75
466.	" " " " 1½ " " " " "			1 00
467.	" " " " 1 " " with " "			1 00
468.	" " " " 1½ " " " " "			1 50
469.	" " " " 1½ " " " and agate centre to needle,			1 50
470.	" " watch pattern, brass, 2 in. diameter, with stop and agate centre to needle,			2 25
471.	" " watch pattern, brass, 1½ inches diameter, with hinged cover and stop to needle,			2 25
472.	" " watch pattern, brass, 1½ inches diameter, with hinged cover, stop and agate centre to needle,			3 00
473.	" " watch pattern, German Silver, 1½ inches diameter, hinged cover, stop and agate centre to needle,			4 25
474.	Pocket Compasses; gilt, watch pattern, with stop, enamelled dial and agate centre; 1 to 2 inches diameter, in morocco cases, (a very superior London article, such as are used by officers in the British army,) 1½ inches diameter, each, .			9 50
475.	" " " " 1½ inches diameter.			10 50
479.	Boat Compass, 3 inches diameter, brass case with floating card, each, .			2 25
480.	Charm Compasses, gilt, to hang to watch guard, each, .			25
481.	" " solid gold, to hang to watch guard, each, .			3 00

**ENGINEER'S STATIONERY, &c.**

In filling orders for Instruments from different parts of the country, we have frequently been called upon to furnish in addition, the various materials for the office work of the Surveyor and Engineer, as Drawing Paper, Colors, Text Books, &c. We have therefore supplied ourselves with an assortment of these goods, and shall hereafter be able to furnish them on as favorable terms as any other dealers in the Union.

**WHATMAN'S TURKEY MILL DRAWING PAPERS.**

482. Demy,	20x15 inches, per sheet,	.09;	per quire,	1 50
483. Medium,	22x17 " "	.12;	" "	2 00
484. Royal,	24x19 " "	.15;	" "	3 00
485. Super-Royal,	27x19 " "	.18;	" "	3 50
486. Imperial,	30x21 " "	.25;	" "	5 50
489. Atlas,	33x26 " "	.30;	" "	6 00
490. Double Elephant,	40x26 " "	.40;	" "	8 00
491. Antiquarian,	52x31 " "	2.00;	" "	35 00

No.		PRICE.
402.	<b>ROLL DRAWING PAPER, EXTRA WHITE.</b>	
	Best German make, 40 inches wide, weight 8 ounces to the yard, per yard,	\$0 40
	“ “ 40 “ “ 5 “ “ “ “	30
	“ “ 54 “ “ 11 ounces, “ “	50
	“ “ 54 “ “ 8 “ “ “	40
493.	<b>MUSLIN BACKED ROLL DRAWING PAPER, EXTRA WHITE.</b>	
	Best German make, 40 in. wide, in 20 yard rolls, per roll, \$22 00, per yard,	1 50
	“ “ 54 “ “ “ “ 30 00, “	2 00
494.	<b>ROLL DRAWING PAPER, BUFF TINT.</b>	
	Strong heavy paper, 40 in. wide, per yard, . . . . .	20
	“ “ 54 “ “ . . . . .	35
495.	<b>MUSLIN BACKED ROLL DRAWING PAPER, BUFF TINT.</b>	
	Strong, heavy paper, 40 in. wide, in 20 yard rolls, per roll, \$15 00, per yard,	90
	“ “ 54 “ “ “ “ 24 00, “	1 40
496.	<b>TRACING OR VELLUM CLOTH.</b>	
	Sager's best, in rolls of 24 yards, 18 inches wide, per roll, \$10 00, per yard,	60
	“ “ “ 36 “ “ 20 00, “	1 25
	“ “ “ 40 “ “ 25 00, “	1 50
	“ “ “ 42 “ “ 27 00, “	1 60
	<b>FRENCH TRACING PAPER.</b>	
	<i>Fine quality, very clear and strong.</i>	
497.	In Sheets. Royal, 19x25 inches, . . . . . per quire,	1 50
498.	“ Super-Royal, 21x26 inches, . . . . . “	2 00
499.	“ Double Elephant, 28x40 inches, . . . . . “	3 00
500.	In Rolls, 11 yards long and 43 inches wide, per yard, .35; per roll,	2 00
501.	“ 22 “ “ “ “ .35; “	4 00

**PROFILE PAPER.**

Having purchased the plates for the Profile, Cross Section and Protractor Paper formerly used by Mr. Hufty of this city, we intend keeping a constant supply of impressions on hand, printed upon fine paper, and will offer them for sale at the following :

502.	Plate A.—Horizontal Divisions, four to the inch, Vertical Divisions, twenty to the inch, and having every tenth horizontal division line and every fiftieth vertical division line heavier than the others. Price per sheet, .	40
503.	Plate B.—Horizontal Divisions, four to the inch, Vertical Divisions, thirty to the inch, and having every fourth horizontal division line and every twenty-fifth vertical division line heavier than the others. Price per sheet,	40
504.	Plate C.—Horizontal Divisions, five to the inch, Vertical Divisions, twenty-five to the inch, and having every fifth horizontal division line and every twenty-fifth vertical division line heavier than the others. Price per sheet,	40

**CONTINUOUS OR ROLL PROFILE PAPER.**

After a long series of experiments, we are now prepared to supply a perfect article of *Profile Paper* in *continuous rolls* of any length, (22 inches wide), and of the following scales :

505.	Plate A.—Horizontal Divisions, four to the inch, Vertical Divisions, twenty to the inch, and having every tenth horizontal division line and every fiftieth vertical division line heavier than the others. Price per yard, .	30
------	---	----

No.	PRICE.
506. Plate B.—Horizontal Divisions, four to the inch, Vertical Divisions, thirty to the inch, and having every fourth horizontal division line and every twenty-fifth vertical division line heavier than the others. Price per yard,	\$0 30
<i>Plate B corresponds to that in sheets known as Brown's Profile Paper.</i>	
506½. Muslin Backed Roll Profile Paper, of either Plate A or B, in rolls of 20 yards, per yard,	75

Every civil engineer who has had the slightest experience in using the Sheet Profile Paper, will at once see the advantages of having it printed in *continuous rolls*, from which sections of any length can be cut as the profile may require.

The subjoined letter gives the opinion of skillful engineers of long standing, in regard to the merit of the Continuous Profile Paper:

PHILADELPHIA, Jan. 31, 1868.

MESSRS. JAMES W. QUEEN & Co.

*Gents*:—We have examined your Continuous Profile and Cross Section Paper, and have no hesitation in pronouncing it a great improvement over the sheet plan in which such papers have been heretofore printed. The want of this kind of profile paper has been much felt for years past, particularly on surveys of long railroad lines, for, in joining the ends of different sheets, we have found it extremely difficult to do it, or have it done with accuracy, on account of the unequal shrinking of the paper in printing and drying; for this reason only, your Continuous Paper will supersede the Sheet Profile Paper; but, in addition, we notice the price of your Continuous Profile Paper is less than we have always paid for the same article in sheets. This, we consider, adds very much to the merit of your invention.

STRICKLAND KNEASS, *Civil Engineer.*  
JOHN C. TRAUTWINE, *Civil Engineer.*  
HENRY MORTON, *Ph. D.*  
W. H. WILSON, *Ch. Eng. Penna. R. R.*

#### CROSS SECTION PAPERS AND LYON'S TABLES.

507. Topographical paper, 14x17 inches, ruled 400 feet to the inch, per sheet, 12 cents,	per quire,	\$1 50
508. Trautwine's Cross Section and Diagram, 10 feet to inch, for embankments of 14 and 24 feet, roadway, and for excavations of 18 and 28 feet, ruling 19½x12 inches,	per sheet,	25
509. Cross Section, ruling 22x16 inches, 8 feet to inch,	"	25
510. 22 Sheets Lyons' Tables for Excavations and Embankments,	"	25
511. Lyon's Tables for Excavations and Embankments, bound,	per copy,	8 50

#### FIELD BOOKS.

512. Level Books, 7x4 inches, made of superior drawing paper,	per dozen	7 50
512½. " 6½x4 " extra smooth paper,	"	4 50
513. Transit Books, 7x4 inches, made of superior drawing paper,	"	7 50
513½. " 6½x4 " extra smooth paper,	"	4 50
514. Record, 7½x5 inches, made of superior writing paper,	"	13 50

#### PAPER PROTRACTORS.

515. Whole Circle Protractors, 12 inches diameter, ½ degrees, thin paper, each,	30
516 " " " " " " on Bristol boards, "	40
516½ Half, " " 5 inches " ½ degrees, each,	25



**OSBORN'S SUPERFINE WATER COLORS, IN WHOLE CAKES.**

No.		per cake, \$1		per cake, \$0	Price.
527.	Purple Madder,	25	Dragon's Blood,	25	
	Gallstone,	1 25	Creams White,	"	25
	Scarlet,	1 25	Emerald Green,	"	25
	Smaltz,	1 25	Gamboge,	"	25
	Pink Madder,	1 15	Green Bice,	"	25
	Carmine, Burnt,	1 15	Green Verditer,	"	25
	Carmine,	1 15	Grey,	"	25
	Carminated Pink,	75	Indian Red,	"	25
	Madder Lake,	75	Indigo,	"	25
	Brown Madder Lake,	75	Intense Blue,	"	25
	Ultramarine,	60	Ivory Black,	"	25
	Cobalt Blue,	60	King's Yellow,	"	25
	Cobalt Green,	60	Light Blue,	"	25
	Indian Yellow,	50	Light Red,	"	25
	Scarlet Lake,	35	Lamp Black,	"	25
	Yellow Lake,	35	Naples Yellow,	"	25
	Crimson Lake,	35	Neutral Tint,	"	25
	Purple Lake,	35	Olive Green,	"	25
	Payne's Grey,	35	Prussian Blue,	"	25
	Permanent White,	35	Prussian Green,	"	25
	Purple,	35	Orange,	"	25
	Sepia,	35	Purple Brown,	"	25
	Drake's Green,	25	Raw Sienna,	"	25
	Antwerp Blue,	25	Raw Umber,	"	25
	Bistre,	25	Red Lead,	"	25
	Black,	25	Red Chalk,	"	25
	Blue Black,	25	Red Orpiment,	"	25
	Blue Verditer,	25	Roman Ochre,	"	25
	Bronze,	25	Sap Green,	"	25
	Brown Pink,	25	Terra Vert,	"	25
	Burnt Ochre,	25	Vandyke, Brown,	"	25
	Burnt Roman Ochre,	25	Venetian Red,	"	25
	Burnt Sienna,	25	Verdigris,	"	25
	Burnt Umber,	25	Vermillion,	"	25
	Cologne Earth,	25	Yellow Ochre,	"	25
	Chrome Yellow,	25	Yellow Orpiment,	"	25
	Chrome Green,	25			

**OSBORN'S WATER COLORS IN BOXES.**

*Neat Walnut Boxes, with Sliding Tops.*

528.	6 rows, 30 colors, whole size, 3 color-cups and 3 brushes,	7 50
529.	5 " 25 " " 3 " "	6 50
530.	4 " 20 " " 2 " "	5 50
531.	3 " 15 " " 2 " "	4 50
532.	2 " 10 " " 3 " "	3 50

*Half Size.*

534.	4 rows, 20 colors, half size, 2 color-cups and 3 brushes,	3 50
535.	3 " 15 " " 2 " "	2 75
536.	2 " 10 " " 3 " "	2 00
538.	Handsome Mahogany and Rosewood Chests, with lock and drawer, paint-stone, water-glass, India ink, brushes, &c., 12 colors,	10 00
539.	" " " " " 18 " "	11 50
540.	" " " " " 24 " "	14 00
541.	India rubber, best quality white, per piece, from	6 to 20
542.	" " " " pure gum, per piece, from	15 to 50
543.	India Ink, best article, small cakes, each,	15 to 50
544.	" " " large " "	75 to 1 25
545.	Mouth Glue, per piece,	5
546.	Gillott's Mapping Pens, per dozen,	85
547.	" Lithograph Crow Quill, on card, per doz.	1 00



## LEAD PENCILS.

No.		Price.
548.	A. W. Faber's Hexagonal Gilt, Nos. 1, 2, 3, 4, and 5, per dozen,	\$1 25
549.	" Pure Siberian Lead, 9 grades, from B to 6 H, very superior, each, 25 cents, per dozen,	2 50
550.	" very small, for divider points, "	75
552.	J. W. Queen's Hexagonal Nos. 1, 2, 3 and 4, per dozen,	60
553.	Camel's Hair Pencils, assorted sizes, per dozen,	50 to 1 00
554.	" " Swan Quill, assorted sizes, per dozen,	2 00 to 3 75
555.	Sable " " 6 sizes assorted, per dozen,	2 50
556.	" " Swan Quill, assorted, per dozen,	10 50
557.	Erasing Knives, each,	50 and 75

## LIST OF BOOKS ON CIVIL ENGINEERING, SURVEYING, &amp;c.

	Prices.	Postage.
563. Gillespie's Land Surveying. The best and latest work published,	\$4 00	36
564. Gillespie's Manual of Roadmaking,	2 00	20
565. Heather's Treatise on Mathematical Instruments. An English Elementary work; Weales' series,	60	8
566. Law and Burnell's Engineering	2 50	20
567. Haupt's Bridge Construction,	4 00	28
568. Smith's Topography,	2 00	16
569. Mahan's Civil Engineering,	4 00	32
570. Mahan's Industrial Drawing,	2 50	24
571. Minifie's Geometrical Drawing,	1 50	12
572. Warren's Draughtsman's Manual,	1 50	12
573. Warren's Draughtsman's Instruments,	1 25	12
574. Warren's Linear Perspective,	1 00	16
575. Armengaud, Amouroux and Johnson. The Practical Draughtsman's Book of Industrial Design, and Machinist's and Engineer's Drawing Companion; forming a complete course of Mechanical Engineering and Architectural Drawing. Rewritten and arranged with additional matter and plates, selections from and examples of the most useful and generally employed mechanism of the day. By William Johnson, Assoc. Inst. C. E., Editor of "The Practical Mechanic's Journal." Illustrated by 50 folio and 5 quarto steel plates and 50 wood-cuts. A new edition, 4to.,	10 00	72
576. Henck's Field-Book for Railroad Engineers, 1 vol., 12mo., Tuck,	3 00	6
577. Byrne. Pocket Book for Railroad and Civil Engineers: containing New, Exact and Concise Methods for Laying out Railroad Curves, Switches, Frog Angles and Crossings; the Staking out of Work, Leveling; the Calculation of Cuttings, Embankments, Earthwork, etc. By Oliver Byrne. Illustrated. 18mo.,	1 25	12
578. Bullock. The Rudiments of Architecture and Building; for the use of Architects, Builders, Draughtsmen, Machinists, Engineers and Mechanics. By John Bullock. 250 engravings. 8vo., cloth,	3 50	32
579. Gregory's Mathematics for Practical Men: adapted to the pursuits of Surveyors, Architects, Mechanics and Civil Engineers. 8vo., plates, cloth,	2 50	24
580. Nystrom's Pocket Book of Mechanics and Engineering, containing a Memorandum of Facts and Connection of Practice and Theory,	2 50	8
581. Practical Surveyor's Guide. By A. Duncan. Illust'd. 12mo., cloth,	1 25	12
582. Railroad Engineer's Pocket Companion for the Field. By W. Griswold. 12mo., tucks,	1 25	8
583. Treatise on a Box of Instruments and the Slide Rule; being a Guide to the Gauger, Engineer, Seaman and Student. By Thomas Kentish. Illustrated by numerous engravings. 12mo., cloth,	1 25	12
584. Becker's Copy Book of Lettering, for Draughtsmen,	4 00	16
585. Trautwine on Railroad Curves. The Field Practice for laying out Circular Curves for Railroads,	2 00	4
586. Trautwine on Excavations and Embankments; A New Method of Calculating the Cubic Contents of Excavations of Embankments, by the aid of Diagrams,	2 00	12



## THE USE OF MATHEMATICAL INSTRUMENTS.

In the foregoing Catalogue we have divided the sets of Drawing Instruments into three classes, viz. : Brass, Fine German Silver, and Extra Fine Swiss. The brass instruments are intended for schools; the fine German silver and the extra fine Swiss instruments for the practical draughtsman.

Without the aid of some drawing instrument, a student cannot obtain a thorough knowledge of Geometry, Trigonometry or Surveying; but, as very few who go over these branches in youth ever make any practical use of them in after life, it is not necessary that the drawing instruments, which are furnished to schools, should be any finer in finish and quality than is sufficient for a clear demonstration of the problems. The sets of brass drawing instruments are equal to all the wants of a young student.

But to the practical draughtsman, his drawing instruments are next to his head and his hands, and they must be of the best material, well and accurately finished. He uses them every day, and all day, and if they are not perfectly correct, the loss and delay occasioned by them, in one instance, will be much greater than the cost of a good set of instruments, which can be used his lifetime.

The fine German silver drawing instruments meet the wants of the practical man.

The extra fine Swiss drawing instruments are more nicely finished than the fine German silver; the metal of which they are made resembles more closely pure silver; they are more substantial in their construction, and consequently more durable. As a general rule, draughtsmen give the preference to the extra fine Swiss drawing instruments.

The fewest drawing instruments a mechanical or architectural draughtsman can possibly perform his work with are the following, viz. :—

- A pair of Plain Dividers, 5 or 6 inches long, as No. 66.
- A pair of Dividers, 5 or 6 inches long, with changeable points, as No. 73.
- A pair of Small Spacing Dividers, as No. 78.
- A Spring Bow Pen, as No. 81.
- A Spring Bow Pencil, as No. 86.
- A Drawing Pen, as No. 87.
- A Drafting Scale.
- A T Square.
- A Triangle.
- A Drawing Board.
- An Irregular Curve.
- Half dozen Fastening Tacks.

An engineer or surveyor can perform his work with fewer drawing instruments. The following list will suffice :—

- A pair of Plain Dividers, 5 or 6 inches long, as No. 66.
- A pair of Dividers, 5 or 6 inches long, with changeable points, as No. 73.
- A Drawing Pen, and a Drafting Scale.

It must be borne in mind, that the above are lists of instruments which are absolutely necessary for the architect and the engineer to have, and without which he cannot follow his profession; but there are many other instruments mentioned in the Catalogue which can be added, and by their aid the work can be much simplified, and more speedily accomplished.

Having made these general remarks we will now proceed to describe each of the drawing instruments—their use, and how to use them.

**THE PLAIN DIVIDERS.**

65

to loosen it.

This instrument consists of two legs, the upper half of which are made of brass or German silver, and the lower half, or points, of tempered steel. In the fine instruments, the joints about which the legs move should be framed of the two different metals—German silver and steel; by this arrangement the wear is much diminished, and greater uniformity and smoothness of motion is obtained. If this uniformity and smoothness be wanting, it is extremely difficult to set the legs quickly apart, at a desired distance; for being opened and closed by the fingers of one hand, if the joint is not good they will move by fits and starts, and either go beyond or stop short of the point; but when they move evenly the pressure can be so applied as to open the legs at once to the exact distance, and the joint must be sufficiently tight to hold them in this position, and not permit them to deviate from it, in consequence of a small amount of pressure which is inseparable from their use. The joints of the dividers are tightened or loosened by inserting the two steel points of the key, into the two small holes on one side of the head of the dividers, and turning from one to tighten it, and in the opposite direction

**THE HAIR-SPRING DIVIDERS.**

When greater accuracy in setting the legs apart is required, than can be obtained



69

by the joint alone, a draughtsman uses the Hair-spring Dividers. The peculiarity of these dividers is, that the upper part of one of the steel points is formed into a bent spring, which being fastened into the German silver portion of the leg, near the joint of the dividers, is made to fit into a groove, cut the whole length of the German silver part of the leg, into which groove this spring can be drawn, or let slip out, by turning the screw on the middle of that side of the dividers.

No. 69 represents the Hair-spring Dividers when shut up; No. 69a represents the same dividers with the spring let a little out of the groove, by loosening the screw.

To take a distance with the Hair-spring Dividers they must be opened as nearly as possible to the required distance; set the leg without spring on the point from which the distance is to be taken, and make the point of the other leg coincide accurately with the end of the required distance, by loosening or tightening the screw on the side of the spring leg.



69a

**THE STEEL SPRING SPACING DIVIDERS.**

In mechanical and architectural drawings, it frequently occurs that a large number of very small equal distances are to be set off, not only at one time, but repeatedly, upon the same drawing; for this purpose the ordinary dividers are too large and inconvenient to handle rapidly, and having nothing but the joint to hold them in their position, are liable to get their extension altered. For such work there is used a pair of very delicate dividers, made altogether of steel, the two legs of which are united at the top by an arched spring, and drawn together or opened by the screw in the middle. On the top of the arched spring an ivory or German silver handle is attached, by which the instrument can be quickly turned over and over, when used in spacing off a number of equal distances. The size of the spacing dividers mostly used are three inches long, with the legs delicately rounded from the regulating screw to the points. The advantages gained by these spacing dividers are, greater nicety and accuracy of adjustment, and no liability of accidental change when once adjusted.



78

**DIVIDERS WITH CHANGEABLE POINTS.**

If an arc or circle is to be described faintly, merely as a guide for the termination of other lines, the steel points are generally sufficient for the purpose; but when arcs and circles are to be drawn permanently, and to show clearly, one point of the dividers must carry either a lead pencil or ink. To accomplish this the steel parts of the legs of the dividers are made so that they can be taken out and replaced by pieces, either for pencil or ink; the small screws in the middle of the legs retain the points firmly in their places. The cut 73 illustrates a set with a pen-point, *a*, a pencil-point, *b*, a dotting-point, *c*, a needle-point, *d*, and a lengthening-bar, *e*.

The pen-point, *a*, consists of two steel blades, so bent that when the points nearly touch each other there is space above for holding ink; the two blades are drawn together or put apart by a regulating screw in the middle. One of the steel blades works upon a joint at its upper end, so that the ink can be thoroughly cleaned off when the pen-point is to be put away, and thereby preventing its being injured by rusting.

To use the pen-point, after securing it tightly in the proper side of the dividers, the ink is put in between the blades by a common writing pen, which should be drawn down and out between the points, then the points of the blades are brought to the proper distance apart for making the line—the closer the points are together the finer the line; the point of the pen must always be as near at right angles to the paper as possible; a joint is made in the German silver part of the point, to regulate the proper inclination.

The pencil-point, *b*, is made of German silver, the lower part of which is formed into a tube; a lead-pencil is placed in this tube, and held tightly by the clamp-screw on the side.

The dotting-point, *c*, is exactly like the pen-point, with the addition of a small toothed wheel, which revolves between the points of the blades, each tooth leaving a dot wherever it touches the paper; and thus, instead of a continuous ink line, a line of dots is made; such lines are meant to illustrate the course of an imaginary line or arc.

The needle-point, *d*, is made similar to the pencil-point; the tube on the lower end is only large enough to take a fine needle, which is held securely in its place by the thumb screw on the side. The needle-point is put in place of one of the steel legs of the dividers, when a number of arcs are to be made from the same centre; it does not deface the drawing by large holes, as the ordinary steel points would. The pen, pencil, dotting and needle-points are all made with a joint near their upper end, in order to bring the points at right angles with the paper.

The lengthening-bar, *e*, is made wholly of German silver, one end of which fits in place of one of the steel legs of the dividers, and the other end has a socket and binding-screw, for receiving and holding the pen, pencil, or dotting-point. It is used when larger circles or arcs are to be drawn than can be made by simply extending the legs of the dividers. The side of the dividers into which the needle-point fits, also the steel point, and the needle-point, are marked on the inside with small dots, to indicate where these points are to be put, when used; those points which are not marked thus, are to be used on the other side of the dividers.

In a large drawing there is always a great amount of finer detail, which can be executed with more accuracy and ease by a set of small instruments. The cut, No. 72, illustrates a set one-half the size of No. 73, but constructed and used in the same manner. It is not provided with the dotting-pen and lengthening-bar. Above the joints of the dividers a handle is attached, by which it can be held and used with more facility than by taking them by the joints, as is done with the large set.

No. 176 represents a set of instruments similar to No. 72, but has a spring over the joints, and a regulating screw in the middle of the legs, by which the points can be opened or drawn together with great nicety and exactness. The handle is of ivory, and much longer than that of No. 72. With No. 176 there are two pen-points; when they are both substituted in

place of the steel points, an instrument for drawing parallel lines is obtained; or, in other words, a railroad drawing-pen, the use of which see cut No. 92, page 41.

**POCKET DIVIDERS.**

It is oftentimes found convenient by the engineer and surveyor to have a pair of dividers for use in the field, which can be carried with safety in the pocket; these are called pocket dividers; the simplest form is a pair of ordinary plain dividers, 5 or 6 inches long, having a German silver sheath, with a blunt point, which screws over the steel points. No. 74 represents this form.



73



72



176



74

Another form of the pocket dividers is so constructed as to include points for pen and pencil, and yet, all contained in a very small compass. No. 79 represents this form. The legs of these dividers are jointed together same as the ordinary plain dividers, but each of them is again jointed about the middle, so that the ends can be folded in towards the upper joint; a deep slot is made in each leg; from their ends, and running almost up to the middle joints in these slots, the steel points are neatly adjusted on pivots; the opposite end of one steel point is finished into a drawing-pen, and the opposite end of the other into a tube for holding the lead-pencil; thus, when the steel points are revolved, either a pencil or pen-point is presented. When not in use, the legs are folded in at the middle joint; the inner sides of the legs of the dividers are filed out to receive the points, so that when they are not in use every delicate part is protected from injury. It will be readily seen, that with the legs of the dividers fully extended, and both of the sharp steel points presented to the paper, that we have an ordinary pair of dividers; by revolving the point which has the

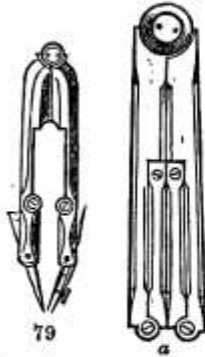

drawing-pen on the opposite end we will then have a pair of dividers with pen-point for describing ink circles; but if we should revolve the other steel point, we should then have a pair of dividers with pencil-point for describing arcs and circles with the lead pencil. Fig. a represents No. 79 drawn on a larger scale, and folded for the pocket.

Another form of pocket dividers is represented by No. 171. The legs are jointed together the same as an ordinary pair of dividers, but instead of being solid they are drilled out from the end almost up to the joint. The steel points, instead of having the pen and pencil-points at their opposite ends, as in No. 79, are jointed in the middle.

When not in use the pen and pencil-points are slipped into the holes in the legs of the dividers, and the steel point bent up against the inside, as represented in the cut. When a pair of plain dividers is wanted, the steel points are turned out straight with the legs of the dividers. When a pair of dividers with pen-point is wanted, the pen is withdrawn from the dividers and the steel point slipped into the hole in the leg; and in the same way the pencil-point takes the place of its steel point, when a lead-pencil circle is to be drawn. For making very small circles, either of ink or lead-pencil, the points can be withdrawn from the legs of the dividers, and used independent of them, as the steel point, with pen-point, of itself is a bow pen, and the steel point, with lead-pencil holder, is a bow pencil.



**THREE-LEGGED DIVIDERS.**

Or, Triangular Compasses, are used for transferring triangular areas from one drawing to another. It is an ordinary pair of plain dividers, with a third leg attached by a universal joint to the face of their joint, so that whatever may happen to be the form of the triangle the legs can be turned to bring each of the points upon one of the angles.

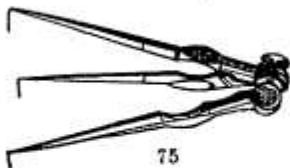

To use the triangular dividers, open the main legs to take in the base, then open and turn the third leg and bring it upon the angle above the base; the legs of the dividers are now set to the form of the triangle, which can be transferred correctly to any other drawing.

**BISECTING DIVIDERS.**

Or, Wholes and Halves, is a pair of ordinary dividers, with the legs continued beyond the joint; the legs, above the joint, being made exactly one-half the length of those below, therefore, when the longer legs are extended to any two points, the distance between the points of the shorter legs will be one-half of that between the longer points. This instrument is very useful when a drawing is to be reduced one-



half, or enlarged double the size of a given copy. If one of the points should get broken it will be necessary to alter all the other points, and keep up the proportion between the short and long legs.

**PROPORTIONAL DIVIDERS.**

This instrument is designed for dividing a line into any number of equal parts; for describing regular polygons in given circles; for reducing or enlarging the area of a drawing, and also for taking the square and cube root of numbers.

The bodies of the legs of these dividers are made of a flat piece of German silver, or brass, with a rectangular opening cut in each, nearly the whole length; the ends of the legs are armed with steel points; the longest two are four or five times the length of the shortest ones. The legs are put together with the rectangular openings exactly opposite each other, and retained in their place by clamp plates and a thumb-screw, which can be moved up and down the opening, and made tight at any desired point; these clamp plates and thumb-screw constitute the joint of the dividers, upon which the legs are opened, and it is easy to perceive that if this joint is exactly half way between the extremity of the points, the two ends will open to the same distance; but if the joint is moved nearer one end, the openings of the points will bear the same proportion to each other as the longer does to the shorter part.

The cheaper form of these dividers (No. 23, page 2,) have but one set of graduations, by which lines only can be subdivided;—the proportions are  $\frac{1}{2}$ ,  $\frac{3}{4}$ ,  $\frac{1}{3}$ ,  $\frac{1}{4}$ ,  $\frac{1}{5}$ ,  $\frac{1}{6}$ ,  $\frac{1}{8}$ ,  $\frac{1}{9}$ ,  $\frac{1}{10}$ ; that is, if the line across one of the clamp plates is made to come opposite either of the divisions on the leg, the two ends of the dividers will open in that proportion.

The best proportional dividers (Nos. 76 & 158, pp. 5 and 10,) have one side of one of the legs graduated for dividing lines into  $\frac{1}{2}$ ,  $\frac{2}{3}$ ,  $\frac{3}{4}$ ,  $\frac{4}{5}$ ,  $\frac{1}{3}$ ,  $\frac{1}{4}$ ,  $\frac{1}{5}$ ,  $\frac{1}{6}$ ,  $\frac{1}{8}$ ,  $\frac{1}{9}$ ,  $\frac{1}{10}$ , and the other side of the leg is graduated for inscribing regular polygons of 6, 7, 8, 9, 10, 11, 12, 13, 14, 15, 16, 17, 18, 19 or 20 sides in given circles. To use the line of polygons, bring the line across the clamp plate to coincide with the graduation which is marked with the number that the polygons is to have sides, then open the dividers, and make the long steel points take in the radius of the circle, then the distance between the small points will be the length of one side of the required polygon. As very few proportional dividers are made with the graduations for enlarging the area of a drawing, and those for taking the cube and square root of numbers, on account of their practical use being very limited and quite complicated, we have concluded to omit their description, and refer those who wish to be informed upon the use of those graduations to Heather's Treatise on Mathematical Instruments, page 5.

The joint of most of the proportional dividers is slipped along the rectangular opening by the hand; but it is frequently quite difficult to bring it exactly to the right place, as a little too much pressure will move the line a little too far, and an opposite pressure may put it too far in the original direction again. For nicety in adjusting the joint to the required point, some proportional dividers are fitted with a bar and micrometer screw, by which the joint can be drawn exactly to the required division. (See No. 159, p. 10.) Another plan is to have a rack fitted on the inside of the rectangular opening, and a pinion attached to the sliding joint, fitting into it; by turning the milled thumb-screw of the pinion the joint is moved up and down in the rectangular opening, with great regularity and exactness. Great care must be taken that none of the points of the proportional dividers get broken, for if one is broken all four must be altered, so that the graduations shall still represent the right proportions.

**BEAM COMPASSES.**

In drawing a circle of very long radius, for which the dividers with lengthening bar are insufficient, the draughtsman is obliged to make use of the beam compass, of which there are two forms. No. 80 represents one form, without the beam, which is made of wood. The main parts consist of two rectangular clamps, of German silver or brass, to the under side of which the points are attached. One of the points is made so that it can be detached, and in its place a point either for ink or lead pencil substituted. To use this form of beam compasses, fasten the metal clamps to the



76



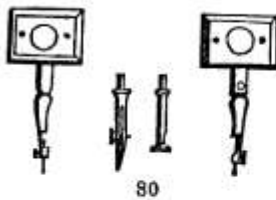

80

edge of a wooden ruler, at the distance apart of the radius of the circle to be described; with one point upon the required centre, the other point is swung around, and the arc or circle completed. Under the whole length of one of the clamps a screw with fine thread and milled head is attached; upon this screw the point is adjusted; by turning the milled head, the point can be made to traverse from one side of the clamp to the other. The object of this screw is, after having adjusted the clamp on the ruler as near as possible, to enable the draughts-

man to bring the points very accurately to the required distance apart by turning it one way or the other.



166

No. 166 represents the other form of the beam compass, in which the bar or rod is of German silver, about one-fourth of an inch in diameter, and divided into two or more sections, with screw joints, for the purpose of convenience in packing away when not in use. The points are attached to German silver tubes, which slide along the rod. One of the tubes can be adjusted to any position on the rod; but the other is fixed at one end, and can only be moved by the adjusting screw to regulate small distances. To prevent the tubes carrying the points from turning on the bar, a groove is cut the whole length of the bar, in which run steel guides projecting from the inside of the tube. When the bars are screwed together, care must be taken to have the groove in each section brought to its right position to make the cut continuous. With these beam compasses there are two round steel points, a needle, pen and pencil points; the needle point fits in place of the round steel point, which is attached to the stationary tube, and the pen and pencil points fit in place of the steel point attached to the movable tube.

#### THE BOW PEN AND BOW PENCIL.

These instruments are indispensable to an architectural or mechanical draughtsman, for describing small circles from one-sixteenth of an inch to two inches in diameter, such as the heads of screws, the hubs and tires of wheels, &c., &c.

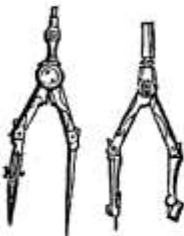

84



85

There are two kinds of bow pens and bow pencils. Those represented by Nos. 84 and 85 are about three inches long, and the legs are extended and closed by the pressure of the fingers; the joint upon which the legs move is the same as in the ordinary plain dividers; one of the legs is made with a permanent needle point, the other leg is a pen or pencil point; both legs are jointed in the middle, so that the points can always be set at right angles to the paper.



81



86

The other and best form of bow pen and bow pencil is that with spring and adjusting screw. Of these there are two kinds. Those represented at Nos. 81 and 86 are made wholly of steel, except the handle, which is either of Ivory or German silver. The legs are made of one straight piece of steel, which is bent in the middle until the two points come within one inch of each other, and then highly tempered. A steel wire, three-fourths of an inch long, having a fine thread cut on it, is fastened to the middle of one leg, and passes through the other; a small German silver nut is screwed on the end of this wire, and pressing against the leg, forces the points closer together; the parts of the legs above the screw being of tempered steel, when the nut is loosened, the points will move back with it.

The other form of the spring bow pen and bow pencil is represented by Nos. 82 and 83. The leg, body and handle are made of one piece of German silver or brass, three inches long; the

lower end of the leg is finished with a small tube and clamp screw, for receiving and retaining a needle point; the body is almost twice the width of the leg, and a groove is cut the whole length of one of its sides; the pen or pencil point is attached to a tempered steel spring, the end of which is screwed fast into the upper end of the cut in the body; a steel wire, half an inch long, with a fine thread cut on it, is fastened into the body, and passes through the spring just above the pen or pencil point; a nut is screwed on the end of this wire, and bears against the spring and forces it in or lets it out of the cut in the body, which brings the pen or pencil and the needle point nearer together, or puts them farther apart. No. 82 represents the bow pen; the bow pencil is constructed in the same manner, but has a point for lead pencil instead of ink. No. 83 has both a pen point and a pencil point, and by simply changing one point for the other, can be used as a bow pen or bow pencil.



#### DRAWING PENS.

This is a most important instrument to every draughtsman, and should be well made and always kept in good order. It consists of two steel blades, attached to an ivory handle, and so bent that when the points are almost touching, there is space between the blades for holding ink. One of the blades is hinged where it joins the handle, so that it can be opened away from the other blade when it is to be cleaned. A steel screw, having a German silver head, is passed through the hinged blade and screws into the other blade; by turning this screw the points can be brought to the distance apart for making the required thickness of line. There are three sizes of these pens, viz.:  $4\frac{1}{2}$  inches,  $5\frac{1}{2}$  inches, and  $6\frac{1}{2}$  inches long from the point of the pen to end of handle. To use the drawing pen, put the ink between the blades with a common writing pen, drawing it down and out between the points of the blades; screw the blades to the proper distance apart for making a line the required thickness. In drawing the line, the pen should be held firmly against the ruler, slightly inclined in the direction the line is being drawn; the points of both blades must touch the paper. The handles of most drawing pens are made to unscrew, and a needle is fitted in the screw end, which can be used for pricking drawings from one paper to another.



When lines of red ink are to be drawn, it is found best to use a drawing pen having the blades made entirely of German silver instead of steel, as the acid in the ink does not act upon and injure the German silver as quickly as it does the steel.

#### RAILROAD DRAWING PEN.

For drawing close parallel lines in mechanical and architectural drawings, or to represent canals and railroads, a double drawing pen is used. It consists of two drawing pens attached parallel to each other on one handle; the distance of the two pens apart is regulated by the adjusting screw between the end of the handle and the top of the pens.

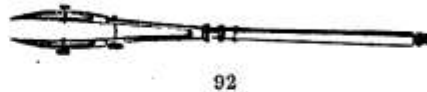

#### DOTTING PEN.

The dotting pen is made like the drawing pen, but has a finely toothed wheel, which revolves between the points, and instead of a continuous ink line, it makes a dot for each tooth, and consequently, a line of dots, when drawn between two points. It is used when imaginary lines are to be shown on the drawing.



#### MAP PERAMBULATOR.

The map perambulator is used for measuring the length of curved lines, such as the courses of rivers and roads, &c., &c. It consists of a finely toothed wheel, about three-fourths of an inch in diameter, working back and forwards upon a fine steel screw; the screw is supported in a neat German silver frame, to which an ivory handle is attached. To use the instrument, screw the wheel against the side of the German silver frame,

from which a point projects almost to the lower edge of the wheel, then roll the wheel along the crooked line until it reaches the end; then go to the scale on the edge of the map or drawing, and roll the wheel back to the side of the frame from which it was started, and the length of the crooked line will be ascertained.

Every draughtsman should provide himself with a fine oil stone for dressing the points of his dividers and pens, so as to keep them always in perfect working order; he should also have a fine piece of buckskin, for wiping the instruments off before returning them to the case. In handling and using the instruments, the steel parts should come in contact with the fingers as little as possible, as the perspiration rusts the steel, but does not materially injure the brass or German silver.

#### THE PROTRACTOR

Is used for plotting surveys and laying off angles in general. Nos. 210 and 215 represent semicircular pieces of horn, brass or german silver, on the middle of the

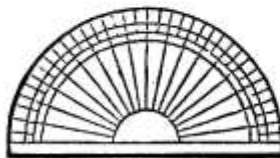

210

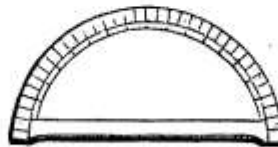

215

diameter of which a dot or small cut is made, indicating the centre; the edges are divided into 180 parts or degrees, or 360 parts or half degrees; the best protractors are always divided in half degrees. The horn protractors are made of a solid piece of horn, rolled as thin as

writing paper; they are transparent, and the lines for each ten degrees are drawn almost from the centre to the edge (see No. 210). To reduce the weight of metal protractors, and render them more convenient to use, a semicircular piece is cut out, leaving all round an edge one-half to three-quarters of an inch across; the circular edge is then divided in degrees or half degrees (see No. 215).

To protract a survey, draw a north and south line, and take a point about the middle; bring the centre of the protractor over this point, and make the straight edge come even with the line; now set off the bearings on one side of the line for eastings, and on the other for westings; then remove the protractor, and draw faint lines from the centre to the points marked off, and with the parallel ruler, dividers and scale, bring the lines to connect, and form a figure of the survey. To set off an angle from a given point on a given line, bring the centre of the protractor to the point, and make the edge come on the line; then with the point of the dividers mark on the paper where the required degree comes, and draw a line from the given point to that point, and the angle made by the two lines will contain the required number of degrees.

There is always more or less difficulty in marking off the degrees from the protractor, with the point of the dividers, to do it accurately and distinctly, so that when the protractor is removed, the direction of the required line can be readily seen. To obviate

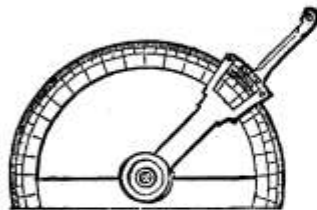

232

this difficulty, the protractor with arm is made; the arm is simply a ruler of the same material as the protractor, jointed to the centre, so that it can be revolved from one side to the other; it projects about three inches beyond the edge of the protractor. After sitting the protractor on the line with its centre over the point from which the line is to start, bring the beveled edge of the arm to the required degree, and with the point of the pencil resting against that edge, draw a straight line; now, when the protractor is removed, there is no doubt about the position and direction of the line.

The protractor with arm is divided in half degrees, and with it angles can be laid off correctly to fifteen minutes, but when great accuracy is to be observed, and the angles are required to be laid off to the very minute, a vernier must be attached to the arm. It is made by widening the arm, and cutting a square opening in it at the part where it crosses the edge of the protractor; the edge of the opening which meets the graduated edge of the protractor, is divided in such a manner as to enable the parts of a degree less than thirty minutes to be accounted for correctly, when laying off the angle. For a general description of verniers, see Gillespie's Land Survey, Chapter II., page 228.



A whole circle protractor is made and used the same as the half circle; ~~it is~~ in reality, two half circle protractors, having the same diameter.

The bevel protractor is made of steel; it is half circle and with arm; its straight edge projects beyond the arc both ways. The arm, instead of being fastened permanently at the centre, as is the case in other protractors with arms, has a narrow opening cut in it, almost from one end to the other; the arrangements which hold the arm to the protractor fit in this cut, and a clamp nut retains it in its place by loosening the clamp nut the arm can be slipped so as to project above the arc, or below the straight edge, as may be wanted. This protractor is intended for the use of machinists, in obtaining or laying off bevels upon a piece of machinery.

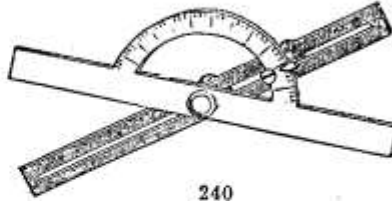

240

#### RECTANGULAR PROTRACTOR.

This form of protractor is generally made of ivory, and six inches long, by one and three-quarters to two and a half inches wide; three edges of one side are divided in parts corresponding to the degrees and half degrees of the semi-circular protractor, the other edge has a division half way between the ends which represents the centre of the circle and the point in which the lines around the three edges would all meet, if continued. To understand the graduations around the edges, take a half circle protractor and bring its centre to the mark on the side not graduated, and make its straight edge correspond with that side; now, it will be found that where the graduations on the edges of the two protractors come in contact they represent exactly the same number of degrees; and if the other lines on the rectangular protractor were continued they would meet the corresponding ones on the semi-circular protractor. This protractor is used for the same purposes and in the same manner as the semi-circular protractor.



264

Besides the protracting scale around the edges, one side of the rectangular protractor has on it a diagonal scale of equal parts, and scales of 20, 25, 30, 35, 40, 45, 50 and 60 equal parts to the inch; also, a scale of chords for arcs of a circle four inches diameter; on the other side are scales of  $\frac{1}{8}$  in.,  $\frac{1}{4}$ ,  $\frac{3}{8}$ ,  $\frac{1}{2}$ ,  $\frac{5}{8}$ ,  $\frac{3}{4}$ , 1,  $1\frac{1}{8}$ ,  $1\frac{1}{4}$  in., each subdivided into twelve parts; also, a scale of chords for arcs of a circle six inches diameter; the edge which has the centre mark on it is divided into forty parts to the inch.

The diagonal scale consists of a series of eleven parallel and equi-distant straight lines; across these, and at right angles to them, another series of lines are drawn, having the spaces between every two lines to measure exactly one-quarter of an inch. The top and bottom line of the eleven parallel lines have the first quarter of an inch divided into ten equal parts, also, the last half of an inch. A line is drawn from the first of these small sub-divisions of the first parallel line diagonally across the other nine lines, to the beginning of the sub-divided part of the lower line; and from each of the other sub-divisions of the upper line, lines are drawn parallel to the first diagonal line. It is readily seen, that at the point where one of these diagonal lines crosses each one of the nine parallel lines, it increases its distance from the perpendicular line by one-tenth of one of the small sub-divisions for every parallel line.

To take off distances of two figures, say 46,—chains, feet or miles,—place one point of the dividers at the fourth perpendicular line on the top parallel line, and open the dividers to the sixth sub-division at the beginning of the line. If we have three places of figures to take off, say 467,—chains, feet or miles,—open the dividers as before, along the top line, from the fourth perpendicular line to the sixth sub-division; now bring the point of the dividers down the fourth perpendicular line to the seventh parallel line, the other point of the dividers then will not be on the intersection of the sixth diagonal line and the seventh parallel line; but when it is opened to that point the dividers will take in the required distance, viz., 467

**GENERAL RULE.**—To take off any number to three places of figures from a diagonal scale: on the parallel line, indicated by the third figure, measure from the diagonal line, indicated by the second figure, to the perpendicular line, indicated by the first figure.

**ENGINEER'S CHAIN SCALES, OF EQUAL PARTS,**

Are those which have one inch, or a portion of an inch, divided into a number of equal parts; they are marked 20, 25, 30, 35, 40, &c., &c.; and it is to be understood that each one of the fine divisions at the beginning of the lines is that part of an inch represented by the figures before the line; that is, if 20, each one is the  $\frac{1}{20}$  of an inch, and if 40, each division is the  $\frac{1}{40}$  of an inch. There are but ten of the finer divisions marked off at the beginning of each line, after that, each graduation represents ten of the very small ones. On the ivory protractors, and the scales usually with sets of instruments, it will be found that there is another set of divisions over the fine ones, on each line; these divide the first large space into twelve equal parts.

The measuring chains used by engineers are fifty or one hundred feet long, and each link one foot long; therefore, if each one of the large divisions on the scales is called a chain, the fine divisions will each represent ten links, if the chain used be one hundred feet long, and five links, if a fifty foot chain is used. The size of the drawing is therefore regulated by the selection of one of these scales to lay off the length of the lines by. If the measures are in feet and tenths of a foot, each of the large divisions can be called one foot, and each of the fine divisions will be one-tenth of a foot. If the measure is in feet and inches, each one of the large divisions can be called one foot, and each one of the twelve fine divisions above the other fine divisions, will be one inch.

**ARCHITECT'S SCALES, OF EQUAL PARTS.**

In making a plan of a building or a drawing of a piece of machinery, it is necessary to make a small fraction of a foot represent a line, which, in reality, measures a whole foot; the scales mostly used for this purpose are  $\frac{1}{16}$  of an inch,  $\frac{1}{32}$ ,  $\frac{1}{4}$ ,  $\frac{3}{8}$ ,  $\frac{1}{2}$ ,  $\frac{5}{8}$ ,  $\frac{3}{4}$ , 1,  $1\frac{1}{2}$ , and 3 inches to the foot; that is, every 16th of an inch is laid off the whole length of the scale, to represent feet, and the first 16th is divided into twelve equal parts, to represent the inches; and the same with the  $\frac{1}{32}$ , and all the other divisions to 3 inches to the foot.

**SCALE OF CHORDS.**

The chord of an arc is a straight line joining the two extremities of the arc. The graduations on the scale of chords represents the length of the chords of all arcs, from one degree to ninety degrees. The chord of an arc of sixty degrees is always equal to the radius or half the diameter of the circle. The chord of sixty is always used for describing arcs for laying off angles, or measuring angles already laid off.

On some of the ivory scales there are found a number of other graduations, marked Rhu., Lon., Sin., Tan., S. T., Lat. These initials stand for Rhumbs, Longitudes, Sines, Tangents, Semi-Tangents, and Latitudes. As these are only used in the study and application of navigation we will omit describing them here, and refer those who wish to know their application to Heather's Treatise on Mathematical Instruments, page 16.

The scales described in the preceding pages are those usually found on the six inch ivory protractors, and six inch ivory scales. As a general rule, draughtsmen would prefer scales of greater length than six inches, and with only a certain class of divisions on them. The Ivory Chain Scale is twelve inches long, and has two edges bevelled, and graduated either to 10 and 10 parts to the inch, or 10 and 20, and so on up to 100 parts to the inch; the fine graduations being continued the whole length of scale.

The Triangular Chain Scale is made of well-seasoned boxwood; the six edges are graduated each with a single scale, viz: one edge has 10 parts to the inch, one 20 parts, one 30 parts, one 40 parts, one 50 parts, and one 60 parts.

The Triangular Scale for architects has five edges, graduated with two scales on each edge, as follows: one

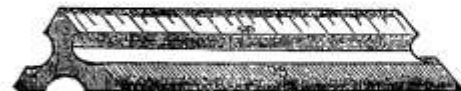

277

edge has each  $\frac{3}{8}$  of an inch, and each  $\frac{1}{8}$  of an inch marked off; the  $\frac{3}{8}$  are numbered from one end and the  $\frac{1}{8}$  from the other. One edge has each  $\frac{1}{2}$  of an inch, and each  $\frac{1}{4}$  of an inch; one edge has each  $\frac{3}{4}$  of an inch, and each  $\frac{1}{4}$  of an inch; one edge has each  $\frac{1}{2}$  of an inch, and each an inch; one edge has every  $1\frac{1}{2}$  inches, and every 3 inches; and one edge is divided into inches and 16ths of an inch. The first division of the  $\frac{3}{8}$  scale is divided into four equal parts; consequently, if the  $\frac{3}{8}$  represent one foot, each of the sub-divisions will represent 3 inches. The  $\frac{1}{8}$ ,  $\frac{1}{4}$ , and  $\frac{3}{8}$ , have the first division

divided into twelve equal parts; therefore, if the primary division represent one foot, each of the sub-divisions will represent one inch. The  $\frac{1}{2}$  and  $\frac{3}{4}$  of an inch have the first division divided into twenty-four equal parts; therefore, if the primary divisions represent one foot, each of the sub-divisions will represent the half of an inch. The 1 inch and  $1\frac{1}{2}$  inches have the first division divided into forty-eight equal parts; and if the primary division represent one foot, each of the sub-divisions will stand for one-quarter of an inch. The 3 inches has the first division divided into ninety-six equal parts; and if the primary division represent one foot, each of the sub-divisions will represent the one-eighth of an inch.

The Ivory and Boxwood Flat Architect's Scales, Nos. 260 and 274, are 12 inches long by  $1\frac{1}{2}$  inches wide, and have the following divisions on them, viz.:  $\frac{1}{8}$ ,  $\frac{1}{6}$ ,  $\frac{1}{4}$ ,  $\frac{3}{8}$ ,  $\frac{1}{2}$ ,  $\frac{5}{8}$ ,  $\frac{3}{4}$ ,  $\frac{7}{8}$ , 1,  $1\frac{1}{4}$ ,  $1\frac{1}{2}$ ,  $1\frac{3}{4}$ , 2,  $2\frac{1}{4}$ ,  $2\frac{1}{2}$ ,  $2\frac{3}{4}$ , and 3 inches to the foot; the  $\frac{1}{2}$ ,  $\frac{3}{4}$ ,  $\frac{1}{2}$ , and 1 inch divisions are graduated on the two edges of one side; all the other divisions are laid off on the body of the scale. The primary division of each scale is divided into twelve equal parts, to represent inches; and in the  $\frac{3}{8}$ ,  $\frac{5}{8}$ ,  $\frac{3}{4}$ ,  $\frac{7}{8}$ ,  $1\frac{1}{4}$ ,  $1\frac{1}{2}$ ,  $1\frac{3}{4}$ , 2,  $2\frac{1}{4}$ ,  $2\frac{1}{2}$ ,  $2\frac{3}{4}$ , and 3 inch scales, the primary divisions of each is also divided into ten equal parts, by faint dots over the twelve parts; each one of these represent the one-tenth of a foot, when the primary division is taken for one foot.

The Ivory and Boxwood Architect's Scales, with 16 different graduations, all brought to the edge. Nos. 262 and 275 have the same graduations on them as Nos. 260 and 274; but have them arranged in such a manner that the divisions of each graduation come out to one or the other of the four edges. The advantage of having the graduations on scales come out to the edges is, that the edge of the scale can be brought to the line, and the required distance marked off without taking it with the dividers, thereby insuring greater accuracy and less trouble.

#### PAPER SCALES.

A very convenient though not very lasting scales; are printed from copper-plates on strips of card-board; they are nineteen inches long by one and a half inches wide; each strip has but one scale on it, and that on one edge. They are usually put up in sets of six, thus:  $\frac{1}{4}$ ,  $\frac{1}{2}$ ,  $\frac{3}{4}$ , 1,  $1\frac{1}{2}$ , and 3 inches to the foot, for series A; and  $\frac{1}{32}$ ,  $\frac{1}{16}$ ,  $\frac{1}{8}$ ,  $\frac{1}{4}$ , and  $\frac{1}{2}$  of an inch to the foot, for series B; and 10, 20, 30, 40, 50, and 60 parts to the inch, for series C. These scales being made of the same material as the paper upon which the drawing is made, the expansion and contraction, from moisture and heat, are equal upon both; another advantage is, they are not as liable to soil the paper as scales made of other material.

#### STEEL RULES, OR SCALES.

These scales are intended for the use of machinists, in making nice measurements on delicate work. They are made of steel, and divided into inches on all four of the edges; the first inch on one edge is divided into 16 equal parts, the next inch into 32 equal parts, and the next into 64 equal parts. Another edge has the first inch divided into 20 equal parts, the next inch into 50 equal parts, and the next inch into 100 equal parts. Another edge has the first inch divided into 12 equal parts, the next inch into 24 equal parts, and the next inch into 48 equal parts; and the fourth edge has the first inch divided into 8 equal parts, the next inch into 14 equal parts, and the next inch into 28 equal parts.

#### THE SECTOR.

These are usually made of two pieces of ivory, each six inches long, and jointed together like the carpenter's rule; it is an instrument but little used at the present time, and therefore we will not attempt to enter into a description of it here, but refer for complete information about its construction and use, to Heather's Treatise on Mathematical Instruments, page 34.

#### STRAIGHT EDGES,

Are rulers, the edges of which are very carefully finished, to enable the draughtsman to draw a perfectly straight line. They are made of some kind of hard wood or metal. The metal ones can be made more accurately than the wooden ones, because their edges can be ground on iron plates, with emery, and finally finished by grinding the edges of two rules together, also with emery.

In order to ascertain whether a straight edge is perfectly true, take two of them and place one edge of one against an edge of the other, and hold them up between the eye

and the light, and observe if any light can be seen between the edges; all the edges should be tried in the same manner.

#### TRIANGLES

Are used for laying off angles, and with a straight edge for drawing parallel lines. They are made of hard wood or metal, and are either solid or with open centre; the angles are usually 30, 60, and 90 degrees, or 45, 45, and 90 degrees; the length of the sides vary from 5 to 12 inches. The wooden triangles are lighter, less expensive, and less liable to soil the paper than the metal, but cannot be made so accurately; the wood triangles are also apt to warp and become incorrect by wear in using. The advantage of the open over the solid triangles is, when of wood that they are less liable to warp, and if of metal they are lighter; besides these reasons, they do not conceal so much of the drawing, and in using them the draughtsman can see better how to draw his lines. To see if the right angle of a triangle is correct, draw a straight line, and bring the edge of one of the sides exactly on it, having the right angle about the middle of it; then draw a line along the other side, from the right angle; now, it is to be supposed there is a right angle on each side of the last line drawn: to prove it, take up the triangle and place it in the same position it occupied before, but on the opposite side of the last line; now, if the angle of the triangle is not 90 degrees, when one side corresponds with its line the other will not. To prove the angle of 30, see if it is one-third of ninety, and the angle of 60 should be double of the 30 angle.

The edges of the triangle can be tested in the same manner as the edges of a straight edge. The simplest way to test the right angle of a triangle, is by the right angle of the T square, one edge of the triangle being held against the blade and the two right angles brought together; the other side of the triangle should fit evenly on the head of the T square; the other plan is the most correct, as there may be an error in the angle of the T square. The triangle is one of the most useful articles in a draughtsman's set of instruments.

#### IRREGULAR CURVES

Are made of wood or horn; a variety of curves are cut upon the outer edges, and pieces are cut from the body in such a manner that there is a curve for every side of the opening. These curves are much used in design drawing, also for architectural drawing; some little use is made of them in civil engineering.

#### T SQUARES

Are usually made of hard wood, and are of three different kinds. The first kind has the cross-piece or head fastened permanently and securely at right angles to the straight edge or blade. The second kind has the head attached to the blade by a clamp-screw, which allows the head to be fixed at any angle to the blade, and firmly clamped where fixed. The third kind has the head permanently and securely fastened at right angles to the blade, and a secondary head of the same size attached to it with a clamp-screw, and thus, when other angles than right angles are to be made, the movable head can be fixed at the proper inclination to the blade, while a right angle is still maintained by the fixed head. In the first two kinds the blade is fixed to one of the flat sides of the head, and when used, the edge of the head comes against the side of the drawing board, while the blade lays evenly on it; in the third kind the blade is attached between the two parts of the head, so that in using either the fixed or movable side there is an edge to come against the drawing board, while the blade rests on the board.

The T square is always used in connection with a drawing board, and with it and a triangle all the straight and parallel lines of a drawing are very easily added; the head of the T square being held against the edge of the board, and the triangle resting against the edge of the blade, along which it can be slid for making parallel lines; by sliding the head along the edge of the drawing board other parallel lines can be drawn. The edges of the blade of the T square are apt to get rough from constant use; to prevent this, and also to make the blade stiffer and less liable to warp, a thin strip of brass is set into the edges, and finished off smooth and true.

The angles of the T square should be tested in the same manner as the angles of a triangle, and the edges of the blade as the edges of a straight edge.

**PARALLEL RULERS**

Are of two kinds; the first and most common consists of two straight edges, of ebony or metal, from six to twenty-four inches long, by three-quarters of an inch to one and a half inches wide, joined together by two parallel strips of brass, which move upon pivots at the points where they are attached to the rulers; thus, when the bars are put apart they are always held parallel to each other by the brass strips, consequently, if the edge of one of the bars is brought to a line, and firmly held there, and the other bar pushed away from it, a line or lines drawn by the second bar will be parallel to the original line.

**ROLLING PARALLEL RULERS.**

The other form is a solid straight edge, from nine to eighteen inches long, by two inches wide, made of a thick piece of ebony wood, or metal; this is mounted upon two small rollers, of equal diameters, one near each end, and both revolving upon one axis. If one edge is brought to a line, and the ruler is pushed from it, the two rollers being of equal size, and on the same axis, will move both ends along the paper with equal rapidity; and any lines drawn in the new position will be parallel with the first line.

Some of this form of parallel rulers have the edges graduated, which is very convenient in many kinds of drawings; the circumference of the wheels are often graduated for the purpose of drawing a number of parallel lines at the same distance apart.

**FASTENING TACKS**

Are small nails used for fastening the paper to the drawing board; they have large flat heads and very small sharp points; the heads are round, and made of brass, German silver, or steel, and the points of the best tempered steel, carefully sharpened. In putting them into the drawing board, the point should be well started with the fingers, and the pin pushed home with a small bottle cork. If the thumb is used for pressing them in there is danger of the upper part of the pin coming through the head, and injuring the thumb.

A new form of fastening tack has just been introduced; it is a right angled piece of metal, each side of which is one-half an inch long, with three points; it is intended for fastening the paper at the corners.

**HORN CENTRES**

Are circular pieces of very thin semi-transparent horn, about one-half an inch in diameter, with very short and delicate steel points projecting from one side. They are used to put over the point which is to be the centre of several circles or arcs; the centre point can be seen through the horn, and the point of the dividers can be put directly on the centre point; but the paper is shielded from being punctured and disfigured by frequent use of the same hole as a centre.

**THE DRAWING BOARD**

Is a rectangular frame of walnut, with an open centre, into which a soft pine board, carefully planed and perfectly smooth, is fitted, and fastened in with buttons. The frame is made of hard wood, so as not to wear easily and become incorrect, and the centre of soft wood, so that the fastening pins can be easily put in. The angles and edges of the frame should be as correct as possible; though a little inaccuracy in these respects is not very important, as only one side is used for resting the head of the T square against, and the lines which would require another side to be used are added with the triangles and the dividers.

**AMSLER'S POLAR PLANIMETER.**

By means of AMSLER'S POLAR PLANIMETER a person entirely ignorant of Geometry, may ascertain the area of any planimetric figure, no matter how irregular its outlines may be, more correctly and in much shorter time than the most experienced Mathematician could calculate it.

The management of the Instrument can be easily learned in half an hour, and in size it is no larger than a two feet folding rule.

The Planimeter indicates square feet or square inches, and acres for surveying.



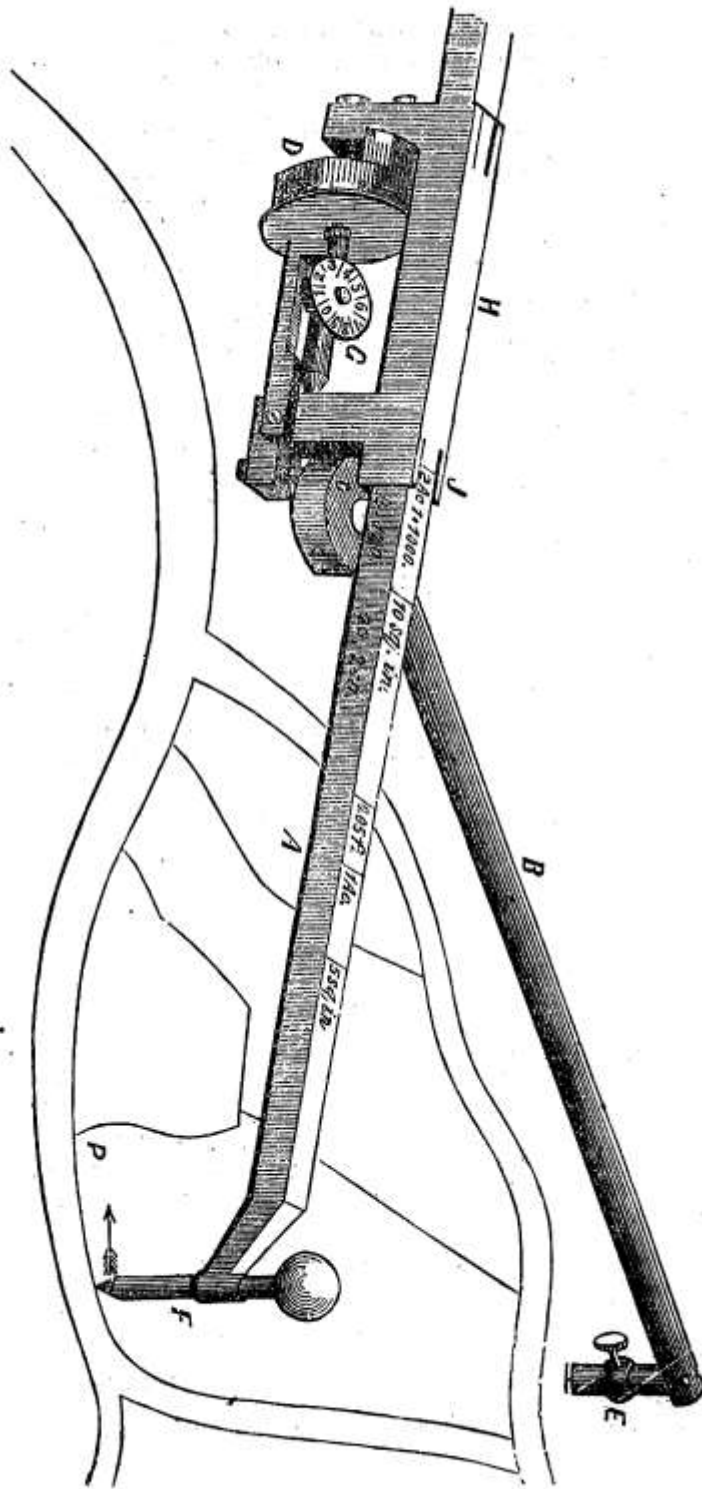

**DIRECTIONS.**—Preparatory to the use of the Instrument, ascertain its state:—The Index roller D must play easily without coming in contact with the nonius, (or vernier.) The screw centres on which its axis revolves must be adjusted, so as to allow perfect freedom of rotation; the same is to be observed for the centre pin C.

The needle point E ought to project but very little from its socket. Great care must be taken not to bend any part of the instrument.

To ascertain the area of a figure in square inches, slide the square rod A into the tube H, so that the line marked 10 sq. in. (10 square inches,) stands fair with the bevelled part of the tube J. Then set the instrument on the paper, so that the index roller D, the tracing point F, and the needle point E rest on the paper; press the latter point a little on the paper, not enough to pierce it through. This point is to remain stationary during the whole operation. Set the tracing point F on any point P of the outline, and mark that point, and read off the state of the counting wheel G, and the index roller D. Suppose the counting wheel indicates 3 (as in cut,) the index roller 905 (90 degrees to be read on the index roller, and 5-10 on the nonius) so that the O of the nonius stands on 90 5-1000 of the circumference of the index roller. Write down the number just read off thus, 3,905.

Now follow with the tracing point F, the outline of the figure, or part of the figure, to be measured, with great exactness, in the same direction as the hands of a watch would move, until you arrive at the starting point.

Strait lines may be followed along a rule; then read off again the state of the indicators. Suppose you find now 5,763, i.e. the counting wheel indicating 5, and the index roller and nonius 76 3-10 degrees. From these two readings the area found is to be obtained, and here two points are to be considered.

**A.** If the needle point E is outside of the figure just traced round, the first number (3,905) is to be deducted from the second number (5,763.)

5,763	
3,905	and the remainder (1,858) is to
be multiplied by ten equal	
18,580	
18,580	which is the area desired, 1,858

**B.** If the needle point E is inside of the outlines of the figure, add to the number last read off (5,763) the number marked on the side of the square rod next to where 10 sq. in. is marked on the upper side.

In this case it is 20,240, the last number	5,763	read off
The number on side	20,240	
	26,003	Deduct from this
amount the number first read off	3,905	
	22,098	

Multiply this remainder by ten, equal 220,98, and this is the amount of square inches, or area of the measured figure.

It is of no consequence whether the roller moves inside or outside of the outlines of the figure, provided it moves on a smooth surface even with the figure.

To obtain the area in square feet, slide the square rod into the tube up to the line marked 0,1 sq. ft. or 0,5 sq. ft. In this case the difference between the first and second readings of the indicators is to be multiplied by 0,1 or 0,05. If the difference, for instance is 4,653, the rod being up to the line marked 0,1 sq. ft., then is  $4,653 \times 0,1 = 0,4653$  equal to the area in decimal fractions of a square foot.

If the needle point is within the outlines of the figures as described in B, proceed the same way as at B, but multiply by 0,1 or 0,05.

If the figure to be measured is at a reduced scale, the result has to be multiplied by the square of the proportion of the reduction. If the proportion of the figure to the full size is as 1 : 10, the result is to be multiplied by  $10^2 = 100$ —for instance: the result of the first example is 1,858, which multiplied by 100,  $(1,858 \times 100) = 1858$  sq. inches, would be the amount of the area.

If the amount of acres is to be ascertained, the proportion of the reduction being 1 : 1000, slide the square rod up to the line marked 2 ac. 1 : 1000, or 1 ac., and operate as indicated above; the result is to be multiplied by 1 or 2 instead of 10 or 5. If the rod is set up to the line marked 1 ac., no multiplication is necessary.

Should the plan of the piece of land be drawn on a smaller scale than 1-1000, for ex-

ample 1-5000th, then multiply the result with the square of the proportion of the reduction to the scale of 1-1000. Thus for the scale of 1-5000 the result would have to be multiplied by  $5 \times 5 = 25$  (1-5000 being to 1-1000th as 5-1.) If the scale is 1-500th multiply the result by  $\frac{1}{2}^2 = \frac{1}{4}$ , that is to say, divide the result by 4.

*Remark.*—If on reading off the horizontal or counting wheel G, the indicator points near the middle line between two figures, say between 3 or 4, then see how the index roller stands to the nonius. If the 0, on the nonius is on the lower side of the 0 of the roller, therefore near 100, then read 3, but if the 0 on the nonius is on the upper side, therefore near 0 on the roller, then read 4 for unity.

If the horizontal wheel turns on its axis during the tracing operation, so that it goes beyond 0 (in fact 10), and even marks several revolutions and then stops at any number, for instance 7, you read 17 or 27, &c., adding as many times ten as the wheel has made full revolutions.

It is easy to notice the number of revolutions. If the wheel G marks 6, and the roller D is for instance on 0 degrees, 7-10 degrees, or on 4 degrees, 7-10 degrees, then the reading is of course 6,007, or 6,047. The number read off the nonius always taking the third place after the units.

The cut shows the instrument two-thirds the natural size.

Draftsmen, Engineers, Surveyors, Ship Builders, Architects, Machinists, will please devote a few moments only to the examination of this instrument, and they will at once be convinced of its great importance and value.



(The greater portion of the following pages we have been kindly permitted to copy from Messrs. W. & L. E. Gurley's very excellent book, the "AMERICAN ENGINEERS' AND SURVEYORS' MANUAL.")

For a full and complete description of the Solar Compass and Engineers' Transit, alluded to in the text, see the Manual as above.

## Surveying Instruments.

THE various instruments used in Surveying may be conveniently arranged, into two general divisions.

(1.) NEEDLE instruments,—or such as owe their accuracy and value to the magnetic needle only, embracing the Plain and Vernier compasses, and the Vernier Transit.

(2.) ANGULAR instruments, including those in which the horizontal angles, are measured by a divided circle and verniers, as well as by the needle also; as the Railroad Compass, the Surveyors' and Engineers' Transits, &c.

In the present work we shall consider first, those instruments comprised in the first division, and, as in these the accuracy of the horizontal angles indicated, depends upon the delicacy of the needle, and the constancy with which it assumes a certain direction, termed the "magnetic meridian," we shall here remark briefly upon the *form*, the *length*, and the *movement* of

THE MAGNETIC NEEDLE.—The *forms* of the needle are almost infinitely varied, according to the taste or fancy of the maker or surveyor, but may be resolved into two general classes, one having the greatest breadth in a horizontal, the other in a vertical direction.

We have usually made our needles about one-twentieth of an inch broad and one-third as thick, parallel from end to end, the north and south poles being distinguished from each other, by a small scollop on the north end.

Of course the form of the needle is always varied according to the choice of our customers, and without additional charge.

The *length* of the needle varies in different instruments, from four to six or even seven inches, those of five and a half, or six inches long, being generally preferred by surveyors

The *movement* of the needle, with the least possible friction, is secured by suspending it, by a steel or jewel centre, upon

a hardened steel pivot, the point of which is made perfectly sharp and smooth.

The test of the delicacy of a magnetic needle is the number of horizontal vibrations, which it will make in a certain arc, before coming to rest—besides this most surveyors prefer also to see a sort of quivering motion in a vertical direction.

This quality, which is manifested more in a horizontal, than in a vertical needle, and depends upon the near coincidence of the point of suspension with the centre of gravity of the needle, serves to show merely that the cap below is unobstructed.

Having now considered the different qualities of a good needle, we shall proceed to speak of those instruments of which it makes so important a part of these, the most simple is that termed the

#### PLAIN COMPASS.

No. 372.



As represented above, the Plain Compass has a needle six inches long, a graduated circle, main plate, levels and sights, and is placed upon the brass head of the "Jacob staff."

THE COMPASS CIRCLE in this, as in all our instruments, is divided to half degrees on its upper surface, the whole degree marks being also cut down on the inside circumference, and is figured from 0 to 90, on each side of the centre or "line of zeros."

The circle and face of the compass are silvered.

THE SPIRIT LEVELS are placed at right angles to each other so as to level the plate in all directions, and are balanced upon a pivot underneath the middle of the tube, so as to be adjustable by a common screw-driver.

THE SIGHTS, or standards, have fine slits cut through nearly their whole length, terminated at intervals by large circular apertures, through which the object sighted upon is more readily found. Sometimes a fine horse-hair or wire is substituted for one half the slit, and placed alternately with it on opposite sights.

TANGENT SCALE.—The right and left hand edges of the sights of our compasses, have respectively an eye-piece, and a series of divisions, by which angles of elevation and depression, for a range of about twenty degrees each way, can be taken with considerable accuracy.

Such an arrangement is very properly termed a "tangent scale," the divided edges of the north sight, being tangents to segments of circles having their centres at the eye-pieces, and their points of contact with the tangent lines at the zero divisions of the scale.

The cut shows the eye-piece and divisions for angles of depression; those for angles of elevation, concealed in this cut, are seen in that of the Railroad Compass.

THE JACOB STAFF mountings which are furnished with all our compasses, and packed in the same case, consist of the brass head already mentioned, and an iron ferule or shoe, pointed with steel, so as to be set firmly in the ground.

The staff, to which the mountings should be securely fastened, is procured from any wheelwright, or selected by the surveyor himself from a sapling of the forest.

#### *To adjust the Compass.*

THE LEVELS.—First bring the bubbles into the centre, by the pressure of the hand on different parts of the plate, and then turn the compass half way around; should the bubbles run to the end of the tubes, it would indicate that those ends were the highest; lower them by tightening the screws immediately under, and loosening those under the lowest ends until, by estimation, the error is half removed; level the plate again, and repeat the first operation until the bubbles will remain in the center, during an entire revolution of the compass.

THE SIGHTS may next be tested by observing through the slits a fine hair or thread, made exactly vertical by a plumb. Should the hair appear on one side of the slit, the sight must be adjusted by filing off its under surface on that side which seems the highest.

THE NEEDLE is adjusted in the following manner: Having the eye nearly in the same plane with the graduated rim of

the compass circle, with a small splinter of wood or a slender iron wire, bring one end of the needle in line with any prominent division of the circle, as the zero, or ninety degree mark, and notice if the other end corresponds with the degree on the opposite side ; if it does, the needle is said to "cut" opposite degrees ; if not, bend the centre-pin by applying a small brass wrench, furnished with our compasses, about one eighth of an inch below the point of the pin, until the ends of the needle are brought into line with the opposite degrees.

Then holding the needle in the same position, turn the compass half way around, and note whether it now cuts opposite degrees ; if not, correct half the error by bending the needle, and the remainder by bending the centre-pin.

The operation should be repeated until perfect reversion is secured in the first position.

This being obtained, it may be tried on another quarter of the circle ; if any error is there manifested, the correction must be made in the centre-pin only, the needle being already straightened by the previous operation.

When again made to cut, it should be tried on the other quarters of the circle, and corrections made in the same manner until the error is entirely removed, and the needle will reverse in every point of the divided surface.

#### *To use the Compass.*

In using the compass the surveyor should keep the south end towards his person, and read the bearings from the north end of the needle. He will observe that the E and W letters on the face of the compass are reversed from their natural position, in order that the direction of the line of sight may be correctly read.

The compass circle being graduated to half degrees, a little practice will enable the surveyor to read the bearings to quarters, or even finer—estimating with his eye the space bisected by the point of the needle, and as this is as low as the traverse table is usually calculated, it is the general practice.

Sometimes, however, a small vernier is placed upon the south end of the needle, and reads the circle to five minutes of a degree—the circle being in that case graduated to whole degrees.

This contrivance, however, is quite objectionable on account of the additional weight imposed on the centre-pin,

and the difficulty of reading a vernier which is in constant vibration, and is therefore but little used.

**TO TAKE ANGLES OF ELEVATION.**—Having first leveled the compass, bring the south end towards you, and place the eye at the little button, or eye piece, on the right side of the south sight, and with the hand fix a card on the front surface of the north sight, so that its top edge will be at right angles to the divided edge, and coincide with the zero mark; then sighting over the top of the card, note upon a flagstaff the height cut by the line of sight; then move the staff up the elevation, and carry the card along the sight until the line of sight again cuts the same height on the staff, read off the degrees and half degrees passed over by the card, and we shall have the angle required.

**FOR ANGLES OF DEPRESSION.**—Proceed in the same manner, using the eye-piece and divisions on the opposite sides of the sights, and reading from the top of the standards.

**JACOB STAFF SOCKET.**—The compass is furnished with a ball spindle, or socket, upon which it turns, and by which it is levelled. The ball may be placed in a single or "jacob staff" socket, as represented in the figure, or in a compass tripod, such as is shown in the cut of the Vernier Transit beyond.

**CLAMP SCREW.**—In the side of the hollow cylinder, or socket of the compass, which fits to the ball spindle, is a screw by which the instrument may be clamped to the spindle in any position.

**SPRING CATCH.**—Besides the clamp screw, we have recently fitted to the sockets of our compasses a little spring catch, which, as soon as the instrument is set upon the spindle, slips into a groove, and thus removes all danger of falling when the instrument is carried.

**NEEDLE LIFTER.**—There is also underneath the main plate, a needle lifting screw which, by moving a concealed spring, raises the needle from the pivot, and thus prevents the blunting of the point in transportation.

When the compass is not in use it is the practice of many surveyors to let down the needle upon the point of the centre-pin, and let it assume its position in the magnetic meridian, so as to retain or even increase its polarity.

We would advise in addition, that after the needle has settled it should be raised against the glass, in order not to dull the point of suspension.

**OUTREPER.**—A small dial plate, having an index turned by

a milled head underneath, is often used with this and the other compasses to keep tally in chaining.

The dial is figured from 0 to 16, the index being moved one notch for every chain run.

**ELECTRICITY.**—A little caution is necessary in handling the compass, that the glass covering be not excited by the friction of cloth, silk, or the hand, so as to attract the needle to its under surface.

A brass cover is sometimes fitted over the glass of the compass, and serves to protect it from accident, as well as to prevent electric disturbance.

When, however, the glass becomes electric, the fluid may be removed by breathing upon it, or touching different parts of its surface with the moistened finger.

An ignorance of this apparently trifling matter has caused many errors and perplexities in the practice of the inexperienced surveyor.

#### *Repairs of the Compass.*

To enable the surveyor to make such repairs as are possible without having recourse to an instrument maker, we here add a few simple directions.

1. **THE NEEDLE.**—It may sometimes happen that the needle has lost its polarity, and needs to be re-magnetized; this is effected in the following manner:

The operator being provided with an ordinary permanent magnet,\* and holding it before him, should pass with a gentle pressure each end of the needle from centre to extremity over the magnetic pole, describing before each pass a circle of about six inches radius, to which the surface of the pole is tangent, drawing the needle towards him, and taking care that the north and the south ends are applied to the *opposite* poles of the magnet.

Should the needle be returned in a path near the magnetic pole, the current induced by the contact of the needle and magnet, in the pass just described, would be reversed, and thus the magnetic virtue almost entirely neutralized at each operation.

When the needle has been passed about twenty-five times in succession, in the manner just described, it may be considered as fully charged.

A fine brass wire is wound in two or three coils on the south end of the needle, and may be moved back or forth in order to counterpoise the varying weight of the north end.

2. **THE CENTRE PIN.**—This should occasionally be examined,

\* A magnet suitable for this purpose costs from 25 to 50 cents.



and if much dulled, taken out with the brass wrench, already spoken of, or with a pair of plyers, and sharpened on a hard oil stone—the operator placing it in the end of a small stem of wood, or a pin vice, and delicately twirling it with the fingers as he moves it back and forth at an angle of about 30 deg. to the surface of the stone.

When the point is thus made so fine and sharp as to be invisible to the eye, it should be smoothed by rubbing it on the surface of a soft and clean piece of leather.

3. TO PUT IN A NEW GLASS.—Unscrew the “bezzle ring” which holds it, and with the point of a knife blade spring out the little brass ring above the glass, remove the old glass and scrape out the putty; then if the new glass does not fit, smooth off its edges by holding it obliquely on the surface of a grind stone until it will enter the ring easily; then put in new putty, spring in the brass ring, and the operation will be complete.

4. TO REPLACE A SPIRIT LEVEL.—Take out the screws which hold it on the plate, pull off the brass ends of the tube, and with a knife blade scrape out the plaster from the tube; then with a stick made a little smaller than the diameter of the tube, and with its end hollowed out, so that it will bear only on the broad surface of the level vial, push out the old vial and replace it with a new one, taking care that the crowning side, which is usually marked with a file on the end of the vial, is placed on the upper side.

When the vial does not fit the tube it must be wedged up by putting under little slips of paper until it moves in snugly.

After the vial is in its place, put around its ends a little boiled plaster, mixed with water to the consistency of putty, taking care not to allow any to cover the little tip of the glass, then slip in the brass ends and the operation will be completed.

A little beeswax, melted and dropped upon the ends of the vial, is equally as good as the boiled plaster, and often more easily obtained.

We would here remark that an extra glass and level vials are always furnished, free of charge, with our instruments, whenever desired by the purchaser.

#### *Sizes of the Plain Compass.*

Three different sizes of this instrument are in common use, having respectively four, five and six-inch needles, and differing also in the length of the main plate, which in the four

inch compass is twelve and a half inches long, and in the larger sizes, fifteen and a half inches.

The six-inch needle compass is generally preferred.

*Weight of the Plain Compasses.*

The average weights of the different sizes, with the brass mountings of the jacob staff, are :

For the 4-inch needle, 6 lbs.

For the 5-inch needle, 7½ lbs.

For the 6-inch needle, 8½ lbs.

The plain compass, which was the only one in use in this country previous to the time of David Rittenhouse, has gradually given way to the superior advantages of the Vernier or Rittenhouse compass, which we shall now proceed to describe.

---

THE VERNIER COMPASS.

No. 375.

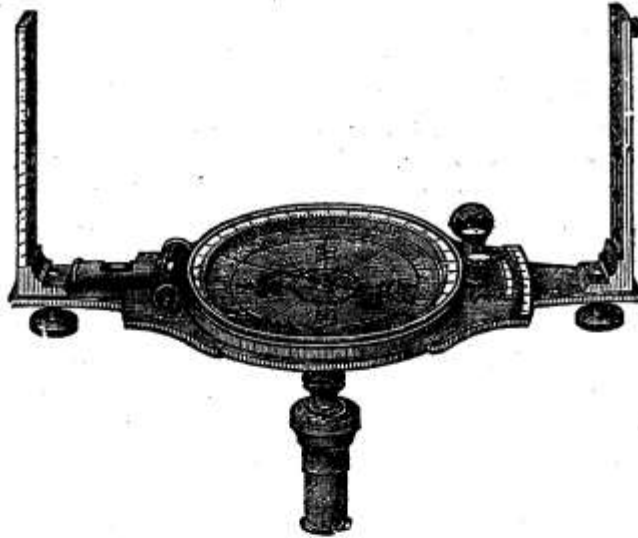

The vernier compass, represented in No. 375, differs from the instrument just described, in having its compass circle, with a vernier attached, moveable about a common centre by turning the "tangent screw," seen at the south end of the plate.

Sometimes a rack and pinion movement is substituted for the tangent screw, and is desirable where frequent changes of the vernier are required. It makes no difference in the price of the compass.

The superiority of the vernier over the plain compass con-



sists in its adaptation to the retracing the lines of an old survey, and to the surveys of the U. S. public lands, where the lines are based on a true meridian.

*Variation of the Needle.*

It is well known that the magnetic needle, in almost all parts of the United States, points more or less to the east or west of a true meridian, or north and south line.

This deviation, which is called the VARIATION OR DECLINATION of the needle, is not constant, but increases or decreases to a very sensible amount in a series of years.

Thus at Troy, N. Y., a line bearing in 1830, N. 31° E., would now, 1862, with the same needle, have a bearing of about N. 32° E., the needle having thus in that interval travelled a full degree to the west.

For this reason, therefore, in running over the lines of a farm from field notes of some years standing, the surveyor would be obliged to make an allowance, both perplexing and uncertain, in the bearing of every line.

To avoid this difficulty the *vernier* was devised, the arrangement of which we shall now describe.

THE VERNIER is divided on its edge to thirty equal parts, and figured in two series on each side of the centre line.

In the same plane with the vernier is an arc or limb, fixed to the main plate of the compass, and graduated to half degrees.

The surfaces of both vernier and limb are silvered.

On the vernier are thirty equal divisions, which exactly correspond in length with thirty-one of the half degrees of the limb.

Each division of the vernier is, therefore, one-thirtieth or, in other words, one minute longer than a single division of the limb.

TO READ THE VERNIER.—In "reading" the vernier, if it is moved to the right, count the minutes from its zero point to the left, and vice versa. Proceed thus until a division on the vernier is found exactly in line with another on the limb, and the lower row of figures on the vernier will give the number of minutes passed over. When the vernier is moved more than fifteen minutes to either side the number of the additional minutes up to thirty or one-half degree of the limb is given by the upper row of figures on the opposite side of the vernier.

To read beyond thirty, add the minutes given by the vernier to that number, and the sum will be the correct reading.

In all cases when the zero point of the vernier passes a whole degree of the limb, this must be added to the minutes, in order to define the distance over which the vernier has been moved.

**TO TURN OFF THE VARIATION.**—It will now be seen that the surveyor having the vernier compass, can by moving the vernier to either side, and with it of course the compass circle attached, set the compass to any variation.

He therefore places his instrument on some well defined line of the old survey, and turns the tangent screw until the needle of his compass indicates the same bearing as that given in the old field notes of the original survey.

Then screwing up the clamping nut underneath the vernier, he can run all the other lines from the old field notes without further alteration.

The reading of the vernier on the limb in such a case would give the change of variation at the two different periods.

The variation of the needle at any place being known, a true meridian, or north and south line, may be run by moving the vernier to either side, as the variation is east or west, until the arc passed over on the limb is equal to the angle of variation; and then turning the compass until the needle is made to cut the zeros on the divided circle, when the line of the sights would give the direction of the true meridian of the place.

Such a change in the position of the vernier is necessary in surveying the U. S. public lands, which are always run from the true meridian.

"THE LINE OF NO VARIATION, as it is called, or that upon which the needle will indicate a true north and south direction, is situated in the United States, nearly in an imaginary line drawn from the middle of lake Erie to Cape Hatteras, on the coast of North Carolina.

A compass needle, therefore, placed east of this line would have a variation to the west, and when placed west of the line, the variation would be to the east, and in both cases the variation would increase as the needle was carried farther from the line of no variation.

Thus in Minnesota the variation is from  $15^{\circ}$  to  $16^{\circ}$  to the east, while in Maine it is from  $17^{\circ}$  to  $18^{\circ}$  to the west.

At Troy, in the present year, 1862, the variation is about  $8^{\circ}$  to the west, and is increasing in the same direction from two to three minutes annually.

**TO READ TO MINUTES.**—A less important use of the vernier

is to give a reading of the needle to single minutes, which is obtained as follows:

First be sure, as in all observations, that the zero of the vernier exactly corresponds with that of the limb; then noting the number of whole degrees given by the needle, move back the compass circle with the tangent screw until the nearest whole degree mark is made to coincide with the point of the needle, read the vernier as before described, and this reading added to the whole degrees will give the bearing to minutes.

*To use the Vernier Compass.*

Proceed in the same manner as directed in regard to the Plain Compass, when making new surveys, always taking care that the vernier is set at zero and securely clamped by screwing up the nut beneath the plate.

In surveying old farms, allowance and correction must be made for the variation, as just described.

*Sizes of the Vernier Compass.*

We make but one size of this instrument, having a six-inch needle and a main plate fifteen and a half inches long.

*Weight of the Vernier Compass.*

The average weight of this instrument, with the jacob staff mountings, is about  $9\frac{1}{2}$  pounds.

THE ADJUSTMENTS of the Vernier Compass are mainly those of the instrument first described, and need not here be repeated.

## Surveying Instruments.

---

### THE VERNIER TRANSIT.

No. 378.



The Vernier Transit, or Transit Compass, represented in the cut above, has the same general properties as the Vernier Compass, but is furnished with a telescope in place of the ordinary sights.

The telescope is from ten to twelve inches long, and sufficiently powerful to see and set a flag at a distance of two miles in a clear day.

The cross-bar in which it is fixed, turns readily in the standards, so that the telescope can be turned in either direction, and back and fore sights be taken without removing the instrument.

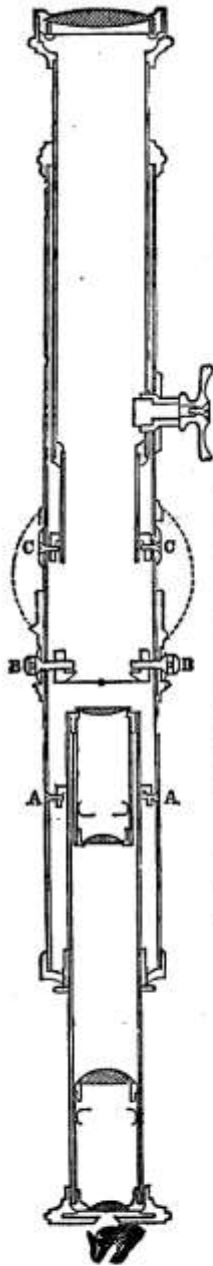

Fig. A.

Like all telescopes used by us in our instruments, it shows objects in an erect position.

**THE TELESCOPE.**—The interior construction of the telescope of the Vernier Transit, which is very similar to those of the other instruments we shall describe, is well shown in the longitudinal section represented in fig. *a*.

As here seen, the telescope consists essentially of an object-glass, an eye-piece tube, and a cross-wire ring or diaphragm.

The object-glass is composed of two lenses, one of flint, the other of crown glass, which are so made and disposed as to show the object seen through it without color or distortion.

The object-glass and the whole telescope is therefore said to be "achromatic."

The eye-piece is made up of four plano-convex lenses, which, beginning at the eye end, and proceeding on, are called respectively, the eye, the field, the amplifying, and the object lenses.

Together, they form a compound microscope, magnifying the minute image of any object formed at the cross-wires by the interposition of the object-glass.

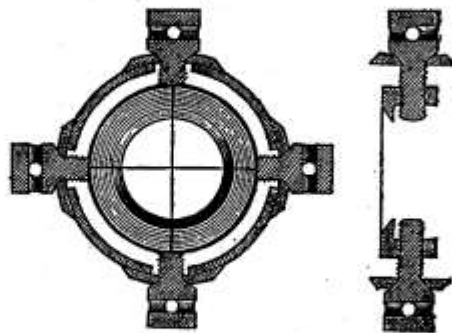

Fig. B.

**THE CROSS WIRES.**—The cross-wire diaphragm, two views of which are here exhibited, is a small ring of brass, suspended in the tube of the telescope by four capstan head screws, which press upon the washers shown on the outside of the tube.

The ring can thus be moved in either direction by working the screws with an ordinary adjusting pin.

Across the flat surface of the ring two fine fibres of spider's web are extended at right angles to each other, their ends being cemented with beeswax or varnish, into fine lines cut in the metal of the ring.

The intersection of the wires forms a very minute point, which, when they are adjusted, determines the optical axis of the telescope, and enables the surveyor to fix it upon an object with the greatest precision.

The imaginary line passing through the optical axis of the telescope, is termed the "line of collimation," and the operation of bringing the intersection of the wires into the optical axis, is called the "adjustment of the line of collimation." This will be hereafter described.

The openings in the telescope tube are made considerably larger than the screws, so that when these are loosened, the whole ring can be turned around for a short distance in either direction.

The object of this will be seen more plainly, when we describe the means by which the wire is made truly vertical.

The sectional view of the telescope (fig. A) also shows two moveable rings, one placed at A A, the other at C C, which are respectively used, to effect the centering of the eye-piece, and the adjustment of the object-glass slide.

The centering of the eye-tube is performed after the wires have been adjusted, and is effected by moving the ring, by means of the screws, shown on the outside of the tube, until the intersection of the wires is brought into the centre of the field of view.

The adjustment of the object slide, which will be fully described in our account of the Leveling Instrument, secures the movement of the object-glass in a straight line, and thus keeps the line of collimation in adjustment through the whole range of the slide, preventing at the same time what is termed the "travelling" of the wires.

This adjustment, which is peculiar to our telescopes, is always made in the process of construction, and needing no further attention at the hands of the engineer, is concealed within the hollow ball of the telescope axis.

*Optical Principles of the Telescope.*

In order that the advantages gained by the use of the telescope may be more fully understood, we shall here venture briefly to consider the optical principles involved in its construction.

We are said to "see" objects because the rays of light which proceed from all their parts, after passing through the pupil of the eye, are by the crystalline lens and vitreous humor, converged to a focus on the retina, where they form a very minute inverted image; an impression of which is conveyed to the brain by the optic nerve.

The rays proceeding from the extremities of an object, and crossing at the optic center of the eye, form the "visual angle," or that under which the object is seen.

The apparent magnitude of objects depends on the size of the visual angle which they subtend, and this being great or small, as the object is near or distant—the objects will appear large or small, in an inverse proportion to the distances which separate them from the observer.

Fig. C.

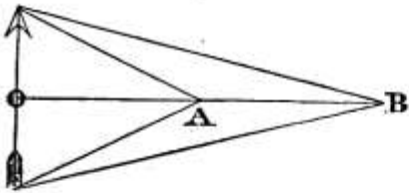

Thus, (in fig. C,) if the distance O A is one-half of O B, the visual angle, subtended by the object at the point A, and therefore the apparent magnitude of the object will

be twice that observed at B. If, therefore, the visual angle subtended by any object, can be made by any means twice as large, the same effect will be produced as if the observer were moved up over one half the intervening distance.

Now this is the principal advantage gained in the use of a telescope.

The object-glass receiving the rays of light which proceed from all the points of a visible object, converges them to a focus at the cross-wires, and there forms a minute, inverted, and very bright image, which may be seen by placing a piece of ground glass to receive it at that point.

The eye-piece acting as a compound microscope, magnifies this image, restores it to its natural position, and conveys it to the eye.

The visual angle which the image there subtends, is as many times greater than that which would be formed without the use of the telescope, as the number which expresses its magnifying power.





Fig. D.

Thus, a telescope which magnifies twenty times, increases the visual angle just as much, and therefore diminishes the apparent distance of the object twenty times—or in other words, it will show an object two hundred feet distant, with the same distinctness as if it was distant only ten feet from the naked eye.

The accompanying cut, (fig. D) which we are kindly permitted to copy from an excellent treatise on surveying, by Prof. Gillespie of Union College, will give a correct idea of the manner in which the rays of light coming from an object are affected, by passing through the several glasses of a telescope.

We shall only consider the rays which proceed from the extremities; these, after passing through the object-glass, here shown as a single lens, are conveyed to the point B, the centre of the cross-wires and the common focus of the object and eye-glasses. At this place the rays cross each other and the image is inverted.

The rays next come to the object lens C, and passing through it are refracted so as again to cross each other, and come thus to the amplifying lens D. By this they are again refracted, made more nearly parallel, and thus reach the large field lens E. After passing through this, they form a magnified and erect image in the focus of the eye lens G. By the eye lens the image is still further magnified, and at last enters the eye of the observer, subtending an angle as much greater than that at the point O, as is the magnifying power of the telescope.

In place of the eye-piece of four lenses, which we have just been considering, and which is exclusively used in all American instruments made at the present day; another, which has but three lenses, is often seen in the telescopes of imported instruments.

This latter, which inverts the object, though saving a little more light than the former, is exceedingly troublesome to the inexperienced observer, and has never been popular in American engineering.



*To ascertain the Magnifying Power of a Telescope.*

Set up the instrument about twenty or thirty feet from the side of a white wooden house, and observe through the telescope the space covered by one of the boards in the field of the glass; then still keeping that eye on the telescope, hold open the other with the finger, if necessary, and look with it at the same object. By steady and careful observation there will appear on the surface of the magnified board, a number of smaller ones seen by the naked eye, count these, and we shall obtain the magnifying power.

If the limits of the magnified board, as seen through the telescope, can be noted so as to be remembered after the eye is removed, the number of boards contained in this space may then be easily counted.

The side of an unpainted brick wall, or any other surface containing a number of small, well marked and equal objects, may be observed, in place of the surface we have described.

The operation described requires great care and close observation, but may be performed with facility after a little practice.

We have spoken of the effect of the telescope in magnifying objects, but have not mentioned what is termed its "illuminating power."

This arises from the great diameter or aperture of the object-glass compared with that of the pupil of the eye, which enables the observer to intercept many more rays of light, and bring the object to the eye highly illuminated.

The advantage gained in this increase of light, depends, as is evident, on the size of the object glass, and the perfection with which the lenses transmit the light without absorbing or reflecting it.

The superficial magnifying power of a telescope, is found by squaring the number which expresses its linear magnifying power; thus a telescope which magnifies twenty times, increases the surface of an object four hundred times.

Before an observation is made with the telescope, the eyepiece should be moved in or out, until the wires appear distinct to the eye of the operator; the object-glass is then adjusted by turning the pinion head until the object is seen clear and well defined, and the wires appear as if fastened to its surface.

The intersection of the wires, being the means by which the optical axis of the telescope is defined, should be brought

precisely upon the centre of the object to which the instrument is directed.

Having thus briefly considered the principles, we shall now proceed to describe the

*Attachments of the Telescope.*

A telescope is said to be "plain" when it is without any appendages to its tube or axis, as that of the Engineer's Transit shown in the engraving, and most instruments are made in that manner.

Many surveyors, however, prefer to add these conveniences, and we shall now consider them in detail.

**CLAMP AND TANGENT.**—This consists essentially of a ring, encircling the axis of the telescope, and having two projecting arms, the one above being slit through the middle and holding the clamp screw, the other much longer and below, is connected with the tangent screw.

As soon as the clamp screw is tightened, the ring is brought firmly around the axis, and the telescope can then be moved up or down by turning the tangent screw.

The clamp and tangent ought always to accompany the vertical circle, and the level on the telescope.

**VERTICAL CIRCLE.**—A divided circle as seen in the cut of the Vernier Transit, is often attached to the axis of the telescope, giving, with a vernier, the means of measuring vertical angles with great facility.

We make two sizes of these circles, one of about  $3\frac{1}{2}$  inches diameter, seen with this instrument, the other an inch larger, and shown in the cut of the Surveyor's Transit. The former is graduated to single degrees, and reads by the vernier, to five minutes of a degree. The latter, divided to half degrees, gives a reading, with the vernier, to single minutes.

The vertical circle is fitted firmly to the telescope axis, and fastened with a screw, so that it remains permanent.

The vernier, however, may be shifted in either direction, by loosening the screws which confine it to the standards.

The vernier of the small circle is divided into twelve equal parts, which correspond with thirteen degrees on the circle.

Each division of the vernier is, therefore, one-twelfth of one degree, or five minutes longer than a single division of the circle, so that the angles are read to five minutes of a degree.

The vernier is double, having its zero point in the middle, and the reading up to thirty minutes, is said to be direct; that is, if the circle is moved to the right, the minutes are read off on the right side of the vernier, and vice versa.

The minutes beyond thirty are obtained on the opposite side, and in the lower row of figures.

By following these directions, and noticing the first divisions on the circle and vernier, which exactly correspond, the surveyor can obtain a reading to five minutes with great facility.

**LEVEL ON TELESCOPE.**—Besides the vertical circle, there is sometimes a small level attached to the telescope of this and other instruments, which we shall hereafter describe.

Such an attachment is shown in the cut of the Surveyor's Transit, and its adjustment and advantages will be explained in our account of that instrument.

**SIGHTS ON TELESCOPE.**—We are sometimes desired by surveyors to place a pair of short sights on the upper side of the telescope tube.

They are best made to fold close to the tube when not in use, like those of the pocket compass, described hereafter.

These sights are useful in taking back sights without turning the telescope, and in sighting through bushes or in the forest, and as the telescope can be turned up or down, answer all the purposes of the longer sights of the ordinary compass.

**SIGHTS FOR RIGHT ANGLES.**—Besides the sights just mentioned, we have often attached others to the plate of the instrument, on either side of the compass circle or on the standards.

These being adjusted to the telescope give a very ready means of laying off right angles, or running out offsets, without changing the position of the instrument.

*To adjust the Vernier Transit.*

**THE LEVELS** of this instrument have a capstan head screw at each end, and are adjusted with a steel pin in the same manner as those of the Plain compass.

**THE NEEDLE** is also adjusted as described in our account of that instrument.

**LINE OF COLLIMATION.**—To make this adjustment, which is, in other words, to bring the intersection of the wires into the optical axis of the telescope, so that the instrument, when placed in the middle of a straight line will, by the revolution of the telescope, cut its extremities—proceed as follows:

Set the instrument firmly on the ground and level it carefully; and then having brought the wires into the focus of the eye-piece, adjust the object-glass on some well defined

point, as the edge of a chimney or other object, at a distance of from two to five hundred feet; determine if the vertical wire is plumb, by clamping the instrument firmly to the spindle and applying the wire to the vertical edge of a building, or observing if it will move parallel to a point taken a little to one side; should any deviation be manifested, loosen the cross-wire screws, and by the pressure of the hand on the head outside the tube, move the ring around until the error is corrected.

The wires being thus made respectively horizontal and vertical, fix their point of intersection on the object selected; clamp the instrument to the spindle, and having revolved the telescope, find or place some good object in the opposite direction, and at about the same distance from the instrument as the first object assumed.

Great care should always be taken in turning the telescope, that the position of the instrument upon the spindle is not in the slightest degree disturbed.

Now, having found or placed an object which the vertical wire bisects, unclamp the instrument, turn it half way around, and direct the telescope to the first object selected; having bisected this with the wires, again clamp the instrument, revolve the telescope, and note if the vertical wire bisects the second object observed.

Should this happen, it will indicate that the wires are in adjustment, and the points bisected are with the centre of the instrument, in the same straight line.

If not, however, the space which separates the wires from the second point observed, will be double the deviation of that point from a true straight line, which may be conceived as drawn through the first point and the centre of the instrument, since the error is the result of two observations, made with the wires when they are out of the optical axis of the telescope.

Fig. E.

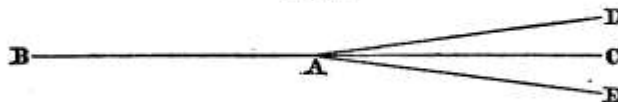

For as in the diagram, let A represent the centre of the instrument, and B C the imaginary straight line, upon the extremities of which the line of collimation is to be adjusted.

B represents the object first selected, and D the point which the wires bisected, when the telescope was made to revolve.

When the instrument is turned half around, and the telescope again directed to B, and once more revolved, the wires

will bisect an object, E, situated as far to one side of the true line as the point D is on the other side.

The space, D E, is therefore the sum of two deviations of the wires from a true straight line, and the error is made very apparent.

In order to correct it, use the two capstan head screws on the sides of the telescope, these being the ones which affect the position of the vertical wire.

Remember that the eye-piece inverts the position of the wires, and therefore that in loosening one of the screws and tightening the other on the opposite side, the operator must proceed as if to increase the error observed. Having in this manner moved back the vertical wire until, by estimation, one-quarter of the space, D E, has been passed over, return the instrument to the point B, revolve the telescope, and if the correction has been carefully made, the wires will now bisect a point, C, situated midway between D and E, and in the prolongation of the imaginary line, passing through the point B and the centre of the instrument.

To ascertain if such is the case, turn the instrument half around, fix the telescope upon B, clamp to the spindle, and again revolve the telescope towards C. If the wires again bisect it, it will prove that they are in adjustment, and that the points, B, A, C, all lie in the same straight line.

Should the vertical wire strike to one side of C, the error must be corrected precisely as above described, until it is entirely removed.

Another method of adjusting the line of collimation often employed in situations where no good points in opposite directions can be selected upon which to reverse the wires, may here be described.

The operator sets up the instrument in some position which commands a long sight in the same direction, and having leveled his instrument, clamps to the spindle, and with the telescope locates three points which we will term A, B and C, which are distant from the instrument about one, two and three hundred feet respectively.

These points, which are usually determined by driving a nail into a wooden stake set firmly into the ground, will all lie in the same straight line, however much the wires are out of adjustment, since the position of the instrument remains unchanged during the whole operation.

Having fixed these points he now moves the instrument to B, and sets its centre directly over the nail head, by letting down upon it the point of a plumb-bob suspended from the tripod

Then having leveled the instrument, he directs the wires to A, clamps to the spindle and revolves the telescope towards C. Should the wires strike the nail at that point, it would show that they were in adjustment.

Should any deviation be observed, the operator must correct it by moving the wire with the screws until, by estimation, half the error is removed.

Then bringing the telescope again upon either A or C, and revolving it, he will find that the wires will strike the point in the opposite direction if the proper correction has been applied.

If not, repeat the operation until the telescope will exactly cut the two opposite points, when the intersection of the wires will be in the optical axis, and the line of collimation in adjustment.

In our description of the previous operation, we have spoken more particularly of the vertical wire, because in a revolving telescope this occupies the most important place, the horizontal one being employed mainly to define the centre of the vertical wire, so that it may be moved either up or down without materially disturbing the line of collimation.

The wires being adjusted, their intersection may now be brought into the centre of the field of view.

THE EYE-PIECE is centered by moving the screws A A, shown in the sectional view of the telescope, Fig. *a*, which are slackened and tightened in pairs, the movement being now direct, until the wires are seen in their proper position.

It is here proper to observe, that the position of the line of collimation depends upon that of the object-glass, solely, so that the eye-piece may, as in the case just described, be moved in any direction, or even entirely removed and a new one substituted, without at all deranging the adjustment of the wires.

THE STANDARDS.—In order that the wires may trace a vertical line as the telescope is moved up or down, it is necessary that both the standards of the telescope should be of precisely the same height.

To ascertain this and make the correction if needed, proceed as follows:

Having the line of collimation previously adjusted, set the instrument in a position where points of observation, such as the point and base of a lofty spire, can be selected, giving a long range in a vertical direction.

Level the instrument, fix the wires on the top of the object and clamp to the spindle, then bring the telescope down,



until the wires bisect some good point, either found or marked at the base; turn the instrument half around, fix the wires on the lower point, clamp to the spindle, and raise the telescope to the highest object.

If the wires bisect it, the vertical adjustment is effected; if they are thrown to either side this would prove that the standard opposite that side was the highest, the apparent error being double that actually due to this cause

To correct it, we now make one of the bearings of the axis movable, so that by turning a screw underneath this sliding piece, as well as the screws which hold on the cap of the standard, the adjustment is made with the utmost precision.

This arrangement, which is common to all our telescope instruments, is very substantial and easily managed

**THE VERTICAL CIRCLE.**—When this attachment requires adjustment, proceed by leveling the instrument carefully, and having brought into line the zeros of the wheel and vernier, find or place some well defined point or line which is cut by the horizontal wire.

Turn the instrument half around, revolve the telescope, and fixing the wire upon the same point as before, note if the zeros are again in line.

If not, loosen the screws and move the zero of the vernier over half the error; bring the zeros again into coincidence, and proceed precisely as at first described until the error is entirely corrected, when the adjustment will be completed.

Should it be desired, at any time, the circle can be removed by the surveyor and replaced at pleasure.

**THE LEVEL ON TELESCOPE.**—The adjustment of this will be best considered when we come to speak of the Surveyors' Transit.

**ADJUSTMENTS IN GENERAL.**—We ought here to say that the above adjustments, as well as all the others which we have previously explained or may hereafter describe, are always made by us in person, but are given in this work in order that the surveyor and engineer may fully understand their instruments, and be enabled to detect and remedy errors and accidents, which in practice will often occur.

*To use the Vernier Transit.*

This instrument is used on the ordinary ball and spindle, placed most commonly in the compass tripod, as shown in Fig. 378.

**TRIPOD HEAD.**—Sometimes leveling screws with the parallel plates, and which together we shall designate the "tripod head," with a clamp and tangent movement, are used with this instrument as well as with the Surveyors' Transit.



This tripod head can be unscrewed from the legs, and is packed in the instrument box; it is of very moderate cost, and in almost every situation is infinitely superior to a ball and socket support.



[No. 393.]

COMPOUND BALL.—We also manufacture what may be termed a “compound ball spindle,” which has a tangent movement, and gives all the perfection of more costly arrangements, with a very moderate expense.

As represented in the cut, it has an interior spindle, around which an outside hollow cylinder is moved by turning the double-headed tangent screw, which has in the middle an endless screw, working into teeth cut spirally around in a groove of the cylinder. The compass, or other instrument, revolves on the outside socket, precisely as if placed on a common ball spindle; but when a slower movement is required, can be made fast by the clamp screw, and then turned gradually around the interior spindle by the tangent screw, until the slote of the sight or the intersection of the wires, is made to bisect the object with the utmost certainty.

The compound ball may be placed either in a jacob-staff socket or compass tripod.

LEVELING SOCKET.—A very beautiful arrangement for use, either with this instrument or with a sight compass, is shown in the leveling socket described in our account of the solar compass beyond.

The socket may be used either with the ordinary compass ball or the compound ball, as there represented, and gives a very rapid and accurate means of leveling the instrument.

THE SPRING CATCH, described in our account of the Plain Compass, is always attached to the socket of this instrument, whether placed upon a ball or tripod, so that it cannot slip off from the spindle in carrying.

THE CLAMP SCREW in the side of the socket of this instrument, is shown in No. 377, and by pressing a brass spring in the interior against the spindle, serves to fix the instrument in any position.

THE VERNIER is moved by the tangent screw, now always placed above the plate, precisely as described in our account of the Vernier Compass, and is read to minutes in the same manner.

There is also a clamp nut underneath the vernier, by which it is securely fixed in any position, which must be loosened whenever the vernier is moved by the tangent screw.

THE NEEDLE LIFTING SCREW is the same as those of the compasses previously described.

IN SURVEYING with this instrument the operator proceeds precisely as with the Vernier Compass, keeping the south end towards his person, reading the bearings of lines from the north end of the needle, and using the telescope in place of sights, revolving it as objects are selected in opposite directions.

PARALLAX.—Before an observation is made with the telescope, the eye-piece should be moved in or out until the wires appear distinct to the eye of the operator, the object-glass may then be placed in position by turning the pinion head on the top of the telescope, until the object is seen clear and well defined, and the wires appear as if fastened to its surface.

When, on the contrary, the wires are not perfectly distinct, the observer, by moving his eye to either side of the small aperture of the eye piece, will cause the wires to "travel" on the object, and thus occasion what is termed the "error of parallax."

The intersection of the wires being the means by which the optical axis of the telescope is defined, should be brought precisely upon the centre of the object to which the instrument is directed.

TO TAKE ANGLES OF ELEVATION.—Level the instrument carefully, fix the zeros of the circle and vernier in line, and note the height cut upon the staff or other object, by the horizontal wire; then carry the staff up the elevation, fix the wire again upon the same point, and the angle of elevation will be read off by the vernier.

By careful usage, the adjustments of the Vernier Transit will remain as permanent as those of the ordinary compass, the only one liable to derangement being that of the line of collimation.

This should be examined occasionally, and corrected in the manner previously described.

*Repairs of the Vernier Transit.*

These being in great part already spoken of, it will be necessary to consider only such as belong to the telescope.

TO REPLACE THE CROSS WIRES.—Take out the eye-piece tube, together with the little ring by which it is centered, and having removed two opposite cross-wire screws, with

the others turn the ring until one of the screw holes is brought into view from the open end of the telescope tube, in this thrust a stout splinter of wood or a small wire so as to hold the ring when the remaining screws are withdrawn; the ring is then taken out and is ready for the wires.

For these the web of the spider is to be preferred above any thing else, but when this is not obtainable, a fine silk fibre may be substituted.

We usually procure our webs from the living manufacturer directly, selecting those of a yellowish-brown color, as furnishing the most perfect product.

The spider being held between the thumb and finger of an assistant, in such position as to suffer no serious injury, and at the same time be unable to make any effectual resistance with his extremities, the little fibre may be drawn out at pleasure, and being placed in the fine lines cut on the surface of the diaphragm, is then firmly cemented to its place by applying softened beeswax with the point of a knife blade.

In case the spider is not procurable, a fine strand of a web which is free from dust, and long enough to serve for both wires, may be selected.

In such times as the spiders remain in their winter quarters, we have been able to procure very good fibres from a box in which a number had been confined.

When the wires are cemented, the ring is returned to its position in the tube, and either pair of screws being inserted, the splinter or wire is removed, and the ring turned until the other screws can be replaced.

Care must also be taken that the same side of the ring is turned to the eye-piece as before it was removed.

When this has been done, the eye-tube is inserted, and its centering ring brought into such a position that the screws in it can be replaced, and then by screwing on the end of the telescope, the little cover into which the eye-tube is fixed, the operation will be completed.

**To CLEAN THE TELESCOPE.**—The only glasses that will ordinarily require cleaning, are the object-glass on its outside surface, and the little eye-lens, which is exposed when the cap of the eye-tube is removed.

To remove the dust from these use a very soft and clean silk or cotton cloth, and be careful not to rub the same part of the cloth a second time on the surface of the glass.

No one should ever be allowed to touch the glasses with the fingers or with a dusty cloth.

*Excellencies of the Vernier Transit.*

These are due chiefly to the telescope and its attachments, and from what has already been said, it will appear are such as to render this instrument greatly superior to one provided with the ordinary sights.

1. The magnifying power of the telescope enables the surveyor to take accurate observations at distances entirely beyond the reach of the naked eye.

2. The fine intersection of the cross-wires can be set precisely upon the centre of the object.

3. The revolving property of the telescope gives the means of running long lines up or down steep ascents or descents with perfect ease, where, with the short sights of the ordinary compass, two or three observations would have to be taken.

4. The use of a telescope entirely avoids the incessant trying of the eyes, experienced in surveys with the ordinary sights.

5. With the telescope, lines can be run through the forest or brushwood, and the flagstaff distinguished with much greater certainty than through the sights of a compass.

This statement may appear very unreasonable to those not familiar with the instrument, and these, in fact, raise the greatest objection to a telescope, from its supposed unfitness for surveys in such locations.

They have only to use it a few times in this kind of work, in connection with a flagstaff, painted white or covered with paper, to distinguish it from the surrounding objects, to be convinced of its great superiority.

In the Vernier Transit, as furnished by us, is supplied, as we believe, to the surveyor the most perfect of all needle instruments, and this at a cost but little above that charged by other makers for a sight compass.

The advantages of the telescope and its attachments are so great that a surveyor, accustomed to them, would find it difficult to content himself with the ordinary compass, and such in fact is the universal testimony of those familiar with the Vernier Transit.

*Weight of the Vernier Transit.*

The weight of this instrument, exclusive of the tripod legs, and with a plain telescope, is about ten pounds.

## Needle Instruments.

---

We have now described the instruments included under the division termed Needle Instruments, in the beginning of this work.

As there stated, the Plain and Vernier Compasses and the Vernier Transit depend for their accuracy and value, mainly upon the perfection of movement of the magnetic needle.

With such instruments, the greater part of the surveying in our country has been, and will for a long time in the future, continue to be done.

And though with the improvements made in these instruments, a good surveyor may, with great care and skill, do work with a surprising degree of accuracy and perfection, yet all needles are liable to many irregularities.

### *Imperfections of the Needle.*

These may arise either from the loss of magnetic virtue in the poles, the blunting of the centre-pin, or the attraction exerted upon it by bodies of iron, whose presence may be entirely unsuspected.

The two first of these errors may be easily remedied in the manner we have described.

**LOCAL ATTRACTION.**—The third and most frequent source of inaccuracy, may be detected by taking back sights, as well as fore sights, upon every line run with the needle, and by the agreement of the bearings, determining the true direction of the line.

Sometimes a compass may have little particles of iron concealed within the surface of the metal circle or plates.

It is the business of the maker to examine every instrument, in search of this defect, by trying the reversion of the needle upon all points of the divided circle.

If the needle should fail to reverse, when the compass is turned half around, and the sights directed a second time upon any object, the instrument should be thrown aside and never sold.

Besides the difficulties caused by the above imperfections, the variation of the needle is a frequent source of annoyance.

What is termed the secular variation, we have already mentioned in our account of the Vernier Compass, we will now speak of the

**DIURNAL VARIATION.**—This is owing to the influence of the sun, which, in summer, will cause the needle to vary from ten to fifteen minutes in a few hours, when exposed to its fullest influence.

To guard against these causes of inaccuracy in the use of needle instruments, the surveyor will need the greatest care and attention ; and yet, with all the precautions than can be suggested, the difficulty of measuring horizontal angles with certainty, and to a sufficient degree of minuteness by the needle alone, has caused a demand to be felt more and more sensibly in all parts of the country for instruments, in the use of which the surveyor may proceed with assured accuracy and precision.

Indeed, in Canada, so great is the distrust of needle instruments, that the Provincial Land Surveyors are forbidden to use an instrument in their land surveys, unless it is capable of taking angles independently of the needle.

To supply the demand thus created for increased perfection in the implements of the surveyor, we manufacture a variety of instruments ; three of which we shall now describe under the names of *The Railroad Compass*, *The Surveyor's Transit*, and the *Solar Compass*.

---

### THE RAILROAD COMPASS.

No. 376.

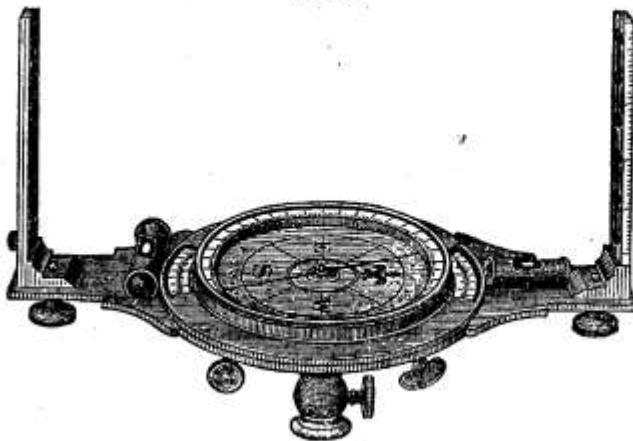

As shown in No. 376, this instrument has the main plate,

levels, sights, and needle of the ordinary instrument, and has also underneath the main plate a divided circle or limb by which horizontal angles to single minutes can be taken independently of the needle.

The verniers are attached to the under surface of the main plate, the openings through which they are seen being covered with slips of glass to protect the divisions from dust and moisture; only one of the verniers is shown in the cut.

The connection between the two plates is made by a clamp and tangent movement shown at *c*, by which they can be fastened together or released at will, or moved slowly around each other as may be desired in the use of the compass.

The needle lifting screw is shown near the clamp screw, on the same end of the plate.

On the opposite side of the compass circle is seen the head *a* of a pinion working into a circular rack fixed to the edge of the compass circle, and thus enabling the surveyor to move the compass circle about its centre in setting off the variation of the needle, precisely as in the case of the vernier compass.

The variation is read to single minutes by a vernier and divided arc, partially shown near the letter *S* in the cut.

Near the pinion head is also shown a clamp screw, by which the circle is securely fixed when moved to the proper position.

The sockets upon which the plates of this instrument turn are long and well fitted, and the movement of the vernier plate around the limb is almost perfectly free from friction.

THE GRADUATED CIRCLE or limb is divided to half degrees, and figured in two rows, viz: from  $0^{\circ}$  to  $90^{\circ}$ , and from  $0^{\circ}$  to  $360^{\circ}$ ; sometimes but a single series is used, and then the figures run from  $0^{\circ}$  to  $360^{\circ}$ , or from  $0^{\circ}$  to  $180^{\circ}$  on each side.

The figuring, which is the same upon this as in the other angular instruments we shall hereafter describe, is varied when desired by the surveyor. The first method is our usual practice.

THE VERNIERS are double, having on each side of the zero mark thirty equal divisions corresponding precisely with twenty-nine half degrees of the limb; they thus read to single minutes, and the number passed over is counted in the same direction in which the vernier is moved.

The use of two opposite verniers in this and other instruments gives the means of "cross questioning" the graduations, the perfection with which they are centered and the dependence which can be placed upon the accuracy of the angles indicated.



THE NEEDLE of this instrument is about five and a half inches long, and made precisely like those previously described.

THE ADJUSTMENTS of this instrument, with which the surveyor will have to do, have been already described.

*To use the Railroad Compass.*

It can be set upon the common compass ball, or still better, the tangent ball already described, placed either in a jacob-staff socket, a compass tripod, or the leveling socket and tripod as shown with the solar compass.

We have also adapted to many of these instruments, the leveling tripod head, with clamp and tangent movement, and this is preferable to any other support.

TO TAKE HORIZONTAL ANGLES.—First level the plate and set the limb at zero, fix the sights upon one of the objects selected, and clamping the whole instrument firmly to the spindle, unclamp the vernier plate and turn it with the hand, until the sights are brought nearly upon the second object; then clamp to the limb, and with the tangent screw fix them precisely upon it.

The number of degrees and minutes read off by the vernier, will give the angle between the two objects, taken from the centre of the instrument.

It will be understood that the horizontal angles can be taken in any position of the verniers, with reference to the zero point of the limb; we have given that above as being the usual method and liable to the fewest errors.

It is advisable where great accuracy is required, in this and other instruments furnished with two verniers, to obtain the readings of the limb from both, add the two together and halve their sum; the result will be the mean of the two readings, and the true angle between the points observed.

Such a course is especially necessary when the readings of the verniers essentially disagree, as may sometimes happen when the instrument has been injured by an accident.

USE OF THE NEEDLE.—In taking horizontal angles as just described, the magnetic bearings of the two objects are often noted, and thus two separate readings of the same angle, one by the limb, the other by the needle, are obtained, to be used as checks upon each other to prevent mistakes.

TO TURN OFF THE VARIATION OF THE NEEDLE.—Having leveled the instrument, set the limb at zero, and place the sights upon the old line, note the reading of the needle, and make it agree with that given in the field notes of the former survey, by turning the compass circle about its centre by the pinion *a*.

Now, clamp the compass circle firmly by the clamp screw, and the number of degrees or minutes passed over by the vernier of the compass circle will be the change of variation in the interval between the two surveys.

To SURVEY with this instrument, the operator should turn the south side of the compass face towards his person, and having brought the zeros of the limb and vernier plate in contact, clamp them, and proceed as directed in our account of the Plain Compass.

Of course it will be understood that lines can be run and angles measured by the divided limb and verniers, entirely independent of the needle, which, in localities where local attraction is manifested, is very serviceable.

The accuracy and minuteness of horizontal angles indicated by this instrument, together with its perfect adaptation to all the purposes to which the Vernier Compass can be applied, have brought it into use in many localities, where the land is so valuable as to require more careful surveys than are practicable with a needle instrument.

*Weight of the Railroad Compass.*

The average weight of this instrument, including the brass head of the jacob staff, is about  $11\frac{1}{2}$  lbs.

### THE SURVEYOR'S TRANSIT.

This instrument shown in the engraving on page 23, is in principle very similar to the instrument just described, differing from it mainly in the substitution of the telescope with its appendages, for the ordinary compass sights.

THE TELESCOPE is of somewhat finer quality than that used with the Vernier Transit; as here shown, it is furnished with a small level, having a ground bubble tube and a scale; and also a vertical circle connected with its axis.

THE STANDARDS are made precisely like those of the Vernier Transit, the bearings of the axis of the telescope being conical, and fitted with the utmost nicety; there is also in one of them the moveable piece for the adjustment of the wires to the tracing of a vertical line.

THE SPIRIT LEVELS are placed upon the upper surface of the vernier plate, one being fixed on the standard so as not to obstruct the light which falls on the vernier opening beneath.

Both levels are adjustable with the ordinary steel pin.

THE NEEDLE is like that of the previous instrument, but is only five inches long.

THE VERNIER PLATE, which carries the verniers and telescopes, is made to move with perfect ease and stability, around the graduated circle or limb, and horizontal angles are taken to single minutes; the variation of the needle is also set off by the pinion and clamp screw, as described in the account of the previous instrument.

THE VERNIERS, as in all our angular instruments, are double, reading either way from the centre mark, and to single minutes of a degree.

There are two verniers, placed on opposite sides of the instrument at right angles to the telescope; only one of these is shown in the cut.

THE DIVIDED CIRCLE, or limb, is graduated to half degrees, reads to minutes by the verniers, and is figured as described before.

THE CLAMP AND TANGENT movement of the vernier plate is the same as that of the Railroad Compass; it is partly shown in the figure.

THE TRIPOD HEAD.—This instrument, as shown in the engraving, is generally used on a leveling tripod.

THE LIGHT LEVELING TRIPOD, used with the Surveyor's Transit, is well shown in the engraving. As there seen, there are nuts screwed in to the upper parallel plate, so as to give a long bearing for the four leveling screws.

The under plate supports the feet of the screws, and has beneath a cavity or bowl, in which moves a hemispherical nut screwed to the spindle of the tripod.

This nut serves both to connect the plates together, and as a pivot on which the upper plate is turned by the leveling screws.

The under parallel plate has also a screw on the under side, by which the tripod head may be disconnected from the legs, and packed in the box with the instrument.

The leveling screws are made of bell metal, have a large double milled head, and a deep screw of about forty threads to the inch; their ends set into little brass cups, so that the screws are worked without indenting the under plate. Sometimes a piece of leather is put in place of the cups.

The leveling screws are entirely covered above by little caps which screw over the upper side of the nut.

When the screws are loosened, the upper plate can be shifted around, so as to bring the leveling screws in any position, with reference to the plates and telescope of the instrument.

The clamp and tangent screws are seen on the upper plate of the tripod. In place of the single tangent screw, we have

in all our instruments, substituted the double tangent movement, as shown in the engraving.

The spindle of the tripod head rises above the upper plate, and the instrument can be removed from it, by pulling out a little pin made to spring into a groove, and thus keep the instrument from falling, when the tripod is carried upon the shoulder.

In the lower end of the spindle and underneath the plates, is screwed the loop for attaching the string of the plumb-bob.

To LEVEL THE TRIPOD, the engineer takes hold of the opposite screw heads with the thumb and fore finger of each hand, and turning both thumbs in or out, as may be necessary, raises one side of the upper parallel plate and depresses the other, until the desired correction is made.

SHIFTING THE TRIPOD HEAD.—A simple arrangement by which an instrument can be easily set over a given point, is made by extending the stem of the tripod head below, through a large circular aperture in the centre of the plate to which the legs are attached, so as to connect by the hemispherical nut or pivot, with a little moveable piece bearing on the under surface of the plate. The leveling screws of course, rest directly on the upper surface of this plate, and when loosened, can be shifted nearly an inch from side to side in any direction; thus allowing the point of the plumb-bob, to be set directly over a given point on the ground.

This modification requires a larger tripod, and gives the surveyor a little more trouble when the tripod head is detached from the legs.

It is not so easily adapted to the Engineer's Transit, as to our other instruments, nor can so much movement be secured, but is made by us for any instrument whenever desired and without additional charge.

ADJUSTING SOCKET, a beautiful arrangement for occasional use in place of the leveling tripod, in cases where greater lightness and rapidity of adjustment are desired, is shown in the adjusting socket, described in the account of the Solar Compass.

*To adjust the Surveyor's Transit.*

THE LEVELS are adjusted with a steel pin as those of the Vernier Transit, and it need only be added here, that in this, as well as other instruments having two plates, moving upon sockets independent of each other, the levels, when adjusted on one plate, should still keep their position when both are clamped together and turned upon a common socket.

Otherwise, however accurately the telescope might trace a vertical line, when revolved upon the socket of one plate, it would give a very different result as soon as the position of the other plate was changed.

THE NEEDLE and telescope with its other attachments being adjusted, as described in our account of the Vernier Transit, we shall here consider only that of the

LEVEL ON TELESCOPE.—For the adjustment of this attachment we shall give two methods, the first being that usually practiced by us.

1. First level the instrument carefully, and with the clamp and tangent movement to the axis, make the telescope horizontal as near as may be with the eye, then having the line of collimation previously adjusted, drive a stake at a convenient distance, say from one to three hundred feet, and note the height cut by the horizontal wire, upon a staff set on the top of the stake.

Fix another stake in the opposite direction, and at the same distance from the instrument, and without disturbing the telescope, turn the instrument upon its spindle, set the staff upon the stake, and drive in the ground, until the same height is indicated as in the first observation.

The top of the two stakes will then be in the same horizontal line, however much the telescope may be out of level.

Now remove the instrument from fifty to one hundred feet to one side of either of the stakes, and in line with both; again level the instrument, clamp the telescope as nearly horizontal as may be, and note the heights indicated, upon the staff placed first upon the nearest, and then upon the most distant stake.

If both agree, the telescope is level; if not, with the tangent screw move the wire over nearly the whole error, as shown at the distant stake, and repeat the observation as just described. Proceed thus until the horizontal wire will indicate the same height at both stakes, when the telescope will be truly horizontal.

Taking care not to disturb its position, bring the bubble into the centre by the little leveling nuts at the end of the tube, when the adjustment will be completed.

2. Choose a piece of ground nearly level, and having set the instrument firmly, level the plates carefully, and bring the bubble of the telescope into the centre with the tangent screw. Measure in any direction from the instrument, from one to three hundred feet, and drive a stake, and on the stake

set a staff and note the height cut by the horizontal wire, then take the same distance from the instrument in an opposite direction, and drive another stake.

On that stake set the staff and note the height cut by the wire when the telescope is turned in that direction.

The difference of the two observations is evidently the difference of level of the two stakes.

Set the instrument over the lowest stake, or that upon which the greatest height was indicated, and bring the levels on the plates and telescope into adjustment as at first.

Then with the staff, measure the perpendicular distance from the top of the stake to the centre of one of the horizontal cross wire screw heads; from that distance subtract the difference of level between the two stakes and mark the point on the staff thus found; place the staff on the other stake, and with the tangent screw bring the horizontal wire to the mark just found, and the line will be level.

The telescope now being level, bring the bubble of the level into the centre, by turning the little nuts at the end of the tube, and noting again if the wires cut the point on the staff; screw up the nuts firmly and the adjustment will be completed.

With such a level carefully adjusted, the engineer, by taking equal fore and back sights, can run horizontal lines with great rapidity, and a good degree of accuracy.

*To use the Surveyor's Transit.*

In surveying with this instrument, the plates must be set so that the zeros of the circle and the verniers correspond, and firmly clamped together, the eye end of the telescope being placed over the south side of the compass circle, in the position shown in the engraving.

The surveyor may then proceed precisely as with the plain compass.

**TO TURN OFF ANGLES.**—When angles are to be measured independently of the needle, proceed precisely as directed in the description of the Railroad Compass.

**THE VARIATION OF THE NEEDLE** is also set off as mentioned in our account of that instrument.

*Sizes of the Surveyor's Transit.*

We make three sizes of the Surveyor's Transit, viz :

The 4-inch needle, with divided horizontal limb of 6 inches,

The 5-inch needle, with limb of  $6\frac{1}{2}$  inches, and

The  $5\frac{1}{2}$ -inch needle, with limb of 7 inches diameter.

They are all used with the light adjusting tripod head already mentioned.



The average weights of the three sizes, exclusive of the tripod legs, and with plain telescopes, are respectively as follows :

4-inch needle	- - - - -	12 lbs.
5-inch needle	- - - - -	13 lbs.
5½-inch needle	- - - - -	14 lbs.

*Merits of the Surveyor's Transit.*

In this instrument, as just described, the surveyor will recognize advantages not possessed by any other instrument with which we are acquainted.

Combining the capabilities of a needle instrument, with a fine telescope, and the accuracy of a divided limb and verniers, and having also the means for turning off the variation of the needle ; it is for a mixed practice of accurate surveying and engineering, such indeed as is required by most city engineers, the best instrument ever constructed.

THE LEVELING INSTRUMENT.

Of the different varieties of the leveling instrument, that termed the Y Level, has been almost universally preferred by American engineers, on account of the facility of its adjustment and superior accuracy.

Of these levels we manufacture four different sizes, having telescopes of sixteen, eighteen, twenty, and twenty-two inches long, respectively.

The engraving on page 91 represents our twenty inch Level; that of the sixteen inch telescope will be shown beyond.

We shall consider the several parts of the instrument in detail :

THE TELESCOPE has at each end a ring of bell-metal, turned very truly and both of exactly the same diameter ; by these it revolves in the wyes, or can be at pleasure clamped in any position when the clips of the wyes are brought down upon the rings, by pushing in the tapering pins.

The telescope has a rack and pinion movement to both object and eye-glasses, an adjustment for centering the eye-piece, shown at A A, in the longitudinal section of the telescope, (page 105,) and another seen at C, C, for ensuring the accurate projection of the object-glass, in a straight line.

Both of these are completely concealed from observation and disturbance by a thing ring which slides over them.

The telescope has also a shade over the object-glass, so



made, that whilst it may be readily moved on its slide over the glass, it cannot be dropped off and lost.

The shade of our sixteen inch level, is made to take off, like that of the Engineer's Transit.

The interior construction of the telescope will be readily understood from fig. 21, which represents a longitudinal section, and exhibits the adjustment which ensures the accurate projection of the object-glass slide.

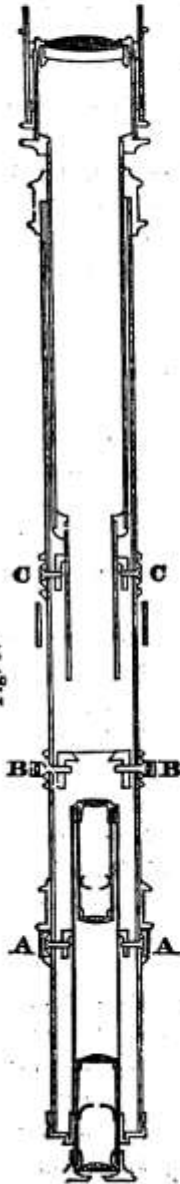

As this is peculiar to our instruments, and is always made by the maker so permanently as to need no further attention at the hands of the engineer, we shall here describe the means by which it is effected, somewhat in detail.

The necessity for such an adjustment will appear, when we state, that it is almost impossible to make a telescope tube, so that it shall be perfectly straight on its interior surface.

Such being the case, it is evident that the object-glass slide which is fitted to this surface, and moves in it, must partake of its irregularity, so that the glass and the line of collimation depending upon it, though adjusted in one position of the slide will be thrown out when the slide is moved to a different point.

To prove this, let any level be selected which is constructed in the usual manner, and the line of collimation adjusted upon an object taken as near as the range of the slide will allow; then let another be selected, as distant as may be clearly seen; upon this revolve the wires, and they will almost invariably be found out of adjustment, sometimes to an amount fatal to any confidence in the accuracy of the instrument. The arrangement adopted by us to correct this imperfection, and which so perfectly accomplishes its purpose, is shown in the adjoining cut, fig. F.

Here are seen the two bearings of the

object-glass slide, one being in the narrow bell-metal ring, which slightly contracts the diameter of the main tube, the other in the small adjustable ring, also of bell-metal, shown at C C, and suspended by four screws in the middle of the telescope.

Advantage is here taken of the fact, that the rays of light are converged by the object-glass, so that none are obstructed by the contraction of the slide, except those which diverge, and which ought always to be intercepted, and absorbed in the blackened surface of the interior of the slide.

Now, in such a telescope, the perfection of movement of the slide, depends entirely upon its exterior surfaces, at the points of the two bearings.

These surfaces are easily and accurately turned, concentric, and parallel with each other, and being fitted to the rings, it only remains necessary to adjust the position of the smaller ring, so that its centre will coincide with that of the optical axis of the object-glass.

When this has been once well done, no further correction will be necessary, unless the telescope should be seriously injured.

The manner in which the adjustment of the object-glass slide is effected, will be considered when we come to speak of the other adjustments.

**RACK AND PINION.**—As seen in the engraving, our Level telescopes are usually furnished with the ordinary rack and pinion movement to both object and eye tubes.

The advantages of an eye-piece pinion, are, that the eye-piece can be shifted without danger of disturbing the telescope, and that the wires are more certainly brought into distinct view, so as to avoid effectually any error of observation, arising from what is termed the instrumental parallax.

The position of the pinion on the tube is varied in different instruments according to the choice of the engineer.

We usually place our object slide pinion on the top of Transit telescopes, and on the side of those of the Level. The pinion of the eye tube is always placed on the side of the telescope.

**THE LEVEL** or ground bubble tube is attached to the under side of the telescope, and furnished at the different ends with the usual movements, in both horizontal and vertical directions.

The aperture of the tube, through which the glass vial appears, is about five and one-fourth inches long, being

crossed at the centre by a small rib or bridge, which greatly strengthens the tube.

The level scale which extends over the whole length, is graduated into spaces a little coarser than tenths of an inch, and figured at every fifth division, counting from zero at the centre of the bridge; the scale is set close to the glass.

The bubble vial is made of thick glass tube, selected so as to have an even bore from end to end, and finely ground on its upper interior surface, that the run of the air bubble may be uniform throughout its whole range.

The sensitiveness of a ground level, is determined best by an instrument called a level tester, having at one end two Y's to hold the tube, and at the other a micrometer wheel divided into hundredths, and attached to the top of a fine threaded screw which raises the end of the tester very gradually.

The number of divisions passed over on the perimeter of the wheel, in carrying the bubble over a tenth of the scale, is the index of the delicacy of the level. In the tester which we use, a movement of the wheel ten divisions to one of the scale, indicates the degree of delicacy generally preferred for railroad engineering.

For canal work practice, a more sensitive bubble is often desired, as for instance, one of seven or eight divisions of the wheel, to one of the scale.

THE WYES of our levels are made large and strong, of the best bell-metal, and each have two nuts, both being adjustable with the ordinary steel pin.

The clips are brought down on the rings of the telescope tube by the Y pins, which are made tapering, so as to clamp the rings very firmly.

THE LEVEL BAR is made round, of well hammered brass, and shaped, so as to possess the greatest strength in the parts most subject to sudden strains.

Connected with the level bar is the head of the tripod socket.

THE TRIPOD SOCKET is compound; the interior spindle, upon which the whole instrument is supported, is made of steel, and nicely ground, so as to turn evenly and firmly in a hollow cylinder of bell-metal; this again, has its exterior surface fitted and ground to the main socket of the tripod head.

The bronze cylinder is held upon the spindle by a washer and screw, the head of this having a hole in its centre, through which the string of the plumb bob is passed.

The upper part of the instrument, with the socket, may thus be detached from the tripod head; and this, also, as in

the case of all our instruments, can be unscrewed from the legs, so that both may be conveniently packed in the box.

A little under the upper parallel plate of the tripod head, and in the main socket, is a screw which can be moved into a corresponding crease, turned on the outside of the hollow cylinder, and thus made to hold the instrument in the tripod, when it is carried upon the shoulders.

It will be seen from the engraving, that the arrangement just described allows long sockets, and yet brings the whole instrument down as closely as possible to the tripod head, both objects of great importance in the construction of any instrument.

THE TRIPOD HEAD has the same plates and leveling screws, as that described in the account of the Engineer's Transit; the tangent screw, however, is commonly single.

For our sixteen inch level we make a smaller tripod head, resembling that used with the lighter Engineer's Transit.

### THE Y LEVEL.

SIXTEEN INCH TELESCOPE.

No. 382.

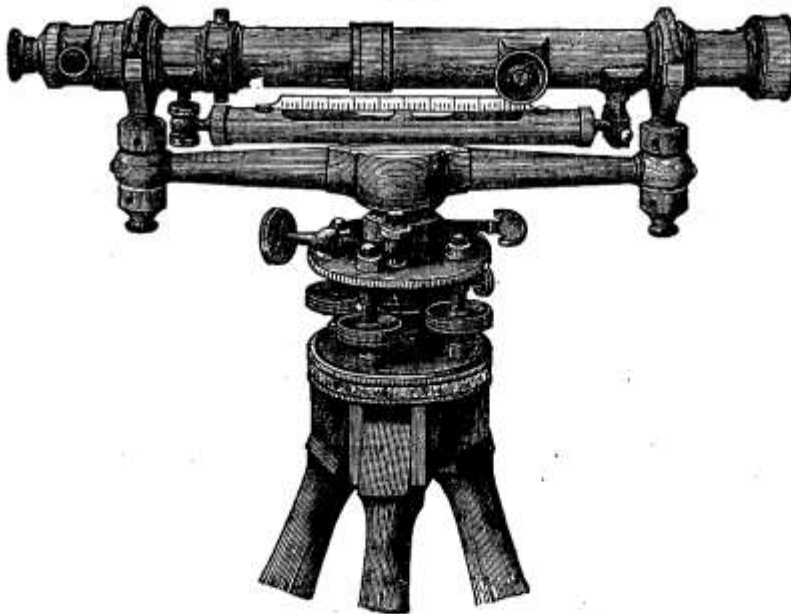

#### *The Adjustments.*

Having now completed the description of the different parts of the Leveling Instrument, we are ready to proceed with their adjustments, and shall begin with that of the object-slide, which, although always made by the maker, so

permanently as to need no further attention, at the hands of the engineer, unless in cases of derangement by accident, is yet peculiar to our instruments and therefore not familiar to many engineers.

**To ADJUST THE OBJECT SLIDE.**—The maker selects an object as distant as may be distinctly observed, and upon it adjusts the line of collimation, in the manner hereafter described, making the centre of the wires to revolve without passing either above or below the point or line assumed.

In this position, the slide will be drawn in nearly as far as the telescope tube will allow.

He then, with the pinion head, moves out the slide until an object, distant about ten or fifteen feet, is brought clearly into view; again revolving the telescope in the Y's, he observes whether the wires will reverse upon this second object.

Should this happen to be the case, he will assume, that as the line of collimation is in adjustment for these two distances, it will be so for all intermediate ones, since the bearings of the slide are supposed to be true, and their planes parallel with each other.

If however, as is most probable, either or both wires fail to reverse upon the second point, he must then, by estimation, remove half the error by the screws C C, (fig. F,) at right angles to the hair sought to be corrected, remembering at the same time, that on account of the inversion of the eye-piece, he must move the slide in the direction which apparently increases the error. When both wires have thus been treated in succession, the line of collimation is adjusted on the near object, and the telescope again brought upon the most distant point; here the tube is again revolved, the reversion of the wires upon the object once more tested, and the correction, if necessary, made in precisely the same manner.

He proceeds thus, until the wires will reverse upon both objects in succession; the line of collimation will then be in adjustment at these and all intermediate points, and by bringing the screw heads, in the course of the operation, to a firm bearing upon the washers beneath them, the adjustable ring will be fastened so as for many years to need no further adjustment.

When this has been completed, the thin brass ferule is slipped over the outside ring, concealing the screw heads, and avoiding the danger of their disturbance by an inexperienced operator.

In effecting this adjustment it is always best to bring the wires into the centre of the field of view, by moving the little screws A A (fig. F,) working in the ring which embraces the eye-piece tube.

Should the engineer desire to make this adjustment, it will be necessary to remove the bubble tube, in order that the small screw immediately above its scale may be operated upon with the screw driver.

The adjustment we have now given is preparatory to those which follow, and are common to all leveling instruments of recent construction, and are all that the engineer will have to do with in using our own instruments. What is still necessary then is—

1. *To adjust the line of collimation*, or in other words, to bring both wires into the optical axis, so that their point of intersection will remain on any given point, during an entire revolution of the telescope.

2. *To bring the level bubble parallel* with the bearings of the Y rings, and with the longitudinal axis of the telescope.

3. *To adjust the wyes*, or to bring the bubble into a position at right angles to the vertical axis of the instrument.

To ADJUST THE LINE OF COLLIMATION, set the tripod firmly, remove the Y pins from the clips, so as to allow the telescope to turn freely, clamp the instrument to the tripod head, and by the leveling and tangent screws, bring either of the wires upon a clearly marked edge of some object, distant from one to five hundred feet.

Then with the hand carefully turn the telescope half way around, so that the same wire is compared with the object assumed.

Should it be found above or below, bring it half way back by moving the capstan head screws at right angles to it, remembering always the inverting property of the eye-piece; now bring the wire again upon the object and repeat the first operation until it will reverse correctly.

Proceed in the same manner with the other wire until the adjustment is completed.

Should both wires be much out, it will be well to bring them nearly correct before either is entirely adjusted.

When this is effected, slip off the covering of the eye-piece centering screws, shown in the sectional view (fig. F) at A A, and move each pair in succession with a small screw driver, until the wires are brought into the centre of the field of view.

The inversion of the eye-piece does not affect this operation, and the screws are moved direct.



To test the correctness of the centering, revolve the telescope, and observe whether it appears to shift the position of an object.

Should any movement be perceived, the centering is not perfectly effected.

It may here be repeated, that in all telescopes the position and adjustment of the line of collimation depends upon that of the object-glass; and therefore, that the movement of the eye-piece does not effect the adjustment of the wires in any respect.

When the centering has been once effected it remains permanent, the cover being slipped over to conceal and protect it from derangement at the hands of the curious, or inexperienced operator.

To ADJUST THE LEVEL BUBBLE.—Clamp the instrument over either pair of leveling screws, and bring the bubble into the centre of the tube.

Now turn the telescope in the wyes, so as to bring the level tube on either side of the centre of the bar. Should the bubble run to the end it would show that the vertical plane, passing through the centre of the bubble, was not parallel to that drawn through the axis of the telescope rings.

To rectify the error, bring it by estimation half way back, with the capstan head screws, which are set in either side of the level holder, placed usually at the object end of the tube.

Again bring the level tube over the centre of the bar, and adjust the bubble in the centre, turn the level to either side, and if necessary, repeat the correction until the bubble will keep its position, when the tube is turned half an inch or more, to either side of the centre of the bar.

The necessity for this operation arises from the fact, that when the telescope is reversed end for end in the wyes in the other and principal adjustment of the bubble, we are not certain of placing the level tube in the same vertical plane, and therefore, it would be almost impossible to effect the adjustment without a lateral correction.

Having now, in great measure, removed the preparatory difficulties, we proceed to make the level tube parallel with the bearings of the Y rings.

To do this, bring the bubble into the centre with the leveling screws, and then without jarring the instrument, take the telescope out of the wyes and reverse it end for end. Should the bubble run to either end, lower that end.



or what is equivalent, raise the other by turning the small adjusting nuts, on one end of the level, until by estimation half the correction is made; again bring the bubble into the centre and repeat the whole operation, until the reversion can be made without causing any change in the bubble.

It would be well to test the lateral adjustment, and make such correction as may be necessary in that, before the horizontal adjustment is entirely completed.

To ADJUST THE WYES.—Having effected the previous adjustments, it remains now to describe that of the wyes, or, more precisely, that which brings the level into a position at right angles, to the vertical axis, so that the bubble will remain in the centre during an entire revolution of the instrument.

To do this, bring the level tube directly over the centre of the bar, and clamp the telescope firmly in the wyes, placing it as before, over two of the leveling screws, unclamp the socket, level the bubble, and turn the instrument half way around, so that the level bar may occupy the same position with respect to the leveling screws beneath.

Should the bubble run to either end, bring it half way back by the Y nuts on either end of the bar; now move the telescope over the other set of leveling screws, bring the bubble again into the centre and proceed precisely as above described, changing to each pair of screws, successively, until the adjustment is very nearly perfected, when it may be completed over a single pair.

The object of this approximate adjustment, is to bring the upper parallel plate of the tripod head into a position as nearly horizontal as possible, in order that no essential error may arise, in case the level, when reversed, is not brought precisely to its former situation. When the level has been thus completely adjusted, if the instrument is properly made, and the sockets well fitted to each other, and the tripod head, the bubble will reverse over each pair of screws in any position.

Should the engineer be unable to make it perform correctly, he should examine the outside socket carefully to see that it sets securely in the main socket, and also notice that the clamp does not bear upon the ring which it encircles.

When these are correct, and the error is still manifested, it will, probably, be in the imperfection of the interior spindle.

After the adjustments of the level have been effected, and the bubble remains in the centre, in any position of the socket, the engineer should carefully turn the telescope in

the wyes, and sighting upon the end of the level, which has the horizontal adjustments along each side of the wye, make the tube as nearly vertical as possible.

When this has been secured, he may observe, through the telescope, the vertical edge of a building, noticing if the vertical hair is parallel to it; if not, he should loosen two of the crosswire screws at right angles to each other, and with the hand on these, turn the ring inside, until the hair is made vertical; the line of collimation must then be corrected again, and the adjustments of the level will be complete.

*To use the Level.*

When using the instrument the legs must be set firmly into the ground, and neither the hands nor person of the operator be allowed to touch them, the bubble should then be brought over each pair of leveling screws successively, and leveled in each position, any correction being made in the adjustments that may appear necessary.

Care should be taken to bring the wires precisely in focus, and the object distinctly in view, so that all errors of parallax may be avoided.

This error is seen when the eye of an observer is moved to either side of the centre of the eye-piece of a telescope, in which the foci of the object and eye-glasses, are not brought precisely upon the cross-wires and object; in such a case, the wires will appear to move over the surface, and the observation will be liable to inaccuracy.

In all instances the wires and object, should be brought into view so perfectly, that the spider lines will appear to be fastened to the surface, and will remain in that position however the eye is moved.

If the socket of the instrument becomes so firmly set in the tripod head as to be difficult of removal in the ordinary way, the engineer should place the palm of his hand under the wye nuts at each end of the bar, and give a sudden upward shock to the bar, taking care also to hold his hands so as to grasp it the moment it is free.

*Weight of Leveling Instruments.*

The average weights of the different sizes of this instrument, exclusive of the tripod legs, are as follows:

16-inch telescope.....	11½ lbs
18-inch do .....	12 do
20-inch do .....	12½ do
22-inch do .....	13 do

## THE NEW BUILDERS' LEVEL.

Fig. 383.

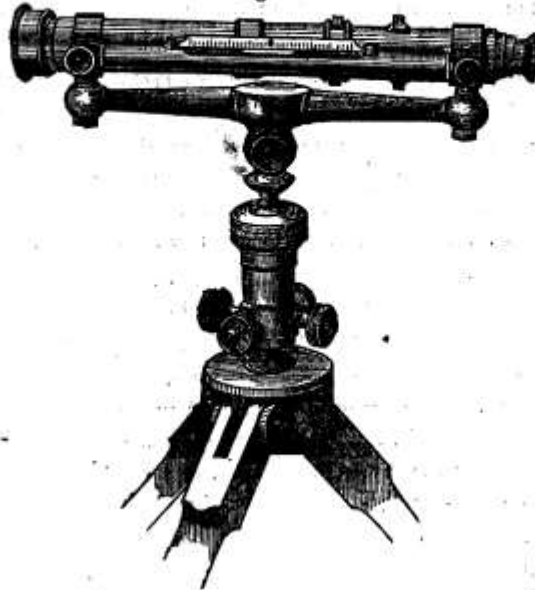

In addition to the ordinary Engineer's Level just described, we also manufacture several second class Leveling Instruments, two of which are referred to in our Price List, under the names of the Farm and Builders' Level. Both instruments have essentially the same arrangement of parts, and the same adjustments as the Engineer's Level, but are of less expensive construction.

We have also just introduced a New Builders' Level, shown in fig. 383, which for compactness, simplicity and economy is, we think, superior to any instrument of the kind we have ever seen.

In this Level, the wyes are dispensed with, the telescope resting upon the ends of the bar, by the two similar faces of octagonal shaped prisms, which surround the tube at either end.

The telescope is held on the bar by a stout screw at each end; the heads of these screws are shown on the under side of the bar, and are bored to admit the usual adjusting pin.

A strong spiral spring is placed in a recess in the upper side of each end of the bar, and serves in connection with the screws, to effect the third adjustment of the Level.

These springs are of course removed, while the other adjustments are in progress, and the telescope allowed to rest directly upon the bar.

## LEVELS.

The level tube is now placed above the telescope tube, and is adjusted at one end by two movable nuts.

The instrument is set on a ball placed in the adjusting socket, and is easily and accurately leveled.

The adjustments of this instrument are made in the same order, and almost precisely in the same manner, as those of the Engineers' Level, described on pages 91-98, and need but a brief description.

1. The line of collimation is adjusted, by making the wires reverse upon any given point, when the telescope is turned half-way round, so as to rest upon opposite faces of the prisms.

2. The level is adjusted, by turning the telescope end for end upon the bar, the bubble being made to come to the centre in both positions.

3. The bubble is brought into a position at right angles to the vertical axis, (the adjustment of the wyes in ordinary levels,) by releasing or compressing the springs at the ends of the bar, so that the bubble will come into the centre, as the instrument is turned upon its spindle, over both pairs of leveling screws in succession.

The price of this instrument, as shown in fig. 383, with box, &c., complete, is only \$50.

No. 384 represents a very simple form of leveling instrument, well suited for giving the levels in ditching, or for any other occasions where very great accuracy is not required. It consists of a straight

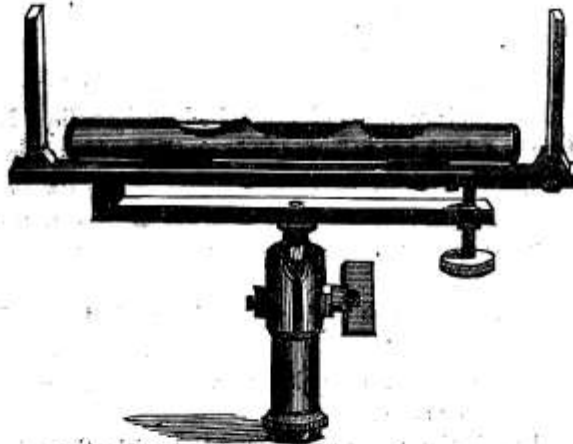

384

level bulb, about ten inches long, mounted on a straight bar of brass, to the ends of which, and at right angles to it, two upright pieces of brass are attached; near the top of these uprights a horizontal cut is made in each, exactly at the same distance from the main bar. The bar with level and sights is attached by a joint to a second bar of the same width, but much shorter. Through the second bar, and on the opposite end of it from the joint, a screw with milled head passes and presses against the under side of the main bar. To the second bar a ball and socket joint is screwed, to which a tripod or jacob staff can be fitted.

After placing the instrument in position and leveling as near as possible by the ball and socket, it is accurately leveled by turning the milled head of the screw, which raises or lowers the main plate carrying the level and sights.

**HAND LEVELS.**

In preliminary surveys the engineer finds it very convenient to have a pocket instrument of some kind, for ascertaining approximately the relative levels of two distant points.

No. 394 represents one of these instruments. It consists of a square piece of brass, with stems attached to two of the opposite corners; to one of these stems a ball and socket is attached, having a small handle; to the other stem a screw with heavy head. A triangular cut is made through the square (see unshaded part of cut); a piece of fine plate looking glass is placed on the square and secured to it by a metal rim and screws; the part of the glass opposite the triangular cut has the silvering taken off; a fine line is drawn from corner to corner, across the face of the glass, cutting the base of the triangular opening at right angles.

To use it, take it by the handle above the ball and socket, and hold the looking glass side about eighteen inches from the eye; raise and lower the hand until the eye is seen on the line in the looking-glass, then run the eye along the line to the opening, and all objects on a level with the eye will be cut by the line.



394

**LOCK'S LEVEL.**

Another form of pocket level, called Lock's hand level, is represented by No. 395. It is a brass or German silver tube, five inches long by three-fourths of an inch in diameter. One end has a draw tube, with half of a magnifying lens fitted in it; the other end is either open or fitted with a plain piece of plate glass; near this end there is an opening cut in the tube, and over it a spirit level is carefully adjusted; the frame which holds the spirit level has an opening cut in it directly over the opening in the tube, also one on the outside of the frame; directly under the opening in the tube a very small rectangular prism is adjusted, which occupies a little less than one-half the



395

diameter of the tube; a fine line is drawn across the middle of the level. When the instrument is used, the eye is placed at the small hole in the end, and the draw tube pulled out until the line on the level is seen distinctly through the half lens and the prism; now raise or lower very carefully the end of the tube which has the level on it until the centre of the bubble stands directly over the line, then all points at a distance which are seen through the vacant half of the tube and cut by the line are on the same level as the observer's eye. After a little practice, levels of considerable extent can be taken with either 394 or 395 quite accurately.

**THE CLYNOMETER.**

This instrument is used for ascertaining the angle of dip in rocks and the slope of embankments and excavations. It is a spirit level

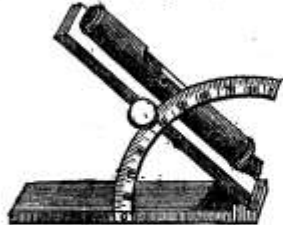

398

attached to an oblong bar of brass; which is hinged to a second bar of the same size; to the second bar a graduated arc is attached, which passes through a notch with clamp and screw in the side of the first bar. To use the instrument, clean a place upon the rock parallel with the dip or inclination of the strata; then place the flat surface of the second bar on it, and raise the bar with level until the bubble stands in the middle of the tube; then tighten the clamp screw, and the

division of the arc which is on a line with the under side of that bar is the angle of inclination. For taking the inclination of long lines, sights are attached to the bar which has the level on it.

**L. C. STEPHENS' PATENT COMBINATION RULE.**

The engravings illustrate an instrument invented by L. C. Stephens, and patented by him January 12th, 1858, which combines in itself a CARPENTER'S RULE, SPIRIT LEVEL, SQUARE, PLUMB, BEVEL, INDICATOR, BRACE SCALE, DRAUGHTING SCALE, T SQUARE, PROTRACTOR, RIGHT ANGLE TRIANGLE, and with a straight edge can be used as a PARALLEL RULER, all the parts of which in their separate application are perfectly reliable.

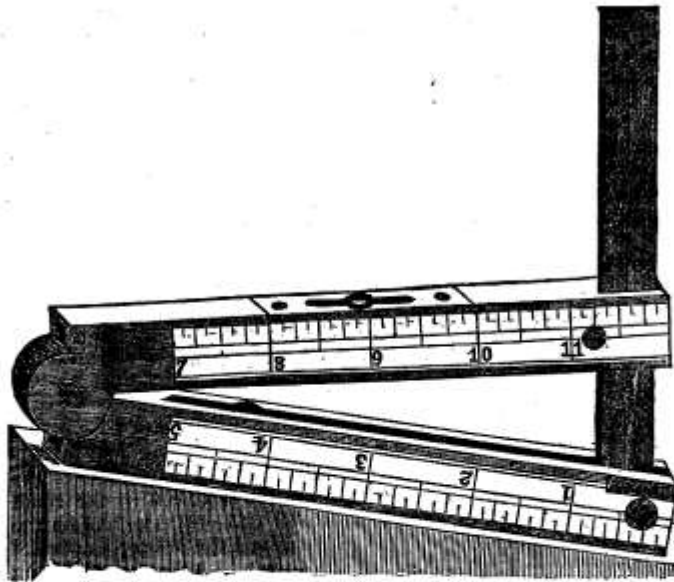
**EXPLANATION OF THE RULE.**

It is made of boxwood, with one joint, and is well protected with heavy brass binding. The plate which protects the glass, being put on with screws, can be removed, should it by accident become necessary to insert a new glass.

When folded it is six inches long, one and three-eighths inches wide, and three-eighths of an inch thick, and weighs the same as an ordinary broad bound rule. The cuts (which are exactly half size) represent the rule in three positions: first, as a *Spirit Level*; second, as a *Try-square Level* and *Plumb*; third, as a *Clynometer*, or *Slope Level*, in which it is represented in taking the angle or inclination of an inclined plane—the top of a desk, for instance.

The steel blade folds like a knife-blade into the part which holds it. One side of the blade is graduated, and the figures 5, 10, 15, 20 to 45, denote the *degree* of the angles which are formed by opening the legs of the rule, the blade sliding through the groove in the end of the leg.

When extended to 45 of course the angle is  $45^\circ$ , and the blade has fallen  $27\frac{1}{2}^\circ$  from a right angle or square. Hence the angles formed by the leg and blade *decrease* just one-half as fast as the angles formed by opening the legs of the rule *increase*. The upper edge of the other side of the blade is also graduated into inches and eighths, and numbered 1, 2, 3, 4, 5, 6, the graduations decreasing towards the end of the blade. This scale shows the *pitch to the foot*. Thus in the cut which represents the rule as a *Slope Level*, the angle indicated is  $9^\circ$ , and the *pitch* of that angle or inclination, as shown on the other side of the blade, is seven-eighths and one-sixteenth of an inch on a base line of six inches, or one and seven-eighths inches on a base of one foot. By opening the rule  $15^\circ$ , the scale on the other side shows a pitch of one and five-eighths inches in six inches, or two and three-eighths inches in a foot.

The utility of these scales will be readily seen by those who have occasion to ascertain the angle or pitch to the foot of any inclined plane. The plumber, for instance, with this instrument can ascertain not only the angle, but the pitch to the foot of any roof.

Engineers and artillerymen find the instrument invaluable, as by its aid any gun can be instantly adjusted to the proper degree of elevation.

The inner edge of the leg which holds the glass is also graduated to measure the angles, which are formed by turning the blade in the leg which holds it, which arrangement is especially adapted to iron planers. These degrees show how much the right angle is reduced as the blade falls from that position. The machinist desires to reduce a piece of iron to a certain bevel, but instead of going to the planer "to cut and try," as is usually done, he finds the *degree* of the angle he wants to apply the instrument to his pattern; then by turning the index of the planer to the proper degree, he can cut the exact angle required. To apply it to a pattern, open the leg which holds the glass (keeping the blade down on the bottom of the groove) until the blade and leg in which it turns fit two sides of it, and observe the degree indicated by the blade. If at 40, then as before explained we know the pattern is just  $20^\circ$  less than a right angle or square, and to plane a piece of the same angle as the pattern, we place the index of the planer at  $20^\circ$ , the pattern being an angle of  $70^\circ$ , and  $70^\circ - 20^\circ = 90^\circ$ —a right angle or square. This application of the instrument, all mechanics who understand it greatly admire. The pattern-maker, by using this tool, saves the machinist considerable labor, both working by the same degree.

The surveyor will perceive its adaptation in the laying of angles. Open the part which holds the level until the end of the blade rests squarely upon the inside of it, and we have a T SQUARE. In this position it is also a RIGHT-ANGLE TRIANGLE, and with the aid of a straight-edge can be used as a PARALLEL RULER. One side of the blade is divided into twelfths, also the inside edge of the leg which holds it, which arrangement constitutes the BRACE SCALE. Place one point of the dividers on the third inch of the blade (while the rule



is in form of a square,) and extend the other over to the third inch on the scale of twelfths on the inside edge of the leg, and the distance between the two points of the dividers applied to the scale of twelfths on the rule will give the length of the brace in feet and inches; inches and twelfths on the rule representing feet and inches in the brace, of course.

The adaptation of this instrument to the measurement of height and distance is obvious from the following illustrations: A carpenter goes into the forest to find a tree which will furnish forty feet in length, of clear timber. He finds one which seems adapted to his purpose, but a bend or limb near the top leaves a doubt in his mind in regard to it. He now takes the instrument from his pocket and measures off forty feet in any direction from the tree, and marks the point where the measurement terminates; then fixes the leg which holds the level at an angle of  $45^\circ$ , and places the instrument upon this point, (taking care to keep it level;) then sights along the leg into the tree, and if the line of sight strikes below the bend or limb, he is safe in cutting the tree. To measure the height of a pole, tree, or house, adjust the rule to an angle of  $45^\circ$ , and recede from the object until a line of sight along the base of the instrument will strike the bottom of the object, and another through the raised leg will strike the top of it; then measure the distance from the point where the instrument stands to the foot of the object, and you have the elevation. (If necessary to elevate the instrument, the height from the bottom of the object must be added to give the true result.) To measure the distance to any inaccessible object, the width of a river, for instance, lay off a base line of any convenient length, adjust the rule to a square and place the base of the instrument upon the line, so that a line of sight from the blade will strike the object, and mark the point upon the line where you commence operations; then change the instrument to an angle of  $45^\circ$ , and move it along the given base line until the line of sight from the raised leg strikes the object as in the former position; then measure the distance from the joint of the instrument to the point previously marked, and you have the distance to the object. The slotted screw which passes through the end of the leg which holds the level is used in adjusting the square, should it wear so as to require it. With a small screw-driver the blade may be raised or depressed by turning this screw either way. The square is strong, firm, and reliable, there being a heavy metal stop to prevent its going back too far, while it is held firmly in place, while in use, by a broad metal strap through which the screw passes.

Carpenters, joiners, ship-builders, draughtsmen, engineers, and all classes of mechanics are unanimous in the approval of this device, and the symmetrical arrangement of its parts.

## LEVELING RODS.

The two kinds most generally used by American engineers, are both sliding rods, divided into hundredths of a foot and reading by verniers to thousandths.

*Boston Rod.*

That known as the Boston or Yankee Rod, is formed of two pieces of light baywood or mahogany, each about six and a half feet long, connected together by a tongue, and sliding easily by each other, in both directions.

One side is furnished with a clamp screw and vernier at each end, the other carries the divisions, marked on strips of satin wood, inlaid on either side.

The target is a rectangle of wood, fastened near one end of the divided side, and having its horizontal line just three-tenths from the extremity.

The target being fixed, when any height is taken above six feet, the rod is changed end for end, and the divisions read by the other vernier; the height to which the rod can be extended, being a little over eleven feet.

This kind of rod is very convenient from its great lightness, but the parts are made too frail to endure the rough usage of this country, and, therefore, American engineers have generally given the preference to another, made heavier and more substantial.

*The New York Rod.*

This rod, which is shown in the engraving, as cut in two, so that the ends may be exhibited, is made of satin wood, in two pieces like the former, but sliding one from the other, the same end being always held on the ground, and the graduations starting from that point.

The graduations are made to tenths and hundredths of a foot, the tenth figures being black, and the feet marked with a large red figure.

## LEVELING RODS.



The front surface, on which the target moves, reads to six and a half feet ; when a greater height is required, the horizontal line of the target is fixed at that point, and the upper half of the rod, carrying the target, is moved out of the lower, the reading being now obtained by a vernier on the graduated side, up to an elevation of twelve feet.

The mountings of this rod are differently made by different manufacturers. We shall give those which we have adopted.

The target is round, made of thick brass, having, to strengthen it still more, a rib raised on the edge, which also protects the paint from being defaced.

The target moves easily on the rod, being kept in any position by the friction of the two flat plates of brass which are pressed against two alternate sides, by small spiral springs, working in little thimbles attached to the band which surrounds the rod.

There is also a clamp screw on the back, by which it may be securely fastened to any part of the rod.

The face of the target is divided into quadrants, by horizontal and vertical diameters, which are also the boundaries of the alternate colors with which it is painted.

The colors usually preferred are white and red : sometimes white and black.

The opening in the face of the target is a little more than a tenth of a foot long, so that in any position a tenth or a foot figure, can be seen on the surface of the rod.

The right edge of the opening is chamfered, and divided into ten equal spaces, corresponding with nine hundredths on the rod ; the divisions start from the horizontal line which separates the colors of the face.

The vernier like that on the other side of the rod, reads to thousandths of a foot,

The clamp, which is screwed fast to the lower end of the upper sliding piece, has a movable part which can be brought by the clamp screw firmly against the front surface of the

lower half of the rod, and thus the two parts immovably fastened to each other without marring the divided face of the rod.

## THE MINERS' COMPASS.

Fig. 448.



Consists essentially of a dipping needle, about  $2\frac{1}{2}$  inches long, which inclines towards any mass of iron and thus discovers its position.

When used for tracing ore, the observer should hold the ring in his hand, and keep the needle north and south, standing with his face to the west.

If held horizontal, it serves, of course, as a Pocket Compass, having also a brass cover not shown in the cut.

## THE POCKET COMPASS

Fig. 446.



This little instrument, shown with jacob-staff socket in fig. 446, though not used in extensive surveys like the larger compasses we have described, is found very convenient in making explorations, or in retracing the lines of government surveys, as in locating land warrants, &c.

The sights are made with a slote and a hair, on opposite sides; they also have joints near the base, so as to fold over each other above the glass, when the compass is packed in its case.

The circle is graduated to degrees, and figured from 0 to 90 each way, as in the larger instruments.

The needle is suspended upon a jeweled centre, and is raised by the lifter shown in the cut.

The jacob-staff socket is often used with the compass, being screwed to the under side, and detached at pleasure.

The mountings are all that are furnished, the staff itself being easily made out of a common walking stick.

We make two sizes of the pocket compass, differing mainly in the needle, which in one is two and a half, in the other three and a half inches long.

## General Matters.

### TRIPODS.

In the tripods of all our instruments, the upper part of the leg, is flattened, and fitted closely in the surfaces of the brass cheek pieces.

The cheeks are made very broad, and give a firm hold upon the leg, which may be tightened at any time by screwing up the bolts which pass through the top of the legs; this is especially necessary after the surface of the wood has been much worn.

The legs are round, and taper in each direction from a swell, turned about one-third the way down, from the head to the point.

The point, or shoe, is a tapering brass ferule, having an iron end; it is cemented, and riveted firmly to the wood.

The legs of all our tripods are about four feet eight inches long, from head to point. We make three sizes of tripods, which we will now separately describe.

1. THE COMPASS TRIPOD, seen in part in the cut of the vernier transit, and having the brass plate to which the cheeks are attached, three and three-fourth inches in diameter, and legs which are about one inch at the top, one and three-eighths at the swell, and seven-eighths at the bottom.

The legs are usually made of cherry, sometimes of mahogany, and the tripod is used with the various kinds of compasses, and with the vernier transit.

2. THE MEDIUM SIZED TRIPOD, shown with the surveyor's transit, and having a plate of same diameter as above, but

with the cheeks made considerably broader, by curving at each end; the legs being also about an eighth of an inch larger throughout.

This tripod has mahogany legs, and is used with the surveyor's transit, the light engineer's transit, and the sixteen inch level.

3. THE HEAVY TRIPOD, shown with the engineer's transit, having a brass plate of four and one-fourth inches diameter, with extended cheek pieces, and with legs one and three-eighths of an inch at the top, one and three-fourths at the swell, and one and an eighth at the point.

The heavy size has also mahogany legs, and is used with the engineer's transit, and larger leveling instruments.

#### *Lacquering.*

All instruments are covered with a thin varnish, made by dissolving gum shellac in alcohol, and applied when the work is heated.

As long as this varnish remains, the brass surface will be kept from tarnishing, and the engineer, by taking care not to rub his instrument with a dusty cloth, or to expose it to the friction of his clothes, can preserve its original freshness for a long time.

#### *Bronze Finish.*

Instead of the ordinary brass finish, some engineers prefer instruments blackened or bronzed. This is done with an acid preparation, after the work has been polished, and gives the instrument a very showy appearance, besides being thought advantageous on account of not reflecting the rays of the sun as much as the ordinary finish.

When well lacquered, the bronzing will last a considerable time, but as soon as it becomes a little worn the appearance of the instrument is much worse than one finished in the usual style.

## CHAINS.

### *Surveyors' Chains.*

FOUR POLE CHAINS.—The ordinary surveyor's chain is sixty-six feet, or four poles long, composed of one hundred links, each connected to the other by two rings, and furnished with tally marks at the end of every ten links.

In all the chains we manufacture, the rings are oval, are sawed, and well closed, the ends of the wire forming the hook

being also filed and bent close to the link, so as to avoid the danger of "kinking."

A link in measurement includes a ring at each end.

The handles are of brass, and each forms part of the end links, to which it is connected by a nut, by which also the length of the chain is adjusted.

The tallies are also of brass, and have one, two, three, or four, notches, as they are ten, twenty, thirty, or forty, links, from either end; the fiftieth link is rounded, so as to distinguish it from the others.

**TWO POLE CHAINS.**—In place of the four pole chain just described, many surveyors prefer one of two rods or thirty-three feet long, having but fifty links, and counted by its tallies from one end in a single direction.

**SNAP FOR ALTERING CHAINS.**—We often make four pole chains so arranged, that by detaching a steel snap in the middle, the two parts can be separated, and then one of the handles being removed in the same manner, and transferred to the forty-ninth link, a two pole chain is readily obtained. This modification is made whenever desired, and without any additional charge.

**SIZES OF WIRE.**—Our surveyors' chains are made of the best refined iron wire, of sizes No. 8 or 10, as may be preferred; the diameter of No. 10 wire being about one-eighth of an inch, and that of No. 8 wire nearly a sixteenth larger.

#### *Engineers' Chains*

Differ from the preceding, in that the links are each 12 inches long; the wire, also, is usually much stronger.

They are either fifty or one hundred feet long, and are furnished with handles, tallies, &c., and sometimes with a swivel in the middle to avoid being twisted in use.

In place of the round rings commonly made, we have substituted in these, and our other chains, rings of an oval form, and find them almost one-third stronger, though made of the same kind of wire.

**SIZES OF WIRE.**—The wire used for these chains is commonly of No. 5 or 6; the first being nearly one-fourth of an inch in diameter, while No. 6 wire is about one-sixteenth smaller.

The wire is of the first quality, and the whole chain is made in the most accurate and substantial manner.



*Steel Chains.*

Chains made of steel wire, though more costly than those which we have just described, are yet often preferred on account of their greater lightness and strength.

They are made of any desired size or length, generally of No. 10, rarely of No. 8 wire, and are very stiff and strong.

**BRAZED STEEL CHAINS.**—A very portable and excellent measure is made, by a light steel chain, each link and ring of which is securely *brazed*, after being united together and tested.

The wire generally used by us is of size No. 12, the rings are of oval form, the chain, though exceedingly light, is almost incapable of being either broken or stretched.

*Marking Pins.*

In chaining, there are needed ten marking pins, or chain stakes, made either of iron, steel, or brass wire, as may be preferred, about fourteen inches long, pointed at one end to enter the ground, and formed into a ring at the other, for convenience in handling.

They are sometimes loaded with a little mass of lead around the lower end, so as to answer as a plumb when dropped to the ground, from the suspended end of the chain.

*To use the Chain.*

In using the chain its length must be taken from its extreme ends, and the pins placed on the outside of the handles; it must be drawn straight and taut, and carefully examined to detect any kinks or other causes of inaccuracy.

Our chains are all carefully tested at every ten, sometimes at every link, and in their whole length by the U. S. standard, and when new may always be relied upon as correct.

But as all will alter, more or less, after long use in the field, it will be best for the surveyor to carefully lay down on a level surface, the exact length of the chain when yet new, marking also its extreme ends by monuments which will not be liable to disturbance.

He will thus have a standard measure of his own to which the chain can be adjusted from time to time and again be used with perfect confidence.

## TAPE MEASURES.

The best are Chesterman's steel tapes, made of a thin ribbon of steel, which is jointed at intervals, and wound up in a leathern case, having a folding handle.



414

These tapes are of all lengths, from thirty-three to one hundred feet, divided into inches and links, or more usually tenths of a foot, and links, the figures and graduations being raised on the surface of the steel.

The great cost of the steel tape has always prevented its general use, and the metallic tape of the same manufacturer is the only one commonly employed in American engineering.

These are of linen, and have also fine brass wires interwoven through their whole length.

They are thus measurably correct, even when wet.

They are mounted like the steel tapes, of like lengths, and similarly graduated.

## PRISMATIC AZIMUTH COMPASS.

With this instrument horizontal angles can be observed with great rapidity, and with considerable degree of accuracy. It is, consequently, a very valuable instrument to the military engineer, who can make his observations with it while holding it in his hand, with all the accuracy necessary for a military sketch. It is also a useful instrument for filling in the detail of an extensive survey; after the principal points have been laid down by means of observations made with the transit instruments, and for any purpose, in short, in which the portability of the instrument and rapidity of execution are of more importance than extreme accuracy.



449

For a complete description of the instrument, and how to use it, see page 115, Heather's Treatise on Mathematical Instruments.

## GEOLOGICAL COMPASS.

This is an ordinary pocket compass, to which is added attachments for taking angles of inclination in the strata of rocks. It is from two to two and a half inches in diameter, and has a ring like a watch; the dial is a metal rim, raised about one-eighth of an inch from the bottom of the compass, and divided into 360 equal parts or degrees; the needle has an agate centre and stop attachment. The bottom, or rather the face of the compass, is divided into 90 equal parts or degrees, from the North line to the West line, and also into the same number from the West to the South line,



451

—the 0 point being at the West line. A delicate pendulum, with pointer, swings upon the centre pin and traverses the arcs on the face. Through the ring of the compass box a metal slide is fixed, which pushes in under the bottom plate of the face. When the instrument is to be used for taking inclinations, pull out the metal slide and place the compass box upright, and resting it on its edge and the slide; if the surface on which the box is placed is perfectly level, the pendulum on the face will hang directly over the 0 point, but if the strata dips North or South, the index on the pendulum will point at the graduation which indicates the angle of inclination.

**THE UNIVERSAL SUN-DIAL,**

Is a pocket compass, over the face of which a metal rim is hinged, having its upper surface divided into the proper divisions to represent hours and minutes; a straight pin is fixed in the centre of the rim or dial, upon a bar, the ends of which revolve in the edge of the rim; when in use the pin is upright, and when not in use is turned down level with the rim. A graduated arc of 90 degrees is attached to the compass face, and passes through the outside edge of the dial rim; this arc is jointed at its base, so that it can be laid flat when the instru-

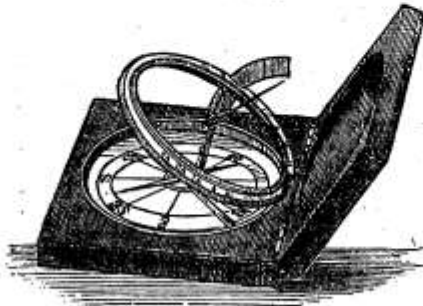

254

ment is not in use. To use this form of sun-dial, place it in the sun, as nearly level as possible; raise the graduated arc, then raise the dial rim, and bring the arrow on its outer edge to the degree on the arc which represents the latitude of the place; now lift the pin perpendicular to the plane of the dial rim, and turn the compass box around until the blue end of the needle is directly over the North line; the shadow of the upright pin will then be thrown across the dial rim, and the graduation which it falls upon will be the time of day.

**POCKET COMPASSES,**

Are small compasses, of sizes not too large to be carried with convenience in the pocket, and are very useful in traveling, in order that the relative positions of places may be known at all times. They are made of a great variety of plans and forms; as without stop and with stop to needle; with covers to face and without; with agate centres to needle and without, and with graduated dials and without. The stop to the needle is an arrangement by which the needle can be lifted off the centre pin and held tightly against the glass face, when the compass is not in use, and thereby prevent the rapid dulling of the point and wearing of the centre, which takes place when the needle is constantly in motion. The object of the cover is to prevent the glass which covers the face from getting broken, and the compass injured in other ways. The agate centre is a watch jewel, fixed in the centre of the needle, where it sets on the centre pin; the jewel being very smooth and hard causes the needle to vibrate and settle more correctly, and does not become worn by the point, though in constant use. The object of the graduated dial is to give the exact bearing of a place from a given point.

For description of the different kinds of drawing paper, pens, brushes, pencils, &c., their use and how to use them, see Warren's Manual of Drafting Instruments and Machinery, Vol. I, of this Catalogue.

# INDEX.

Azimuth Compass, . . . . .	109	Lyon's Tables, . . . . .	30
Beam Compass, . . . . .	2, 5, 39, 40	Lock's Level, . . . . .	25
Bow Pens, . . . . .	2, 5, 6, 40, 41	Map Perambulator, . . . . .	6, 41
Bow Pencils, . . . . .	2, 6, 40	Mapping Pens, . . . . .	33
Books, Field, . . . . .	30	Miner's Compass, . . . . .	104
" Level, . . . . .	30	Mouth Glue, . . . . .	33
" Transit, . . . . .	30	Odometer, . . . . .	25
" Miscellaneous, . . . . .	30	Paper, Drawing, . . . . .	29, 30
Cabinet Nests, . . . . .	32	" Tracing, . . . . .	30
Cases of Instruments, Brass, . . . . .	3	" Profile and Cross Section, . . . . .	30
" " " Ger. Silver, . . . . .	7	" Protractors, . . . . .	30
" " " Second quality, . . . . .	9	Parallel Rulers, . . . . .	19, 47
Chains, . . . . .	25, 106	" " (rolling,) . . . . .	12, 47
Clynometer, . . . . .	99	Pens, Mapping and Lithograph, . . . . .	33
Compound Ball, . . . . .	25, 74	Pencils, Lead, . . . . .	34
Combination Rule, . . . . .	27, 100	" Camel's Hair & Sable, . . . . .	34
Compasses, Surveyors', . . . . .	20, 52, 58	Perambulator, . . . . .	6
" Railroad, . . . . .	21, 79	Pins, Marking, . . . . .	25
" Transit, . . . . .	22, 62	Pillar Compasses, . . . . .	5
" Pocket and Boat, . . . . .	28, 29	Plumb Bobs, . . . . .	23
104, 110		Polar Planimeter, . . . . .	47
" Miners', Azimuth, . . . . .		Protractors, . . . . .	13, 14, 15, 16, 42
and Geological, . . . . .	23, 109	" Swiss and Paper, . . . . .	14, 15
Curves, Wood, . . . . .	18, 46	" Ivory & Boxwood, . . . . .	15, 16
" Horn, . . . . .	12, 46	" Bevil, . . . . .	14, 43
Dividers, Plain, . . . . .	1, 4, 10, 36	Railroad Pens, . . . . .	2, 6
" Hair, . . . . .	1, 4, 36, 37	Roulette or Dotting Pen, . . . . .	2, 6, 41
" with Pen and Pencil, . . . . .	1, 2, 4	Rules, Pocket, Rutledges, &c., . . . . .	27
" Bisecting, . . . . .	2, 5, 38	Saucers, Porcelain, . . . . .	32
" Pocket, . . . . .	4, 37	Scales, Ivory, . . . . .	15
" " (folding,) . . . . .	5, 38	" Boxwood and Triangu-	
" Proportional, . . . . .	2, 5, 39	lar, . . . . .	16, 45
" Three-legged, . . . . .	4, 38	" Paper and Gunter's . . . . .	16, 45
" Spacing, . . . . .	5, 36	Sector, Ivory, . . . . .	15, 45
Dotting Pens, . . . . .	2, 6, 41	Slabs, Porcelain, . . . . .	32
Drawing Pens, . . . . .	2, 6, 41	Slope Level, . . . . .	25
" " (double,) . . . . .	6	Squares, German Silver, Steel, &c. . . . .	17
" Paper, . . . . .	29, 31	Straight Edges, . . . . .	18, 45
" Board, . . . . .	18, 47	Steel Rules, . . . . .	17, 45
Gillott's Mapping Pens, . . . . .	33	Sun-Dial, Universal, . . . . .	111
Geological Compass, . . . . .	109	Surveyors' Chains, . . . . .	25
Hand Level, . . . . .	26	Swiss Instruments, . . . . .	10, 11, 12, 13
Horn Centre, . . . . .	12, 19, 47	Tacks, . . . . .	11, 19, 47
India Rubber and Ink, . . . . .	33	Tape Measures, . . . . .	26, 110
Knives, Erasing, . . . . .	34	Transit, Surveying, . . . . .	22, 62
Level, Hand, Slope and Lock's, . . . . .	25, 98	Tripod, . . . . .	25, 106
" Engineers and Builders' . . . . .	23,	Triangles of Wood and German	
87, 97		Silver, . . . . .	18, 46
" Pocket and Builders' . . . . .	24	T Squares, . . . . .	19, 46
Levelling Rod, . . . . .	25, 102	Water Colors, . . . . .	32, 33