



The Philadelphia Thermometer Company



Thermometers
Pyrometers
Hydrometers
Barometers
Hygrometers

GENERAL CATALOGUE



The PHILADELPHIA THERMOMETER COMPANY

915 Filbert Street
Philadelphia, Pa.
ESTABLISHED 1905

Manufacturers of
**High-Grade Indicating
Thermometers**
For All Purposes



Discounts allowed on all prices
Prices subject to change without notice

CORRECTIONS

Page No.	Numbers	should read	379
" "	15 Illustration No. 446	should read	445
" "	15 " " 447	" "	446
" "	27 " " 250B	" "	62B
" "	27 " " 62B	" "	250B
" "	41 " " 2050	" "	2065
" "	41 " " 2065	" "	2050
" "	38 Catalogue " 2008	" "	1° div.
" "	38 " " 2030	" "	10 "
" "	38 " " 2403	" "	10 "
" "	38 " " 2411	" "	10 "
" "	38 " " 2413	" "	10 "
" "	38 " " 2414	" "	10 "
" "	39 " " 2503	" "	10 "
" "	39 " " 2555	" "	10 "



FOREWORD

TEMPERATURE regulation is of paramount importance in the efficient and economical operation of nearly every industry.

Cognizant of this fact, we have, in presenting this catalogue, endeavored to illustrate thermometers that are in general considered standard types for the various industries; however, conditions prevailing throughout the many manufacturing processes differ so widely and are so innumerable that to produce a single type thermometer applicable to all circumstances would be impractical. Consequently we solicit correspondence relative to your particular requirements, which will enable us to assure our customers thermometers that are best adapted to their individual needs.

THE PHILADELPHIA
THERMOMETER CO.

IMPORTANT

On Orders and Inquiries

ALWAYS SPECIFY

- | | |
|--------------------------------|----------------------|
| 1—Size of case | 4—Temperature Range |
| 2—Straight or Angle form | 5—Type of connection |
| 3—Purpose for which to be used | 6—Size of thread |

WE REPAIR ALL MAKES OF THERMOMETERS

Realizing the fact that a broken thermometer often hinders production, we therefore maintain a department especially for the repair of thermometers, thereby assuring our customers prompt service at reasonable cost.

Thermometers repaired by us are put in first class condition and we guarantee them to be accurate.

WE GUARANTEE

Our instruments to be made of the best of materials and workmanship. They are rigidly inspected and tested before leaving our factory and are unconditionally guaranteed as to **QUALITY** and **ACCURACY**.

The Philadelphia Thermometer Co.

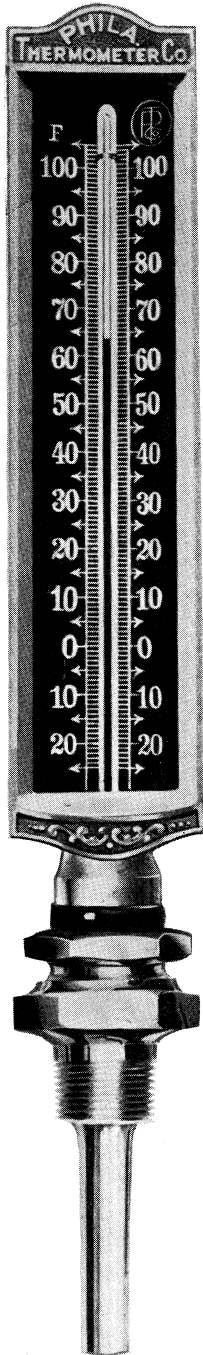

No. 242

INSULATED FEATURES

No. 242 shows an engineer type thermometer, with insulated feature, that prevents frosting over of scale case when used in brine or ammonia lines, where low temperatures are maintained.

Where the heat medium is air, gases or liquids, not agitated or in circulation; or materials that are poor heat conductors, such as dough, the insulated feature as shown (No. 360) prevents heat conduction between the bulb chamber and scale case, insuring greater accuracy by reducing the temperature lag to a minimum.

For insulation feature add \$1.50 to list price.

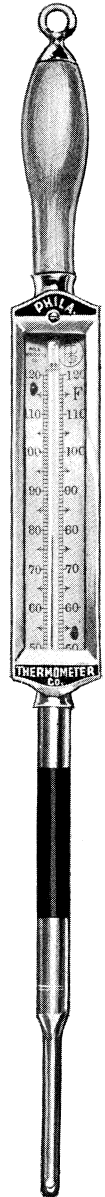

No. 360

PHILADELPHIA INDUSTRIAL THERMOMETERS
(Construction Features)

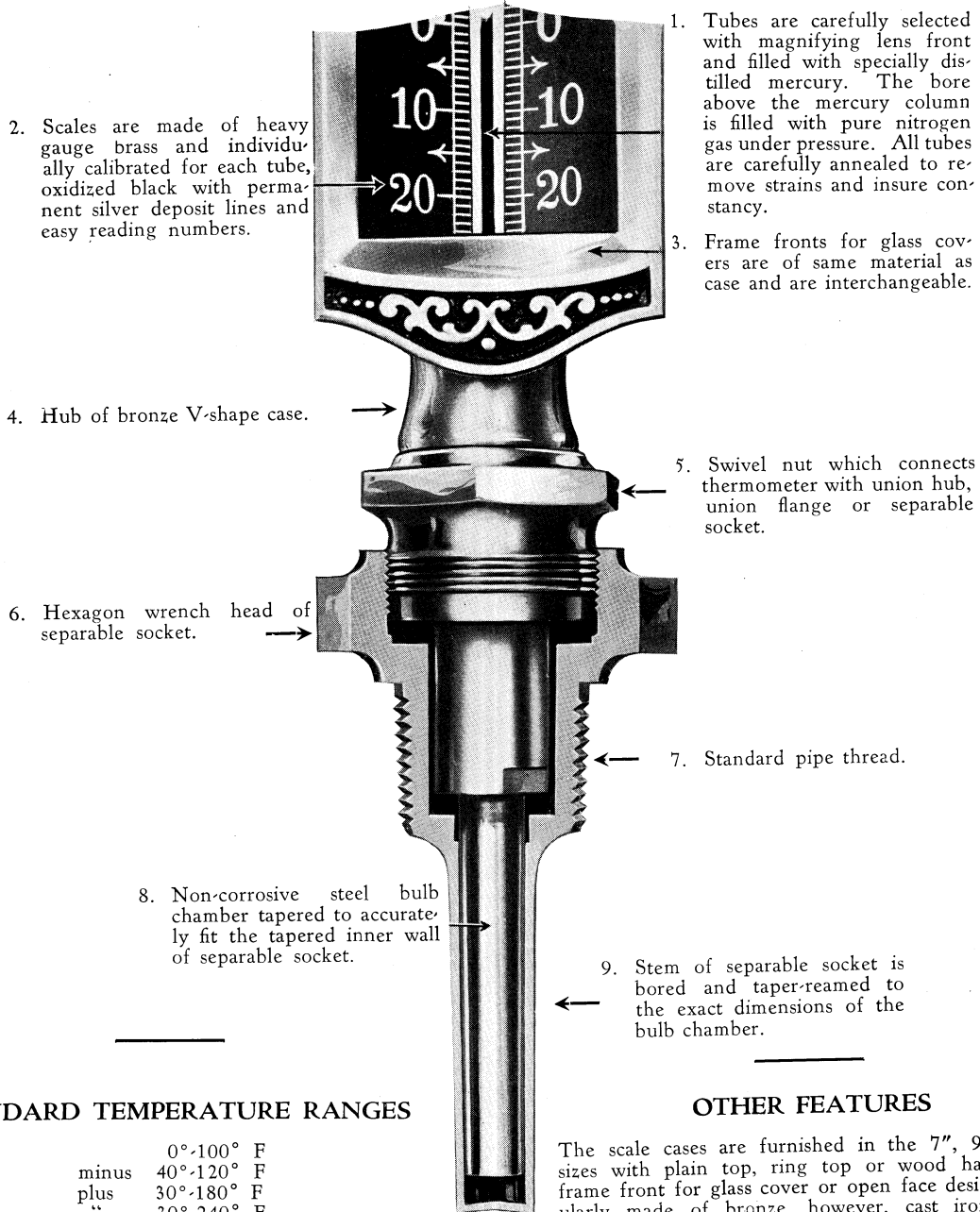

2. Scales are made of heavy gauge brass and individually calibrated for each tube, oxidized black with permanent silver deposit lines and easy reading numbers.

1. Tubes are carefully selected with magnifying lens front and filled with specially distilled mercury. The bore above the mercury column is filled with pure nitrogen gas under pressure. All tubes are carefully annealed to remove strains and insure constancy.
3. Frame fronts for glass covers are of same material as case and are interchangeable.

4. Hub of bronze V-shape case.

5. Swivel nut which connects thermometer with union hub, union flange or separable socket.

6. Hexagon wrench head of separable socket.

7. Standard pipe thread.

8. Non-corrosive steel bulb chamber tapered to accurately fit the tapered inner wall of separable socket.

9. Stem of separable socket is bored and taper-reamed to the exact dimensions of the bulb chamber.

STANDARD TEMPERATURE RANGES

	0°-100° F
minus	40°-120° F
plus	30°-180° F
"	30°-240° F
"	50°-300° F
"	50°-400° F
"	50°-500° F
"	100°-600° F
"	200°-750° F

Over 750° F and up to 1000° F add \$5.00 to list price.
170°-270° F with pressure scale.
200°-400° F with pressure scale.
7" scale case ranges up to 400° F only.
Ranges listed in centigrade if desired (no additional charge).

OTHER FEATURES

The scale cases are furnished in the 7", 9" or 12" sizes with plain top, ring top or wood handle top, frame front for glass cover or open face design. Regularly made of bronze, however, cast iron, nickel-plated will be furnished if specified. Aluminum case supplied on portable long stem types.

Regular forms include straight, 90° back angle, right or left side and reclined or inclined angles.

Various fittings include fixed thread, union connection, separable sockets, fixed flange, adjustable flange, union flange, flange with locknut and washer, adjustable hook, sanitary wall fittings and various types of guards.

(See Fittings, page 13.)

PHILADELPHIA SEPARABLE SOCKETS

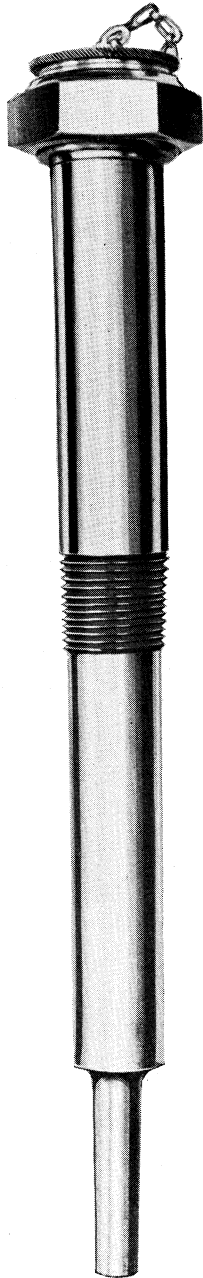

No. 706
Socket with Com-
bination Extension
neck and Extension
Stem

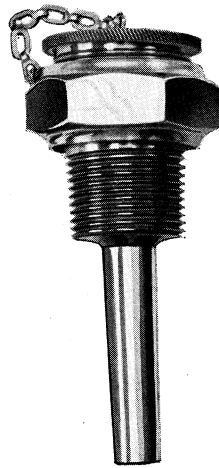

No. 700
Regular 4" Socket
Stem 3 1/2" inc.
Thread

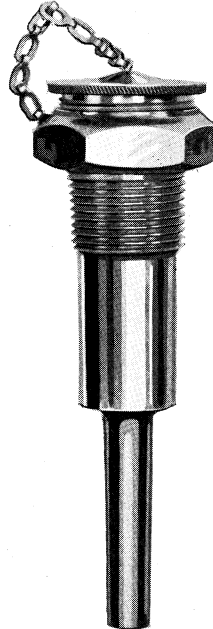

No. 701
Socket with
Extension Stem

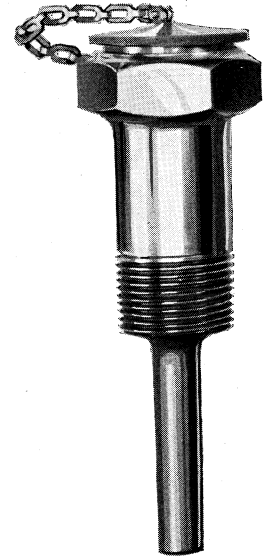

No. 702
Socket with
Extension Neck

The separable sockets are machined and taper reamed to accurately fit the tapered bulb chamber of the thermometer.

They are especially adapted to pipe lines, vats, kettles, etc.; where the thermometer may be withdrawn without leaving an opening.

Sockets are easily installed and if subject to corrosion it is more economical to change them periodically than to replace the thermometer.

All sockets of the same size thread and stem length are interchangeable.

Sockets are regularly made of bronze or steel at prices listed. For sockets made of special materials such as monel, copper, silver, etc., prices will be furnished on application.

Where a socket is required with a longer stem length than the regular form, specify the length below wrench head.

The "extension neck" socket is a term applied to a socket that has a space between the underside of wrench head and above the thread to take care of insulating coverings.

REGULAR FORM SEPARABLE SOCKETS

No.	Material	Stem Length Including Thread	Extension Neck	Size of Thread	Price Each
700	Brass or Steel	3 1/2"	x	3/4" or 1"	\$5.00
701	" " "	6"	x	" " "	6.00
702	" " "	3 1/2"	2 1/2"	" " "	6.00
703	" " "	8"	x	" " "	7.50
704	" " "	3 1/2"	4 1/2"	" " "	7.50
705	" " "	5 1/2"	2 1/2"	" " "	7.50
706	" " "	5 1/2"	4 1/2"	" " "	9.00

PHILADELPHIA INDUSTRIAL THERMOMETERS
SEPARABLE SOCKET CONNECTION

Bronze V-shape case, frame and glass front with separable socket. Stem 3½" including thread. Adapted for use on super-heaters, boilers, vats, stills, retorts, etc.; and pipe lines such as steam, water, brine, oil and other liquids.

Straight Form

No.	Scale Case	Socket	Price
242	7"	No. 700	\$18.50
272	9"	"	21.00
302	12"	"	25.00
243	7"	No. 701 or No. 702	20.50
273	9"	" "	23.00
303	12"	" "	27.00

Angle Form

No.	Scale Case	Socket	Price
252	7"	No. 700	\$20.50
282	9"	"	24.00
312	12"	"	28.00
253	7"	No. 701 or No. 702	22.50
283	9"	" "	26.00
313	12"	" "	30.00

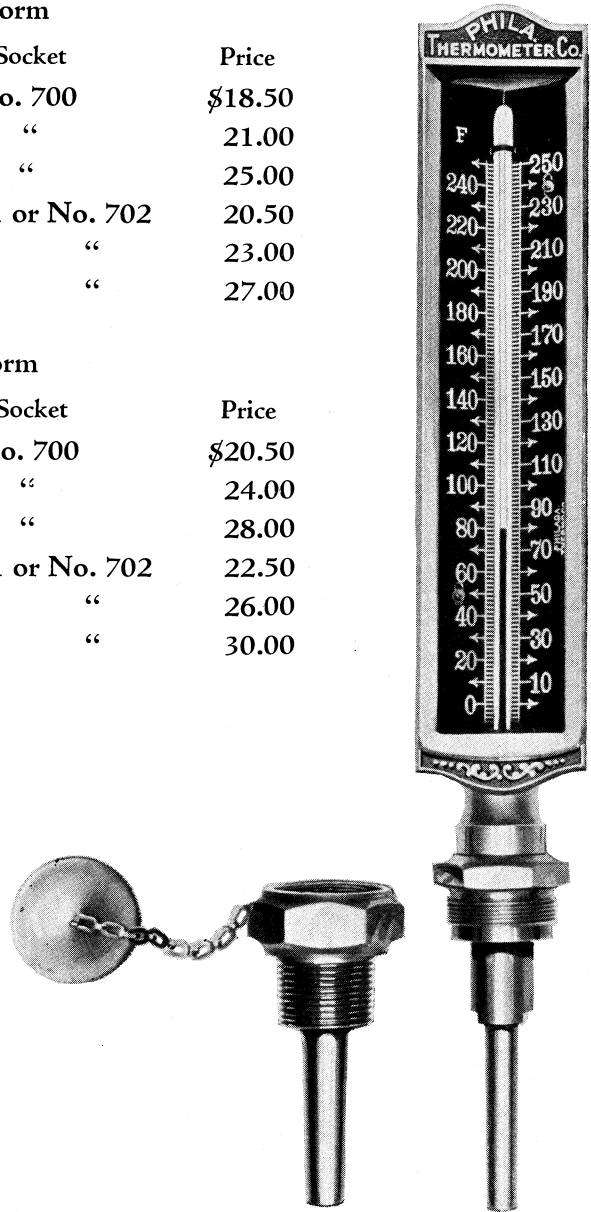
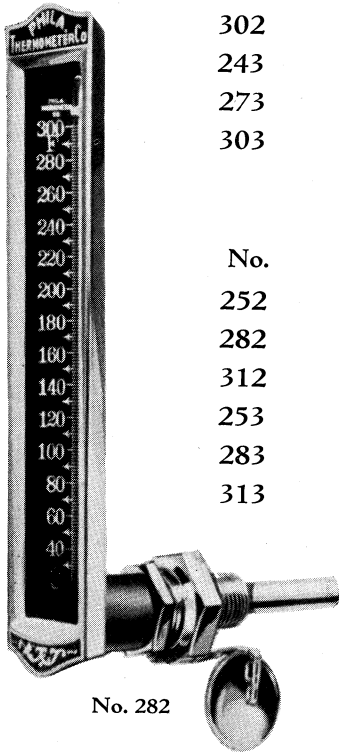

For sockets with greater stem length than those listed above add \$2.00 for each additional 3" or fraction thereof. Socket with ¾" S. P. T. connection will be supplied unless otherwise specified.

PHILADELPHIA INDUSTRIAL THERMOMETERS

UNION CONNECTION TYPE

Bronze V-shape case, frame and glass front with swivel nut and union connection. Stem $3\frac{1}{2}$ " including thread. The union connection is attached to the line and thermometer fastened by means of the swivel nut. This type of connection facilitates installation, eliminates all strains, and makes it unnecessary to turn the scale case, thereby insuring the proper position of the thermometer.

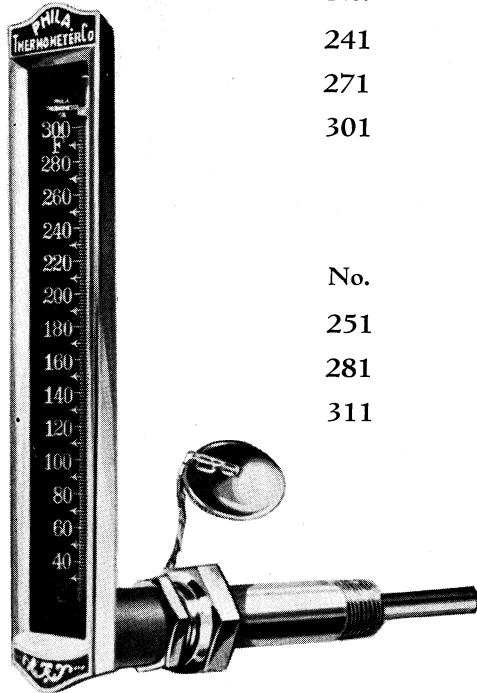

No. 281

Straight Form

No.	Scale Case	Price
241	7"	\$15.50
271	9"	18.00
301	12"	22.00

Angle Form

No.	Scale Case	Price
251	7"	\$17.50
281	9"	21.00
311	12"	25.00

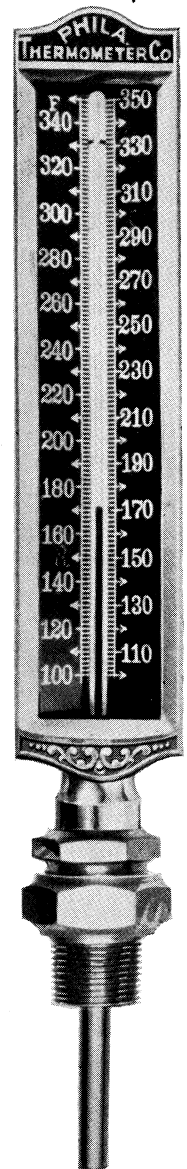

No. 271

$\frac{3}{4}$ " standard pipe thread furnished unless otherwise specified. For greater stem length add \$1.00 for each additional 3" or fraction thereof.

For union connection with $2\frac{1}{2}$ " extension neck (not including stem length) add \$2.00 to list price.

PHILADELPHIA INDUSTRIAL THERMOMETERS
FIXED THREAD TYPE

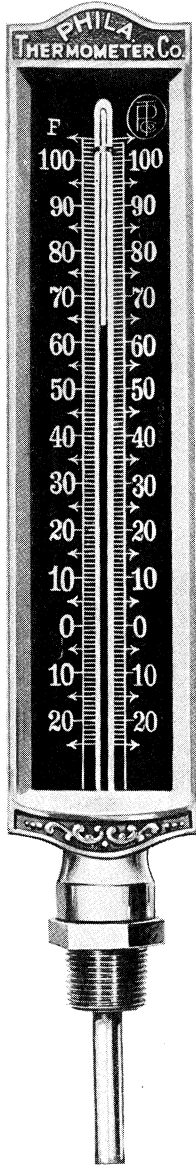

No. 270

Bronze V-shape case, frame and glass front with fixed thread connection. Stem 3 1/2" including thread. With this type of connection the hexagon nut and thread is permanently attached to the case and when installing, the scale case necessarily rotates with the nut. In tightening thermometer into position care should be taken to use a wrench on the wrench head of the fixed thread.

Straight Form

No.	Scale Case	Price
240	7"	\$12.50
270	9"	15.00
300	12"	19.00

Angle Form

No.	Scale Case	Price
250	7"	\$14.50
280	9"	18.00
310	12"	22.00

3/4" standard pipe thread furnished unless otherwise specified.

For greater stem length add \$1.00 for each additional 3" or fraction thereof.

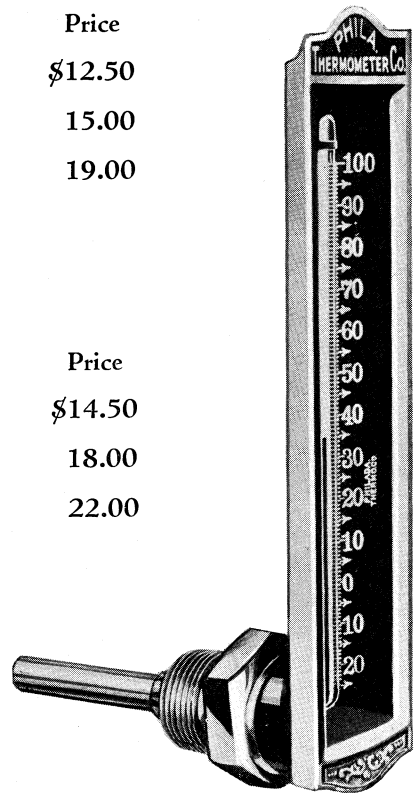

No. 280

PHILADELPHIA INDUSTRIAL THERMOMETERS
SIDE ANGLE TYPE

Bronze V-shape case, frame and glass front side angle form thermometers are used principally where it would be inconvenient to read the regular back angle form thermometer. They can be installed in a high or low position and the face of the thermometer can be inclined or reclined to come within the line of vision.

On the 7" and 9" scale case the hub (for stem connection) and case are of one solid casting. (No. 261.) On the 12" case a ball ell connection is used. (No. 322.) This type of connection is also furnished on all partial side angle form thermometers.

Furnished with the regular standard pipe thread connections and 3 1/2" stem including thread.

Separable Socket Connection				Union Connection		
No.	Scale Case	Socket No.	Price	No.	7" Case	Price each
262	7"	700	\$20.50	261	7" Case	\$17.50
292	9"	700	24.00	291	9" "	21.00
322	12"	700	29.50	321	12" "	26.50
263	7"	701 or 702	22.50	Fixed Thread Connection		
293	9"	701 or 702	26.00	260	7" Case	\$14.50
323	12"	701 or 702	31.50	290	9" "	18.00
				320	12" "	23.50

For Greater Stem Length

On fixed thread or union connection type } For each additional 3" or fraction thereof add \$1.00 to list price

On separable socket connection } For each additional 3" or fraction thereof add \$2.00 to list price

For union connection with 2 1/2" extension neck (Not including stem length) } Add \$2.00 to list price

Specify right or left side angle when ordering.
3/4" S. P. T. will be furnished unless otherwise specified.

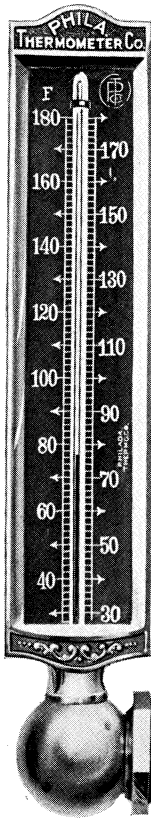

No. 322
Right Side Angle

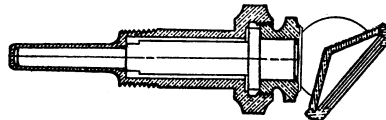
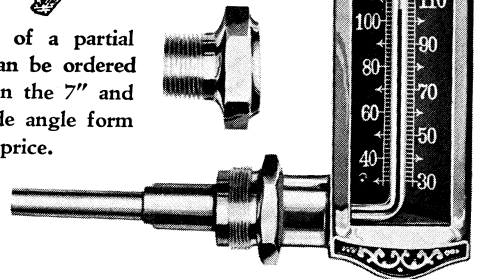

Diagram showing top view of a partial side angle thermometer. Can be ordered to face in any direction. On the 7" and 9" scale case, if a partial side angle form is desired, add \$1.50 to list price.



No. 261
Left Side Angle

PHILADELPHIA INDUSTRIAL THERMOMETERS

Reclined and Inclined Type

Bronze V-shape case, frame and glass front with scale case reclined or inclined is furnished with the regular standard pipe thread connections and stem length 3 1/2" including thread. The degree of the angle is constructed so as to permit convenient observation.

Separable Socket Connection

No.	Scale Case	Socket	Price
255	7"	700	\$20.50
285	9"	700	24.00
315	12"	700	28.00
256	7"	701 or 702	22.50
286	9"	" "	26.00
316	12"	" "	30.00

Union Connection

No.	Scale Case	Price
257	7"	\$17.50
287	9"	21.00
317	12"	25.00

Fixed Thread Connection

No.	Scale Case	Price
259	7"	\$14.50
289	9"	18.00
319	12"	22.00

For Greater Stem Length

On fixed thread or union connection type } For each additional 3" or fraction thereof add \$1.00 to list price
 On separable socket connection } For each additional 3" or fraction thereof add \$2.00 to list price
 For union connection with 2 1/2" extension neck (not including stem length) } Add \$2.00 to list price

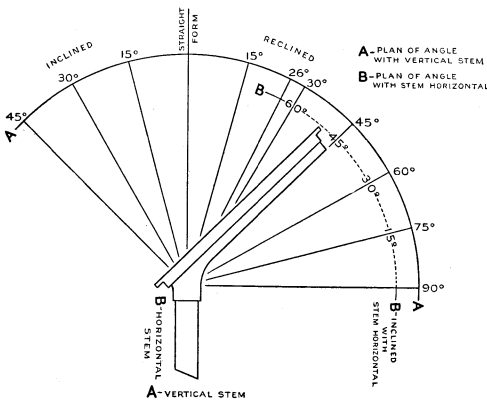

Plan of Angle for Reclined or Inclined Case Thermometers

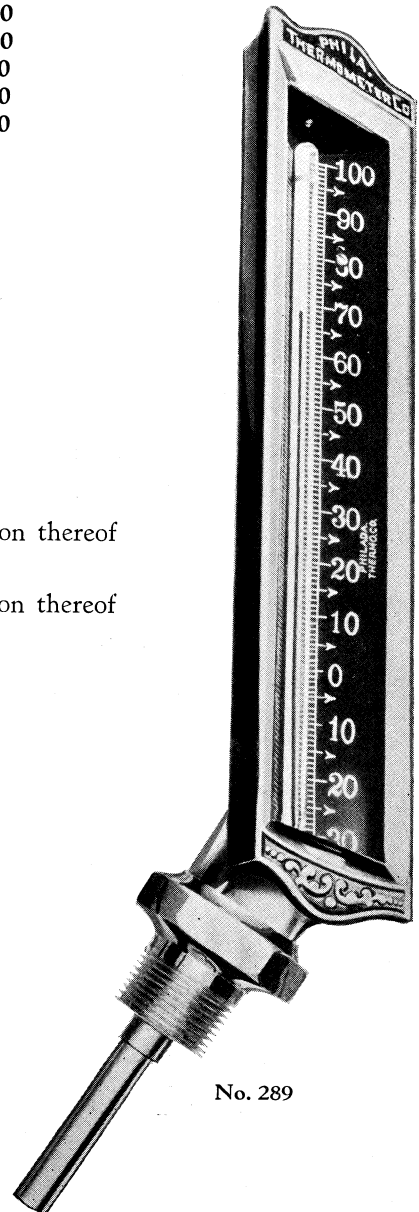

No. 289

PHILADELPHIA THERMO-STEAM & THERMO-VACUUM GAUGE THERMOMETERS

Super-Heated Steam Thermometers for High Velocity Steam

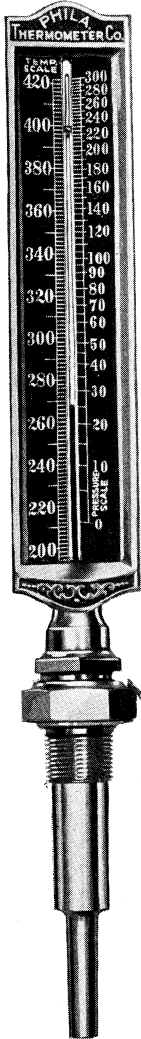

THERMO-STEAM GAUGE, bronze V-shape case, frame glass front, 3/4" separable socket. Stem 3 1/2" including thread.

High Pressure

Range 200°-420° F. with pressure scale 0-300 lbs.

Price Each

- No. 401—12" Case, str. form\$25.00
- No. 402—12" Case, str. form with No. 701 or 702 socket 27.00
- No. 403—12" Case, angle form 28.00
- No. 404—12" Case, angle form with No. 701 or 702 socket 30.00

Low Pressure

Range 200°-340° F. with pressure scale 0-100 lbs.

Price Each

- No. 405— 9" Case, str. form\$21.00
- No. 406—12" Case, str. form 25.00
- No. 407— 9" Case, angle form 24.00
- No. 408—12" Case, angle form 28.00

For Greater Stem Length

For each additional 3" or fraction thereof add \$2.00 to list price.

THERMO-VACUUM GAUGE (absolute pressure) 12" bronze V-shape case, frame glass front, with 1" S. P. T. union connection. Insulation between case and stem to prevent heat conduction. Range 30°-160° F with pressure scale (inches of mercury).

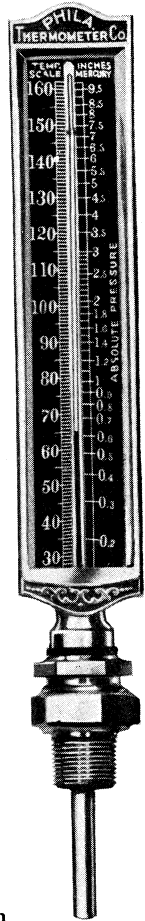

No. 402

No. 410

Price Each

- No. 410—Straight form\$25.00
- No. 411—Angle form 28.00

SUPER-HEATED STEAM THERMOMETERS for high temperature and high pressure steam. Range 300°-950° F. bronze V-shape case, frame glass front, with separable sockets machined from special alloy steel that will not be affected by the corrosive and erosive actions encountered on high velocity steam lines.

Socket has 1" S. P. T. with 2 1/2" extension neck. Tubes of magnifying lens front Borosilicate glass.

Price Each

- No. 415— 9" Case—Straight form \$28.00
- No. 416—12" Case—Straight form 32.00
- No. 417— 9" Case—Angle form 31.00
- No. 418—12" Case—Angle form 35.00

FOR GREATER STEM LENGTH

For each additional 3" or fraction thereof add \$3.00 to list price

PHILADELPHIA INDUSTRIAL
THERMOMETER FITTINGS

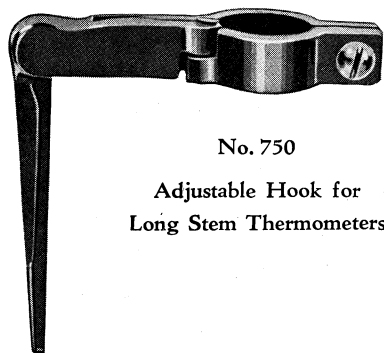

No. 750
Adjustable Hook for
Long Stem Thermometers

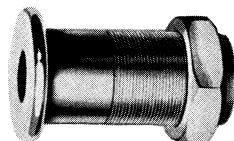

No. 770
Sanitary Wall Fitting

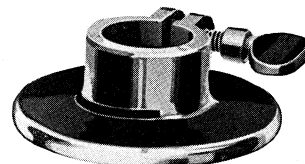

No. 755
Adjustable Flange

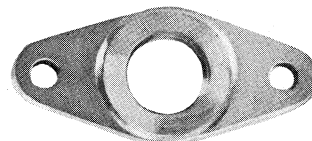

No. 756
Fixed Flange

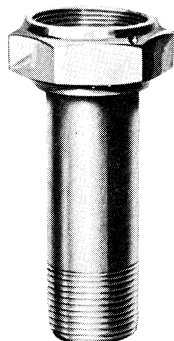

No. 765
Union Connection with
2 1/2" Extension Neck

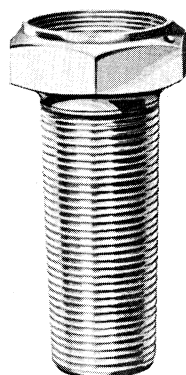

No. 768
Union Connection with
Wood Thread

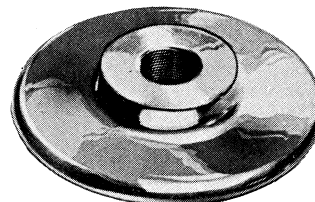

No. 757
Fixed Flange

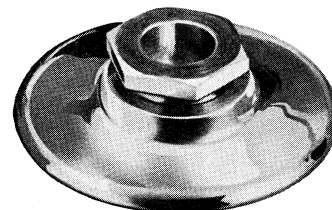

No. 758
Union Flange with Swivel Nut

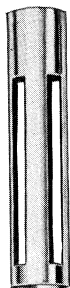

No. 752
Slotted
Bulb
Guard

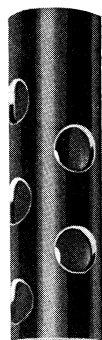

No. 751
Perforated
Bulb Guard

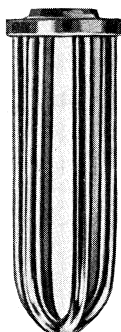

No. 753
Wire Strand
Basket Type
Guard

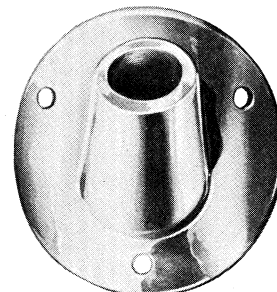

No. 759
Oblique Angle Concave Flange

PHILADELPHIA INDUSTRIAL THERMOMETERS FOR

Air Ducts—Dryers—Ovens, etc.

Bronze V-shape Case With Frame Glass Front

AIR DUCTS

Range 0°-160° F

Straight Form, 6" Stem

- | | |
|---|------------|
| | Price Each |
| No. 200— 9" Case with fixed flange* | \$15.00 |
| No. 201— 9" Case with union connection flange | 18.00 |
| No. 220—12" Case with fixed flange* | 19.00 |
| No. 221—12" Case with union connection flange | 22.00 |

Angle Form 6" Stem

- | | |
|---|------------|
| | Price Each |
| No. 202— 9" Case with fixed flange* | \$18.00 |
| No. 203— 9" Case with union connection flange | 21.00 |
| No. 222—12" Case with fixed flange* | 22.00 |
| No. 223—12" Case with union connection flange | 25.00 |

DRYERS—OVENS—ETC.

Stock Ranges 30°-240° F, 50°-300° F, 50°-400° F, 100°-500° F and 200°-750° F

Straight Form 4" Stem

- | | |
|--|------------|
| | Price Each |
| No. 205— 9" Case with fixed flange* | \$15.00 |
| No. 206— 9" Case with flange, locknut & washer | 16.00 |
| No. 207— 9" Case with union connection flange. | 18.00 |

Angle Form

- | | |
|--|---------|
| No. 210— 9" Case with fixed flange* | \$18.00 |
| No. 211— 9" Case with flange, locknut & washer | 19.00 |
| No. 212— 9" Case with union connection flange. | 21.00 |

Straight Form 4" Stem

- | | |
|--|---------|
| No. 225—12" Case with fixed flange* | \$19.00 |
| No. 226—12" Case with flange, locknut & washer | 20.00 |
| No. 227—12" Case with union connection flange. | 22.00 |

Angle Form

- | | |
|--|---------|
| No. 230—12" Case with fixed flange* | \$22.00 |
| No. 231—12" Case with flange, locknut & washer | 23.00 |
| No. 232—12" Case with union connection flange. | 25.00 |

Greater Stem Lengths

For each additional 6" or fraction thereof add \$2.00 to list price.

*A fixed thread connection S. P. T. will be furnished in place of fixed flange if specified.

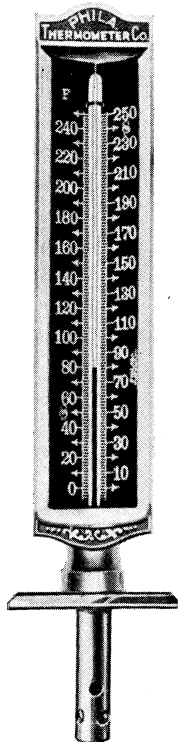

Fixed Flange

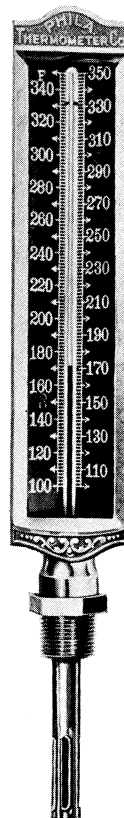

Fixed Thread Connection

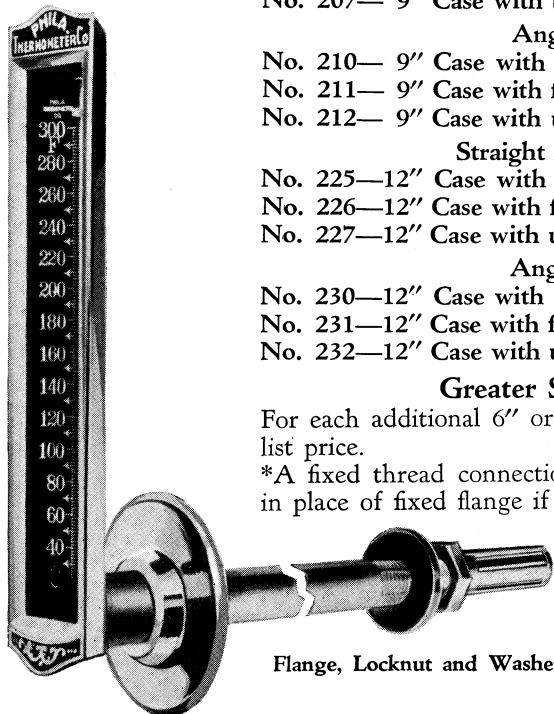

Flange, Locknut and Washer

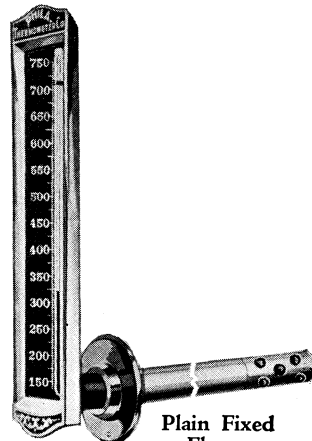

Plain Fixed Flange

**PHILADELPHIA STACK THERMOMETERS
FOR FLUE GASES**

12" V-shape case of bronze or aluminum, frame and glass front, steel stems with perforated guards and tubes of Borosilicate glass with magnifying lens front. Range 200°-1000° F.

Straight Form 12" Stem

- | | |
|---|-------------------|
| | Price Each |
| No. 396—With fixed thread or flange | \$25.00 |
| No. 397—With union connection flange* | 29.50 |

Angle Form 12" Stem

- | | |
|---|-------------------|
| | Price Each |
| No. 398—With fixed thread or flange | \$28.00 |
| No. 399—With union connection flange* | 32.50 |

For Greater Stem Length

Up to 36" stem length, each additional 6" or fraction thereof add \$1.00 to list.

Over 36" stem length, each additional 6" or fraction thereof add \$2.00 to list.

*If a 1" union hub is desired in place of union flange, deduct \$1.50 from list.

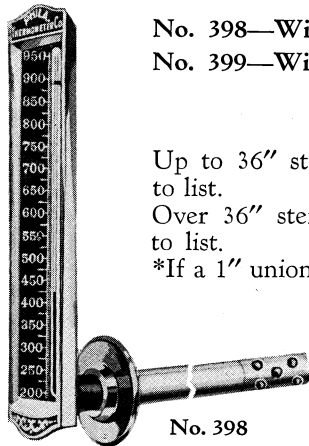

No. 398

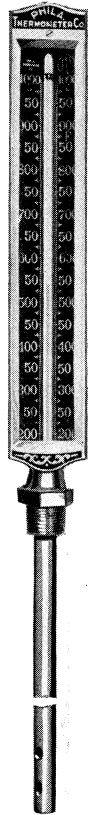

No. 396

DRYER THERMOMETERS FOR TEXTILE AND TOBACCO INDUSTRY

TIN CASE

10" angle black japanned tin case, perforated brass stem, red liquid or mercury filled magnifying lens front tubes and oxidized black scales with silvered lines and numbers. Range 40°-300° F.

- | | |
|----------------------|-------------------|
| | Price Doz. |
| No. 444—2½" stem ... | \$36.00 |
| No. 445—4½" stem ... | 36.00 |

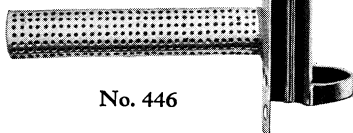

No. 446



IRON CASE

Angle flat iron case thermometers, with fenestrated brass bulb guards, 4½" stems, with screw holes top and bottom. Also made with locknut and washer. Furnished in two sizes, 6" and 10" case.

- | | |
|---|-------------------|
| | Price Each |
| No. 446—10" case | \$5.00 |
| No. 447—10" case, with locknut and washer | 6.00 |
| No. 448—6" case | 4.00 |
| No. 449—6" case, with locknut and washer | 5.00 |

NOTE—If brass case is desired, add \$1.00 to above list prices.

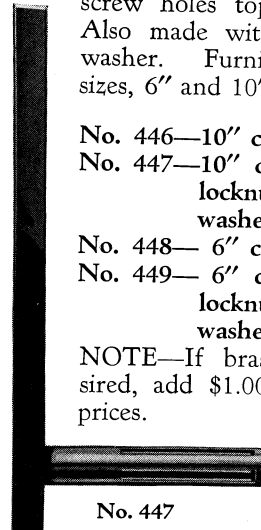

No. 447

PHILADELPHIA ROUND BRASS CASE THERMOMETERS

The cases are made of heavy gauge seamless brass tubing, 1" diameter with 7" scale opening, polished and lacquered. The various stem connections which are furnished make this type of thermometer adaptable to a wide range of uses.

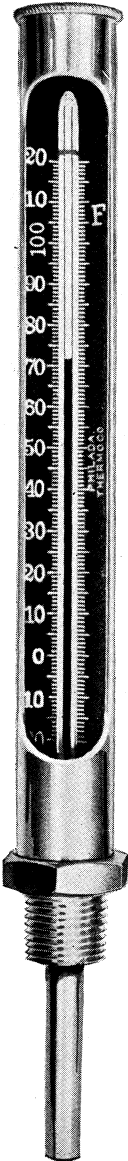

No. 20

**Standard Pipe Thread Connections
Stem Length Including Thread 3 1/2"**

Straight Form	Price Each
No. 20—8" Case with fixed thread	\$7.50
No. 21—8" Case with union connection	10.50
No. 22—8" Case with separable socket	13.50

Angle Form	Price Each
No. 30—8" Case with fixed thread	\$9.00
No. 31—8" Case with union connection	12.00
No. 32—8" Case with separable socket	15.00

**Wall Fittings for Air Ducts, Dryers, Ovens, Etc.
4" Stem**

Straight Form	Price Each
No. 40—8" Case with fixed flange	\$7.50
No. 41—8" Case with flange, locknut and washer	8.50
No. 42—8" Case with union connection flange	10.50

Angle Form	Price Each
No. 50—8" Case with fixed flange	\$9.00
No. 51—8" Case with flange, locknut and washer	10.00
No. 52—8" Case with union connection flange	12.00

For Greater Stem Lengths

On fixed thread, flange or union connection types	}	For each additional 3" or fraction thereof add \$1.00 to list
On separable socket connection	}	For each additional 3" or fraction thereof add \$2.00 to list
For union connection with 2 1/2" extension neck (not including stem length)	}	Add \$2.00 to list

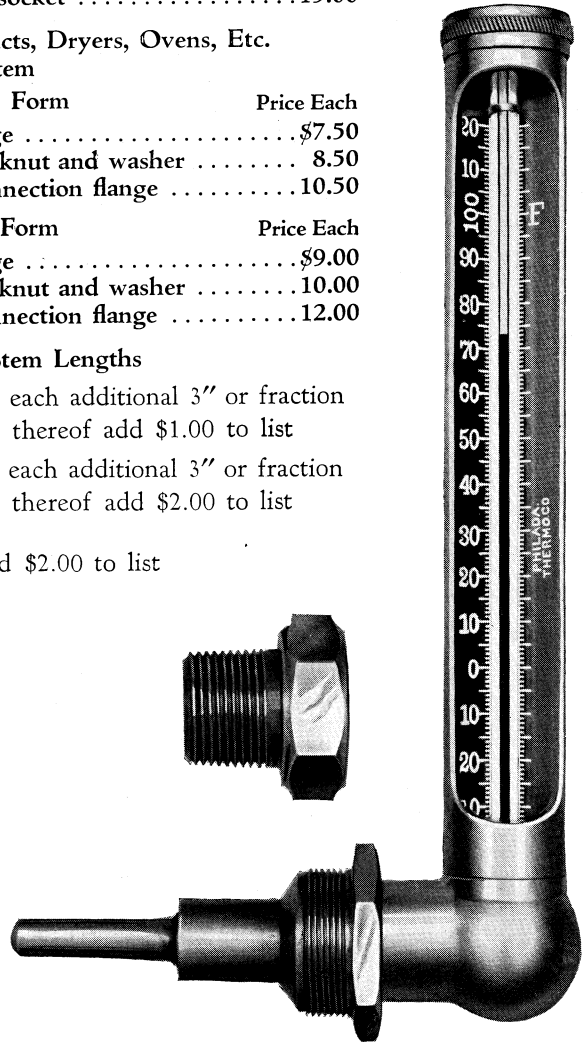

No. 35
Left Side Angle, Union Connection

Side angle forms carry the same list prices as the regular angle type.

Sliding cover for protection purposes, add \$1.00 to list price.

For thermometers with locknut and washer, specify the thickness of the wall.

On thermometers with standard pipe thread connections 3/4" S. P. T. will be furnished unless otherwise specified.

PHILADELPHIA OPEN FACE V-SHAPE IRON CASE THERMOMETERS

This type of thermometer is made with either a 7" or 9" scale case. The castings are carefully selected, machined and nickel-plated. Furnished with standard pipe thread connections and the various wall fittings.

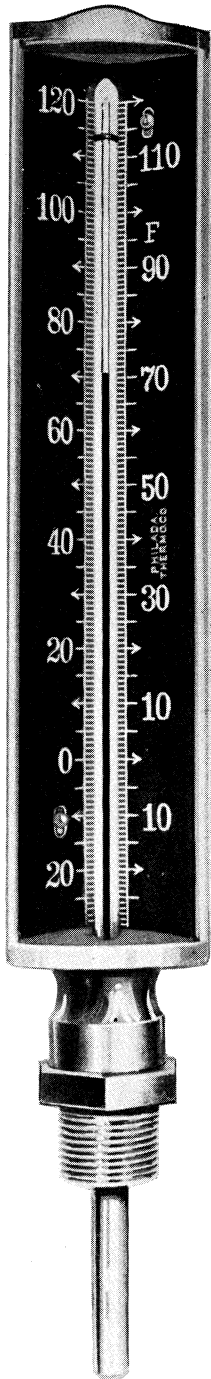

No. 90

Standard Pipe Thread Connections		Stem 3 1/2" Including Thread	Price Each
		Straight Form	
No. 60—7"	Case with fixed thread	\$7.00
No. 61—7"	Case with union connection	10.00
No. 62—7"	Case with separable socket	13.00
No. 90—9"	Case with fixed thread	9.00
No. 91—9"	Case with union connection	12.00
No. 92—9"	Case with separable socket	15.00
		Angle Form	
No. 70—7"	Case with fixed thread	\$8.50
No. 71—7"	Case with union connection	11.50
No. 72—7"	Case with separable socket	14.50
No. 100—9"	Case with fixed thread	10.50
No. 101—9"	Case with union connection	13.50
No. 102—9"	Case with separable socket	16.50

Wall Fittings for Dryers, Air Ducts, Ovens, Etc.

4" Perforated Stem		Price Each
		Straight Form
No. 63—7"	Case with fixed flange\$7.00
No. 64—7"	Case with flange, locknut and washer	.. 8.00
No. 65—7"	Case with union connection flange10.00
No. 93—9"	Case with fixed flange 9.00
No. 94—9"	Case with flange, locknut and washer	..10.00
No. 95—9"	Case with union connection flange12.00
		Angle Form
No. 73—7"	Case with fixed flange\$8.50
No. 74—7"	Case with flange, locknut and washer	.. 9.50
No. 75—7"	Case with union connection flange11.50
No. 103—9"	Case with fixed flange10.50
No. 104—9"	Case with flange, locknut, and washer	..11.50
No. 105—9"	Case with union connection flange13.50

For Greater Stem Lengths

On fixed thread, flange or union connection types } For each additional 3" or fraction thereof add \$1.00 to list

On separable socket connection } For each additional 3" or fraction thereof add \$2.00 to list

For union connection with 2 1/2" extension neck (Not including stem length) } Add \$2.00 to list

On thermometers with standard pipe thread connections 3/4" S. P. T. will be furnished unless otherwise specified. On cases made of bronze instead of iron add \$1.00 to list.

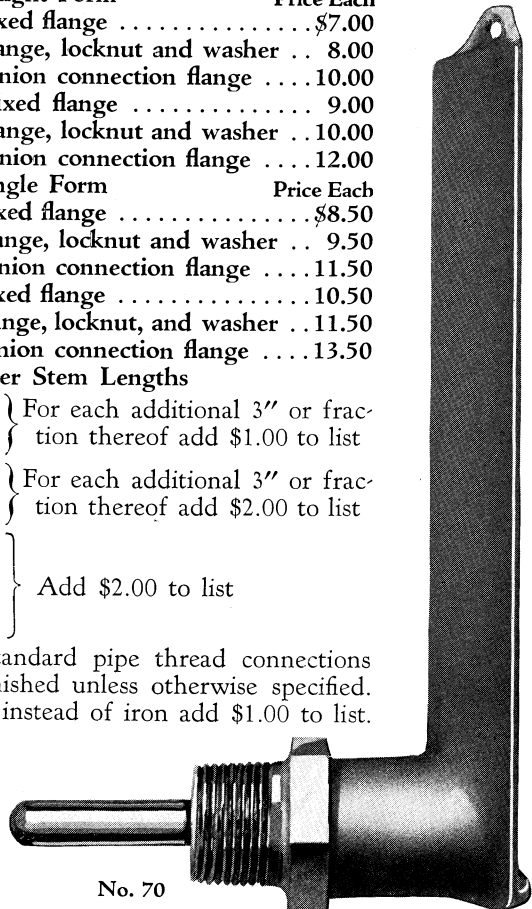

No. 70

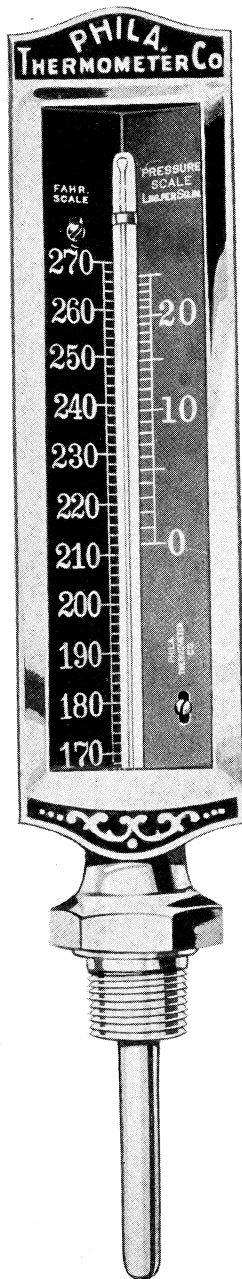

No. 244

PHILADELPHIA INDUSTRIAL THERMOMETERS

Retorts, Sterilizers, Condensers, Vulcanizers, etc.

Bronze V-shape case, $\frac{3}{4}$ " S. P. T., $3\frac{1}{2}$ " stem including thread

Scale Case	Price
No. 244—7" str. form fixed thread . . .	\$12.50
No. 245—7" str. form union conn. . . .	15.50
No. 246—7" str. form separable socket	18.50
No. 274—9" str. form fixed thread . . .	15.00
No. 275—9" str. form union conn. . . .	18.00
No. 276—9" str. form separable socket	21.00

(26° Reclined Angle)

No. 264—7" angle form fixed thread .	14.50
No. 265—7" angle form union conn. .	17.50
No. 266—7" angle form sep. socket ..	20.50
No. 294—9" angle form fixed thread .	18.00
No. 295—9" angle form union conn. .	21.00
No. 296—9" angle form sep. socket ..	24.00

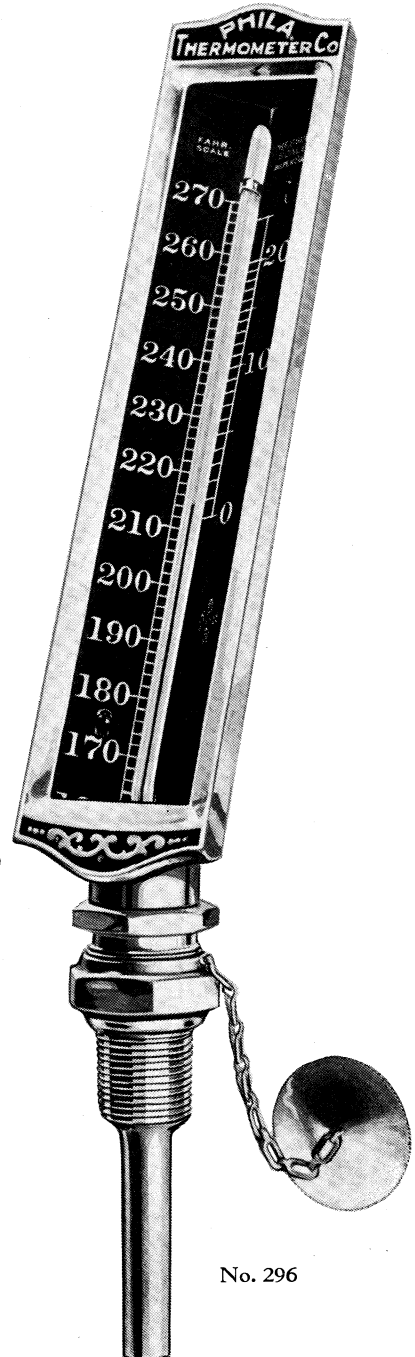

No. 296

Stock ranges 170—270° F with pressure scale. 200°-350° F with pressure scale for vulcanizers, etc.

NOTE—Also furnished in 90° back angle, left and right side forms.

PHILADELPHIA INDUSTRIAL THERMOMETERS

Pasteurizers, Vats, Coolers, Ripeners, Etc.

No. 375 Aluminum V-shape case, frame and glass front with wood handle at top, as shown, or stem handle with flange below scale case. Stem of nickel with non-corrosive steel bulb chamber.

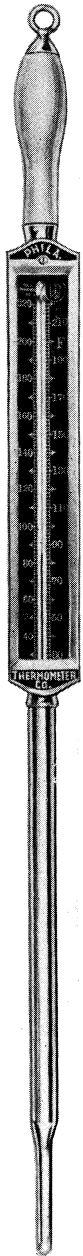

No. 375

			Price Each
No. 370—10" Scale case	24" stem	Range 30°-180° F	\$20.00
No. 371—10" Scale case	30" stem	Range 30°-180° F	22.00
No. 375—10" Scale case	14" stem	Range 30°-220° F	16.00
No. 376—10" Scale case	24" stem	Range 30—220° F	20.00
No. 377—10" Scale case	30" stem	Range 30°-220° F	22.00
No. 380— 7" Scale case	14" stem	Range 30°- 90° F	14.00
No. 381— 7" Scale case	24" stem	Range 30°- 90° F	18.00

No. 167 Seven-inch left side angle bronze V-shape case, frame and glass front, nickel-plated stem for sanitary wall fitting—I. A. M. D. specification—for walls 1 1/4" to 2 3/4" thick. Ranges to order.

(The following prices do not include fitting)

	Price Each
No. 165—90° back angle	\$20.00
No. 166—right side angle	20.00
No. 167—left side angle	20.00
No. 770—Sanitary wall fitting	3.50

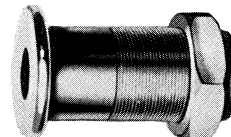

No. 770

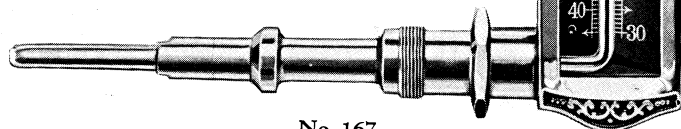

No. 167

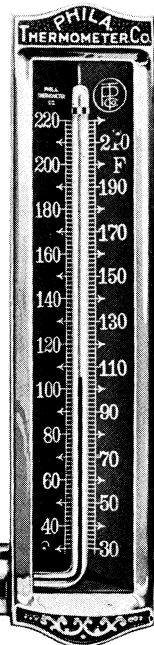

PHILADELPHIA COLD STORAGE ROOM THERMOMETERS

Bronze V-shape case, glass front with insulated brass stem and slotted bulb guard. Furnished complete with flange locknut and washer or union connection flange. Thermometers listed below have a stem length of approximately 13³/₄" and are suitable for walls 5" to 6" thick. Range -20°-120° F.

9" Bronze Case

	Price
No. 330—with flange, locknut and washer	\$21.50
No. 331—with union connection flange	23.50

12" Bronze Case

	Price
No. 335—with flange, locknut and washer	\$25.50
No. 336—with union connection flange	27.50

NOTE—In determining stem length measure thickness of wall and allow stem to project inside the room about 8 inches.

For greater stem lengths than listed above add \$2.00 for each 6 inches or fraction thereof.

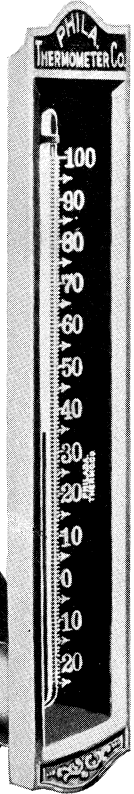
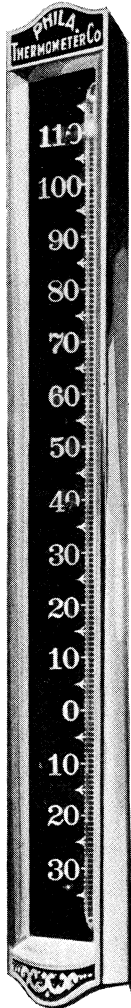

EXTRA HEAVY BULB GUARD (galvanized) as shown on No. 337 is made of 3/8" O. D. steel rod, riveted through a 4" flange. Overall length 10". Price\$6.00

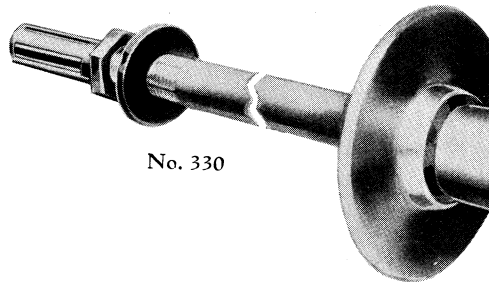

No. 330

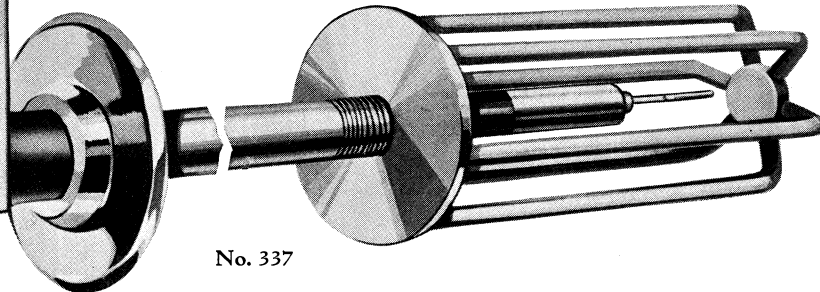

No. 337

PHILADELPHIA BRINE TANK THERMOMETERS

No. 342 (illustrated) is our 9" bronze V-shape case with glass front, reclined at a 45° angle with fixed flange and 36" stem.

These thermometers are carried in stock in the 9" and 12" size cases with fixed or adjustable flange with stem lengths 24", 30" and 36". Range - 30°-120° F.

The angle at which the case reclines is such as to enable a reading to be taken while one is in a standing position.

9" Bronze Case, 45° Angle Form

	Price
No. 340—24" Stem	\$19.00
No. 341—30" Stem	21.00
No. 342—36" Stem	23.00

12" Bronze Case, 45° Angle Form

	Price
No. 345—24" Stem	\$23.00
No. 346—30" Stem	25.00
No. 347—36" Stem	27.00

Straight Form Case

For 9" case deduct \$3.00 from above list prices

For 12" case deduct \$4.00 from above list prices

Adjustable flange furnished instead of fixed flange if specified.

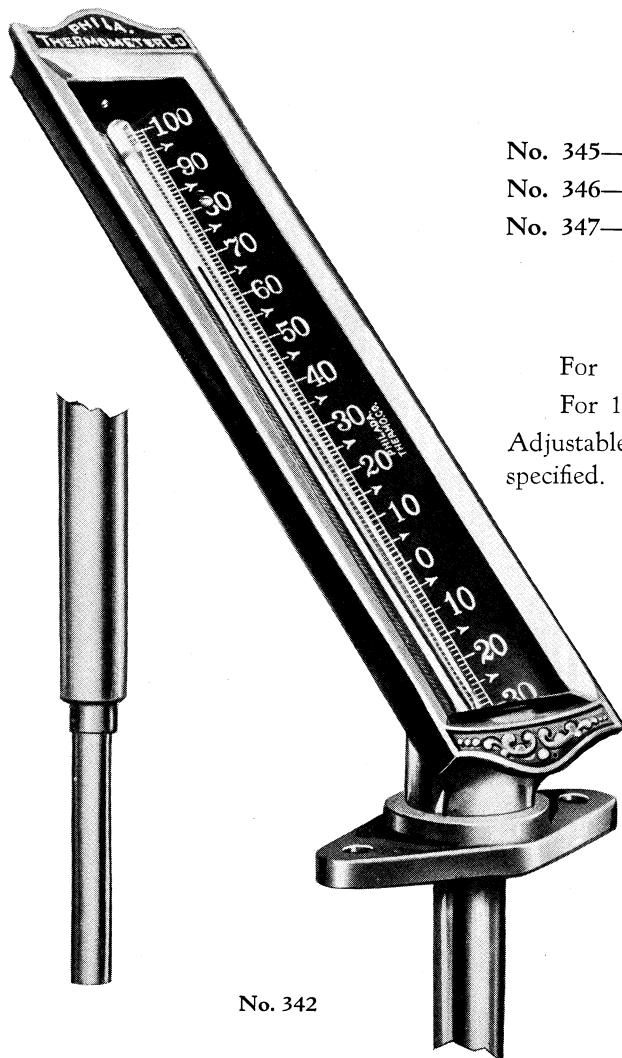

No. 342

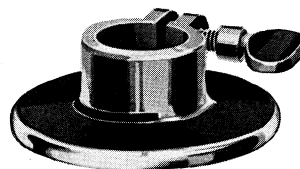

No. 755
Adjustable Flange

PHILADELPHIA LONG STEM KETTLE THERMOMETERS

For Varnish, Oils, Etc.

Scale cases of aluminum or bronze V-shape, with frames and glass covers.

The various stem lengths and stock ranges listed below make them adaptable to a wide range of applications.

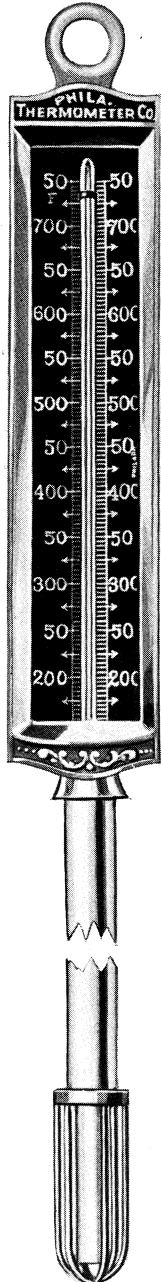

No. 358

12" Case Ring Top with Adjustable Hook on Stem

	Price
No. 354—12" stem	\$18.00
No. 355—18" stem	20.00
No. 356—24" stem	22.00
No. 357—30" stem	24.00
No. 358—36" stem	26.00
No. 359—48" stem	30.00
No. 360—60" stem	35.00
No. 361—72" stem	41.00
No. 362—84" stem	48.00

Standard Ranges	}	- 40°-120° F
		30°-180° F
		30°-240° F
		50°-400° F
		100°-500° F
		200°-750° F

In ordering specify { Purpose intended.
Working Range.
Average depth thermometer will be immersed.

10" Case Handle Top

	Price
No. 365—12" stem	\$16.00
No. 366—18" stem	18.00
No. 367—24" stem	20.00
No. 368—30" stem	22.00

Stock Ranges	}	- 20°-120° F
		30°-240° F
		200°-360° F
		200°-750° F

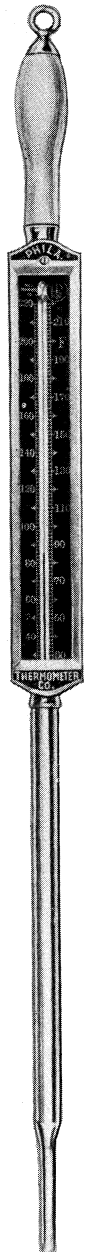

No. 366

PHILADELPHIA INDUSTRIAL THERMOMETERS

For Molten Metals

Stereotyping—Lead—Solder—Galvanizing—Etc.



No. 351



No. 533

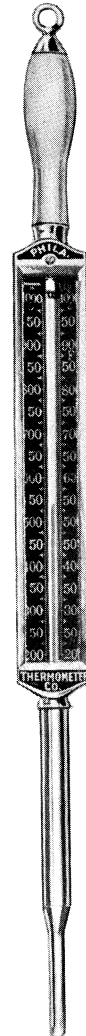

No. 374

	Price
No. 351—12" bronze case, frame and glass front with ring top. Stem 18" of cast iron pipe 1 1/4" O. D. Range 200°-1000° F	\$35.00
No. 374—10" aluminum case, glass front with hard wood handle. Stem 12" Range 200°-1000° F	20.00
No. 373—Same as above except calibrated 500°-950° F with 9" stem.	20.00
No. 533—Monotype thermometer consists of engraved stem thermometer mounted in armored case with wood handle. Approximately 18" overall. Range 400°-1000° F	9.00
No. 349—12" iron case, open face of V-shape design ring top with 24" stem. Range 200°-750° F	18.00
200°-950° F	23.00

PHILADELPHIA THERMOMETERS FOR
CONFECTIONERS AND BAKERS

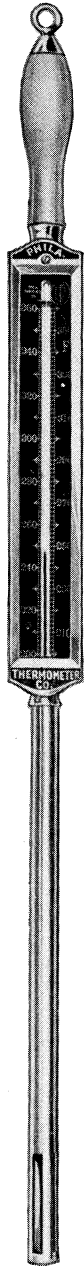

No. 382



No. 420



No. 1503

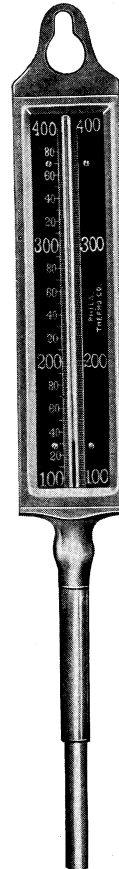

No. 385



No. 1001

No. 382—Confectioners Improved Boiling thermometer, 10" aluminum V-shape case, glass front, wood handle top, with 14" stem, and sanitary bulb guard. Complete with pulley and cord for suspension. Range 200°-360° Feach \$18.00

No. 385—Confectioner's thermometer, 7" aluminum V-shape case, glass front, with 5" stem. Ranges 100°-400° F and 200°-360° Feach \$12.00

No. 386—For dough testing, same as No. 385, except range, 50°-120° F .each \$12.00

For Fat Frying

No. 424—Copper case thermometer 12" length, graduated 50°-600° F, similar to No. 420doz. \$33.00

Copper case confectioner thermometers, magnifying lens front tubes, with cylindrical bulbs, mounted on silvered plated scales. Range 100°-400° F.

	Dozen
No. 420 —12" size	\$30.00
No. 421 —14" size	33.00
No. 423 —18" size	45.00

Chocolate and Dough Testing

No. 1503—Enclosed paper scale thermometer, 9" length, graduated 30°-120° Fdoz. \$18.00

Syrup Testing Hydrometer

No. 1001—Graduated 0°-50°, Baume, 60° Fdoz. \$18.00

PHILADELPHIA THERMOMETERS FOR BAKERS

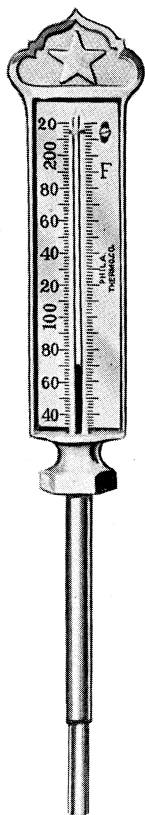

No. 389

BAKER'S DOUGH THERMOMETER

No. 379, 7" V-shape polished aluminum case, with glass front and handled top. 12" silver-plated brass stem, insulated to prevent heat conduction, with a long sensitive bulb chamber. Price\$18.00

SMALL DOUGH TEST THERMOMETER

No. 388, 5" flat brass case, nickel-plated, with 5" stem, same as No. 389, except range, 50°-120° F. Price\$7.50

ARMORED DOUGH THERMOMETER

No. 530, 12" engraved stem thermometer, graduated 50°-120° F, mounted in nickel-plated armored case. Price\$4.00



No. 530

STANDARD OVEN THERMOMETER

No. 350, 12" angle, V-shape iron case, with nickel-plated frame, glass front, 36" stem, range 200°-800° F. Priceeach \$20.00

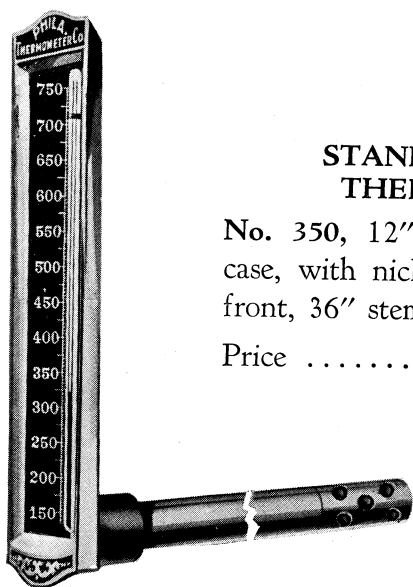

No. 350

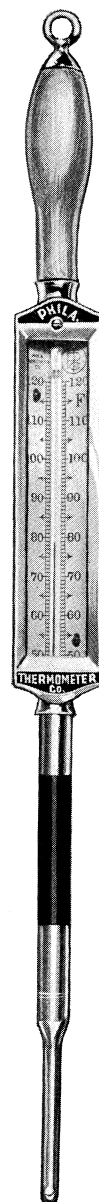

No. 379

PHILADELPHIA MIDGET, SHOWER BATH, HOT WATER, THERMOMETERS

Philadelphia feed water thermometers, for brine pipe, hot water and feed water systems. A high grade nickel-plated iron case thermometer, with individually calibrated scales, oxidized black with silvered lines and numbers, and heavy magnifying lens tubes. Fitted with 1/2" or 3/4" S. P. T. mercury wells.

Stock Ranges { - 20°-120° F
40°-260° F

Price

No. 1—Straight form\$2.50

No. 5—Angle form 3.00

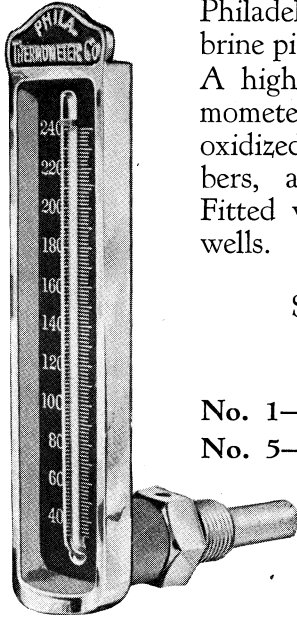

No. 5

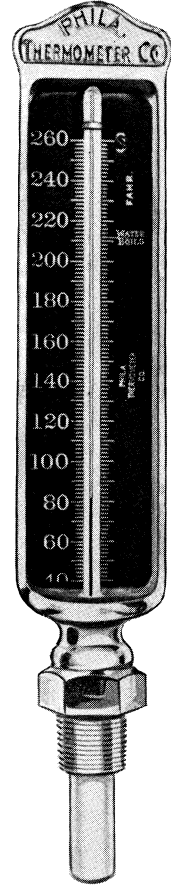

No. 1

Shower-Bath Thermometer

Nickel plated round brass case, 3/8" or 1/2" S. P. T. and 1" bulb chamber. Magnifying lens front tube, red liquid or mercury and 5" scale oxidized black with silvered lines and numbers. Ranges - 20°-120° F and 40°-220° F.

Price

No. 10—Straight form. \$5.00

No. 15—Angle form .. 6.00



No. 10

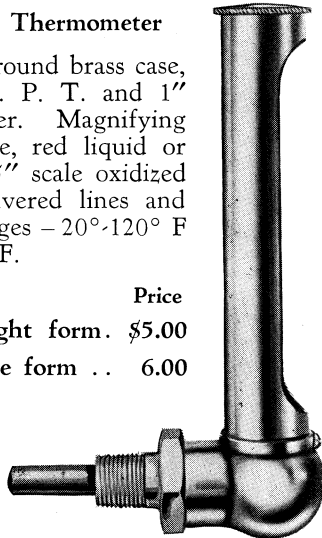

No. 15

Midget Thermometer

Nickel-plated bronze case, 3/8" S. P. T. 1" bulb chamber, with silvered or black oxidized scale, and magnifying lens front tube, mercury or red liquid. Stock ranges - 20°-120° F and 40°-220° F.

Price

No. 7—Straight form ... \$4.00

No. 8—Angle form ... 5.00

NOTE: Special midget thermometers listed on page 29.

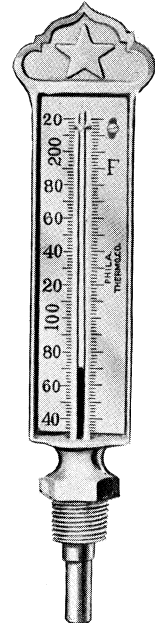

No. 7

PHILADELPHIA BAKELITE CASE THERMOMETERS

7" V-shape cases of bakelite, with open face or glass front, furnished with straight or angle stems, standard fittings, such as fixed thread, union connection and separable sockets. Range not exceeding 300° F. Stem length 3 1/2" including thread. Features of this case are such, that it will not corrode, rust, tarnish, frost over, or be affected by dilute acids, alkalis, etc., and will prevent heat conduction.

Open Face Bakelite Case

			Price
No. 60B	Str. 7" V case fixed thread	\$6.50
No. 61B	Str. 7" V case union connection	9.50
No. 62B	Str. 7" V case separable socket	12.50
	90°		
No. 70B	Angle 7" V case fixed thread	8.00
No. 71B	Angle 7" V case union connection	11.00
No. 72B	Angle 7" V case separable socket	14.00

Glass Front Bakelite Case

			Price
No. 240B	Str. 7" V case fixed thread	\$9.50
No. 241B	Str. 7" V case union connection	12.50
No. 242B	Str. 7" V case separable socket	15.50
	90°		
No. 250B	Angle 7" V case fixed thread	\$11.00
No. 251B	Angle 7" V case union connection	14.00
No. 252B	Angle 7" V case separable socket	17.00

3/4" S. P. T. will be furnished unless otherwise specified.

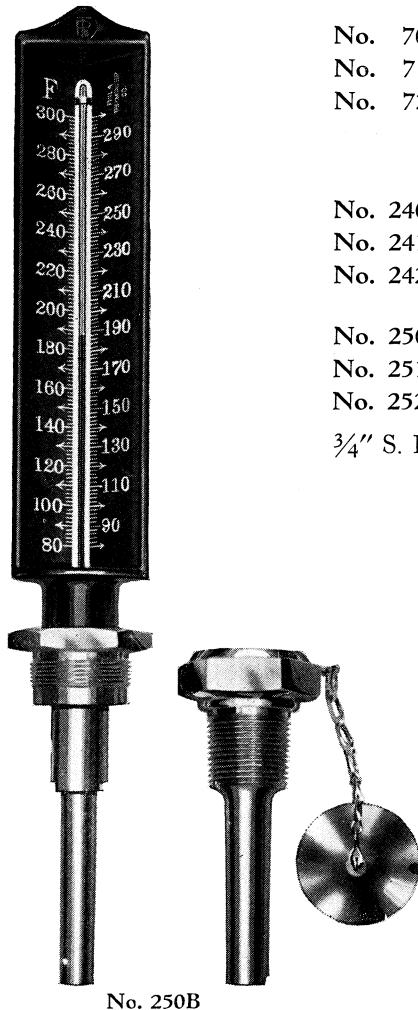

No. 250B

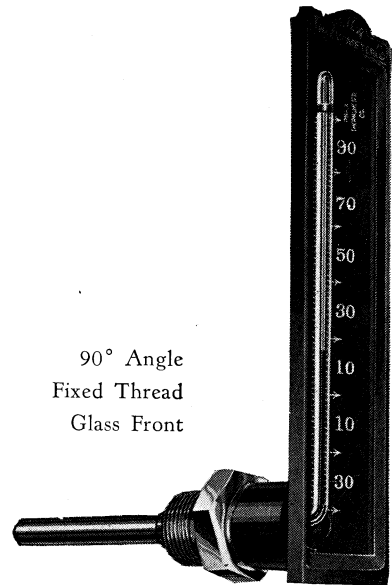

90° Angle
Fixed Thread
Glass Front

No. 62B

OTHER PHILADELPHIA PRODUCTS

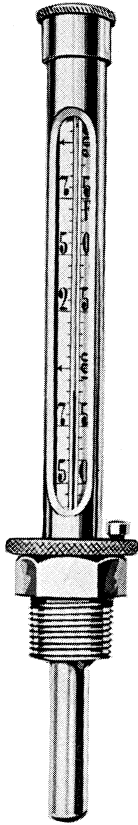

No. 541



No. 535

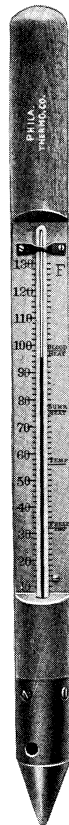

No. 539

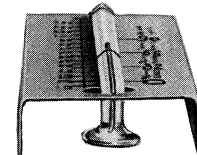
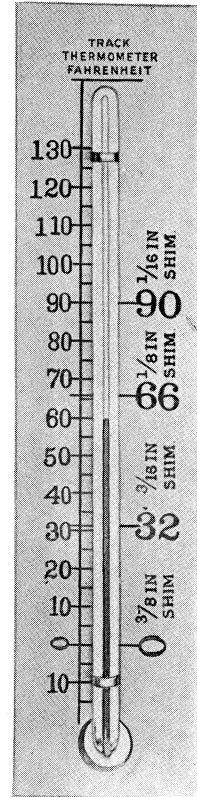

No. 537

No. 541—Diesel engine thermometer, submarine type, U. S. Navy specifications. Round brass case with lockwasher and special non-corrosive steel socket. Enclosed scale type thermometer is mounted in case with asbestos gaskets which act as shock absorbers. Price\$11.50

No. 535—Wax pot thermometer, nickel-plated round brass case with side hook and wood handle, lens tube mercury filled, and heavy brass scale, graduated 325°-450° F. Complete with vulcot fibre carrying case. Price\$10.00

No. 537—Track thermometer, angle tube with flat bulb mounted on flange scale. Used by many of the leading railroads, with the "Shim Scale" graduated to specifications. Range - 20°-140° F. Price\$5.00

Also used for surface or hot plate temperature tests with ranges up to 800° F. Prices on application.

No. 539—Hot bed thermometer, magnifying lens tube, mercury, silvered scale, black lines and numbers, mounted on hard wood back with perforated pointed bulb guard. Range 30°-140° F. Priceeach \$3.00

PHILADELPHIA THERMOMETERS FOR TRANSFORMERS

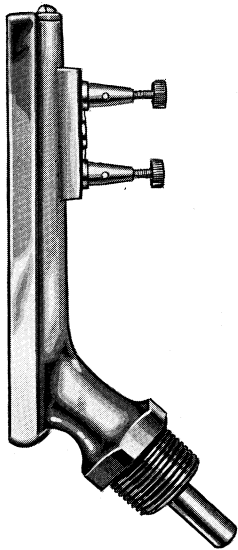

No. 125

Bronze V-shape case, glass front with fixed $\frac{3}{4}$ " , 1" or $\frac{1}{4}$ " standard pipe thread connection. Bulb chamber $1\frac{1}{2}$ ".

Plain type or with electric alarm feature, range 0° - 110° C.

Price Each

No. 120—5" case, plain type, 45° or 90° angle form, red liquid or mercury \$9.00

No. 121—6" case, plain type, 45° or 90° angle form, red liquid or mercury 10.00

No. 125—5" case, with electric alarm feature, mercury only 12.00

No. 126—6" case, with electric alarm feature, mercury only 13.00

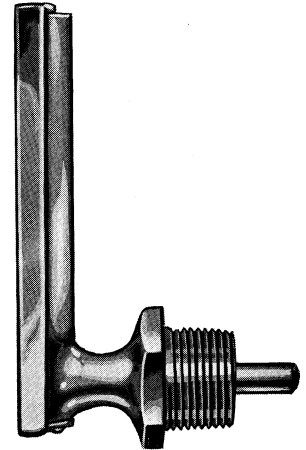
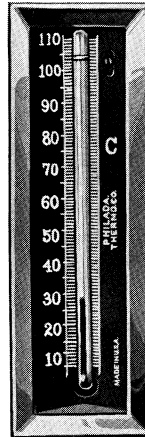

No. 120

Round brass case type, oxidized black, ruggedly constructed of heavy gauge seamless tubing, with $\frac{3}{8}$ " or $\frac{1}{2}$ " S. P. T. and $\frac{1}{2}$ " bulb chamber. Case has 5" scale opening. Range 10° - 110° C.

Price Each

No. 130—Str. form, red liquid or mercury \$7.00

No. 131—Angle form, red liquid or mercury 8.50

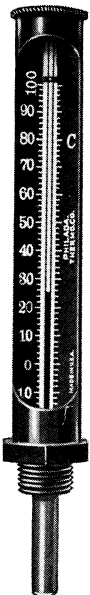

No. 130

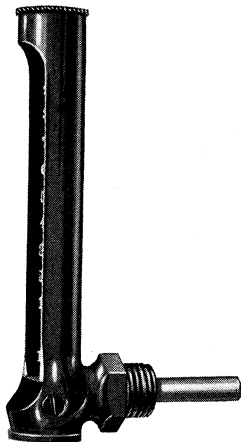

No. 131

Special Midget Thermometers

This type of thermometer in general construction is similar to No. 120 and consists of a 5" case V-shape of bronze, or nickel-plated iron, with glass front or open face design, $\frac{3}{8}$ " , $\frac{1}{2}$ " or $\frac{3}{4}$ " S. P. T. Bulb chamber $1\frac{1}{2}$ ".

Price Each

No. 140—Bronze case, glass front—Str. form . . . \$7.50

No. 141—Bronze case, glass front—Angle form . . . 9.00

No. 142—Bronze case, open face—Str. form 6.00

No. 143—Bronze case, open face—Angle form . . . 7.50

No. 144—N. P. iron case, open face—Str. form . . 5.00

No. 145—N. P. iron case, open face—Ang. form . . 6.50

PHILADELPHIA THERMOMETERS FOR GENERAL USE

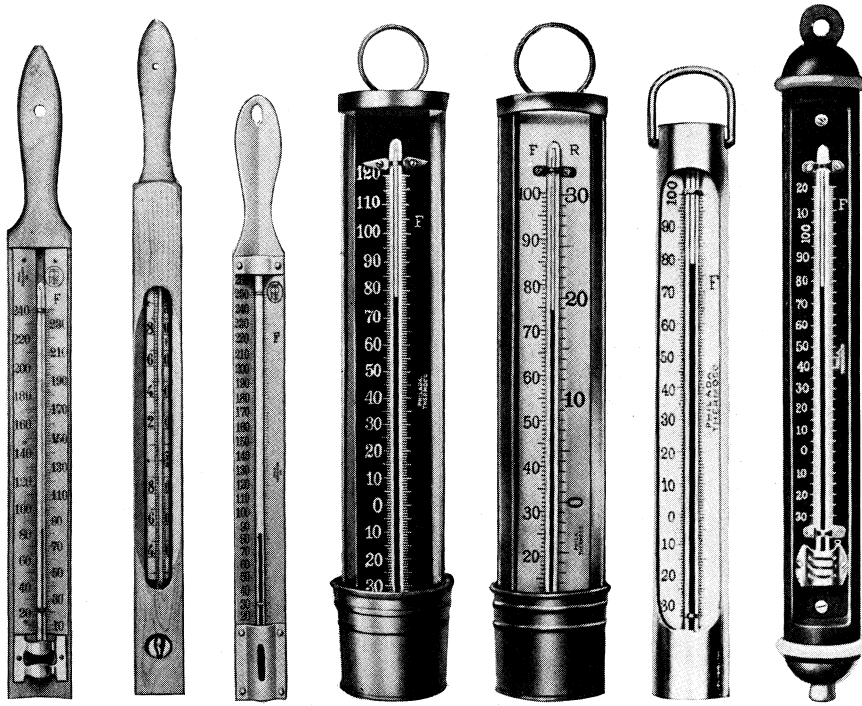

No. 561 No. 550 No. 556 No. 426 No. 426-C No. 428 No. 429

Price
Per Doz.

Price
Per Doz.

No. 561—Oak wood V-shape scale with handle top, silvered scale with black lines and numbers, magnifying lens front tubes, red liquid or mercury. Range 20°-240° F. \$30.00

No. 550—Enclosed paper scale type thermometer mounted in square wood frame with screw top handle. Red liquid or mercury. Range 20°-240° F 21.00

No. 556—Metal V-shape strop thermometer made of aluminum or brass, handle top, overall length 16". Magnifying lens front tubes, red liquid or mercury. Range 20°-240° F 30.00

No. 426—Copper cup case thermometer. In removing thermometer from tank a sufficient amount of liquid is retained in the cup surrounding bulb to enable a correct reading to be taken. Red liquid or mercury.

Stock ranges—20°-120° F—30°-240° F. 12" size 30.00

No. 425—Same as No. 426. 10" size ... 27.00

No. 426-C—Same as No. 425 and No. 426 except that it has a combination or a double scale F. & R. or F. & C. Add \$3.00 per doz. to list price.

No. 428—Ten-inch round brass case, 1" O. D. with closed bottom used for same purpose as No. 426. Red liquid or mercury tubes. Range -20°-120° F—30°-240° F . 48.00

No. 427—Same as above, except that the case is made of 1¼" tubing 60.00

No. 429—Shiphold thermometer, udylited iron case with rubber buffers on sides and bottom, allowing it to be lowered in inaccessible places. Red liquid tubes. Range -30°-120° F 42.00

PHILADELPHIA WALL THERMOMETERS

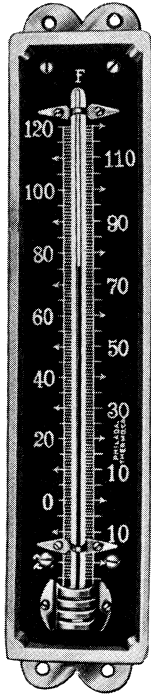

No. 451

No. 460—Twelve-inch V-shape hard wood back with oxidized black scale, silvered lines and numbers. Range - 20° 100° F. Red liquid or mercury and - 10°-70° F mercury only. Priceper doz. \$21.00

Iron Case Wall Thermometers

Heavy nickel-plated iron case with lugs for fastening to wall. Oxidized black scale with silvered lines and numbers. Magnifying lens front tubes, red liquid or mercury. Range - 20°-120° F.

N. P. Iron Case

	Price Per Doz.
No. 450— 8" size	\$24.00
No. 451—10" size	30.00
No. 452—12" size	36.00

Polished Brass Case

No. 453— 8" size	\$36.00
No. 454—10" size	42.00
No. 455—12" size	48.00

Copper Case and Black Japanned Tin Case
(Standard Grade)

These thermometers are furnished with either a copper or black japanned tin case of heavy material and durable construction. The scales are individually calibrated for each tube and are finished black with silver lines and numbers or silver with black lines and numbers.

Heavy magnifying lens front tubes, mercury or red liquid. Stock ranges - 20°-120° F, 0°-220° F, 30°-260° F.

Copper Case

No. 430— 8" size	\$21.00
No. 431—10" size	24.00
No. 432—12" size	27.00

Tin Case

No. 440— 8" size	\$15.00
No. 441—10" size	18.00
No. 442—12" size	21.00

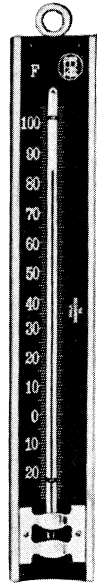

No. 460

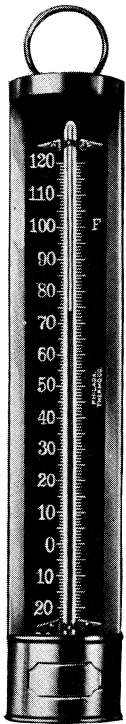

No. 432

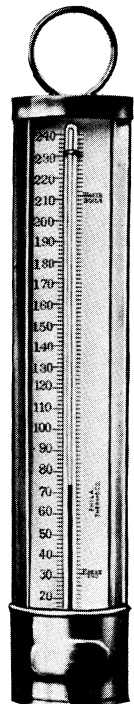

No. 442

PHILADELPHIA WET AND DRY BULB THERMOMETERS

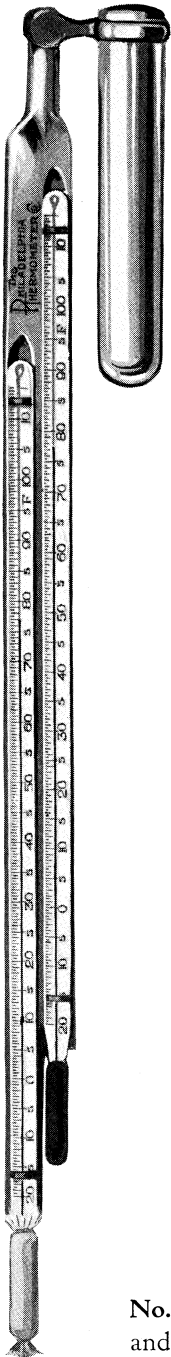

No. 495

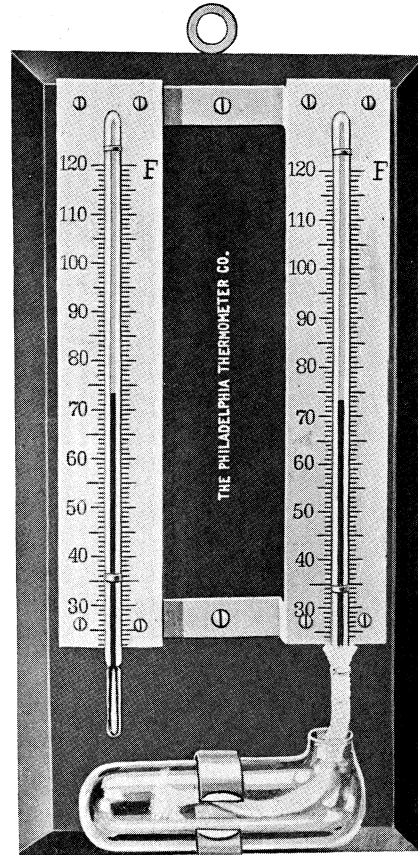

No. 490

No. 490—Mason's form Hygrometer, BEST GRADE, consists of the wet and dry bulb thermometers, mounted on a 9" x 4³/₄" mahogany or cherry finish hard wood back. Lens front, mercury filled tubes with cylindrical bulbs. Range 20°-120° F in 1 deg. div.—30°-220° F in 2 deg. div.

Priceeach \$5.00

No. 491—Similar to No. 490, except tubes have round bulbs and are filled with red liquid, mounted on back 8" x 3³/₄". Priceeach \$3.50

Sling Psychrometer

No. 495—Consists of two extra quality engraved stem thermometers (wet and dry bulb) mounted on aluminum back.

A hinge type connection is provided between the back and the aluminum handle. Ranges 0°-110° F in 1/2 degrees and 30°-200° F in 1 deg. div. Complete with copper carrying case. Priceeach \$11.00

PHILADELPHIA SPECIALTIES

No. 493—The **HYGROMETER** consists of a red liquid thermometer (dry bulb) and a blue liquid thermometer (wet bulb) mounted on a heavy brass plate, rich gold finish with black lines and figures, combined with humidity chart in revolving cylinder and sliding pointer which is placed conveniently between the two thermometers. These in conjunction with the water well are assembled neatly and compactly on a handsome mahogany finish wood back, complete with hanger for fastening to wall. The red liquid tube (dry bulb) indicates the room temperature, while the blue liquid tube (wet bulb) has a wick covering the bulb which draws up the water from the water jar and as evaporation takes place the bulb is cooled off accordingly. The difference in degrees between the red tube and blue tube when compared on revolving chart gives you the percentage of moisture, commonly known as relative humidity. After reading has been observed the chart and sliding pointer should be left "set" until next reading to indicate the change of conditions. Price\$7.50

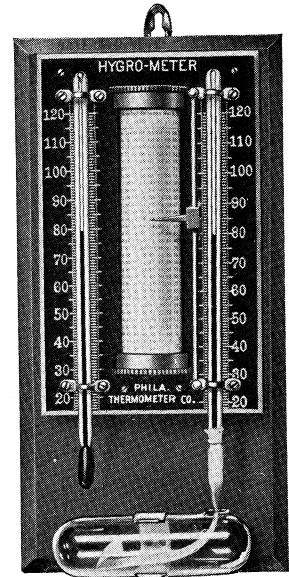

No. 493

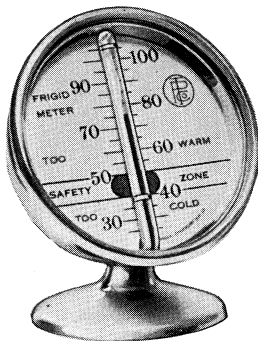

No. 571

Refrigerator Thermometer

No. 571—Frigid-meter. Red liquid, magnifying lens front tube, mounted on white scale with black lines and numbers. A signal, colored green, is provided in safety zone between the temperature of 40° and 50° F which is commonly accepted as the correct temperature for household refrigerators. The lettering "too warm" and "too cold" is stamped in red. Encased in nickel-plated brass case with glass front. Price\$2.50

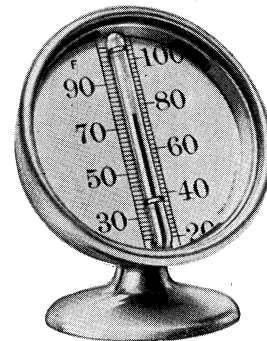

No. 572

Desk Thermometer

No. 572—Red liquid, magnifying lens front tube, mounted on gold-finish scale, encased in a highly polished and lacquered brass case with glass front. The bases are of composition and come in a variety of beautiful mottled colors. Price ...\$2.50

PHILADELPHIA CABINET THERMOMETERS

(Extra Quality)

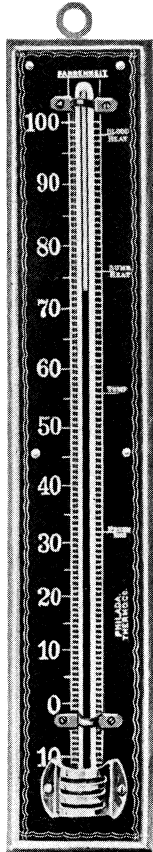

No. 827

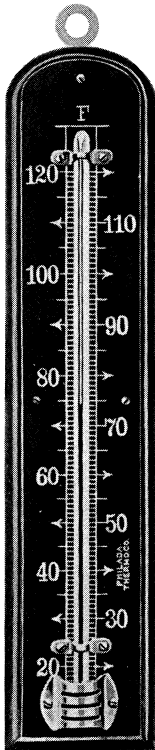

No. 829

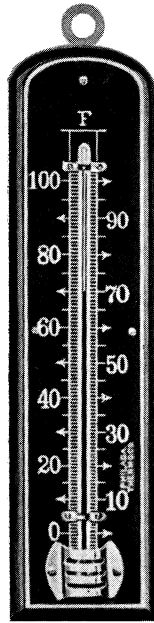

No. 831

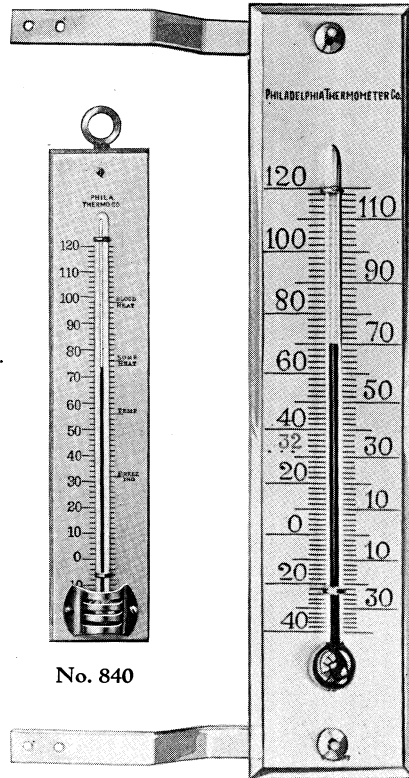

No. 850

No. 827—Magnifying lens front tube, red liquid or mercury, with black oxidized scale and silvered lines and numbers, or silvered scale with black lines and numbers, mounted on Oakwood back. Range approximately 20°-120° F.

	Price Per Doz.
No. 825— 6"	\$21.00
No. 826— 8"	24.00
No. 827—10"	27.00

No. 829—Similar to above, except mounted on mahogany back.	
No. 828— 6"	\$21.00
No. 829— 8"	24.00
No. 830—10"	27.00

No. 840—Plain 8" hard wood back wall thermometer for general use. Silvered scale, black lines and numbers. Red liquid tube. Range 0°-120° F. Priceper doz. \$18.00

No. 831—Mahogany back with bevel edge scale.

	Price Per Doz.
No. 831— 6"	\$24.00
No. 832— 8"	27.00
No. 833—10"	30.00

Window Thermometers

No. 850—Lens front blue liquid tube, mounted on 10" plate glass scale with beveled edge. Imported especially for us and guaranteed to be accurate. Priceper doz. \$30.00

Six's thermometer, (not illustrated) mounted on plate glass scale with beveled edge.

No. 851— 8"	\$60.00
No. 852—10"	72.00

PHILADELPHIA MAXIMUM AND MINIMUM THERMOMETERS

SELF-REGISTERING (Six's Type)

This type of instrument is used for indicating the prevailing temperature and registering the highest and lowest temperature to which it is subjected. The registering feature consists of two steel indexes in the spirit-filled bores and are moved by the mercury column which fluctuates by the expansion and contraction of the creosote-filled bulb.

Before using this instrument the indexes should be drawn down the bore with a magnet until they touch the mercury column.

A magnet is furnished with each instrument.

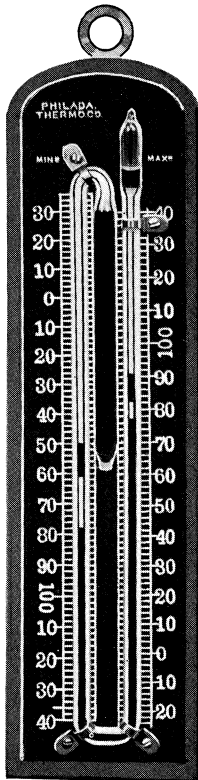

No. 480

Mounted on Mahogany Wood Back

	Price Each
No. 480— 8" size	\$5.00
No. 481—10" size	5.50

Mounted in Protecting Case
Copper Case

	Price Each
No. 486— 8" size	\$5.50
No. 487—10" size	6.00

Black Japanned Tin Case

	Price Each
No. 483— 8" size	\$5.00
No. 484—10" size	5.50

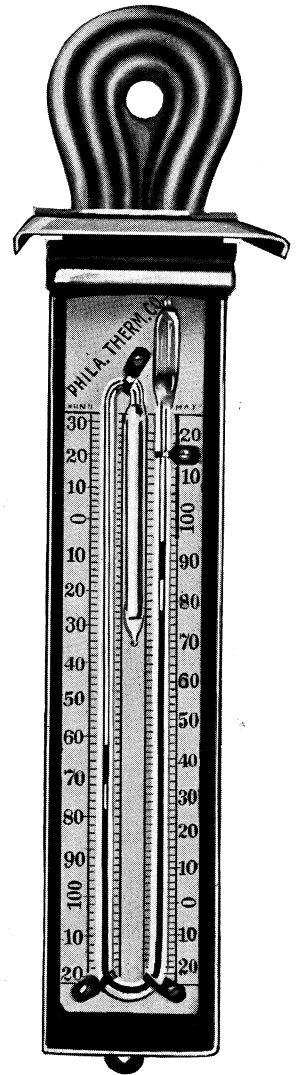

No. 486

OTHER PHILADELPHIA PRODUCTS

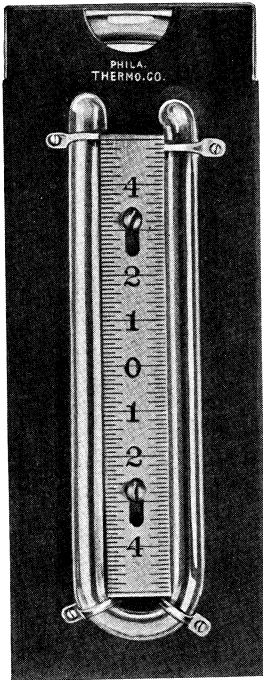

Front View
No. 498

No. 498—Miners water gauge, glass “U” tube mounted on wood back with spirit level and brass nipple extending through back. Plain type. Price\$4.50

No. 499—Same as No. 498 except with rack and pinion for zero adjustment. Price\$6.00

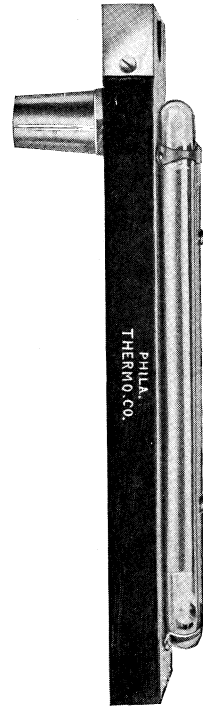

Side View

Salinometer for Sea Water

No. 1292—Salinometer thermometer, for use with salinometer pot, graduated 120°-220° F in 2° div. with special marks at 190°, 200° and 210° F with spring clip on back. Price\$2.50

No. 1291—Salinometer hydrometer “blow scale” for marine steam boiler water, graduated 0°-5/32 in 1/4°. Price ...\$1.50

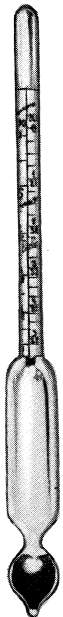

No. 1291

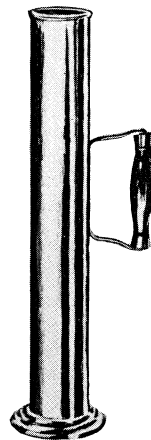

No. 1293

No. 1293 — Salinometer pot, for use with hydrometer and thermometer. Price\$5.50

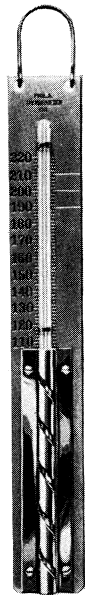

No. 1292



The
**PHILADELPHIA
THERMOMETER
COMPANY**

❖
Etched Stem Thermometers
Armor Case and Pocket
Case Thermometers
Paper and Porcelain
Scale Thermometers
Hydrometers
❖

The etched stem thermometers listed herein are made with extreme care, are thoroughly annealed to insure constancy and carefully calibrated for accuracy. They are rigidly inspected before leaving our factory, and are absolutely guaranteed as to quality.

A limited number of instruments with Bureau of Standard certificates carried in stock. Prices based on actual cost of certificate plus a small additional charge to take care of packing, transportation charges, etc., to the Bureau and return.

All hydrometers have hand written individually calibrated scales.

THE PHILADELPHIA THERMOMETER COMPANY

ENGRAVED STEM THERMOMETERS

Extra Quality

Fahrenheit Range	Div.	Length	No.	Price Each
- 20°-120°	1°	12"	2200	\$3.00
- 20°-120°	1/5°	18"	2201	7.50
- 20°-120°	1/10°	24"	2202	12.00
20°-220°	1°	12"	2203	3.00
20°-220°	1/2°	16"	2204	6.00
20°-220°	1/5°	24"	2205	12.00
30°-300°	1°	14"	2206	4.50
30°-400°	1°	14"	2207	6.00
30°-500°	1°	16"	2208	7.50
30°-600°	1°	18"	2209	9.00
30°-750°	2°	18"	2210	9.00
30°-950°	2°	18"	2211	12.00

Centigrade Range	Div.	Length mm	No.	Price Each
- 10°- 50°	1/5°	300	2225	\$4.50
- 10°- 50°	1/10°	350	2226	6.00
- 10°-110°	1°	300	2227	3.00
- 10°-110°	1/2°	300	2228	4.50
- 10°-110°	1/5°	400	2229	7.50
- 5°-105°	1/10°	600	2230	12.00
- 5°-150°	1°	300	2231	4.50
- 5°-150°	1/5°	450	2232	9.00
- 5°-200°	1°	350	2233	6.00
- 5°-200°	1/5°	600	2234	12.00
- 5°-250°	1°	350	2235	6.00
- 5°-250°	1/2°	400	2236	7.50
- 5°-360°	1°	400	2237	9.00
- 5°-360°	1/2°	500	2238	12.00
- 5°-525°	1°	450	2239	12.00

Standard Grade

Fahrenheit Range	Div.	Length	No.	Price Per Doz.
- 20°-120°	1°	6"	2000	\$16.20
20°-220°	2°	6"	2001	16.20
- 20°-120°	1°	12"	2002	18.00
20°-220°	2°	12"	2003	18.00
30°-300°	2°	12"	2004	21.00
30°-400°	2°	12"	2005	24.00
30°-500°	2°	12"	2006	27.00
30°-600°	2°	12"	2007	30.00
30°-750°	2°	15"	2008	48.00
30°-950°	5°	16"	2009	60.00

Centigrade Range	Div.	Length mm	No.	Price Per Doz.
- 10°- 50°	1°	150	2025	\$16.20
- 10°-100°	1°	150	2026	16.20
- 10°- 50°	1°	300	2027	18.00
- 10°-110°	1°	300	2028	18.00
- 10°-150°	1°	300	2029	21.00
- 10°-200°	2°	300	2030	24.00
- 10°-250°	2°	300	2031	27.00
- 10°-300°	2°	300	2032	30.00
- 10°-360°	2°	300	2033	36.00
- 10°-400°	2°	350	2034	48.00
- 10°-525°	2°	400	2035	60.00

Red Liquid Engraved Stem Thermometers (Non-fading Liquid)

Fahrenheit Range	Div.	Length	No.	Price Per Doz.
- 20°-120° F	1°	6"	2400	\$16.20
20°-220° F	2°	6"	2401	16.20
- 20°-120° F	1°	12"	2402	18.00
20°-220° F	2°	12"	2403	18.00
20°-300° F	2°	12"	2404	21.00

Centigrade Range	Div.	Length mm	No.	Price Per Doz.
- 10°- 50° C	1°	150	2410	\$16.20
- 10°-100° C	2°	150	2411	16.20
- 10°- 50° C	1°	300	2412	18.00
- 10°-100° C	2°	300	2413	18.00
- 10°-150° C	2°	300	2414	21.00

No. 2226

No. 2004

No. 2211

STANDARD GRADE ENGRAVED STEM THERMOMETERS
IN ARMORED CASE

Fahrenheit Scale

No.	Range	Length	Div.	Price Each
2500	- 20°-120°	6"	1°	\$3.10
2501	20°-220°	6"	2°	3.10
2502	- 20°-120°	12"	1°	3.50
2503	20°-220°	12"	2°	3.50
2504	30°-300°	12"	2°	3.75
2505	30°-400°	12"	2°	4.00
2506	30°-500°	12"	2°	4.25
2507	30°-600°	12"	2°	4.50
2508	30°-750°	15"	2°	6.25
2509	30°-950°	16"	5°	7.35

Centigrade Scale

No.	Range	Length	Div.	Price Each
2550	- 10°- 50°	150 mm	1°	\$3.10
2551	- 10°-100°	150 mm	1°	3.10
2552	- 10°- 50°	300 mm	1°	3.50
2553	- 10°-100°	300 mm	1°	3.50
2554	- 10°-150°	300 mm	1°	3.75
2555	- 10°-200°	300 mm	2°	4.00
2556	- 10°-250°	300 mm	2°	4.25
2557	- 10°-300°	300 mm	2°	4.50
2558	- 10°-360°	300 mm	2°	5.50
2559	0°-400°	350 mm	2°	6.25
2560	0°-525°	400 mm	2°	7.35

Tubes with red liquid instead of mercury, with ranges up to 300° F or 150° C will be supplied if specified, at prices as listed above.

Machine Test Wells

1/2" S. P. T.

Made of cold rolled steel. Used in pipe lines with engraved stem test thermometers. Furnished with sealing plug and gasket.

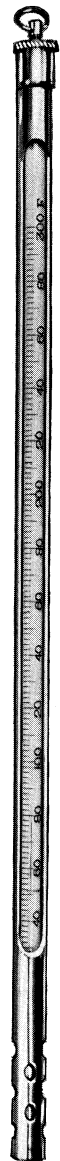

Closed
Bottom
Type

No.	Length Including Thread	Price
No. 725	—2 inches	\$2.00
No. 727	—4 inches	3.25
No. 729	—6 inches	4.50

Perforated
Bulb
Type

EXTRA QUALITY ENGRAVED STEM THERMOMETERS

Purpose to Be Used	Range	Div.	Length	No.	Price Each
Fuel Colorimeter	18° - 28° C	1/100°	600 mm	2125	\$16.50
	18° - 30° C	1/50°	450 mm	2126	12.00
Gas Colorimeter (Inlet) . . .	45° - 100° F	1/10°	18 in.	2130	8.50
Gas Colorimeter (Outlet) .	60° - 110° F	1/10°	18 in.	2131	8.50



No. 2110

Titer Test	0° - 20° C	1/10°	300 mm	2110	\$7.00
	20° - 40° C	1/10°	300 mm	2112	7.00
	40° - 60° C	1/10°	300 mm	2114	7.00
	0° - 65° C	1/10°	380 mm	2116	9.00
Moisture Test for Grain, Brown-Duvel Tester	0° - 220° C	1°	350 mm	2135	3.50
Benzol Distillation	70° - 90° C	1/5°	300 mm	2140	5.50
	100° - 120° C	1/5°	300 mm	2141	5.50
Laboratory Ovens	0° - 200° C	1°	600 mm	2145	3.75
	0° - 300° C	1°	600 mm	2146	4.00
Low Temperature	- 95° to 30° C	1°	300 mm	2150	8.00
	- 200° to 30° C	1°	350 mm	2151	12.00



No. 2163

Maximum Registering Thermometers	30° - 120° F	1°	6 in.	2160	\$3.00
	30° - 220° F	2°	6 in.	2161	3.00
	30° - 300° F	2°	9 in.	2162	3.75
	100° - 400° F	2°	9 in.	2163	4.50
	100° - 500° F	2°	9 in.	2164	5.25

A. S. T. M. THERMOMETERS

Test	Spec. A. S. T. M.	Range	Div.	Length	Immer- sion	No.	Price Per Doz.
High Distillation ...	D- 86-27	0°-400° C	1°	381 mm	Total	2050	\$72.00
	D- 86-27	30°-760° F	2°	15"	Total	2051	72.00
Low Distillation	D- 86-27	0°-300° C	1°	381 mm	Total	2052	60.00
	D- 86-27	30°-580° F	2°	15"	Total	2053	60.00
Cleveland Flash and Fire Test	D- 92-24	20°-760° F	5°	12"	1"	2055	54.00
	D- 92-24	6°-400° C	2°	305 mm	25 mm	2056	54.00
Loss on Heating ...	D- 6-27	155°-170° C	½°	6"	Total	2057	60.00
Melting Point of Wax and Petrolatum ..	D- 87-22						
	D-127-28T	80°-160° F	⅓°	14½"	3⅛"	2058	48.00
Melting Point of Bitu- minous Materials .	D- 36-26	30°-160° C	½°	381 mm	Total	2060	48.00
	D- 36-26	85°-320° F	1°	15"	Total	2061	48.00
" (ball and ring method)	D- 36-26						
	D- 61-24	2°- 80° C	⅓°	381 mm	Total	2062	48.00
	D- 61-24	30°-180° F	½°	15"	Total	2063	48.00
Cloud and Pour ...	D- 97-28	-36°-120° F	2°	8¾"	4¼"	2065	36.00
	D- 97-28	-38°- 50° C	2°	222 mm	108 mm	2066	36.00
Low Cloud and Pour	D- 97-28	-70°- 70° F	2°	9"	4¼"	2067	36.00
	D- 97-28	-60°- 20° C	1°	229 mm	108 mm	2068	36.00
Tag Closed and Pensky Martin Tester	D- 56-21	20°-230° F	1°	10¾"	2¼"	2070	36.00
	D- 93-22	7°-110° C	½°	273 mm	57 mm	2071	36.00
Pensky Martin Testers Only	D- 93-22	200°-700° F	5°	10¾"	2¼"	2072	60.00
	D- 93-22	90°-370° C	2°	273 mm	57 mm	2073	60.00
General Testing ...	D-182-25	0°-300° F	2°	12"	3"	2075	36.00
	D-182-25	-20°-150° C	1°	305 mm	76 mm	2076	36.00
	D-183-25	20°-580° F	2°	15"	3"	2077	45.00
	D-183-25	5°-300°-C	1°	381 mm	76 mm	2078	45.00
	D-184-25	20°-760° F	2°	16"	3"	2079	60.00
	D-184-25	5°-400° C	1°	406 mm	76 mm	2080	60.00

No. 2050



No. 2093

Saybolt Universal Viscosimeter Thermometers

Viscosity Test	A. S. T. M. Spec.	Range	Div.	Length	Immersion	No.	Price Per Doz.	
Test at {	25° C	D-88-26	19°- 27° C	1/10°	10"	Total	2090	\$48.00
	77° F	D-88-26	66°- 80° F	1/5°	10"	Total	2091	48.00
	40° C	D-88-26	34°- 42° C	1/10°	10"	Total	2092	48.00
	100° F	D-88-26	94°-108° F	1/5°	10"	Total	2093	48.00
	50° C	D-88-26	49°- 57° C	1/10°	10"	Total	2094	48.00
	122°-130° F	D-88-26	120°-134° F	1/5°	10"	Total	2095	48.00
	100° C	D-88-26	95°-103° C	1/10°	10"	Total	2096	48.00
	210° F	D-88-26	204°-218° F	1/5°	10"	Total	2097	48.00

No. 2065

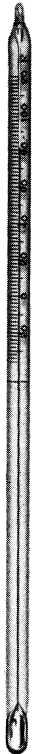

ARMORED AND POCKET CASE
THERMOMETERS FOR
INSPECTORS, ETC.

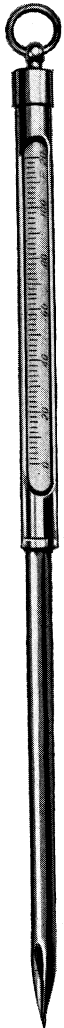

No. 513

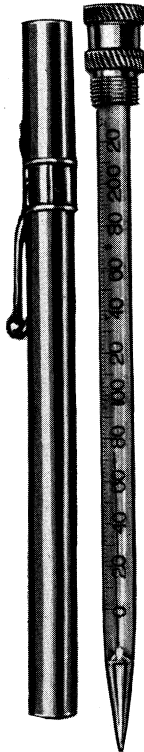

No. 503



No. 520

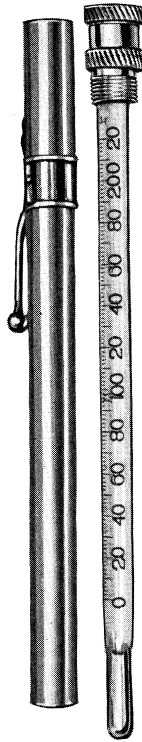

No. 501

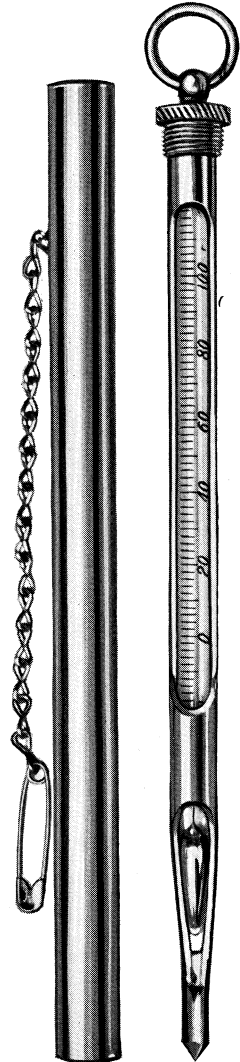

No. 510

	Fahrenheit Range	Div.	Length	No.	Price Each
Refrigeration	- 20°-120°	2°	6"	500	\$2.50
General Testing	0°-220°	2°	6"	501	2.50
Special Cold Storage, Pointed Bulb	- 20°-120°	2°	6"	502	2.50
Meat Testing, Pointed Bulb	0°-220°	2°	6"	503	2.50
Maximum Registering Pocket Thermometers, ranges up to 400° F or 200 C. Constriction feature		2°	6"	505	4.50
Armored Fruit Testing Thermometers					
Armor case has a pointed guard and is made of nickel-plated brass throughout	- 20°-120°	2°	8"	510	5.00
Meat Testing Thermometers (Long Stem)					
Nickel-plated brass armor case with sharp pointed stainless steel stem	- 20°-120°	1°	11½"	513	5.00
	30°-220°	2°	11½"	514	5.00
Armored Asphalt Testing Thermometers					
Nickel-plated steel armor case with pointed bulb chamber	200°-450°	2°	11"	520	5.00
	200°-600°	2°	11"	521	6.00

PAPER AND PORCELAIN SCALE THERMOMETERS

(Enclosed Type)

Paper scale thermometers for general factory use. Individually graduated scales with large easy reading numerals, red liquid or mercury.

No.	Range	Div.	Length	Price Per Doz.
No. 1500	- 10°-110° F	1°	6"	\$15.00
No. 1502	30°-220° F	2°	6"	15.00
No. 1504	- 10°-110° F	1°	12"	18.00
No. 1506	30°-220° F	1°	12"	18.00
No. 1508	- 20°- 50° C	1°	6"	15.00
No. 1510	0°-100° C	1°	6"	15.00
No. 1512	- 10°-110° C	1°	12"	18.00

Long stem paper or porcelain scale thermometers, scale body approximately 7/8" O. D. with diameter of stem approximately 1/2", depending on length. Prices quoted upon application.

Floating Dairy Thermometers

Best quality only, individually calibrated scales, large numerals, red liquid or mercury, properly constructed and weighted to float upright.

Range 0° to 220° F

No.	Length	Price Per Doz.
No. 1520	8" length	\$15.00
No. 1522	10" length	18.00
No. 1524	12" length	21.00

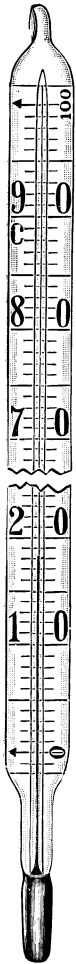

No. 1512

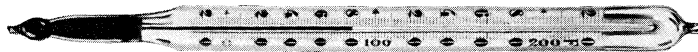

No. 1520



Porcelain Scale Long Stem Type

Acid Chamber Thermometers

(Angle Form)

Enclosed type, with scale individually calibrated with large easy reading numbers.

Range 30°-250° F

No.	Scale and Stem	Price Each
No. 1530	12" scale with 3" stem	\$2.50
No. 1532	12" scale with 6" stem	3.00

For greater length stems, prices quoted on applications.

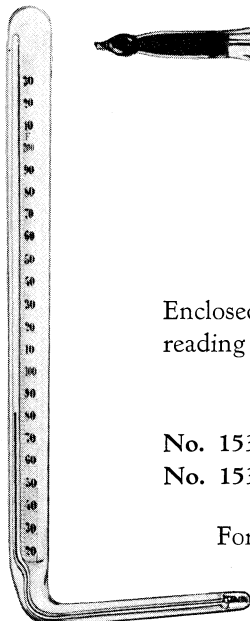

No. 1530

THE PHILADELPHIA THERMOMETER COMPANY

HYDROMETERS

Baume—Specific Gravity—Special Liquids

HEAVY LIQUIDS

Baume Scale 60° F			Specific Gravity 60° F				
No.	Range	Graduations	Price Each	No.	Range	Graduations	Price Each
1000	0° to 70°	1°	\$1.50	1100	1.000 to 2.000	.01	\$1.50
1001	0° to 50°	1°	1.50	1101	1.000 to 1.500	.005	1.50
1002	0° to 35°	1/2°	1.50	1102	1.500 to 2.000	.005	1.50
1003	0° to 25°	1/2°	1.50	1103	1.000 to 1.200	.002	1.50
1004	0° to 20°	1/2°	1.50	1104	1.200 to 1.400	.002	1.50
1005	0° to 10°	1/10°	2.00	1105	1.400 to 1.600	.002	1.50
1006	10° to 20°	1/10°	2.00	1106	1.600 to 1.800	.002	1.50
1007	20° to 30°	1/10°	2.00	1107	1.800 to 2.000	.002	1.50
1008	30° to 40°	1/10°	2.00	1108	1.000 to 1.100	.001	1.50
1009	40° to 50°	1/10°	2.00	1109	1.100 to 1.200	.001	1.50
1010	50° to 60°	1/10°	2.00	1110	1.200 to 1.300	.001	1.50
1011	60° to 70°	1/10°	2.00	1111	1.300 to 1.400	.001	1.50
1012	0° to 25°	1/5°	2.00	1112	1.400 to 1.500	.001	1.50
1113	25° to 50°	1/5°	2.00	1113	1.500 to 1.600	.001	1.50
1114	50° to 70°	1/5°	2.00	1114	1.600 to 1.700	.001	1.50
				1115	1.700 to 1.800	.001	1.50
				1116	1.800 to 1.900	.001	1.50
				1117	1.900 to 2.000	.001	1.50

LIGHT LIQUIDS

Baume Scale 60° F			Specific Gravity Scale 60° F				
No.	Range	Graduations	Price Each	No.	Range	Graduations	Price Each
1048	10° to 70°	1°	\$1.50	1150	.700 to 1.000	.01	\$1.50
1049	10° to 50°	1°	1.50	1151	.600 to .800	.002	1.50
1050	10° to 40°	1/2°	1.50	1152	.800 to 1.000	.002	1.50
1051	10° to 20°	1/10°	2.00	1153	.700 to .800	.001	1.50
1052	20° to 30°	1/10°	2.00	1154	.800 to .900	.001	1.50
1053	30° to 40°	1/10°	2.00	1155	.900 to 1.000	.001	1.50
1054	40° to 50°	1/10°	2.00				
1055	50° to 60°	1/10°	2.00				
1056	60° to 70°	1/10°	2.00				

SPECIAL LIQUIDS

Alcohol	Price Each	Lactometer (Milk)	Price Each
No. 1065— 0 to 100% alcohol by volume	\$1.25	No. 1075— 0° to 120°	\$1.50
No. 1066— 0 to 100% of Proof	1.25	No. 1076—15° to 45° Quevenne Scale with Thermometer	4.00
No. 1067—100% to 200% of Proof.....	1.25	Saccharometer (Balling)	
Calcium Chloride		No. 1080—0° to 14° 1/10° Div. 60° F	\$2.00
No. 1060—1.000 to 1.300 Spec. Gravity ..	\$1.50	No. 1081—0° to 24° 1/10° Div. 60° F 17" ..	3.00
No. 1061—Salometer 0 to 120% scale	1.50	Twaddle	
No. 1062—Salometer (Salt) 0° to 100% scale	\$1.50	No. 1085—#1 0° to 24° 1/2° Div.	\$1.50
No. 1061 F—Salometer 0 to 120% with freezing Point	2.25	No. 1086—#2 24° to 48° 1/2° Div.	1.50
No. 1060 F—1.000 to 1.300 Spec. Gravity with freezing Point	2.25	No. 1087—#3 48° to 72° 1/2° Div.	1.50
		No. 1088—#4 72° to 96° 1/2° Div.	1.50
		Barkometers	
		No. 1070—0° to 80° 1° Div.	\$1.50
		No. 1071—0° to 120° 1° Div.	1.75

For combination Thermo-Hydrometer (shown on page 45) use Catalog No. with suffix "C" and add \$2.00 to list.

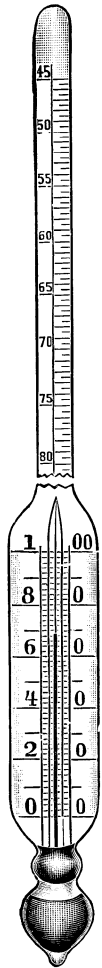

Combination
Thermo-
Hydrometer

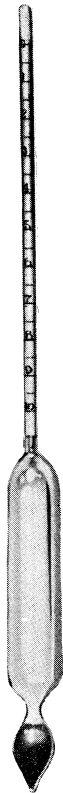

1005



1085



No. 1150

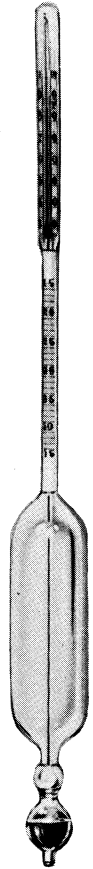

1076

HYDROMETERS

A. P. I. Scale for Determining Gravity of Oils

$$\text{A. P. I. Degrees} = \frac{141.5}{\text{Sp. Gr } 60^\circ} - 131.5$$

$$\frac{60^\circ \text{ F}}{60^\circ \text{ F}}$$

Length 13 Inches			Length 6 Inches		
No.	Range	Div.	No.	Range	Div.
1200	10°-100°	1°			
1201	10°-50°	½°	1250	10°-50°	1°
1202	50°-100°	½°	1251	50°-100°	1°
1203	10°-30°	¼°	1252	10°-30°	½°
1204	20°-40°	¼°	1253	20°-40°	½°
1205	30°-50°	¼°	1254	30°-50°	½°
1206	40°-60°	¼°	1255	40°-60°	½°
1207	50°-70°	¼°	1256	50°-70°	½°
1208	60°-80°	¼°	1257	60°-80°	½°
1209	70°-90°	¼°	1258	70°-90°	½°
1210	80°-100°	¼°	1259	80°-100°	½°
1211	10°-21°	⅒°	1260	10°-21°	⅓°
1212	19°-31°	⅒°	1261	19°-31°	⅓°
1213	29°-41°	⅒°	1262	29°-41°	⅓°
1214	39°-51°	⅒°	1263	39°-51°	⅓°
1215	49°-61°	⅒°	1264	49°-61°	⅓°
1216	59°-71°	⅒°	1265	59°-71°	⅓°
1217	69°-81°	⅒°	1266	69°-81°	⅓°
1218	79°-91°	⅒°	1267	79°-91°	⅓°

For combination Thermo-Hydrometer (shown above) use Catalogue number with suffix "C" and add \$2.00 to list.

RELATIVE HUMIDITY, PERCENT—FAHRENHEIT TEMPERATURES
BAROMETRIC PRESSURE 30.0 INCHES

DRY BULB Thermometer Readings	DIFFERENCE IN DEGREES FAHRENHEIT BETWEEN WET AND DRY BULB THERMOMETERS.																													
	1	2	3	4	5	6	7	8	9	10	11	12	13	14	15	16	17	18	19	20	21	22	23	24	25	26	27	28	29	30
200	98	96	94	92	90	88	86	84	82	80	79	77	75	74	72	70	69	67	66	64	63	61	60	58	57	55	54	53	52	51
190	98	96	94	92	90	88	85	84	82	80	78	76	75	73	71	69	68	66	65	63	62	60	58	57	56	54	53	51	50	49
188	98	96	94	92	90	87	85	84	82	80	78	76	74	73	71	69	68	66	64	63	62	59	58	57	55	54	52	51	50	49
186	98	96	94	92	90	87	85	83	82	80	78	76	74	72	71	69	67	66	64	62	61	59	58	56	55	53	52	51	49	48
184	98	96	94	92	89	87	85	83	82	79	77	76	74	72	70	69	67	65	64	62	61	59	57	56	55	53	52	50	49	48
182	98	96	94	91	89	87	85	83	81	79	77	75	74	72	70	68	67	65	63	62	60	59	57	56	54	53	51	50	49	48
180	98	96	94	91	89	87	85	83	81	79	77	75	73	72	70	68	67	65	63	62	60	58	57	55	54	52	51	50	48	47
178	98	96	94	91	89	87	85	83	81	79	77	75	73	72	70	68	66	64	63	61	60	58	56	55	54	52	51	49	48	47
176	98	96	94	91	89	87	85	83	81	79	77	75	73	71	70	68	66	64	63	61	60	58	56	55	53	52	50	49	48	46
174	98	95	93	91	89	87	84	83	81	78	76	75	73	71	69	67	66	64	62	61	59	57	56	54	53	51	50	49	47	46
172	98	95	93	91	89	86	84	82	81	78	76	74	73	71	69	67	66	64	62	60	59	57	55	54	53	51	50	48	47	46
170	98	95	93	91	89	86	84	82	80	78	76	74	72	70	69	67	65	63	62	60	59	57	55	53	52	51	49	48	47	45
168	98	95	93	91	88	86	84	82	80	78	76	74	72	70	68	67	65	63	61	60	58	56	55	53	52	50	49	47	46	45
166	98	95	93	91	88	86	84	82	80	78	76	74	72	70	68	66	65	63	61	59	58	56	54	53	51	50	48	47	46	44
164	98	95	93	91	88	86	84	82	80	78	75	73	72	70	68	66	64	62	61	59	58	56	54	52	51	49	48	47	45	44
162	98	95	93	90	88	86	84	82	80	77	75	73	71	69	68	66	64	62	60	59	57	55	54	52	51	49	47	46	45	44
160	98	95	93	90	88	86	83	81	79	77	75	73	71	69	67	65	64	62	60	58	57	55	53	52	50	49	47	46	44	43
158	98	95	93	90	88	86	83	81	79	77	75	73	71	69	67	65	63	61	60	58	56	55	53	51	50	48	47	45	44	43
156	98	95	93	90	88	85	83	81	79	77	74	72	71	69	67	65	63	61	59	58	56	54	53	51	49	48	46	45	43	42
154	98	95	93	90	88	85	83	81	79	77	74	72	70	68	66	65	63	61	59	57	56	54	52	50	49	47	46	44	43	42
152	98	95	93	90	88	85	83	81	79	76	74	72	70	68	66	64	62	60	59	57	55	53	52	50	48	47	46	44	42	41
150	98	95	92	90	87	85	82	80	78	76	74	72	70	68	66	64	62	60	58	57	55	53	51	49	48	46	45	43	42	41
148	97	95	92	90	87	85	82	80	78	76	73	71	69	67	65	63	61	60	58	56	54	53	51	49	48	46	45	43	42	40
146	97	95	92	90	87	85	82	80	78	75	73	71	69	67	65	63	61	59	57	56	54	52	50	49	47	45	44	43	41	40
144	97	95	92	89	87	84	82	80	78	75	73	71	69	67	65	63	61	59	57	55	53	52	50	48	47	45	44	42	41	39
142	97	94	92	89	87	84	82	80	77	75	73	70	68	66	64	62	60	58	57	55	53	51	49	48	46	44	43	42	40	39
140	97	94	92	89	87	84	82	79	77	75	73	70	68	66	64	62	60	58	56	54	53	51	49	47	46	44	43	41	40	38
138	97	94	92	89	87	84	82	79	77	75	72	70	68	66	64	62	60	58	56	54	52	50	49	47	45	44	42	40	39	37
136	97	94	92	89	86	84	81	79	77	74	72	70	68	65	63	61	59	57	55	54	52	50	48	46	45	43	41	40	38	37
134	97	94	92	89	86	84	81	79	76	74	72	69	67	65	63	61	59	57	55	53	51	49	48	46	44	43	41	39	38	36
132	97	94	92	89	86	84	81	79	76	74	71	69	67	65	63	61	58	56	55	53	51	49	47	45	44	42	40	39	37	36
130	97	94	91	89	86	83	81	78	76	73	71	69	67	64	62	60	58	56	54	52	50	48	47	45	43	41	40	38	37	35
128	97	94	91	89	86	83	81	78	76	73	71	68	66	64	62	60	58	56	54	52	50	48	46	44	42	41	39	37	36	34
126	97	94	91	88	86	83	80	78	75	73	70	68	66	64	61	59	57	55	53	51	49	47	45	44	42	40	38	37	35	33
124	97	94	91	88	85	83	80	78	75	73	70	68	65	63	61	59	57	54	52	50	48	47	45	43	41	39	38	36	34	33
122	97	94	91	88	85	83	80	77	75	72	70	67	65	63	60	58	56	54	52	50	48	46	44	42	40	39	37	35	34	32
120	97	94	91	88	85	82	80	77	74	72	69	67	65	62	60	58	55	53	51	49	47	45	43	41	40	38	36	34	33	31
118	97	94	91	88	85	82	79	77	74	72	69	67	64	62	59	57	55	53	51	49	47	45	43	41	39	37	35	34	32	30
116	97	94	91	88	85	82	79	76	74	71	69	66	64	61	59	57	54	52	50	48	46	44	42	40	38	36	34	33	31	29
114	97	94	91	88	85	82	79	76	74	71	68	66	63	61	58	56	54	52	49	47	45	43	41	39	37	35	34	32	30	28
112	97	94	90	87	84	81	79	76	73	70	68	65	63	60	58	55	53	51	49	47	44	42	40	38	36	35	33	31	29	27
110	97	93	90	87	84	81	78	75	73	70	67	65	62	60	57	55	52	50	48	46	44	42	40	38	36	34	32	30	28	26
108	97	93	90	87	84	81	78	75	72	70	67	64	62	59	57	54	52	49	47	45	43	41	39	37	35	33	31	29	27	25
106	97	93	90	87	84	81	78	75	72	69	66	64	61	58	56	53	51	49	46	44	42	40	38	36	34	32	30	28	26	24
104	97	93	90	87	83	80	77	74	71	69	66	63	60	58	55	53	50	48	46	43	41	39	37	35	33	31	29	27	25	23
102	96	93	90	86	83	80	77	74	71	68	65	62	60	57	55	52	49	47	45	42	40	38	36	34	32	30	28	26	24	22
100	96	93	89	86	83	80	77	73	70	68	65	62	59	56	54	51	49	46	44	41	39	37	35	33	30	28	26	24	22	21

Formula for transposing temperature values:

$$F^{\circ} = \frac{C^{\circ} \times 9}{5} + 32$$

$$C^{\circ} = \frac{F^{\circ} - 32 \times 5}{9}$$

PRINTED IN U. S. A.
CLARK PRINTING HOUSE
Philadelphia