

W. B. No. 148.

U. S. DEPARTMENT OF AGRICULTURE,
WEATHER BUREAU.

AN IMPROVED SUNSHINE RECORDER.

PREPARED UNDER THE DIRECTION OF
WILLIS L. MOORE,
CHIEF OF WEATHER BUREAU.

BY

D. T. MARING,
INSTRUMENT DIVISION.

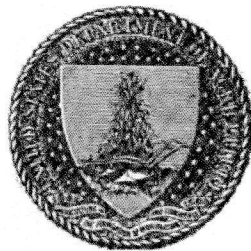

WASHINGTON:
WEATHER BUREAU.
1898.

277
BUREAU OF
CALIFORNIA

AN IMPROVED SUNSHINE RECORDER.¹

The radiant energy of the sun produces several different effects at the surface of the earth, viz, *light, heat, and chemical changes*. To obtain records of these effects from hour to hour and day to day, as is done of other atmospheric phenomena, and thus obtain the total work done by sunshine, has been a most difficult problem for meteorologists, and one that has not yet been successfully solved. Automatic instruments have been devised for securing approximate records of the intensity and duration of each of these effects separately, but nothing has yet been perfected that will accurately indicate simultaneously the varying intensity of two effects such as the heat and light received from the sun.

Probably the first automatic sunshine recorder ever invented was that described in 1838 by Mr. Thomas B. Jordan, a mathematical and philosophical instrument maker, and Secretary to the Royal Cornwall Polytechnic Society, Falmouth, England.² This was developed in connection with Mr. Jordan's efforts to produce a uniform and automatic system of self-registration for the various meteorological instruments then in use in that country, especially the mercurial barometer. For a record chart he used a paper covered with chloride of silver, which had about that time (1838) been discovered to be sensitive to the action of light, and to take different tints in proportion to the intensity of the light to which it was exposed, provided the times of duration of the exposures were equal. This paper was mounted on an inclosed vertical cylinder moved by clockwork and was placed directly behind the top of the mercurial column of the barometer, so that the surface of the paper would be exposed more or less to the action of diffused sunlight through the glass tube, depending upon the variations in barometric pressure. The vertical time lines were printed on the sheet and, by means of opaque lines for inches, etc., graduated on the glass tube, the barometer scale, the fluctuations in barometric pressure, and the time and comparative intensity of sunlight were all automatically and indelibly recorded on the sensitized paper by the action of the light itself.

This apparatus certainly embodied some very ingenious ideas, and appears to have constituted not only one of the earliest forms of self-recording barometers, but contained also the first automatic register of sunshine. As Mr. Jordan

¹ Reprinted from the Monthly Weather Review for November, 1897.

² See the Sixth Annual Report of the Royal Cornwall Polytechnic Society, 1838, p. 184.

makes no mention of the use of artificial light, it is presumed records from this barometer-sunshine apparatus were secured only during the hours of daylight, and his sample records, as engraved and reproduced in the report referred to,¹ are blank at nighttime.

Mr. Jordan's next attempt was to produce an independent instrument for sunshine alone, which he proposed to call "The Heliograph," a name more correctly applied subsequently to a very different form of apparatus. With this "Heliograph" he expected to obtain "an accurate account of the intensity of the light for every minute of the day, and to permanently register its indications." He describes his apparatus as follows:²

It consists of a light cylinder of metal, with a similar cylinder revolving about it, once in twenty-four hours, on a screwed axis. The inner and fixed cylinder is covered with a sheet of the prepared paper, and the outer or revolving one has a small hole in it, through which the light shines on the paper.

The axis of the cylinder and the position of the hole is so adjusted that the hole shall at all times be opposite to the place of the sun, and may, therefore, be considered as its picture traveling over the paper; it is found that the muriate of silver, with which the paper is covered, takes different tints, in proportion to the intensity of the light to which it is exposed, provided that the times of exposure be equal; and it will be seen that the mechanical arrangements just described will cause the hole in the outer cylinder to pass over the paper in a spiral line, every point of which will be illuminated for an equal time, and consequently its intensity at any given hour will be a correct representation of the intensity of light at that time, and the peculiarity of tint will show whether the sun were shining or obscured, and the degree of obscuration. The object of making the aperture to revolve in a spiral line is, that it may register the indications of a number of days on one sheet of paper without personal attention; each coil of the spiral will, of course, represent the light of one day, and the cylinder being driven by a clock (which may, at the same time, be employed for all the other instruments) the sheet when taken off will have eight parallel lines across it, correctly representing the light of the different days on which they were drawn, and will, together with the sheets from the other instruments, form a more perfect register of the state of the atmosphere for that time than could possibly be produced by the present mode of observation (1838).

An improved design of the above was brought out by Mr. Jordan in 1840,³ which he describes as follows, under the title of "Description of a new arrangement of the Heliograph, for registering the intensity of Solar Light":

The instrument for this purpose, described in pages 185 and 186 of the last Annual Report of the Society, is obviously defective, in as much as it calls on the observer's judgment to decide the intensity of the light, by a comparison of the different tints given by it to the prepared paper, and does not therefore admit of any definite mode of expressing the results of each instrument, so that those at distant stations may be compared with each other; and in consequence of the changes which the different tints undergo in fixing (and subsequently

¹ Ibid, Plate VII.

² Ibid, pp. 185-186.

³ Seventh Annual Report, Royal Cornwall Polytechnic Society, 1839, p. 115.

to that proc
any useful
distant time
difficulties,
that the lig
by it in a w
reading, and
lated with
away with
as they may

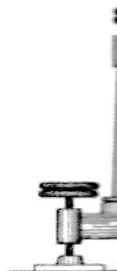

FIG. A.—T.

The accoun
It consists
interior one
support of t
volve about
It has a tria
figure, and
spring clos
composed o
paper, and
other part b
without any
treme divis
other, as on
one hundre
one over it
these divis
the same p

Now, as th
the most im
during its g
produce a si
number of
comparative
may be regi
register the
ble to comp
be requisite
precisely un

¹ Ibid, Pl

to that process), however carefully conducted, it is not possible to make any useful comparison of results obtained by the same instrument at distant times. The object of the present arrangement is to avoid these difficulties, by reducing the indications of the instrument to a scale, so that the light of each day, or each hour, may be distinctly registered by it in a way that will not admit of any difference of opinion as to the reading, and which may be at once expressed by a *number* and tabulated with other meteorological observations. This, of course, does away with all occasion for fixing the sheets with the results on them, as they may be destroyed as soon as these results are known.

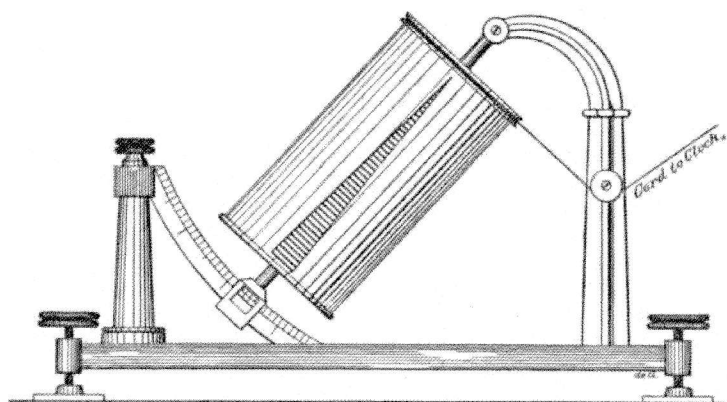

FIG. A.—T. B. Jordan's Sunshine Recorder (Heliograph), pattern of 1840.

The accompanying sketch (Fig. A)¹ is an elevation of the instrument. It consists of two copper cylinders supported in a metal frame. The interior one is fixed to the axis, and does not revolve, being merely the support of the prepared paper. The exterior cylinder is made to revolve about this one once in twenty-four hours by a clock movement. It has a triangular aperture cut down its whole length, as shown in the figure, and it carries the scale of the instrument, which is made to spring closely against the prepared paper. This scale, or screen, is composed of a sheet of metal foil between two sheets of varnished paper, and is divided into one hundred parts longitudinally, every other part being cut out, so as to admit the light to the prepared paper without any transparent medium intervening. The length of the extreme divisions measuring round the cylinder are proportioned to each other, as one to one hundred, consequently the lower division will be one hundred times longer passing over its own length than the upper one over its own length, and the lines of the prepared paper under these divisions will, of course, be exposed to the light for times bearing the same proportion to each other.

Now, as the sensitiveness of the paper can readily be adjusted so that the most intense light will only just tint it through the upper division during *its passage* under the opening, and the most feeble light will produce a similar tint through the lower division during *its passage*, the number of lines marked on the paper at any given time will furnish a comparative measure of the intensity of solar light at that time, and may be registered as so many degrees of the heliograph just as we now register the degrees of the thermometer. If it were considered desirable to compare the results of different instruments, of course it would be requisite that the scales should be exactly similar and the paper of precisely uniform quality.

¹ Ibid, Plate III, Fig. 3.

Other modifications of this instrument were also made by Mr. T. B. Jordan, but, owing to the undeveloped state of photography sixty years ago, the records he obtained were not considered very satisfactory, and the instruments were found to be too expensive and unreliable for general use. At that early date there were, of course, no great national meteorological services in existence to take up and develop apparatus of this kind. It appears, therefore, that Mr. T. B. Jordan was the pioneer inventor in this field, and that his "photographic" sunshine recorders of 1838 and 1840 were the first of the kind used anywhere in the world prior to 1854.

Among the various forms of the so-called "sunshine recorders" that have been devised for measuring the time and duration of bright sunshine, one of the most important is that known as the "Burning" recorder, invented by Messrs. Campbell and Stokes of England, in 1854, and the improved form of the same designed in 1890 by Messrs. Whipple and Casella. These instruments have been used more or less extensively by foreign meteorological services since 1854, and operate on the same principle, that is, by concentrating the sun's rays through a glass sphere, acting as a powerful lens, upon a suitably ruled cardboard form, curved and held in focus at all hours of the day. But the degree of burning or charring of the line across this form or chart, for each day's record, gives only a very crude approximation to the thermal intensity of the sun's rays. The original "Burning" recorder, first designed by Mr. Campbell in 1854, used a glass ball filled with water as the lens; this was set within a round, shallow, mahogany bowl, having a radius such that the surface of the wood was constantly in the focus of the lens. This apparatus being placed where it could receive the sun's rays at all hours of the day, the wood was burned or charred into a series of irregular grooves around the inner sides, and the bowls were of such size and shape that each contained a six-months' record. Thus was obtained a very crude record of the duration and intensity of the heat effect of sunshine for semiannual periods, but this must have been so imperfect as to constitute but the roughest seasonal approximation. The water globe was soon found impractical and was replaced by a suitable solid glass sphere, but the wooden bowls were apparently continued in use for several years before being generally replaced by the more convenient cardboard forms invented by Whipple and Casella. Mr. James B. Jordan (not Thomas B.), in reporting to the Royal Meteorological Society on this subject in 1885, states also that at least one of these instruments using the wooden bowl was kept in operation at Whitehall, England, for several years, and that these curious and interesting original records (i. e., the bowls) were then in the possession of the British Meteorological Office at Kew.

The photographic sunshine recorder now used by the British meteorological service is that designed by Mr. James B. Jordan,

in 1885. The
shine (actin
same princip
Bureau phot
tional modifi
Fig. 1. In t
Prof. C. F.
changed only
is resorted t
effects of the
of the sun.

Fig. 1.—Photo

In 1891, t
thermomete
means of wh
automatical
standard re
with other
extensively
in the Unite
recorder sho
W. B. No. 10
Recorders."
kinds of su
from this in
comparable
the photogr
various diff

in 1885. This makes a record of the time of duration of sunshine (actinic effects) on sensitized, blue-print paper. The same principle has been used for several years in the Weather Bureau photographic sunshine recorder, which is a constructional modification of Jordan's invention, and is shown in Fig. 1. In the Weather Bureau instrument, as designed by Prof. C. F. Marvin, in 1888, the sensitized sheets need be changed only once or twice a month, and a simple expedient is resorted to, in ruling the record sheets, to eliminate the effects of the progressive variations in the meridional altitude of the sun.

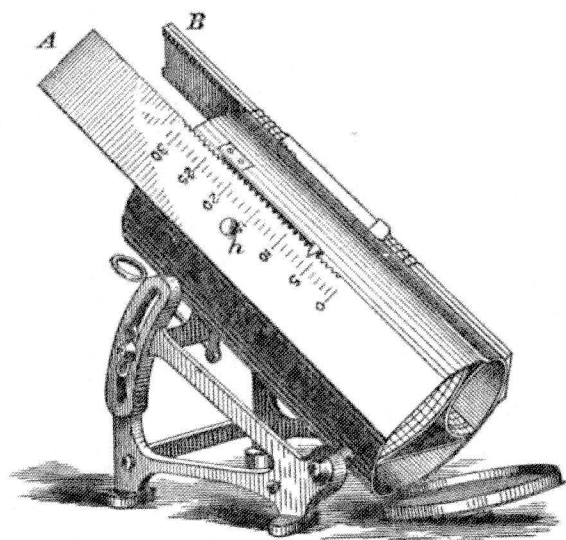

FIG. 1.—Photographic sunshine recorder.—Weather Bureau pattern of 1888.

In 1891, the present writer suggested a form of differential thermometer as a sunshine recorder, illustrated in Fig. 2, by means of which the presence of effective sunshine could be automatically and electrically recorded at a distance on the standard registers of the Weather Bureau, simultaneously with other data. This "thermometric recorder" has been extensively introduced at the regular stations of the Bureau in the United States, and in connection with the photographic recorder shown in Fig. 1, is fully described in the pamphlet, W. B. No. 109, entitled "Care and Management of Sunshine Recorders." It is probable, however, that as in all other kinds of sunshine recorders, so now, the records obtained from this instrument at the various stations are not strictly comparable with each other, nor with those obtained from the photographic sunshine recorders, owing in part to the various different adjustments of the mercurial column that

are unavoidable in an instrument operating upon this differential thermometer principle.

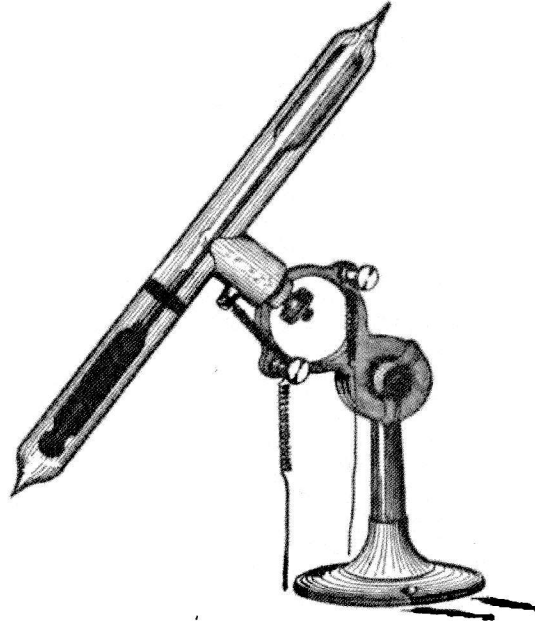

FIG. 2.—Thermometric sunshine recorder (pattern of 1895) mounted.

From careful comparative tests made in England, Mr. James B. Jordan decided that although his improved photographic instrument (using blue-print paper) registered, on an average, about 11 per cent more sunshine than the "Burning" recorder, yet there is no real antagonism in the records (each being valuable) for, while the former registers the delicate actinic effect, the latter gives only the grosser heat effect for a certain greater degree of intensity ordinarily known as "bright sunshine."

To record and tabulate simply the duration, in hours and minutes, of bright sunshine, as obtained by the above-mentioned sunshine recorders, and, as is now generally done by the various meteorological services throughout the world, does not give all the information desired relative to the sun's rays, nor all that is really required for a satisfactory study of this important element in meteorology. What seems to be really needed is a simple form of apparatus which will automatically and simultaneously record each of the various effects of radiant energy in such a way that the real varying intensities of all parts of the solar spectrum will be obtained in a satisfactory and comparable manner.

Our present knowledge of solar radiation (excepting the important work done by Crova at Montpellier with his

self-rec
records
nomete
bulb th
at such
compa
preted
ing per
not be
under
sunshi
at num

The
on the
averag
the zen
This o
any au
fect it
of sun
the no
logical
ature
santly
circula
known
of the
tive to
total s

The
surmo
thus f
tinuou
beam
and el
observ

But
efforts
at hea
science
physic
appar
of giv
posure
able.

The
severa
had be
gives
the pr
ments

self-registering solar actinometer) has been obtained from records secured by eye observations of several forms of actinometers, heliometers, bolometers, and bright and black bulb thermometers in vacua; but the observations were made at such a very few points on the earth's surface, and for such comparatively short periods of time and have been interpreted by the help of such imperfect theories that the resulting percentages of solar radiation reaching the earth should not be accepted as final and absolute for all localities and under all conditions. It is believed that complete records of sunshine should be continuously and automatically secured at numerous points on the earth's surface.

The atmosphere has a large and constantly varying effect on the amount of heat and light received by the earth; the average intensity of the radiant energy when the sun is in the zenith is over 35 times greater than at sunrise and sunset. This constitutes one of the greatest difficulties to be met in any automatic instrument, for if the apparatus is to be *perfect* it should be sensitive enough to record the feeblest rays of sunrise and sunset, as well as the most powerful rays of the noonday sun. It is well known, from general meteorological observations, that the humidity as well as the temperature of the air is constantly changing; clouds are incessantly being formed and dissipated at various elevations; the circulation of the upper air currents is only imperfectly known, and, as all these elements affect the absorbing power of the air, we need an apparatus that shall be highly sensitive to sudden changes in order to give correct percentages of total sunshine.

These difficulties have, heretofore, been considered so insurmountable that no attempts appear to have been made thus far to design an instrument to automatically and continuously record the actual intensity of the whole of a sunbeam at the earth's surface, except indeed the very expensive and elaborate apparatus used by Langley at his astrophysical observatory in Washington, and that of Crova at Montpellier.

But all these difficulties should not discourage further efforts by those who have the best interests of meteorology at heart, and who desire to see it advanced to a more perfect science. It is believed that a suitable instrument is not a physical nor a mechanical impossibility, and, if such an apparatus can be secured, the matter of standardizing it, and of giving a number of them uniform and comparable exposures throughout the country, should not be insurmountable.

The writer has been experimenting in this connection for several years past, and, after numerous plans and suggestions had been tried, an instrument was finally devised which now gives promise of fruitful results. This is a combination of the principles contained in the two Weather Bureau instruments, the photographic and thermometric sunshine recorders,

respectively, whereby the height of the column of mercury in the latter instrument is automatically recorded on a strip of photographic (blue print) paper.

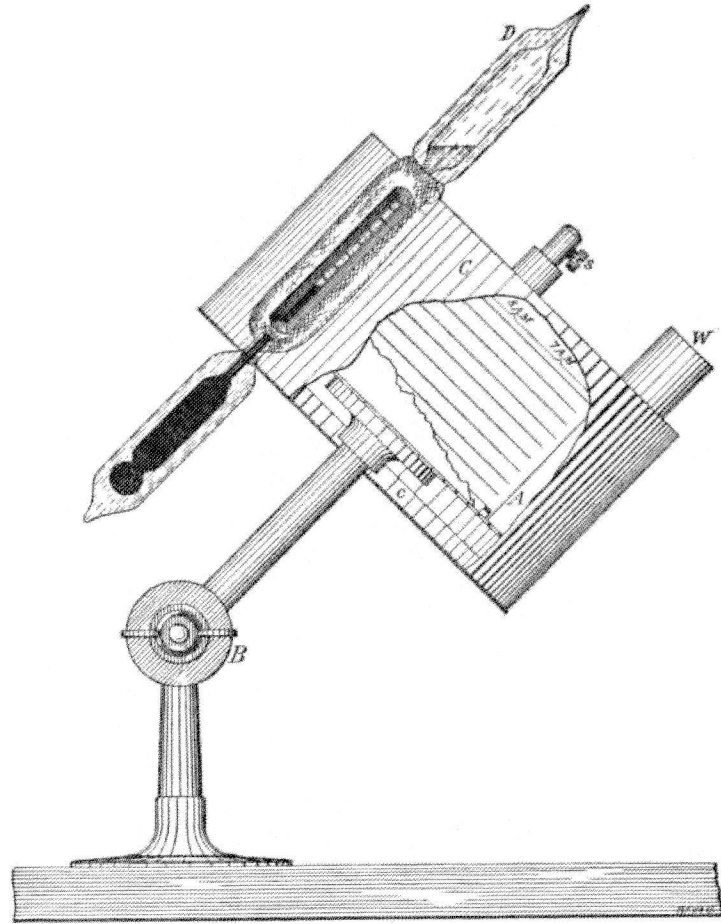

FIG. 3.—New photo-thermo recorder. (Maring's original working model of 1897).

The original working model is shown in Fig. 3, part of the outer cylinder being cut away to illustrate the method of operation. *A* is a circular brass case inclosing a strong 8-day clock movement and rigidly mounted on the adjustable metal support *B*. The clock turns the outer cylinder *C* (which is also of brass) once in twenty-four hours, and keeps the differential, bright and black-bulb thermometer of glass *D* constantly exposed directly toward the sun. The cap, *c*, closes the lower end of the cylinder *C* perfectly tight, and is held in place by friction. The cylinder itself is secured to the clock-

pinion by sensitized central slot cut through the glass, and covered by the intensity of the paper is held in

This is the sun's the year, earth. C the case projecting p and indic It will be the instr on each the slot lines for photogra reproduc thermom reau ther bulb is in rigidly to cylinder counterb rate for t

By a somewhat recorder writer ha years ago

This p much im out addi produce The inex reliable t an appar if the cl by suita ential th as at pre ord of in corder op is secure the recor the pres sensitive

pinion by the set screw, *s*, and is removed entirely when a new sensitized sheet is to be put in place. Directly behind the central stem of the differential thermometer a narrow slot is cut through the cylinder *C*, so that it will be completely covered by the mercurial column as it rises with the increasing intensity of sunshine. The strip of sensitized photographic paper is wrapped around the circumference of the part *A* and is held in place by suitable clips.

This apparatus is placed in a position where it will receive the sun's rays at all hours of the day and at all seasons of the year, the cylinder *C* being parallel with the axis of the earth. Ordinary blue-print paper is used, and is attached to the case *A* with the upper edge of the sheet under a fixed projecting piece of thin brass having the hours perforated therein and indicated by notches or holes at accurate distances apart. It will be seen that, as the cylinder *C* revolves with the sun, the instrument will automatically record its own time marks on each sheet. Furthermore, by stretching fine wires across the slot behind the mercurial column, the horizontal record lines for the scale of varying intensities of sunshine will be photographed in white, as indicated by the sample records reproduced herewith. The differential bright and black-bulb thermometer *D* is made similar to the present Weather Bureau thermometric sunshine recorder (Fig. 2), except that each bulb is in an independent vacuum. The glass tube is attached rigidly to the cylinder *C* and cemented in place so that the cylinder is water-tight. The weight of this glass part is counterbalanced by the weight *W*, so as to insure a regular rate for the clock.

By a coincidence, this apparatus must, in appearance, somewhat resemble the above-mentioned original sunshine recorder of 1838, although when designed in March, 1897, the writer had no knowledge of Mr. T. B. Jordan's device of sixty years ago.

This photo-thermo recorder is, of course, capable of being much improved as regards mechanical construction. Without adding much to its size or cost it can readily be made to produce an entire week's record, which is very desirable. The inexpensive American clocks are strong and sufficiently reliable timekeepers for the out-of-door conditions to which an apparatus of this kind must necessarily be exposed. Still, if the clock is unsatisfactory the cylinder could be revolved by suitable mechanisms operated by electricity. The differential thermometer could also be made electrically recording, as at present, without interfering with the photographic record of intensity. One of the advantages of a photographic recorder operating on this principle is that the sensitized paper is securely inclosed and protected in a water-tight case, and the records can not be affected by rain and dampness, as in the present forms of these recorders. A more delicate and sensitive paper can therefore be safely used. Another advan-

tage is that it uses the plain, blue-print paper, which can now be procured almost everywhere of dealers in photographic supplies, which paper is generally of far greater excellence than any that can be made in small quantities by hand.

Some sample records, by this process, of the time, duration, and intensity of sunshine (and cloudiness during daylight), are reproduced, as accurately as practicable in the accompanying illustrations, Figs. 4, 5, and 6. The corresponding descriptions in the appendix to this article give full details as to the conditions under which these records were made.

A sufficient number of comparative simultaneous observations with other apparatus has not yet been obtained to determine exactly the meaning of the varying intensities as given by this. In this model instrument the wires (*lines*, as shown on records) were arbitrarily placed equidistant apart, so as to approximately indicate differences of 5° F. in the readings of the standard bright and black-bulb thermometers in vacua. It was found afterwards, however, that the intensity of the heat and light effects of sunshine by this apparatus is by a *varying* scale of decreasing differences (between these thermometer readings) which scale has been estimated and is indicated approximately on the sample record for November 23, 1897 (Fig. 5).

These sample records are strictly comparable, as regards the angular adjustment of the mercurial column of the differential thermometer *D*, which was the same for all, and was not changed or altered while these records were being made.

As temperature has a slight effect on the mercury contained in differential thermometers of this form, and therefore on records produced thereby, a device could, perhaps, be made to automatically change the inclination of the instrument, and thus compensate for all temperature effects and cover the range from the maximum of summer to the minimum of winter. Something of this kind, that could be attached to the present form of electrical sunshine recorder, would be a valuable improvement.

Information relative to the intensity of solar radiation has been urgently needed for many years in the study of sanitary climatology and in investigations as to growth of crops and agricultural interests generally, and it is hoped this article may lead either to the perfection of present forms of sunshine recorders, or to the invention of something new that will furnish this important factor in our meteorological problems.

APPENDIX.

Figure 4.—Photo-thermo sunshine record, September 30, 1897. Washington, D. C.

Sunrise at 5:56 a. m.; sunset 5:44 p. m.; total possible duration of sunshine, 11 h. 48 min. Light smoke in morn-

ing to
light r
shine o
and cl
instru
1:45 an
mum t
at 3 p.
p. m.,
a. m.,
black b
Note
record
sunshi
record.

Figure
Wash
a. m.

Poss
leaving
and pe
and sc
peratur
at mid
curred
maxim
differen
0° to 4

Note
the occ

Figure
Wash
a. m.

Poss
leaving
and cl
Winds
at 3 p.
black-
bulb t
The
the dif
photog
The
matica

ing to 7:30, and in afternoon after 4:30, interfered with twilight record, making indicated record of duration of sunshine only 10 h. 50 min. Weather unusually clear, warm, and cloudless; only two small clouds came between the instrument and the sun of about 5 minutes duration each, at 1:45 and 1:55 p. m. Winds very light and easterly. Minimum temperature, 45° , at 6 a. m.; maximum temperature, 83° , at 3 p. m. Maximum intensity of sunshine occurred at 1:30 p. m., although the intensity was nearly equal to this at 11:25 a. m., and at 12:45 p. m. Difference between bright and black bulb thermometers, same exposure, 35° .

Note the large variations in thermometric intensity on this record with apparently the same uniform conditions of sunshine, viz, cloudless sky, as shown by the photographic record.

*Figure 5.—Photo-thermo sunshine record, November 23, 1897.
Washington, D. C. (Record for a part of the day, i. e., 7:50 a. m. to 2:40 p. m.)*

Possible sunshine, 6 h. 50 min.; cloudiness, 2 h. 30 min., leaving 4 h. 30 min. as duration of sunshine. Weather cold and partly cloudy, with brisk to high northwesterly winds and scattering flakes of snow at 2:15 p. m. Maximum temperature, 46° , at midnight 22d; minimum temperature, 32° , at midnight 23d. The maximum intensity of sunshine occurred at 11:25 a. m.; black-bulb thermometer, in vacuum, maximum, 124° ; bright-bulb thermometer, in vacuum, 99° ; difference, 25° . Scale of varying intensities approximated, 0° to 43° .

Note the prompt decrease in thermometric intensity with the occurrence of cloudiness.

*Figure 6.—Photo-thermo sunshine record, December 6, 1897.
Washington, D. C. (Record for a part of a day, i. e., 8:40 a. m. to 3:20 p. m.)*

Possible sunshine, 6 h. 40 min.; cloudiness, 1 h. 20 min., leaving 5 h. 20 min. duration of sunshine. Weather cold and clear up to 1:40 p. m., when clouds began to form. Winds light to brisk northerly. Maximum temperature, 45° , at 3 p. m. Maximum intensity of sunshine at 12:50 p. m.; black-bulb thermometer, maximum, in vacuum, 110° ; bright-bulb thermometer, maximum, in vacuum, 82° ; difference, 28° .

The sudden decrease in intensity at 1:45 p. m., affecting the differential thermometer but not sufficient to affect the photographic record of sunshine, is very remarkable.

The time (hour) marks on this record were produced automatically, as already described.

ADDENDUM.

Since the preparation of the foregoing an opportunity has been presented of reading a summary of the proceedings of a recent meeting of the Royal Meteorological Society,¹ at which an interesting discussion was held relative to the comparative merits of the Campbell-Stokes Burning Recorder and the Jordan Photographic Recorder.

Mr. R. H. Curtis submitted a paper setting forth the history and description of these two forms of recorder, and gave the following conditions as requisite for a satisfactory comparison :

- (1) Care must be taken that the instruments are in proper adjustment, and are fair examples of the types.
- (2) They should occupy positions similar in every respect, and such as to give an absolutely clear horizon.
- (3) The comparison should extend over a period sufficiently long to test them under varying seasons; and to detect any circumstance which might unfairly prejudice either instrument.

The records obtained from both instruments were measured independently by Mr. Curtis and three other gentlemen, all experienced in this particular work, but neither saw the compilations of the others nor knew what results had been obtained by the other instrument for the same day. The four values secured from the records for the twelve months, June, 1896, to May, 1897, both inclusive, were as follows :

Tabulators.	A.	B.	C.	D.
	<i>Hours.</i>	<i>Hours.</i>	<i>Hours.</i>	<i>Hours.</i>
Campbell-Stokes Burning Recorder.....	1,500	1,500	1,522
Jordan Photographic Recorder.....	1,383	1,412	1,416	1,454

This shows a "personal error" in the tabulation of results from the burning recorder of only about 1 per cent, while for results from the photographic recorder the variation is from about 3 per cent to 7 per cent. This "personal error" is a refinement that has received little or no attention in the compilation of records from the Weather Bureau photographic recorders, but is shown by Mr. Curtis' experiments to be a very important matter. The Weather Bureau formerly kept a record for Washington by the burning recorder; the data has not yet been compiled but it would seem capable of being measured with a fair degree of accuracy.

As there may be differences of opinion and practice among Weather Bureau observers as to just how much of the photographic trace should be measured and tabulated, we note that Mr. James B. Jordan, in commenting upon this subject, states that it is wrong to ignore any trace, no matter how faint or indistinct. That the photographic recorder can not record too much sunshine, as the faintest trace is necessarily due to the

¹ Symons's Monthly Meteorological Magazine, December, 1897.

sun's rays, and especially, it is al

Mr. Gaster recorder was in record the fa from the pho ing washed.

son between was resorted uniform. By not believed appreciable;

sheet, as obtained instrument, it i manent before

There was the glass used chemical acti been necessar effect of this mometric sun

Mr. Curtis' viz: How mu be measured; of age on pla It gives 12-y servatories, s effect of pers

[NOTE.—A an uncertain Maring's com ation at a fe agreement be of this new t

sun's rays, and, as the washing reduces the faint traces especially, it is all the more desirable to tabulate everything.

Mr. Gaster stated that in England the photographic recorder was introduced because the burning recorder did not record the faintest sunshine, and that originally the traces from the photographic instrument were measured before being washed. The result was considered so large that comparison between records was impossible, and therefore washing was resorted to to make the records of the two instruments uniform. By using the better grades of blue-print paper it is not believed that the loss of records due to washing can be appreciable; and, with from 15 to 31 days record on each sheet, as obtained from the Weather Bureau photographic instrument, it is quite desirable to have the traces made permanent before compiling the data therefrom.

There was considerable discussion as to the deterioration of the glass used in the spheres of the burning recorders, due to chemical action, but this is a question that has not thus far been necessary to consider here, as there can be little or no effect of this kind that will impair the usefulness of the thermometric sunshine recorders used by the Weather Bureau.

Mr. Curtis' paper discusses at some length several questions, viz: How much of the trace on the sunshine records should be measured; the proper photographic chemicals; the effects of age on plates; and the effect of washing to fix the record. It gives 12-year records for the month of May at seven observatories, and shows the results of tabulations and the effect of personal equation.

[NOTE.—As the photographic recorder is apparently open to an uncertainty of 5 per cent, it is very desirable that Mr. Maring's combined photo and thermo recorder be put in operation at a few stations, in order to determine the degree of agreement between the two distinct and simultaneous records of this new type of instrument.—C. A.]