

UNIVERSITY OF CALIFORNIA LIBRARY

---

THIS BOOK IS NOT TO BE TAKEN FROM  
THE READING ROOM

---

WHEN DONE WITH, RETURN AT ONCE TO ITS  
PLACE ON THE SHELVES

LIBRARY  
OF THE  
UNIVERSITY OF CALIFORNIA.

*Class*









METEOROLOGY  
PRACTICAL AND APPLIED





# METEOROLOGY

PRACTICAL AND APPLIED

BY

SIR JOHN MOORE

J.C., M.A., M.D., D.P.H. DUBL., D.Sc. OXON. (*Honoris Causâ*), F.R.C.P.I., B.S.,

FELLOW OF THE ROYAL METEOROLOGICAL SOCIETY,

EX-SCHOLAR OF TRINITY COLLEGE, DUBLIN

SECOND REVISED AND ENLARGED EDITION

THE  
ROYAL METEOROLOGICAL SOCIETY  
LONDON



NEW YORK  
REBMAN COMPANY  
1123 BROADWAY

*All Rights Reserved*

LIBRARIAN'S FUND

TO THE  
LIBRARY



QC 861  
M6  
1910

## A FEW EXTRACTS FROM REVIEWS OF THE FIRST EDITION

### THE TIMES.

“The author gives a lucid and interesting account of modern meteorological methods.”

### DAILY EXPRESS, DUBLIN.

“If there were any real gratitude in the world Dr J. W. Moore’s extremely valuable contribution to the science of meteorology ought to be received with universal acclaim, and should quickly become the most widely read of books.”

### JOURNAL OF STATE MEDICINE.

“The book is particularly handy in size and form. The printing is clear, the illustrations numerous and well executed, and the binding distinctive. It is characteristic of the whole book that the information is precise. Dr. Moore’s work will serve as a most useful textbook to a far wider circle than that for which it is primarily intended.”

### NATURE.

“Well written and well illustrated.”

### KNOWLEDGE.

“The whole is well put together. We think Dr. Moore has given his professional brethren and his fellow-observers in meteorology a very useful work.”

### BRITISH MEDICAL JOURNAL.

“This is a good and a pretty book, and one which appeals specially to the medical profession, being the work of an accomplished physician. Among the merits of the book may be mentioned the minute and generally clear descriptions of the numerous meteorological instruments, which are very copiously illustrated.”

SCOTTISH GEOGRAPHICAL MAGAZINE.

“ Gives much valuable information.”

DAILY TELEGRAPH.

“ It may be truly said that after reading his work any person of ordinary education will be acquainted with all the leading principles of meteorological science, and will have reaped pleasure from the clearness with which technical points are explained.”

THE LANCET.

“ May be taken as a full, lucid, and satisfactory exposition of the present state of knowledge regarding the subject of which it treats. We may say that the work is well printed and handsomely illustrated.”

THE PRACTITIONER.

“ Dr. Moore has given us an attractive and useful book, which will help to popularise the study of meteorology and climatology, and we congratulate both author and publisher.”

EDINBURGH MEDICAL JOURNAL.

“ We would recommend the book as an interesting and thoroughly able treatise upon an interesting science. The volume itself, well printed and illustrated, and very tastefully bound, is indeed creditable to all concerned in its publication.”

PROVINCIAL MEDICAL JOURNAL.

“ Is brimful of information, besides being expressed in perfect, easily-understood English.”

THE IRISH TIMES.

“ As a textbook, as well as a volume of universal reference, it will take high place in contemporary scientific literature of its order.”





PLATE I.

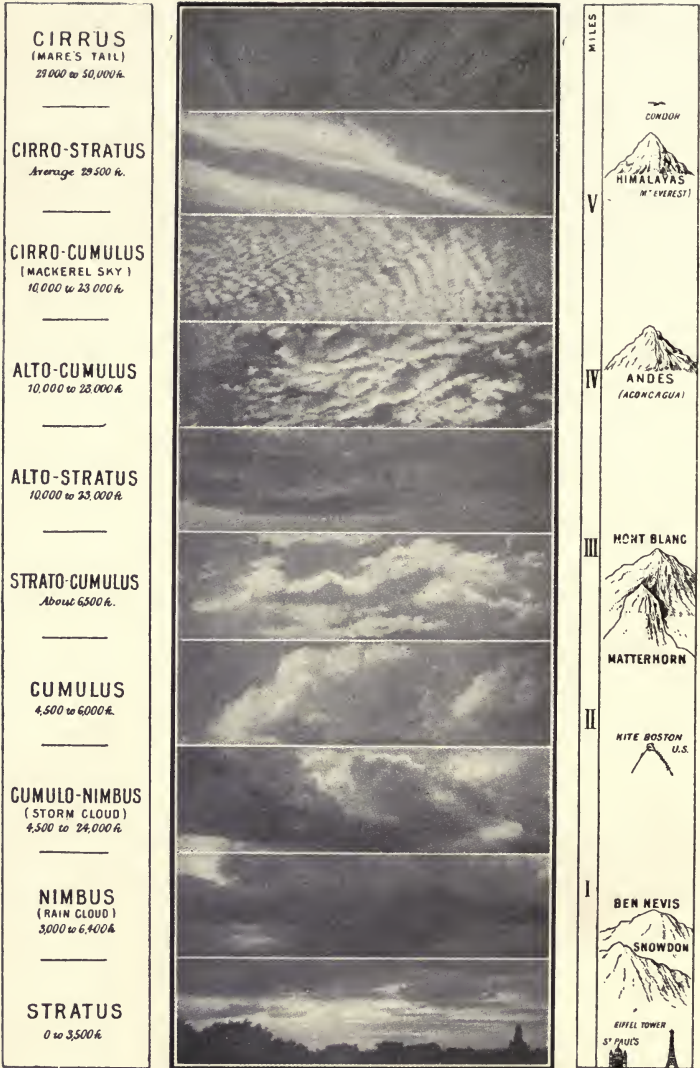

CLOUD FORMS.

(By permission of R. Inwards, F.R. Met. Soc.)

Frontispiece.

## PREFACE TO THE SECOND EDITION

WELLNIGH sixteen years have passed since the first edition of this work was published. For several years it has been out of print, but circumstances prevented me from undertaking the preparation of a second edition until some twelve months ago ; and even then the task, congenial though it was, became interrupted from time to time by the exigencies of my practice as a physician and of many collateral interests in a busy life.

The rapid progress of meteorological science at home and abroad of recent years rendered a thorough revision of the book indispensable. This it has undergone from page to page, so that it will, I trust, be found to reflect to an adequate extent the advances which have been achieved.

Some notable additions have been made to the text, especially the account, in Chapter VI., of the Meteorological Service of the Dominion of Canada, and the new chapter (XXII.) on the Investigation of the Upper Atmosphere. In order not to make the book too long or too bulky, a good deal of the historical account of the United States Weather Bureau has been omitted—not, however, in such a way as to make the description of that—the largest and most lavishly equipped meteorological service in the world—incomplete in any particular. Many new instruments are described in the several chapters, and the method of using them is explained. In many instances they are illustrated through the courtesy of their inventors or makers.

It only remains to express my grateful acknowledgments to

the many scientific friends who have helped me in my endeavour to make this book a worthy exponent of Modern Meteorology. My special thanks are due to Dr. W. Napier Shaw, LL.D., Sc.D., F.R.S., Director of the Meteorological Office, London, and the members of the staff of that Office—in particular, to Mr. R. G. K. Lempfert, M.A., Superintendent of the Statistics and Library Branch ; also to Dr. Hugh Robert Mill, D.Sc., LL.D., Chief of the British Rainfall Organisation, who was good enough to read and criticise the chapters on the Atmosphere of Aqueous Vapour ; to Mr. Ernest Gold, Reader in Meteorology in the University of Cambridge ; to Mr. R. F. Stupart, the Director of the Meteorological Service of Canada ; and to Mr. William Marriott, F.R.Met.Soc., Assistant Secretary of the Royal Meteorological Society, and author of an admirable handbook entitled *Hints to Meteorological Observers*, prepared by him under the direction of the Council of that Society—a work which I have laid under heavy contribution to my pages.

The very full Index of Subjects and Places and the Index of Proper Names have been compiled with much care by my son, William E. A. Moore, M.A.Univ.Dubl., and will, I think, be found of great use for reference. He has also helped me by reading the proof-sheets as they went through the press.

It will be observed that the volume is copiously illustrated. For this I am indebted to the liberality of the publishers, Messrs. Rebman, Ltd. ; to the Controller of His Majesty's Stationery Office ; to the Meteorological Office and the Council of the Royal Meteorological Society ; to various leading firms engaged in the manufacture of meteorological instruments ; and to Mr. F. Holmes, of Mere, Wiltshire, for the photograph of a flash of lightning taken by its own light in May, 1906. Lastly, my thanks are due, and are hereby accorded, to Dr. W. N. Shaw for the plate illustrating his model of the block of the atmospheric area under observation by *ballons-sondes* on July 27 and 28, 1908. This ingenious model is described at p. 336. The illustration of Cloud Forms is taken from *Weather Lore*, by kind permission



of the author, R. Inwards, Esq., and the original photographs were taken by the late Colonel Saunders.

In conclusion, I crave the indulgence of the readers of this book, and ask them to pardon its shortcomings, of which no one is more conscious than I am myself.

JOHN WILLIAM MOORE.

40, FITZWILLIAM SQUARE, WEST,  
DUBLIN,  
*Empire Day, May 24, 1910.*



## EXTRACT FROM THE PREFACE TO THE FIRST EDITION, 1894

THE writing of this book has been to me a labour of love. Should the reader derive some pleasure as well as information from the perusal of its pages, the task set before me will not have been undertaken and completed in vain.

It may be objected that a work on Meteorology should more fitly have been written by an author distinguished for scientific attainments, and whose life-work lay amid the precise sciences. A physician, it may be said—and said with truth—is daily and hourly exposed to distractions of all kinds in the practice of his profession. He is, in consequence, placed at a disadvantage when he discusses a purely scientific topic.

In answer to such an objection it may be urged with some force that the physician of all men has the fullest opportunities of observing the far-reaching influence of weather and climate upon human health, happiness, and longevity. If he utilises these opportunities with intelligence and zeal, he is bound to make of such topics a peculiar study. That this often happens, a reference to the Roll of Fellows of the Royal Meteorological Society or of the Scottish Meteorological Society will abundantly prove. In my own case, more than thirty years ago I was already a systematic observer of the weather, and such I continue to be. My "Second Order Station" and the lessons it has taught through all these years afford the needed foil to my more serious professional studies and pursuits. Hence it happens that

I have been able to bring no small practical experience of meteorology to bear in the writing of the pages which follow.

The work is divided into four parts. A brief introduction is succeeded by a full account of the methods which are employed in practical meteorology. The third part treats of climate and weather—necessarily in a somewhat condensed and concise manner. Finally, I have endeavoured to point out, in the fourth and concluding portion of the book, a few of the practical bearings of the subject. In those closing chapters the grave question of the influence of weather and season upon disease is in some measure discussed.

The time seems opportune for the publication of a popular yet scientific Textbook of Meteorology. The marvellous advances of Preventive Medicine within recent years, the institution of a registrable qualification in Public Health or State Medicine in the United Kingdom of Great Britain and Ireland, the establishment of a new order of public servants drawn from the ranks of the medical profession—I allude to Medical Officers of Health—the vast development of international telegraphy in modern times, the hearty co-operation of the various national Weather Bureaux—all these things have done much within the last quarter of a century to raise Meteorology to the rank of a science, and have given a wonderful impetus to the continuous or the periodic study of the weather. The literature of the subject is therefore daily increasing, and volume after volume is being added to the list of standard works on Meteorology and Climatology.

Primarily intended for the use of my professional brethren at home and abroad, this book has been so written as to claim the attention of a much wider circle of readers. Its chief object is to convey a clear idea of the Science of Meteorology to anyone of ordinary mental capacity and fair education who had been previously quite unacquainted with so attractive a study. Technical and scientific terms have been as far as possible explained. No pains have been spared to make the description of the different instruments used by meteorological observers as clear as can be.

In most instances drawings of these instruments have been interpolated in the text. . . .

Having said so much, I lay down my pen in the full confidence that the indulgent reader will, in the fascination of the subject, overlook the faults and imperfections of my work, and accept it as the outcome of many years' close observation and attentive study.

JOHN WILLIAM MOORE.

6 40, FITZWILLIAM SQUARE WEST,

DUBLIN,

*September 20, 1894.*



# CONTENTS

## PART I.—INTRODUCTORY

### CHAPTER I

#### METEOROLOGY

	PAGES
Meaning and History of the Term—Relations of Meteorology to Medicine—Buys Ballot's Law—Theory of the Winds—Cyclonic and Anticyclonic Systems—Direction and Force, or Velocity, of the Wind—Barometrical Gradients—Mr. Ernest Gold's Research on Barometrical Gradient and Wind Force—Seasonal Variations of Temperature and Air Movements—The Claim of Meteorology to be regarded as a Science . . . . .	1-10

### CHAPTER II

#### THE PHYSICAL PROPERTIES OF THE ATMOSPHERE

The Atmosphere : what it is, and its Effects—The Inclination of the Earth on its Axis—The Revolution of the Earth round the Sun—Atmospheric Air is Transparent, but has both Substance and Colour—Weight of the Atmosphere—Its Gaseous Condition—It is capable of Compression and of Expansion (Elasticity)—Professor Dewar's Experiments on the Liquefaction of Gases by Cold—Liquid Air—Liquid Oxygen—Frozen Air—Boyle's and Mariotte's Law—The Law of Charles, or Regnault's Law—Bearing of these Laws of Compression and Expansion of Gases on Practical Meteorology—Elasticity of the Air—Rarefaction of the Atmosphere at great Altitudes—Atmospheric Pressure is exerted equally in all Directions—Otto von Guericke's Experiment with the Magdeburg Hemispheres—Transparency of the Atmosphere—Its Diathermancy and Athermancy . . . . .	11-18
--	-------



CHAPTER III

THE COMPOSITION OF THE ATMOSPHERE

PAGES

Components of the Atmosphere—A Mechanical Mixture of Oxygen and Nitrogen—Argon and Helium—Nature’s Cleansing Operations—Volumetric Analysis of Air—Proofs that Air is a Mechanical Mixture and not a Chemical Combination—Sources of the Carbon Dioxide of the Atmosphere—Its Distribution—Action of Chlorophyll upon it—Ozone—Other Gaseous Constituents of the Atmosphere—Graham’s Law of the Diffusion of Gases—Mineral Constituents of the Atmosphere—Micro-organisms, or Microbes—Permanganate of Potassium Test for Organic Matter in the Air—Aqueous Vapour . . . . . 19-25

PART II.—PRACTICAL METEOROLOGY

CHAPTER IV

BRITISH METEOROLOGICAL OBSERVATIONS

Merle’s Journal of the Weather, 1337-1344—Admiral FitzRoy’s Charts and Forecasts—Synoptic Weather Charts—Meteorology of the British Isles—Stations of the First Order, or Self-recording Observatories—Stations of the Second Order (Normal Climatological Stations)—Stations of the Third Order (Auxiliary Climatological Stations)—Telegraphic Reporting Stations—Anemograph Stations—“ Isobars ” and “ Isotherms ”—Extra Stations—Royal Meteorological Society—Scottish Meteorological Society—Fernley Observatory, Southport—Daily Weather Report—Beaufort Scale of Weather—Weekly Weather Report—Monthly Weather Report—Accumulated Temperature—Numerical Scales for Telegraphic Weather Reports—Code System—Meteorological Conditions which influence Disease and the Death-rate—Equipment of a Second Order Station . . . . . 26-43

CHAPTER V

HISTORY, ORGANISATION, AND WORK OF THE UNITED STATES WEATHER BUREAU

Historical Sketch—Organisation—Forecasts—Distribution of Forecasts—Weather Signals—Scientific Work . . . . . 44-68

CHAPTER VI

THE METEOROLOGICAL SERVICE OF THE DOMINION OF CANADA

History—Publications—Weather Forecasts . . . . . 69-74

## CHAPTER VII

## AIR TEMPERATURE AND ITS MEASUREMENT

	PAGES
Temperature the most important Meteorological Factor—Meaning of the word “Thermometer”—History of the Instrument—Philo’s Thermoscope—Fahrenheit’s Scale—Why Mercury was selected as the Medium for measuring Temperature—Celsius’ Scale—The Centigrade Thermometer—Réaumur’s Scale—Relations of the three Scales to one another—Rules for reducing Readings of one Scale to those of another—Melting-point of Ice—Freezing-point of Water—Boiling-point of Water varies with Atmospheric Pressure and with Altitude—Definition of a Thermometer—Steps in the Construction of this Instrument	75-81

## CHAPTER VIII

## THERMOMETERS

Standard Thermometers—Ordinary Thermometers—“Displacement of Zero”—Registering Thermometers—Phillips’s Maximum Thermometer—Negretti and Zambra’s Maximum Thermometer—Defects in Maximum Thermometers—Rutherford’s Minimum Thermometer—Objections to Spirit Thermometers—Six’s combined Maximum and Minimum Thermometer—Casella’s mercurial Minimum Thermometer—Exposure of Instruments—Stevenson Thermometer Stand and Screen—The “Wall Screen”—Method of Reading the Instruments—The Sling Thermometer ( <i>Thermomètre fronde</i> )—Self-recording Thermometers, or “Thermographs”—Electrical and Photographic Thermographs—Radiation Thermometers—Mean Temperature—Average Mean Temperature	82-95
--	-------

## CHAPTER IX

## RADIATION

Heat : how transmitted—Conduction—Convection—Radiation—Solar Radiation—Terrestrial Radiation—Effect of Altitude on Temperature : how brought about—Radiation Thermometers—Black-bulb Thermometer <i>in vacuo</i> —Bright-bulb Thermometer <i>in vacuo</i> —Southall’s Helio-pyrometer—Herschel’s Actinometer—Ångström’s Electric Compensation Pyrheliometer—Pouillet’s Pyrheliometer—Richards’ Actinometer—The Wilson Radio-integrator—Grass Minimum Thermometers—Earth Temperatures—Critical Temperature at depth of 4 feet—Earth Temperature and Diarrhœal Diseases—Duration of Bright Sunshine—Sunshine Recorders	96-113
--	--------

## CHAPTER X

## ATMOSPHERIC PRESSURE

PAGES

The Barometer and its Uses—Galileo's Observation—Torricelli's Discovery—The "Torricellian Vacuum"—Principle involved in Nature's Abhorrence of a Vacuum—Fluids used in constructing a Barometer: Mercury, Water, Glycerine—Jordan's Glycerine Barometer—Estimation of the Height of the Atmosphere—Pascal's Experiments—Estimation of Mountain Altitudes by means of the Barometer—Sealing and Lettering of the Barometer—The "Weather Glass," or Wheel Barometer, of Robert Hooke—History of the Barometer	114-119
---	---------

## CHAPTER XI

## THE BAROMETER

The Mercurial Barometer—Extreme Limits of Atmospheric Pressure at Sea-level—"Torricellian Vacuum"—Attached Thermometer—Mounting of the Mercurial Barometer—Two Difficulties in the Construction of this Instrument—How they are Surmounted—"Error of Capacity"—Capacity Correction—The Fortin Barometer—The Kew Barometer (Adie)—The Siphon Barometer (Gay-Lussac)—The "Gun Barometer" (FitzRoy)—The Wheel Barometer, or "Weather Glass" (Hooke)—Self-registering Barometers, or "Barographs"—King's Mechanical Barograph—Ronald's Photographic Barograph—Redier's Mercurial Registering Barometer—Wheatstone's Electrical Barograph—The Aneroid Barograph—Transmission of Barometric Indications by Electricity (J. Joly)—Substitutes for Mercurial Barometers: the Aneroid Barometer—Its Altitude Scale—Bourdon's Metallic Barometer—The Piesmic Barometer—Measurement of Heights—The "Engineering Aneroid"—Sympiesometer—Hypsometer—Barrett's Open-scale Barometer	120-138
---	---------

## CHAPTER XII

## BAROMETRICAL READINGS

Attached Thermometer—Mounting of Barometer—Method of taking a Barometrical Observation—"Capillary Action"—Capillarity—The Vernier—Graduation of British Barometers—Corrections to be applied to Barometrical Readings: Index Error, Capacity, Capillarity, Temperature, Altitude, Gravity—Verification of a Barometer—The Cathetometer—Kew Certificate—Schumacher's
---

Formula for Reduction of Barometer Readings to 32° F.—Ordnance Datum for Great Britain—Ordnance Datum for Ireland—Table of Corrections for Altitude controlled by existing Air Temperature and Pressure—Laplace's Formula for finding the Difference in Height between Two Places—Determination of Mountain Heights by the Barometer—Correction for Gravity	139-150
---	---------

## CHAPTER XIII

## BAROMETRICAL FLUCTUATIONS

Periodic and Non-periodic Variations in Atmospheric Pressure—Regular and Irregular Variations—Regular : Diurnal and Annual—Irregular : Cyclonic and Anticyclonic—Distribution of Diurnal Variations—Explanation—Dove's Theory—Mr. Strachan's Objections—Diurnal Range of Pressure—Bibliography—Annual Variations of Pressure—Periodical Anticyclonic and Cyclonic Systems—Explanation of their Formation—Trade Winds—Irregular Variations in Pressure—Isobars : Primary and Secondary Shapes—Cyclonic and Anticyclonic—Secondary or Subsidiary Depression—V-shaped Depression—Straight Isobars—"Wedge" of High Pressure—"Col" of High Pressure—Cyclonic and Anticyclonic Systems contrasted—"Radiation Weather"—"Intensity"—Path of Cyclonic Systems—Weather Changes accompanying their Passage—"Veering," "Hauling," "Backing" of the Wind—Anticyclonic Weather : (1) in Winter ; (2) in Summer	151-164
--	---------

## CHAPTER XIV

## THE ATMOSPHERE OF AQUEOUS VAPOUR

Aqueous Vapour, or Water in a Gaseous or Aeriform State—Its Elastic Force or Tension—Influence of Aqueous Vapour on the Barometer, on the Weather—Evaporation—Fogs—Capacity of the Atmosphere for Aqueous Vapour—Atmometry, or Atmidometry—Hygrometry—Hyetometry—Determination of the Amount of Evaporation—Evaporimeters—Atmometers, or Atmidometers—Saturation—Heat made latent in Evaporation—Uses of Coolness produced by Evaporation—Amount of Evaporation—Babington's Atmidometer—Von Lamont's Atmometer—De la Rue's Evaporimeter—Richards' Self-recording Evaporation Gauge—Pickering's Standard Evaporimeter—Mr. Symons's Evaporimeter—Observations on Evaporation in Ireland by Mr. James Price, M. Eng., Univ. Dubl., C.E.—Mr. Baldwin Latham's observations at Croydon—Barton Moss Evaporation Station	165-174
---	---------



## CHAPTER XV

THE ATMOSPHERE OF AQUEOUS VAPOUR (*continued*)

	PAGES
Direct and Indirect Hygrometers—Organic and Inorganic Hygrometers—Dew-Point—Direct Hygrometers : Daniell's, Regnault's, Dines's—Trouton's Electrical—Indirect Hygrometers : Saussure's Hair Hygrometer—Trouton's Gravimetric Recording Hygrometer—The Aquameter—Chemical Hygrometer—Mason's Dry- and Wet-Bulb Hygrometer—The Psychrometer—Apjohn's Formula for calculating the Maximal Vapour Tension for the Dew-Point—Glaisher's Hygrometrical Tables—Greenwich Factors—Examples of their Use—Relative Humidity—Management of the Wet-Bulb Thermometer—Assmann's Ventilated Psychrometer—Distribution of Aqueous Vapour in the Atmosphere—"Absolute Humidity"—History of Hygrometers—Crova's Hygrometer	175-189

## CHAPTER XVI

THE ATMOSPHERE OF AQUEOUS VAPOUR (*continued*)

Hyetometry includes Seven Modes of Condensation of the Watery Vapour of the Atmosphere—Dew—Two forms of Dew : "Serein" and "Rosée"—Dr. McPherson's Theory of Dew—Hoar Frost—Silver Thaw ( <i>Glatteis, Verglas</i> )—Interference with Formation of Dew—Measurement of Dew—Mist and Fog—"Scotch Mist"—Formation of Fogs, Clouds, and Rain—Mr. John Aitken's Researches—The Influence of Atmospheric Dust—Mr. Aitken's Koni-scope—The Number of Dust Particles in the Air—How Fog or Mist forms—Dry Town Fogs—Haze—Measurement of Fog Densities	190-204
--	---------

## CHAPTER XVII

THE ATMOSPHERE OF AQUEOUS VAPOUR (*continued*)

Definition of a "Cloud"—Height of Clouds—The "Cloud Line"—Luke Howard's Classification of Cloud Forms—Upper Clouds : Cirrus, Cirro-cumulus, Cirro-stratus—Pallium (Poëy)—The Mackerel Sky—Lower Clouds : Stratus, Cumulus, Cumulo-stratus, Nimbus—Roll-cumulus—"Pocky" or "Festooned" Cloud—Cloud-slopes in Cumulus—Various meanings of the word "Nimbus"—Scud—Cloud Observations—Scale for the amount of Cloud—Characters of Thunder-clouds—Their Rapid Changes in Formation, Shape, and Density—Classification of Cloud System (Mannucci-Abercromby-Hildebrandsson)—Direction and Velocity of Clouds—The Nephoscope—Fineman's Nephoscope—Besson's Comb Nephoscope—Methods of Stating the Results of Nephoscope Observations—Professor E. G. Hill's Observations in India—Besson's Zenith Nephoscope—Besson's Spherical Mirror Nephometer	205-219
--	---------

CHAPTER XVIII

THE ATMOSPHERE OF AQUEOUS VAPOUR (*continued and concluded*)

	PAGES
Relative Amount of Precipitation as Dew and as Rainfall—Excessive Precipitation in the Khasi Hills, Assam—Mean Annual Rainfall of the World—Rainfall Observations in the Seventeenth Century—Weighing the Rainfall—Hooke's Rain-Gauge (1695)—Exhibition of Rain-Gauges by the Royal Meteorological Society in 1891—Chief Gauges in use: Meteorological Office Gauge, Symons's Snowdon Gauge, the Mountain Gauge, Symons's Storm Gauge, Crosley's Registering Gauge, Yeates's Registering Gauge, Richards' Self-recording Rain-Gauge—The best form of Rain-Gauge—Measurement of Rain—Time and Method of Observing—Variation of Rainfall with Elevation: how explained—Physical Causes of Rain—Influence of Electricity—Ionised Air—Coloured Rain—Snow—Sleet—Hail—Measurement of Snow—Theory of the Formation of Hail—Examples of Hailstorms—Soft Hail—Relative Size and Weight of Hailstones—Distribution of Rain: (1) Geographical, (2) Seasonal, (3) Diurnal—Weight and Bulk of Rain	220-263

CHAPTER XIX

ANEMOMETRY AND ANEMOMETERS

Wind: what it is and how produced—Force or Velocity of Wind depends on Barometric Gradients—Estimation of Wind Force—Beaufort Scale—Wind Direction—Bearings should be true—Variation of the Compass—Position of the Pole Star—Equation of Time—A Windrose: how determined—Calms—Anemometers: Pendulum, Bridled, Pressure Plate, Pressure on a Fluid, Velocity—Robinson's Cup—Child's "Step"—Evaporation or Temperature, Suction, Direction, Inclination, Musical, Dines's Helicoid, MM. Richards' Anémo-Cinémographe—Standard of Wind Velocity (Metres per Second)—Lambert's Formula for determining Mean Direction of the Wind—Mr. Dines's Comparative Experiments with Anemometers—Casella's Self-recording Anemometer—Storm of February 26-27, 1903—Life-History of Surface Air-Currents—Surface Trajectories of Moving Air (W. N. Shaw and R. G. K. Lempfert)	264 292
---	---------

CHAPTER XX

ATMOSPHERIC ELECTRICITY

Identity of Atmospheric Electricity and that obtained from an Electric Machine—The Electroscope—The Nature of Electricity—Atmospheric Electrical Phenomena—The Aurora—Electrical Density, Force, and Potential—Use of the Electroscope—The
--

	PAGES
Collector—The Electrometer—Coulomb's Torsion Balance— The Electrophorus—The Replenisher—The Diurnal and Annual March of Atmospheric Electricity—Its Distribution—Atmo- spheric Electric Potential or Electric Pressure—Thunderstorms : Professor Mohn's Classification—Cyclonic and Heat Thunder- storms—Geographical Distribution of Thunderstorms—Electrical State of the Upper Atmosphere - - - -	293-307

## CHAPTER XXI

### ATMOSPHERIC ELECTRICITY *(continued and concluded)*

Lightning—Thunder—Varieties of Lightning: zigzag, or forked ; diffused, or sheet ; globular, or ball lightning—Fulgurites—Prefer- ence of Lightning for certain Trees—Rapidity of Lightning— St. Elmo's Fire—Colour of Lightning—Hail—The Aurora : how caused ; its Height ; its Colour—Ozone—Lightning-conductors— The Brontometer (Symons) - - - -	308-324
---	---------

## CHAPTER XXII

### THE UPPER ATMOSPHERE

Kites first used in Meteorology in 1749 by Dr. Alexander Wilson— Benjamin Franklin's Historic Experiment (1752)—Glaisher's Balloon Ascents (September 5, 1862)—Blue Hill Observatory (1894)—Milan Commission, 1906 (M. Teisserenc de Bort)— Ballons-sondes—Dines's Light Meteorographs—International Balloon Ascents, 1907-1908—Observations at Bird Hill, Co. Limerick, 1908—Captain Ley's Observations at Sellack, Here- fordshire, 1907—British "Upper Air" Stations—Pyrton Hill, Oxfordshire (Observations by Mr. Dines)—Dr. W. N. Shaw's Model of a Block of Atmosphere, showing Isothermal Layer— Stratosphere—Troposphere—Advective and Convective Regions —Adiabatic State—Hergessell's Exploration of the Upper Atmosphere in Arctic Regions—Vertical Temperature Gradient of the Atmosphere (W. J. Humphreys)—Victoria Nyanza Expedi- tion—Investigations of Léon Teisserenc de Bort—Composition of the "Free Air"—Absolute or Metric Units - - - -	325-349
--	---------

## PART III.—CLIMATE AND WEATHER

### CHAPTER XXIII

#### CLIMATE

Meaning of the term "Climate"—Definition of Climate—Accumulated Temperature—Effect of Temperature on the Animal and Vege- table Kingdoms—Principal Factors of Climate: Latitude, Alti- tude, Relative Distribution of Land and Water—Presence of Ocean Currents - - - -	350-361
---	---------



CHAPTER XXIV

CLIMATE (*continued and concluded*)

	PAGES
Proximity of Mountain Ranges, Soil, Vegetation, Forests, Rainfall, Prevailing Winds—Antarctic Climate in 1902-1904—Cold Winds : East Wind of Spring in the British Isles, Mistral, Tramontana, Nortes of Gulf of Mexico, Pampēras, Tormentos, Etesian Winds —Hot Winds : Scirocco, Solano, Leveche, Harmattan, Kham- seen, Simoom, Hot Wind of Australia, Föhn, Leste . . .	362-377

CHAPTER XXV

THE CLIMATE OF THE BRITISH ISLANDS

Division of Climates into (1) Insular, or Moderate ; (2) Continental, or Excessive—Distribution of Atmospheric Pressure according to Season—Climate of the British Isles : (1) in Summer ; (2) in Winter—Isothermals in July and January—Features in the Climatology of Great Britain and Ireland—Sea Temperatures : in Winter and in Summer—Air Temperatures : arrangement of the Isotherms in January, April, July, and October—Atmospheric Pressure : its Monthly Distribution—Equinoctial Gales . . .	378-394
--	---------

CHAPTER XXVI

THE CLIMATE OF THE BRITISH ISLANDS (*continued and  
concluded*)

Distribution of Rainfall in the British Islands—Regions of heaviest Rainfall—How determined : Prevalent Winds, Exposure to these Winds, Mountains—Regions of Least Rainfall—Geological For- mation—Its Local Influence on Temperature—Permanent Eleva- tion of Surface—Pebble Beds, Sands, and Sandstones—Clays and Shales—Limestones—Crystalline Rocks, whether Slates or Schists —Climatological Tables for Dublin—Trinity College Meteoro- logical Observatory—Is our Climate changing ?—Dr. Thomas Rutty's Chronological History of the Weather and Seasons (Dublin) . . .	395-403
---	---------

PART IV.—THE INFLUENCE OF SEASON AND  
OF WEATHER ON DISEASE

CHAPTER XXVII

ACUTE INFECTIVE DISEASES

Introductory Remarks—Dr. William Heberden's Observations on Weather and Disease in 1797—Meteorological Factors which influence the Prevalence and Fatality of Disease : Mean Tempera-
---

ture, Rainfall, Humidity—Acute Infective Diseases : Influenza, Cholera, Diarrhœal Diseases—Seasonal Mortality from Diarrhœal Disease in Dublin for Thirty Years, 1872-1901—Dr. Edward Ballard's Researches—Influence of the Temperature of the Soil—The Critical Subsoil Temperature of 56° F. at a depth of Four Feet—Dr. E. Meinert's Observations on Cholera Infantum—Dr. Ballard's Working Hypothesis—The Bacteriology of Diarrhœal Diseases—Influence of Flies in Spreading these Diseases -	409-430
---	---------

## CHAPTER XXVIII

ACUTE INFECTIVE DISEASES (*continued and concluded*)

Influence on the Prevalence of Enteric Fever of (1) Season ; (2) Temperature and Moisture ; (3) Soil and Underground Water—Outbreaks at Terling and in Trinity College, Dublin—Seasonal Mortality from Enteric Fever in Dublin for Thirty Years, 1872-1901—Typhus Fever a Disease of Winter and Spring—Influence of Season, Overcrowding, Defective Ventilation, Temperature and Atmospheric Moisture—Seasonal Mortality from Typhus in Dublin for Thirty Years, 1872-1901—Seasonal Prevalence of (1) Smallpox ; (2) Measles ; (3) Scarlatina—Seasonal Mortality from Measles and Scarlatina in Dublin for Thirty Years, 1872-1901	431-445
--	---------

## CHAPTER XXIX

## THE SEASONAL PREVALENCE OF PNEUMONIC OR LUNG FEVER

Pythogenic Pneumonia—Seasonal Prevalence of Bronchitis and Pneumonia Compared—Pneumonia a Specific Fever	446-458
APPENDIX I :	
The Green Flash at Sunrise and Sunset	459-460
APPENDIX II. :	
Table of Corrections for reducing Barometric Readings to Standard Gravity, Latitude 45°	461
APPENDIX III. :	
Hygrometrical Tables	462-463
APPENDIX IV. :	
Conversion Tables for Observations in the Upper Air	464-465
APPENDIX V. :	
Bibliography of Snow-Rollers	466
INDEX OF SUBJECTS AND PLACES	467-486
INDEX OF PROPER NAMES	487-492

## LIST OF ILLUSTRATIONS

PLATE	PAGE
I. Cloud Forms - - - - - <i>Frontispiece</i>	
II. The Matterhorn : from the Rifflehaus - - - <i>facing</i>	203
III. Temperatures and Pressures in a Block of Atmosphere, Fifteen Miles thick, over a Portion of the British Isles, July 27 and 29, 1908 - - - - - <i>facing</i>	336
FIG.	PAGE
1. Merle's Journal of the Weather, A.D. 1337-1344 - - -	27
2. Philo's Thermoscope - - - - -	76
3. Kew Observatory Thermometer - - - - -	83
4. A, Phillips's, and B, Negretti and Zambra's Maximum Thermometers - - - - -	84
5. Rutherford's Minimum Thermometer, filled with Pure Alcohol for Ordinary Registration, Engine-Divided on the Stem -	85
6. Six's Thermometer - - - - -	87
7. Casella's Mercurial Minimum Thermometer - - -	88
8. Stevenson's Thermometer Stand - - - - -	90
9. Underground Thermometer - - - - -	97
10. Underground Thermometer - - - - -	97
11. Solar Radiation Thermometer Stand - - - - -	101
12. Richard's Actinometer - - - - -	103
13. Wilson's Patent Radio-Integrator - - - - -	104
14. Casella's Bifurcated Grass Minimum - - - - -	105
15. Symons's Earth Thermometer - - - - -	105
16. Diagram illustrating the Relation between Underground Temperature and the Death-Rate from Diarrhœal Diseases - -	108
17. The Campbell-Stokes Sunshine Recorder - - - - -	110
18. The Whipple-Casella Universal Sunshine Recorder - - -	111
19. Jordan Photographic Sunshine Recorder - - - - -	112
20. Improved Jordan Photographic Sunshine Recorder - - -	112
21. Torricelli's Experiment - - - - -	115

FIG.	PAGE
22. Readings of the Jordan Barometer - - -	117
23. Fortin Barometer - - - - -	123
24. Wallis's Arrangement for adjusting the Ivory Point - -	124
25. Kew Barometer - - - - -	124
26. Gay-Lussac Air-Trap - - - - -	125
27. Siphon Barometer - - - - -	125
28. Alfred King's Barograph - - - - -	127
29. The Aneroid Barograph - - - - -	129
30. Bartrum's Open-Scale Barometer - - - - -	131
31. Extra-Sensitive Aneroid Barometer - - - - -	132
32. The Piesmic Barometer - - - - -	134
33. Dines's Self-Recording Mercurial Barometer - - -	135
34. Field's Engineering Aneroid Barometer - - - - -	136
35. Adie's Sympiesometer - - - - -	136
36. Casella's Hypsometer - - - - -	137
37. Portable Leather Case for holding Casella's Hypsometer -	137
38 and 39. Method of Reading the Vernier - - - - -	142
40. Cathetometer constructed for the Indian Government -	145
41. Cathetometer, as used at Kew Observatory - - -	146
42. Cathetometer, 6½ Feet in Height - - - - -	146
43. Diurnal Oscillation of the Barometer in Various Latitudes -	155
44. Cyclonic and Anticyclonic Isobars - - - - -	160
45. Pickering's Standard Evaporimeter - - - - -	170
46. Daniell's Hygrometer - - - - -	176
47. Regnault's Hygrometer - - - - -	176
48. Dines's Hygrometer - - - - -	177
49. Vertical View of Dines's Hygrometer - - - - -	177
50. Mason's Hygrometer - - - - -	181
51. Crova's Hygrometer - - - - -	188
52. Sectional View of Crova's Hygrometer - - - - -	188
53. Lens in Crova's Hygrometer - - - - -	188
54. Fineman's Nephoscope - - - - -	213
55. Besson's Zenith Nephoscope - - - - -	217
56. Besson's Spherical Mirror Nephometer - - - - -	218
57. Hooke's Rain-Gauge - - - - -	224
58. Meteorological Office Rain-Gauge - - - - -	225
59. Snowdon Rain-Gauge - - - - -	226
60. Mountain Rain-Gauge - - - - -	227
61. Bradford Rain-Gauge - - - - -	228
62. Crosley's Self-Registering Rain-Gauge - - - - -	229
63. Yeates's Electrical Self-Registering Rain-Gauge - -	230
64. Casella's Recording Rain-Gauge - - - - -	231

## LIST OF ILLUSTRATIONS

xxvii

FIG.	PAGE
65. Richards' Self-Recording Rain-Gauge (Float Pattern) - -	232
66. Richards' Self-Recording Rain-Gauge (Balance Pattern) - -	233
67. Negretti and Zambra's Hyetograph (Upper Part) - -	234
68 and 69. Negretti and Zambra's Hyetograph - -	235
70. Forms of Raindrops - - - - -	241
71. Casella's Self-Recording Anemometer or Anemograph (see p. 289) -	269
72. Recording Cylinder of Casella's Anemograph (see p. 289) -	270
73. Pressure Plate Anemometer - - - - -	272
74. Dines's Patent Pressure Portable Anemometer - -	273
75. Lind's Anemometer - - - - -	274
76. Robinson's Anemometer - - - - -	275
77. Negretti and Zambra's Improved Robinson's Anemometer -	276
78. Air-Meter - - - - -	277
79. Vane of Casella's Altazimuth Anemometer - -	280
80. Casella's Altazimuth Anemometer - - - - -	281
81. Vane of Richards' Anémo-Cinémographe - - - - -	284
82. Richards' Anémo-Cinémographe - - - - -	285
83. Richards' Anémo-Cinémographe (Second Form) - - - - -	286
84. Anémo-Cinémographe in Position - - - - -	288
85. Diagram of Looped Trajectories for an "Ideal" Storm of Circular Isobars and Uniform Wind Tangential to the Isobars, travel- ling with the same Speed as the Wind - - - - -	292
86. Gold-Leaf Electroscope - - - - -	297
87. Thomson's Portable Electrometer - - - - -	301
88. Thunderstorm at Mere, May 13, 1906 (Photograph taken at 9.40 p.m.) - - - - -	309
89. Kite consisting of Two Strips of Material stretched into Quad- rangular Sails on a Lozenge-shaped Plan upon Four Transverse Bars kept apart by Two Pairs of Cross-Struts - - - - -	328
90. Dines's Balloon Meteorograph - - - - -	329
91. Recording Plate of Dines's Meteorograph - - - - -	330
92. Map showing the Positions at which Sounding Balloons sent up from Certain Observing Stations in 1907-1908 were found -	335
93. Showing the Relation between Temperature and Height obtained by the Ascents of <i>Balloons-Sondes</i> - - - - -	337
94. Diagram illustrating the Effect of the Perpendicular and the Oblique Falling of the Sun's Rays - - - - -	352
95. Mortality Curve of Enteric Fever (22 Years, 1869-1890) - -	432
96. The Mortality Curve for Smallpox (50 Years, 1841-1890) - -	438
97. The Mortality Curve for Measles (50 Years, 1841-1890) - -	441
98. The Mortality Curve for Scarlet Fever (30 Years, 1861-1890) -	443





# METEOROLOGY

## PART I.—INTRODUCTORY

### CHAPTER I

#### METEOROLOGY

THE term Meteorology is more than two thousand years old. It was first used by the philosopher Plato four hundred years before Christ, when he first described Socrates as “a sage, both a thinker on supra-terrestrial things, and an investigator of all things upon the earth beneath.” (“Σωκράτης, σοφὸς ἀνὴρ, τὰ τε μετέωρα φροντιστής, καὶ τὰ ὑπὸ γῆς ἅπαντα ἀνεξήτηκός.”—*Apologia Socratis*, cap. ii.) In his *Phædrus* the same author employed the very word ἡ μετεωρολογία in the sense of a discussion of τὰ μετέωρα—that is, things in the air, natural phenomena, the heavenly bodies—Cicero’s “supera atque cælestia.” Fifty years later the philosopher Aristotle wrote a treatise which he styled τὰ μετεωρολογικά, in which he discussed the subjects of air, water, and earthquakes, in this way approaching the modern signification of the word.

In a lecture on “The Dawn of Meteorology,” delivered before the Royal Meteorological Society on March 11, 1908, Dr. G. Hellmann, Professor of Meteorology in the University of Berlin, and Director of the Royal Prussian Meteorological Institute, tells us something of the astro-meteorological system of Mesopotamia in the period from 3000 to 1000 B.C. Our knowledge is derived from the astrological cuneiform library of Assurbanipal, discovered by Sir Henry Rawlinson, now preserved in the British

Museum, and of which some parts have been recently deciphered by Mr. R. Campbell Thompson and the Rev. Franz Xavier Kugler, S.J. The meteorological observations of the Chaldeans were apparently of a quite selective nature, referring particularly to optical phenomena, and especially to the halos. They distinguished clearly the small halo of 22° diameter, called "tarbasu," from the greater one of 45°, called "supuru." Besides, they paid much attention to clouds, winds, storms, and thunder. The Babylonians had a windrose of eight rhumbs. They counted the four cardinal points in the order South, North, East, West (*šutu, iltanū, šadu, amurra*), and by combining them with the word "and" (*u*), they formed the names for the intermediate directions—for example, *šutu u šadu* = S.E., *iltanū u amurra* = N.W., etc.

The Greeks were the first to make regular meteorological observations, as we learn from Theophrastus of Lesbos (322 B.C.). From the time of Meton, the astronomer and mathematician of Athens (432 B.C.), the general data of the weather, resulting from observations, were exhibited in the so-called *parapegmata* (*παραπήγματα*), a kind of peg almanac fixed on public columns. Fragments of such a *parapegma* were found recently at Miletus, and are now preserved in the Berlin Museum.

Originally applied to appearances in the sky, whether atmospheric or astronomical in their character, the term Meteorology is at present used in a much stricter and more scientific sense to denote that branch of Natural Philosophy which deals with weather and climate. It includes the study of the physical properties of the atmosphere, a description of the instruments of precision employed in that study, and the application of the knowledge so obtained to the elucidation of the problems of Physical Geography, the advancement of Agriculture, and the promotion of Health, as well as the prevention of Disease. To the physician the securing of these last-named ends is of course of paramount importance.

From the earliest times the relations existing between Medicine and Meteorology have been most intimate. The far-seeing Fathers of Medicine were not slow to perceive how sensitive to the changes of the weather the delicate human organism is, and

what an important bearing the study of weather-phenomena should exercise on the practice of Medicine. Two thousand two hundred years ago Hippocrates wrote: "Whoever wishes to study the healing art properly must do this—first, he must attentively consider the seasons of the year," etc.<sup>1</sup> In his other writings, also, he often recurs to this subject.

Celsus, again, in the second book of his treatise, *De Medicinâ*, says: "Saluberrimum Ver est: proxime deinde ab hoc Hiems, periculosior Æstas, Autumnus longe periculosissimus"—a statement which to this day is true to the letter as regards Southern Italy, where the words were penned. What can be more graphic than his description of the effects of a north wind, or as we may say of a "nor'-easter": "Aquilo tussim movet, fauces exasperat, ventrem adstringit, urinam supprimit, horrores excitat, item dolores lateris et pectoris, sanum tamen corpus spissat, et mobilius atque expeditius reddit!"

There is reason to believe that the suggestions thrown out by these illustrious Greek and Latin physicians were allowed to remain almost a dead-letter. Certain it is that their doctrines as to the close relation of Meteorology and of Climatology to Medicine became dimmed by the rust of time, and were neglected or forgotten.

Within comparatively recent years, however, a keen interest has been awakened in the subject. Every registered medical practitioner who enters His Majesty's service is required to study the broad facts relating to meteorological observation, and afterwards is called upon to aid in building up a science of climatology. Men like Edmund A. Parkes and Ballard in England, Stark and Sir Arthur Mitchell in Scotland, Quetelet in Belgium, Pettenkofer and Buhl in Germany, have studied the weather, and published researches on it and upon its bearing upon health. And now Meteorology, than which no science is more closely analogous to that of Medicine, takes its proper place in the curriculum and in the examination for the Diploma in State Medicine, Public Health, or Sanitary Science, which has been made a registrable qualification under Section 21 of the Medical Act, 1886 (49 and 50 Vict., cap. xlvi.).

<sup>1</sup> Περὶ Ἀέρων, Ὑδάτων, Τόπων.—"Ἱητρικὴν ὁστις βούλεται ὀρθῶς ζητεῖν, τὰδε χρὴ ποιεῖν· πρῶτον μὲν ἐνθυμέσθαι τὰς ὥρας τοῦ ἔτους," κ.τ.λ.

Professor Hellmann reminds us that in the epoch of Homer winds were still conceived as absolute beings, like gods; whereas Anaximander of Ionia, who flourished in the sixth century B.C., is the first to give a scientific definition of the wind which is still valid. He says: "Ανεμον εἶναι ῥύσιν ἀέρος, "The wind is a flowing of air."

In 1854 the Rev. Humphrey Lloyd, D.D., Provost of Trinity College, Dublin, demonstrated the cyclonic character of most of the gales experienced in Ireland,<sup>1</sup> and so foreshadowed what is now universally known as *Buys Ballot's Law*—a law on which the whole of modern meteorology turns. As applicable to the northern hemisphere, except close to the equator, this law may be concisely stated in the following terms: "Stand with your back to the wind, and the barometer will be lower on your left hand than on your right hand." Similarly, for the southern hemisphere, except close to the equator, the rule holds good: "Stand with your back to the wind, and the barometer will be lower on your right hand than on your left hand."

So long as the atmosphere is in a state of equilibrium the air is, of course, motionless or "calm"; but the moment the equilibrium is disturbed, an aerial current, which we call "wind," is generated—the air moving, or the wind blowing, from the district of greater towards that of less pressure, with the object of restoring absolute equilibrium. This, however, is in nature hardly ever attained. "The prime cause of atmospheric disturbance," says the Rev. W. Clement Ley, M.A., "is found in the unequal distribution of solar heat over the earth's surface; in the changes, diurnal and seasonal, in that distribution; and in the unequal effects thus produced on the tension of the air itself and of the vapour suspended in it."<sup>2</sup>

Experience and reflection have alike proved that air currents flowing in towards an area of low atmospheric pressure do so, not along straight lines, but in curves, so that a gyratory movement is developed round the low-pressure area. The determining cause of this phenomenon is the rotation of the earth upon its

<sup>1</sup> "Notes on the Meteorology of Ireland," *Royal Irish Academy Transactions*, vol. xxii., "Science," 1854.

<sup>2</sup> *Aids to the Study and Forecast of Weather*, p. 9. London: J. D. Potter. 1880.



axis. A given point on the equator travels round at an immensely greater speed than a similar point near either of the poles, because the equatorial point has to perform a journey of some 25,000 miles in the same space of time (namely, twenty-four hours) that a circumpolar point takes wherein to leisurely traverse a distance of perhaps only 100 miles. The actual speed at which a point is carried round with the earth as it spins on its axis is—at the equator, 1,040 miles an hour (namely, 24,900 miles ÷ twenty-four hours); in latitude  $30^\circ$ , 900 miles an hour; and in latitude  $60^\circ$ , only 520 miles an hour, or but one-half the equatorial velocity.

The result of this is that air flowing northwards from the equator outstrips the earth's surface over which it is blowing because of its greater initial velocity, and accordingly trends towards the north-eastward. In this way a south wind is deflected into a south-west wind. Conversely, air flowing southwards from the north pole lags behind the earth's surface, which is travelling from west to east with increasing speed according as the latitude diminishes; and so a north wind is deflected into a north-east wind. Supposing, then, an area of low pressure to exist between such south-west and north-east winds, it is evident that these winds must make for that centre so as to fill up its vacuum by curving: the south-west wind through south to south-east and east to the right-hand side, or the eastward, of the low-pressure area; the north-east wind through north to north-west and west to the left-hand side, or the westward of that area. In this way a circulation in a direction *against the hands of a watch* is developed round a low-pressure area, the point of lowest pressure in the *cyclonic system* so formed always lying (in the northern hemisphere) on the left-hand side.

In the case of the southern hemisphere the reverse of all this holds good. Air flowing southwards from the equator—that is, a north wind—travels faster than the surface over which it is blowing, and so it trends towards the south-eastward, becoming a north-west wind. Conversely, air flowing northwards from the south pole lags behind the earth's surface, which, as before stated, is travelling from west to east with ever-increasing speed as the latitude diminishes, and so a south wind is deflected into a south-east wind. These north-west and south-east winds,

thus formed, will curve into a vacuum or low-pressure area, in a direction *with the hands of a watch* : the north-west wind through north to north-east and east to the right-hand side, or the eastward, of the low-pressure area ; the south-east wind through south to south-west and west to the left-hand side, or the westward of that area. Thus, the point of lowest pressure in the *cyclonic system* so formed always lies (in the southern hemisphere) on the right-hand side.

Similar considerations will show that, when air flows out in all directions from an area of high atmospheric pressure, a gyratory movement, or circulation, will be developed, which will be in opposite directions to those just described in the case of each hemisphere north and south of the equator. To these high-pressure systems and circulations the term "anti-cyclonic" is applied, because they are the opposites, or antitheses, of the cyclonic systems already described. "From these considerations," writes R. H. Scott,<sup>1</sup> "we gather that round an area of low pressure in the northern hemisphere the wind will circulate, having the lowest pressure on its left, or in a direction against the hands of a watch. Round an area of high pressure in the same hemisphere it will circulate in the opposite direction, or with watch hands.

"In the southern hemisphere these conditions will be exactly reversed : the wind will move round an area of low barometer readings with watch hands, and round an area of high readings against watch hands."

It is now nearly sixty years since Professor Adolf Erman first drew attention, in *Poggendorff's Annalen* (vol. lxxxviii., 1853, p. 260), to these relations between wind and atmospheric pressure. But to the late Professor H. Buys Ballot, Director of the Royal Meteorological Institute of the Netherlands, Utrecht, belongs the credit of having first insisted on their constancy and importance—hence the law which expresses them is called "Buys Ballot's Law."

The application of this law teaches us that, in the northern hemisphere, the wind will be more or less easterly at a given

<sup>1</sup> *Elementary Meteorology*, p. 254. London : Kegan Paul, Trench and Co. 1883.



station when the barometer is higher to the north than to the south of it ; more or less southerly when the barometer is higher to the east than to the west ; more or less westerly when pressure is higher to the south than to the north ; and more or less northerly when pressure is higher to the west than to the east. The qualifying words "more or less" are used, because the wind seldom blows directly along, or parallel to, the "isobars" (Greek *ἴσος*, *equal* ; and *βάρος*, *weight*), as the lines of equal barometrical pressure are called. To these lines the wind is often inclined at an angle of some  $30^{\circ}$  or even  $40^{\circ}$ .

It is here to be clearly understood that these statements are in general terms, and do not apply to the actual path traversed by a given mass of air in a vast system of atmospheric movement, whether cyclonic or anticyclonic. Such a path has been called by Dr. W. N. Shaw, F.R.S., Director of the Meteorological Office, London, a "trajectory of moving air." His views are stated and explained at p. 291.

From the foregoing considerations it follows that the *direction* of the wind, or the point from which the wind is blowing, is determined by differences in atmospheric pressure, which are recorded and gauged by differences in the height of the barometer.

But, further, the *velocity* or *force* of the wind—measured by the Beaufort scale, which will be afterwards explained—is found to depend mainly on the amount of those differences, or on what are called the "barometrical gradients." The term "gradient" is borrowed from the language of engineering. Engineers measure the steepness of a slope or "incline" by the relation which its vertical height bears to its horizontal length. If the ground rises or falls 1 foot in a distance of 60 feet, they speak of the gradient as 1 in 60.

It is to Mr. Thomas Stevenson, C.E., of Edinburgh, that we owe the application of the term "gradient" to differences of atmospheric pressure as measured by barometrical observations at neighbouring or even distant stations. But barometrical gradients differ from engineering gradients in a very important particular—namely, that their vertical and horizontal units of scale are not of the same kind. Their "vertical scale," says the Hon. Ralph Abercromby, F.R.Met.Soc., "is expressed in units

of barometrical readings, and the horizontal scale in units of geographical measurement.”<sup>1</sup> In the Meteorological Office, London, barometrical gradients are now expressed in decimal parts of an inch of mercury per 15 nautical miles, or about 17 statute miles, the line joining the points of barometrical observation necessarily running at right angles to the isobars. This unit of distance—15 nautical miles—was adopted by the Permanent Committee of the International Meteorological Congress, held at Vienna in 1873, in order to secure uniformity between the gradients of the British scale and those expressed in terms of the metric system. As a hundredth of an inch is nearly equal to a quarter of a millimetre, the English gradient given above corresponds closely with a French gradient expressed in millimetres per 60 nautical miles, or 1° of latitude.

Barometrical gradients are regarded as slight or moderate when they are below .01 inch, but steep when they exceed .02 inch. They seldom exceed .04 inch or .05 inch in the British Islands. An example of the use of these barometrical gradients may be given : when it is said that on a given day there is between Dublin and Holyhead a gradient of .025 for northerly winds, it is implied that the isobars run north and south between those stations, and that the barometer stands as nearly as possible a tenth of an inch higher in Dublin than at Holyhead—there being a difference in pressure in favour of Dublin amounting to .025 inch for each unit of 15 nautical miles between the two stations—(15 × 4 = 60 nautical miles) (.025 inch × 4 = .100 inch, or one-tenth of an inch).

In general, the steeper the gradient, or the closer the isobars are on a weather chart, the greater the velocity or the force of the wind. But the direct relation between these two factors—the gradient and wind force—is often interfered with by inequalities of the earth’s surface, variations of temperature and of humidity, the existence of cross-currents in the higher strata of the atmosphere (“ the free air ”), and probably also the actual height of the barometer.

In 1908 Mr. Ernest Gold, M.A., Fellow of St. John’s College,

<sup>1</sup> *Principles of Forecasting by Means of Weather Charts*, p. 4. London : Edward Stanford. 1885.

Cambridge, Superintendent of Instruments at the Meteorological Office, London, made a highly scientific and technical report to the Director of the Office on the calculation of wind velocity from pressure distribution, and on the variation of meteorological elements with altitude. The latter portion of Mr. Gold's Report contains an account of the results obtained from kite and balloon ascents in Germany and England during 1905 and 1906, and a comparison of the values obtained for the wind velocity and direction at 1,000 metres altitude, by experiment and according to calculation. Immediately a pressure difference arises between two places, the air, if at rest before, will begin to move in the direction of the gradient. As soon, however, as it begins to move, the acceleration due to the rotation of the earth will be called into play, and the air will be deflected in a direction perpendicular to its motion. If we assume the pressure to continue steady over a considerable distance, there will come a time when the force due to the pressure gradient and that due to the earth's rotation balance one another, and keep the air moving along the isobars.

For air moving under a steady pressure system along the isobars, the relation between the pressure gradient and the velocity  $v$ , is given by the equation  $\frac{1}{\sigma} \frac{d\rho}{dn} = 2\omega v \sin \phi$ , where  $\sigma$  is the density of the air,  $\rho$  the pressure,  $n$  the normal to the isobars,  $\omega$  the angular velocity of the earth about the polar axis,  $\phi$  the latitude of the place ( $\omega = \frac{2\pi}{86164^1} = \cdot 00007292$ ).

The general result of the investigation by Mr. Gold is, in Dr. W. N. Shaw's opinion, to confirm the suggestion that the adjustment of wind velocity to the gradient is an automatic process, which may be looked upon as a primary meteorological law, the results of which are more and more apparent as the conditions are more and more free from disturbing causes, mechanical or meteorological.<sup>2</sup>

Buys Ballot's Law, as originally formulated, was supposed to apply only to those ephemeral and varying systems of atmospheric pressure which are called "cyclones" and "anti-

<sup>1</sup> *I.e.*, the number of seconds in a sidereal day.

<sup>2</sup> *Barometric Gradient and Wind Force* (Meteorological Office, No. 190). London: Wymans and Sons. 1908. Folio.

cyclones"; but it is found to be equally applicable to the far vaster and more permanent seasonal variations of pressure and wind which depend on the alternate heating and cooling of large continents, and the periodical disturbance of the balance of temperature over their surface and that of neighbouring oceans, such as the Atlantic and the Pacific. This topic will be more fitly considered at length in connection with the subject of Barometrical Fluctuations (see Chapter XIII., p. 160).

The foregoing reflections will, I trust, vindicate the claim of Meteorology to be regarded as a science—not, indeed, an exact science in the sense that mathematics and physics are exact sciences. The phenomena with which it deals are too many and too complex for that; our knowledge of those phenomena is so imperfect that we cannot systematise it so as to predict or "forecast" with certainty. But for this very reason, perhaps, the study of the weather and the elucidation of the laws which govern it possess an interest amounting to fascination, which is quite unfelt by the student of the exact sciences.



## CHAPTER II

### THE PHYSICAL PROPERTIES OF THE ATMOSPHERE

THE gaseous or aerial envelope which surrounds the earth is called the Atmosphere (Greek, ἀτμός, *vapour*; σφαῖρα, *a globe or sphere*). It profoundly influences animal and vegetable life, modifies and retains the heat derived from the sun, facilitates the transmission of sound, causes twilight or the gradual shading of day into night, and is intimately concerned in the production of weather phenomena and geological changes of all kinds.

Before we proceed to pass in review the properties of the atmosphere, it is necessary to remember that the plane of the earth's equator is inclined at an angle of  $23^{\circ}27'44''$  to its orbit of revolution round the sun, or, as it is technically called, the plane of the ecliptic—that is, the apparent annual path of the sun round the heavens, or the real path of the earth as seen from the sun. As the earth revolves round the sun year after year, the plane of the ecliptic cuts the plane of the equator (or the great circle which is equidistant from the poles and perpendicular to the earth's axis of rotation) at two points which are diametrically opposite to each other. This happens on March 21, when the sun is on the equator and going northwards, and on September 23, when the sun is again on the equator, but going southwards. The points where the ecliptic and the equator intersect are called the *equinoctial points*, and the times when this occurs are called the *equinoxes*, because day and night are then of exactly equal length, the sun being twelve hours above and twelve hours below the horizon.

From March 21 to June 21 the sun is getting farther and farther north of the equator, and remains longer and longer than twelve hours above the horizon at all places in the northern hemisphere.

On June 21 the sun appears to traverse the heavens at an angular distance north of the equator, amounting at present to  $23^{\circ}27'44''$ . He "stands still," as it were, at the Tropic of Cancer and at the summer solstice, before beginning a retrograde journey to the equator and ultimately to the southward of it. Hence the terms "solstice" (that is, *solis statio*) and "tropic" (from the Greek τροπή, a turning round). On December 21 the sun in like manner reaches his greatest southern declination—in latitude, at the Tropic of Capricorn; and in time, at the winter solstice. The expression τροπαὶ ἡελίου occurs both in Homer and in Hesiod, the latter first using the phrase as a note of time—midsummer or midwinter. Later, the two solstices—summer and winter—were distinguished by Greek writers such as Herodotus, Thucydides, Plato, and Aristotle, as τροπαὶ θεριναί and χειμεριναί respectively.

The reason why it has been necessary to enter into these particulars about the inclination of the earth on its axis, and the revolution of the earth round the sun, is that the change of seasons on all parts of the earth's surface depends chiefly upon the relations of these two factors to each other. Long days and more or less vertical suns produce summer; short days and more or less horizontal suns, on the other hand, produce winter. Summer merges into winter through autumn; winter yields to summer through spring.

Although invisible to the eye, owing to its transparency, atmospheric air has both substance and colour. That it has substance is evident from the mechanical effects which it produces when in motion. The windmill, the sailing vessel, and the anemometer alike illustrate this. The pressure anemometer has been called upon, in the gusts of great storms, to bear pressures up to 36 or even 40 pounds on the square foot. For example, a pressure of 42 pounds was recorded at Glasgow on January 24, 1868, and one of 53 pounds at Greenwich on October 14, 1881. The extraordinary pressure of over 70 pounds per square foot was registered at Bidston Observatory, near Liverpool, on February 1, 1871. This, however, must have been quite a local phenomenon, as a pressure of 49 pounds equals a velocity of  $110\frac{1}{2}$  miles per hour, and means a "hurricane that tears up trees and throws

down buildings" (Rouse). In the violent tempest of February 26-27, 1903, which wrought immense havoc to trees and buildings in the neighbourhood of Dublin and in Lancashire, a velocity of 66 miles an hour was recorded at Kingstown between 4 a.m. and 5 a.m. of the 27th; while 87 miles an hour was registered in squalls from W.S.W. at Southport at 5.55 a.m. of the 27th; and 88 miles an hour in squalls from S. by W. at Falmouth at 11.50 p.m. of the 26th.

The principle upon which the parachute is constructed, or the boomerang of the aborigines of Australia, has reference to the substantial nature of air, which is capable of resisting these bodies when passing through it.

Air, again, has weight, and can be weighed. At a temperature of 32° F., the barometer standing at 29.92 inches, 100 cubic inches of air weigh 32.6 grains nearly. The weight of a cubic foot of air is 573.5 grains. At a temperature of 60° F., and with the barometer at 30.00 inches, the corresponding weights are 30.93 grains and 534.47 grains respectively. According to Dr. Robert J. Mann,<sup>1</sup> 13 cubic feet, or a quadrangular block measuring 24 inches in two directions and 39 inches in the third, weighs exactly 1 pound; a room 10 feet square contains 77 pounds of air; while Westminster Hall holds 75 tons. He adds that air is about 760 times lighter, bulk for bulk, than water.

Under ordinary circumstances, the atmosphere exists in a gaseous state. A gas may be defined as a body whose molecules are in a constant state of repulsion. It is to the late Lord Kelvin (Sir William Thomson), who was President of the Royal Society, and Professor of Natural Philosophy in the University of Glasgow, that we are particularly indebted for a molecular analysis of air. He believed that the atoms of air were so minute that 500,000,000 of them would fit into an inch if arranged in a line. They float at some distance apart from one another, repelling each other very energetically whenever an attempt is made to drive them mechanically together. Like other gases, and, indeed, in consequence of this loose arrangement of the atoms of which it is composed, atmospheric air can be readily compressed to one-half its original volume by doubling the

<sup>1</sup> *Modern Meteorology*, p. 3. London: Edward Stanford. 1879.



pressure to which it is subjected. This fixed law of compression of gases was discovered in the seventeenth century (1662) by the Hon. Robert Boyle, F.R.S., and afterwards, independently, in 1679, by Edmé Mariotte, a priest who lived at Dijon, in Burgundy. Hence it is known as "Boyle's and Mariotte's Law." It may be concisely stated thus: *The temperature remaining the same, the volume of a given quantity of gas is inversely as the pressure which it bears.*<sup>1</sup> It will be seen, from the statement of this law, that the elastic resistance of air becomes greater and greater the more it is attempted to be compressed, whether mechanically or by means of cold. Notwithstanding this, science has triumphed, and in January, 1893, Professor Dewar, in a discourse on the "Liquefaction of Gases by Cold," delivered at the Royal Institution of Great Britain, demonstrated the liquefaction of atmospheric air. For the purpose of this experiment a temperature of not less than  $182^{\circ}$  C. ( $327.6^{\circ}$  F.) below the melting-point of ice ( $32^{\circ}$  F.) is required; in other words, the temperature must be reduced to  $-295.6^{\circ}$  F. If a vessel containing air is chilled to this extent, "the air will condense, trickle down the sides, and accumulate as a liquid at the bottom" (Sir Robert Ball, LL.D., F.R.S.). At this lecture Professor Dewar actually succeeded in pouring half a pint of liquid air from one vessel to another. The professor's subsequent experiments have been still more marvellous. He has frozen air into a viscid, jelly-like mass, something between a liquid and a solid. It is supposed that frozen air assumes this form, because oxygen—an element which appears to resist independent solidification successfully—is probably entangled in a liquid state in the frozen nitrogen of the air.

It is worth noting that liquid oxygen, also shown by Professor Dewar at his lecture, displays a beautiful blue tint, suggesting, according to Sir Robert Ball, a possible explanation of the colour of the sky—that is, of the atmosphere. To this coloration of the air allusion has already been made above.

Not only is atmospheric air capable of compression, but, in common with all gases, it is capable of expansion also. As com-

<sup>1</sup> *Essentials of Physics*, p. 61. By Fred. J. Brockway, M.D. Philadelphia: W. B. Saunders. 1892.

pression of air takes place in accordance with a fixed law, so also does its expansion. Like other gases, air increases its volume, or expands, by the  $\frac{1}{273}$ rd of its bulk for every degree of the Centigrade thermometer, or the  $\frac{1}{491.1}$ th of its bulk for every degree of Fahrenheit's scale (Regnault). When air is heated from the melting-point of ice to the boiling-point of water, it is found that 1,000 cubic inches become 1,366.5 cubic inches. The fraction  $\frac{366.5}{1000}$  or  $\frac{10.995}{30}$  (nearly  $\frac{11}{30}$ ) therefore represents the amount of the expansion of a volume of air when raised from 32° to 212° F.—that is, through 180°. But, as the expansion is equal for each degree, the amount of the expansion for 1° is  $\frac{10.995}{30 \times 180} = \frac{10.995}{5400}$ , which, when reduced, becomes  $\frac{1}{491.1}$ , as above; or in decimals, .002036 for each degree. It is to be noted that the increase of the unit of volume of a gas for 1° is called its *coefficient of expansion*. Gases are not only the most expansible of all bodies, but they all have the same coefficient of expansion—namely,  $\frac{1}{273}$  for 1° C., or  $\frac{1}{491.1}$  for 1° F. Except at very high temperatures their expansion is uniform, no matter what the temperature or the pressure may be.

The fixed formula or law just stated, by which the expanding effect of heat on a gas is expressed, was first laid down in 1787 by M. Charles, then Professor of Physics in the Conservatoire des Arts et Métiers, Paris. It was subsequently arrived at independently by John Dalton, a distinguished meteorologist, physicist, and chemist (1766-1844), whose name is especially identified with the Atomic Theory, which elevated chemistry into a science. In 1802 Louis Joseph Gay-Lussac published a memoir on the subject, and later still Regnault improved upon Gay-Lussac's experiments, so that the law is sometimes spoken of as Regnault's Law as well as the Law of Charles.

The property which air possesses of contracting in bulk when exposed to pressure, and of expanding again on the removal of that pressure, constitutes what is called elasticity—a property which air possesses in no ordinary degree.

These laws of the compression and expansion of gases have a most important and direct bearing upon meteorology. According to the law of Charles, a volume of air at a constant pressure is proportional to its absolute temperature. According to the

law of Boyle and Mariotte, the density of air varies inversely as its volume. From these two facts it follows that the density of the atmosphere is inversely as its absolute temperature—in other words, hot air is specifically lighter than cold air. This aphorism gives a clue to the origin of those great movements of the atmosphere which we call “winds.” Wherever the air becomes heated on the earth’s surface it expands, and the barometer falls. Wherever the air is chilled it contracts, and the barometer rises. By these changes in atmospheric pressure are brought about the great wind circulations which have been mentioned in Chapter I.

Another important consequence of Charles’s or Regnault’s Law is rarefaction of the atmosphere at great altitudes. Speaking in general terms, the atmosphere exerts at the sea-level a pressure of about 15 pounds (strictly speaking, 14·73 pounds) to the square inch. That is to say, a column of air one inch square, if built up from the earth’s surface to the extreme limit of the atmosphere, or to a height of some 200 miles, would weigh about 15 pounds (14·73 pounds). This weight is equal to 2,160 pounds, or nearly 1 ton, on a square foot, or 1 kilogramme on a square centimetre, or 263,000,000 tons on a square mile. A pressure of 15 pounds upon the square inch is technically spoken of as a pressure of *one atmosphere*. A column of mercury 30 inches in height and 1 square inch in section is found to weigh 14·73 pounds, and so is equivalent to the weight of a column of atmospheric air of the same section. The principle of the construction of the barometer is based upon this fact, as we shall see in a subsequent chapter. Now, if we ascend 2·7 miles, or to a little below the summit of Mont Blanc (15,781 feet), half the weight of the atmosphere will have been left below, and the barometer will read not 30, but only 15 inches. In accordance with Charles’s or Regnault’s Law, a given bulk of air will, at the height mentioned, expand to twice the volume it would have at sea-level. At a height of 5·4 miles its volume would be again doubled, and the barometer would read only 7·5 inches, and so on until at 60 miles above sea-level “the air is probably as rare as the best vacuum that can be produced by the air-pump” (R. J. Mann). The outward limit of the atmosphere must be determined by a counterpoise between gravity on the one hand and centrifugal force and the

repulsive action of the aerial molecules on the other. Where that limit lies cannot be stated with certainty, but investigations upon the duration of twilight assign to the atmosphere a height of 45 miles at the lowest estimate, and of 190 or possibly 212 miles at the highest. The latter great elevation is inferred by M. Liais, from observations upon the influence of the rarer regions of the atmosphere upon twilight at Rio de Janeiro.<sup>1</sup>

Experiments prove that atmospheric pressure is exerted equally in all directions—downwards, as already shown; but also upwards and horizontally or laterally. Otto von Guericke's classical experiment with the *Magdeburg Hemispheres*, first performed in 1650 before the Imperial Diet at Ratisbon, is conclusive on this point. Hence it is that objects near the earth's surface are not crushed by the pressure of the atmosphere—a pressure so tremendous that an average-sized man sustains a weight of some 15 tons. In this pressure of air in all directions we have a further and effective cause of air movement or wind. A column of cold air being heavier than an equal volume of warm air, its lower strata are pushed towards the area where atmospheric pressure is less, or towards the area of warm and therefore lighter air. The wind, in other words, blows from the area of high barometer towards that of low barometer, not, indeed, in a straight line, but anticyclonically, as explained in Chapter I.

The atmosphere, when pure and dry, possesses two further remarkable properties—*transparency* and *diathermancy*. Transparency means that pure air is permeable to the vibrations of *light*. In consequence, we are able to scan the heavens in one direction and to study the effects of light as broken up into colour on the earth in the other direction. When aqueous vapour intervenes, we gaze with admiration on the glories of sunrise and of sunset, which are due to diffraction of light, absorption of the blue rays of the spectrum taking place because their wavelengths are small, while the yellow and red vibrations of greater length are allowed to pass through the aqueous vapour and so are reflected to earth.

Diathermancy (Greek, *διάθερμος*, *thoroughly warm*) is the property whereby radiant heat, such as that of the sun's rays,

<sup>1</sup> *Comptes Rendus*, tome xlviiii., p. 109.



may be transmitted through a medium without raising its temperature to any great extent, and this property dry air possesses in a remarkable degree; it is so freely permeable to radiant heat that both at great altitudes, as on the snow-covered Alps, and in high latitudes, as within the Arctic and Antarctic Circles, the sun's rays may be of extraordinary power, provided only that the atmosphere is extremely dry. Dr. R. H. Scott says:<sup>1</sup> "The observation is as old as the time of Scoresby, that on board a whaler you may see the pitch bubbling out of the seams of the ship where the sun shines on them, while ice is forming on the side of the ship which is in shade." It has been computed that the sun's rays lose, under ordinary circumstances, 20 per cent. of their heat by absorption while passing vertically through the earth's atmosphere. The percentage of loss increases as the path of the heat rays becomes more and more horizontal, until soon after sunrise, or shortly after sunset, a condition of complete, or almost complete, *athermancy* is reached—that is, the power of stopping radiant heat (corresponding to opacity as regards light), is greatest, the heat rays being entirely intercepted by the dense, damp strata of the atmosphere, at sunrise and sunset.

The heat waves from the sun are long and short. The long waves are absorbed as they pass through the atmosphere towards the earth. The short waves reach the surface, whence they are reflected or radiated back again in lengthened waves, to meet their fate at last in absorption by the aqueous vapour of the atmosphere. In this way radiation into space is checked, and life is preserved upon the face of the globe.

In the British Islands diathermancy is most decided during the prevalence of clear skies and dry easterly winds in spring and early summer; it is least marked during the prevalence of damp fogs and mists in late autumn and the winter season of the year.

<sup>1</sup> *Elementary Meteorology*, p. 57. 1883.

## CHAPTER III

### THE COMPOSITION OF THE ATMOSPHERE

CAREFUL volumetric analysis shows that atmospheric air consists almost entirely of a mechanical mixture of oxygen and nitrogen (including argon), together with a small and variable quantity of carbon dioxide or carbonic acid ( $\text{CO}_2$ ). There is also present in the air moisture or aqueous vapour, the amount of which varies, especially with the temperature. Peroxide of hydrogen and nitrous and nitric acids are occasional components; so is sulphurous acid in the vicinity of large towns. Besides the foregoing, very minute traces of ammonia, as well as of sulphide of hydrogen or its ammonia compound, and of helium, besides a variable quantity of organic matter derived from the animal, vegetable and mineral kingdoms, are commonly present in those strata of the atmosphere which are nearest the earth's surface at sea-level.

The air is purest on the summits of lofty mountains, on open prairies or moorlands, in Arctic regions, and in mid-ocean. It is temporarily purified by gales and thunderstorms, downpours of rain, copious dews and heavy falls of snow or hail—all of them great cleansing operations of Nature which the Germans expressively call "Niederschläge" (precipitations). (Cornelius B. Fox).

The most elaborate volumetric analyses of air have been made by Dr. Angus Smith, Bunsen, and Regnault. In a series of fifteen analyses, Bunsen found the oxygen *by volume* to vary from 20·970 to 20·840 per cent. Regnault's examinations of air from different parts of the world gave very similar results—20·940 to 20·850 per cent. In country air he occasionally found the percentage volume of oxygen to rise to 21·000. On one occasion

the air of Paris yielded 20·999 of oxygen by volume per cent. Angus Smith, in twenty-two examinations, found 20·938 per cent. of oxygen in the most crowded parts of Perth; while the air of the heath and of the seashore gave 20·999. For all practical purposes the percentage volume of nitrogen (including argon) in the air may be found by subtracting the foregoing figures from 100, for carbon dioxide is present only in quantities ranging from ·025 to ·045 per cent., or 25 to 45 per 100,000 parts by volume.

In order easily to remember the composition of the atmosphere by volume and by weight we may say that in 100 parts there are of—

	Volumes.	Grains Weight.
Oxygen .. .. .	20·96	23·10
Nitrogen .. .. .	77·70 <sup>1</sup>	76·84
Argon .. .. .	0·80	—
Carbon dioxide .. .. .	0·04	0·06
Aqueous vapour .. .. .	0·50 <sup>2</sup>	—
	100·00	100·00

It is right also to mention that, in analyses by *weight*, the percentage weights of oxygen and nitrogen may be translated into percentage volumes by dividing the respective specific gravities of these gases into their respective percentage weights. The specific gravity of oxygen is 1·10561; that of nitrogen is 0·97135.

Atmospheric air is not a chemical combination of oxygen and nitrogen. It is simply a mechanical mixture, in which the molecules of oxygen are separate and distinct from those of nitrogen, through which they vibrate at inconceivable speed without let or hindrance of any importance. Only when the nitrogen molecules are so compressed by cold as to form a liquid or a solid is the free play of the oxygen molecules so far interfered with as to lead to the formation of the viscid jelly-mass which represents atmospheric air when frozen solid.

That air is a mechanical mixture and not a chemical combination is proved by the following considerations:

1. There is no chemical formula for air, for the relative proportions of oxygen and of nitrogen present in it are not those of their combining weights, or of any simple multiple of those weights.

<sup>1</sup> May fall to 77·16.

<sup>2</sup> May rise to 1·04.



2. When air is artificially made by mixing oxygen and nitrogen together in proper proportions, no change of volume takes place, nor is heat or electricity disengaged as in the production of ordinary chemical combinations.

3. Air is slightly soluble in water, but oxygen dissolves more readily than nitrogen. If water, in which air has been dissolved, is boiled, the air which is expelled is found to contain nearly 35 per cent. of oxygen, instead of only 21 per cent. The air has been oxygenated to the amount of 14 per cent. This could not happen if air was a stable chemical compound.

4. The refraction of air is the mean of the refraction of oxygen and of that of nitrogen. If air was a chemical compound, it would have a refraction of its own, not the mean refraction of its constituent gases.

Carbon dioxide is a normal constituent of the atmosphere. The table given above shows that it forms 4 out of every 10,000 volumes of air, and weighs 6 grains out of every 10,000 grains of air. If it exceeded this amount to any great extent, it would poison animal life; if it fell short of this amount, the vegetable kingdom would starve.

The carbon dioxide of the atmosphere is derived from—

1. The soil and subterranean sources generally.
2. The respiration of animals.
3. Combustion.
4. Fermentation and decomposition.
5. The burning of limestones in lime-kilns.
6. Carbonated natural mineral waters.

Experiments prove that on land the quantity of carbon dioxide in the air is greater by night than by day, because so much of the gas is exhaled by plants at night. It increases after rain and towards midday. At sea, it is greater by day (5 volumes per 10,000) than by night (3 volumes per 10,000). M. Méné<sup>1</sup> found that the highest percentage of the gas in the air was in October, and that its amount falls to a minimum in December, January, and August. Risler<sup>2</sup> arrived at somewhat analogous results

<sup>1</sup> *Comptes Rendus*, lvii., p. 155.

<sup>2</sup> *Ibid.*, xciv., pp. 1390, 1391.

from investigations at Nyon, Switzerland. Frankland,<sup>1</sup> Angus Smith, and M. G. Tissandier<sup>2</sup> all found larger quantities of the gas at considerable elevations than lower down at medium heights. Frankland's experiments were made at the summit of Mont Blanc; Tissandier's in a balloon. At moderate elevations, however, the quantity of carbon dioxide is not so great as on the ground or at sea-level.

The composition of the atmosphere, as regards oxygen and carbon dioxide, is maintained by the action of chlorophyll—the green granular matter formed in the cells of the leaves of plants—which, under the influence of sunlight, has the extraordinary power of splitting carbon dioxide up into its two constituents—*carbon*, which it retains, and *oxygen*, which it exhales (Wynter Blyth).

*Ozone* (Greek ὄζω, *I have a smell*) is a colourless, gaseous substance, with a peculiar smell like weak chlorine, which is developed as the immediate result of electrical disturbances. Houzeau has experimentally demonstrated its amount in country air to be 1 volume in 700,000 volumes of air. It is absent in cities, in crowded dwelling-rooms, and over marshes. Unfortunately, the tests for it react to other substances in the atmosphere, such as hydrogen dioxide (peroxide of hydrogen) and nitric acid. The whole subject, however, of ozone and of ozone-testing will more fittingly be considered in Chapter XXI. on Atmospheric Electricity (see p. 321).

The element *argon* (atomic weight = 40) was discovered in 1894 by Lord Rayleigh, F.R.S., O.M., and Sir William Ramsay, K.C.B., F.R.S., who described it as a probably inert constituent of the atmosphere; hence its name from the Greek ἀ, privative, and ἔργον, *work*. It shows little affinity for other elements, and is a constituent of atmospheric air to the amount of 0.8 per cent. in volumetric proportion. *Neon*, *krypton*, and *xenon* are three newly discovered atmospheric gases, to which attention has been drawn by Sir William Ramsay.

Traces of *helium* (atomic weight = 4) are also present in atmospheric air. This element receives its name from the Greek

*Journal of the Chemical Society*, 1861.  
*Comptes Rendus*, April 12, 1875.

word ἥλιος, *the sun*, because at the time when it first attracted attention it was supposed not to exist upon our earth. In 1895, however, it was discovered to be also a terrestrial element by Sir William Ramsay, and since then it has been recognised as one of the products given off by radium and as a constituent of certain minerals.

The other gases which are more or less constantly present in the atmosphere have already been named. *Nitric acid* is generally present in minute quantities. *Sulphurous acid* is derived from the combustion of coal in large towns. From experiments undertaken at Lille, A. Ladureau<sup>1</sup> found that it increased in amount during calm weather, while it equally decreased on stormy days.

Mr. Horace T. Brown estimates the normal amount of *ammonia* present in the air to be about 6 parts per 1,000,000. Heavy rain lessens the amount for a time.

The presence of *hydrogen sulphide* in the atmosphere of large towns is proved by the tarnishing of silver plate and coins. It may be present as ammonium sulphide.

Besides carbon dioxide, *marsh-gas* is always present in the air, although in minute quantities. Its chemical formula is  $\text{CH}_4$ . It is a product of decomposition of organic matter in stagnant pools. Hence its name. It is also called *methane*, and constitutes the *fire-damp* of coal-mines.

These gases diffuse freely through the atmosphere in obedience to a fixed law, which is that the diffusibility of two gases varies in the inverse ratio of the square roots of their densities. This law of the diffusion of gases, commonly called "Graham's Law," is based upon a consideration of the size and velocity of repulsion of the molecules of each gas. If one molecule, say of oxygen, weighs sixteen times as much as another, say one of hydrogen, then the latter has to move four times as fast as the former in order to strike as effective a blow. Hydrogen, a light gas, diffuses four times as fast as oxygen, a heavy one. The rate of diffusion is in this instance inversely as the square roots of one and sixteen.

"The process of diffusion," says Professor Miller in his *Chemical*

<sup>1</sup> *Ann. Chem. Phys.* 5, xxix., pp. 427-432.

*Physics*, "is one which is continually performing an important part in the atmosphere around us. Accumulations of gases which are unfit for the support of animal and vegetable life are by its means silently and speedily dispersed, and this process thereby contributes largely to maintain that uniformity in the composition of the aerial ocean which is so essential to the comfort and health of the animal creation. Respiration itself, but for the process of diffusion, would fail of its appointed end, in rapidly renewing in the lungs a fresh supply of air in place of that which has been rendered unfit for the support of life by the chemical changes which it has undergone."

Among mineral constituents of the atmosphere *common salt* (sodium chloride) is the most frequently met with, especially in the lower strata of the air. Spectroscopic analysis of the Bunsen flame invariably gives the sodium line in consequence of the presence of the salt. *Metallic dust* of various kinds abounds in the vicinity of manufactories and in the air of mines.

Vast numbers of *micro-organisms*, or *microbes*, infest the air. These belong both to the pathogenic and to the non-pathogenic groups. They are infrequent in the air of mid-ocean and on high mountains, but abound in the air of towns, swarming in that of ill-ventilated dwelling-rooms. Mr. J. B. Dancer,<sup>1</sup> F.R.A.S., examined the solid particles of the air of Manchester microscopically, and came to the conclusion "that 37½ millions of these bodies [particles of both organic and inorganic origin], exclusive of other substances, were collected from 2,495 litres = 88 cubic feet, of the 'air of Manchester,' a quantity which would be respired in about ten hours by a [man] of ordinary size when actively employed."

According to Mr. A. Wynter Blyth<sup>2</sup>, the best chemical method of estimating organic matter in the air is its approximate estimation by means of permanganate of potassium. A known bulk of air is drawn through a little distilled water, and the amount of oxygen consumed is determined by the Forchammer process. Ten cubic centimetres of a standard solution of permanganate

<sup>1</sup> *Proceedings of the Literary and Philosophical Society of Manchester*, vol. iv. Series 3. 1867-1868.

<sup>2</sup> *A Manual of Public Health*, p. 96. 1890.



of potassium,<sup>1</sup> and ten cubic centimetres of sulphuric acid, diluted to one-third, are added to a known bulk of water—say a litre. The whole is then heated for four hours to 80° F. (26·6° C.). At the end of that time the water is titrated—that is, has its strength determined—with a hyposulphite solution made by dissolving one part of crystallised sodic hyposulphite in a litre of water, using iodide of potassium and starch as an indicator. The value is obtained by running a control with distilled water.

One of the most important constituents of the atmosphere is *aqueous vapour*, or water in a gaseous or aeriform state. A vapour, like a gas, is subject to the laws of expansion and of compression, which have been already discussed in these pages—but only *within certain limits*. “If,” says Dr. R. H. Scott,<sup>2</sup> “these limits be overpast—*i.e.*, if the pressure becomes too great or the temperature falls too low—a portion of the vapour will pass into the state of liquid. Under any circumstances of pressure and temperature, a given space can contain only a given quantity of vapour. This is as true of vapour mixed with air as of vapour by itself.”

The overwhelming influence of aqueous vapour in practical meteorology arises in part from its sensitiveness to the action of heat—even moderate changes of temperature causing it to expand or contract, to evaporate or condense, with great facility; but more especially from its liability to pass from the gaseous or vaporous, to the liquid or even solid form, at temperatures of everyday occurrence in Nature. It is, however, to the marvellous heat-absorbing powers of aqueous vapour that the attention of the practical meteorologist must in particular be directed, when he seeks an explanation of the phenomena of what we call “Weather.”

<sup>1</sup> Made by dissolving 0·395 gramme of potassic permanganate in a litre of water. Each c.c. contains 0·0001 gramme of available oxygen.

<sup>2</sup> *Elementary Meteorology*, p. 95. 1883.

## PART II.—PRACTICAL METEOROLOGY

### CHAPTER IV

#### BRITISH METEOROLOGICAL OBSERVATIONS

THE earliest known Journal of the Weather was that kept at Oxford by the Rev. William Merle, Fellow of Merton College, and afterwards Rector of Driby, Lincolnshire, during the seven years 1337-1344. His "Consideraciones Temperiei pro 7 Annis" were discovered in a MS.<sup>1</sup> in the Bodleian Library, Oxford, in 1891, and were immediately afterwards reproduced and translated under the supervision of the late Mr. G. J. Symons, F.R.S., to whom British meteorology owes so much (Fig. 1). The observations are climatological, and are written in Latin in Old English characters. They represent the primeval stage of weather study, in which popular weather prognostics came to be drawn from daily scanning of the heavens, untiring observation of the movements of animals, including the arrival and departure of migratory birds, of the leafing and flowering of trees and shrubs, of the ripening of harvests and fruits, and of the fall of the leaf in autumn. These phenological observations in bygone days conferred a marvellous power of forecasting weather, and so they do at the present day also, so far as local districts are concerned.

Since the discovery of the barometer in the seventeenth century, isolated observations on atmospheric pressure—crude, no doubt, and unreduced to any standard altitude or temperature—afforded an increased power of weather forecasting.

It was not, however, until 1861 that the systematic application

<sup>1</sup> Digby MS. 176, fol. 4.



of telegraphy to the synchronous study of the weather at distant stations revolutionised meteorology and raised it to the dignity of a science. The service of Daily Weather Charts and Forecasts, which was inaugurated in France by M. Le Verrier and in England by the late Admiral FitzRoy in the year named, has been amplified and improved since then, but to them belongs the credit of organising a system of weather study which now extends over the whole civilised world. Every country in Europe; Egypt; Canada, the United States, and the Argentine Republic; India,

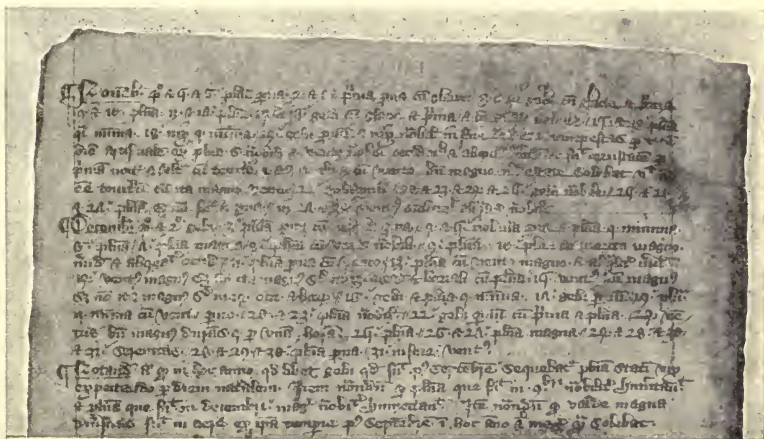

FIG. 1.—MERLE'S JOURNAL OF THE WEATHER, A.D. 1337-1344.  
(Reproduced by permission of the Royal Meteorological Society.)

Japan, China, Australia, and New Zealand—all have their Meteorological Offices or Weather Bureaux, in which synoptic weather charts and forecasts are prepared at least once a day.

The word "synoptic" (Greek *συνοπτικός*, from *σύνοψις*, a seeing all together, a general view) signifies that the weather chart has been prepared from observations taken at the same moment of time over a large tract of country, and that it illustrates the type of weather prevailing throughout the district embraced in the chart at the hour of observation.

The following account of the method in which the land meteorology of the British Islands is studied through the medium of

the Meteorological Office, London, will apply *mutatis mutandis* to the Weather Bureaux of the British Colonies and of Foreign States.

The observatories in the United Kingdom in connection with the Central Office may be arranged in five classes :

1. *Stations of the First Order, or Self-recording Observatories*, which are furnished with self-registering instruments by which all the principal meteorological phenomena are recorded *continuously*. Thus, there are continuous records or hourly readings of pressure, temperature, wind, sunshine, and rain, with eye observations of the amount, form, and motion of the clouds, and notes on the weather. These alone afford the materials necessary for the study of the periodic variations of the meteorological elements. The autographic records are checked by frequent eye observations. There are six such stations at present : three in England—Falmouth, Kew, and Stonyhurst ; two in Scotland—Aberdeen and Glasgow ; and only one in Ireland—Valentia, in Kerry. The observatory at Armagh was relegated to Class II. some years ago. Observatories are also maintained at Greenwich (the Royal Observatory), Oxford (Radcliffe Observatory), Bidston (Mersey Docks and Harbour Board), Southport (the Corporation), and Berkhamsted (E. Mawley, Esq., F.R.Met.Soc.).

2. *Stations of the Second Order, or Normal Climatological Stations*.—At the end of March, 1909, the total number of these stations was 80, including 10 belonging to the Royal Meteorological Society and 13 belonging to the Scottish Meteorological Society. The stations are distributed as follows : 50 in England, 2 in Wales, 19 in Scotland, and 9 in Ireland. Reports from the Irish stations are regularly supplied to the Registrar-General for Ireland for his Weekly and Quarterly Returns. At all of these climatological stations regular eye observations are taken twice daily at 9 a.m. and 9 p.m. local time (or other accepted combinations of hours), of atmospheric pressure, temperature (dry bulb and wet bulb), wind, amount of cloud, and weather, with the daily maximum and minimum of temperature, the daily rainfall, together with general remarks on the weather. The observers at these stations are all volunteers. All the stations are regularly inspected by inspectors from the Meteorological Office.

3. *Stations of the Third Order, or Auxiliary Climatological Stations*, recording observations similar in kind to those at the Normal Climatological Stations, but either (a) less full, or (b) taken only once daily, or (c) taken at hours other than 9 a.m. and 9 p.m. On March 31, 1909, 108 stations of this order were at work for, or in communication with, the Meteorological Office—namely, 78 in England (8 reporting through the Royal Meteorological Society), 9 in Scotland (2 reporting through the Scottish Meteorological Society), 9 in Wales, and 12 in Ireland.

4. *Telegraphic Reporting-Stations*.—Twenty-nine are in the British Isles, at which the observations are taken by eye at certain hours determined by the requirements of the telegraphic system. In some cases the eye observations are supplemented by self-recording aneroid barometers, etc. Of the 29 home telegraphic stations, 13 observe at 7 a.m., 1 p.m., and 9 p.m., and thus come under the international definition of Second Order Stations. They are not, however, included in the Second Order Stations mentioned above.

5. *Anemograph Stations*, furnished with instruments registering wind only. At Armagh, rainfall and sunshine are in addition recorded. The anemograph stations furnish continuous records of wind velocity (force), and in most cases also of wind direction. The observations from these stations are important in connection with storms, and afford evidence available in courts of law relative to collisions at sea and damage done by wind either on land or at sea.

The foreign reporting-stations, 44 in number, extend along the entire western coast of the continent of Europe, from Bodö in lat. 67° N. to Lisbon in lat. 38° N. They include 4 stations on the shores of the Baltic, 5 in Iceland, 1 in the Faeroe, 4 in Germany, 1 in Central Sweden, 4 in Norway, 2 in the Azores, and 3 in the Mediterranean. The observations received from Iceland give only the readings of the barometer and of the dry-bulb thermometer, the direction and force of the wind, and the state of the weather. The telegraphic reports from the Azores are furnished through the courtesy of the Portuguese Government and of the Eastern Telegraph Company and the Commercial Cable Company.

Through the courtesy of the Lords Commissioners of the Admiralty occasional reports of observations at sea off our southern and western coasts are transmitted by wireless telegraphy from the ships of H.M. Navy.

The remaining 29 telegraphic reporting-stations are scattered throughout Great Britain and Ireland and the adjacent islands. At these stations observations are taken at 7 a.m. and 6 p.m. West European time, and are telegraphed to London according to a special cipher code, which will be hereafter explained (see p. 38). Lisbon observes at 8 a.m. local time, and the Azores at 6 a.m. local time. In addition, observations are taken at 1 p.m. daily at certain home and foreign stations, and are at once telegraphed in cipher to London. There is a home-station in St. James's Park, London.

The following table shows the stations which were working in co-operation with the Meteorological Office, London, in 1909. The facts are taken from the annual report of the year ending March 31, 1909. Particulars of the numbers of Third Order Stations are added, as these now form an important part of the Office work :

	SECOND ORDER STATIONS.			THIRD ORDER STATIONS.			TELEGRAPHIC STATIONS.	
	Total Number.	Reporting through S. Met. Soc.	Reporting through R. Met. Soc.	Total Number.	Reporting through S. Met. Soc.	Reporting through R. Met. Soc.	Telegraphic in British Isles.	Foreign Telegraphic.
Scotland ..	19	13	—	9	2	—	7	—
England ..	50	—	10	78	—	8	14	—
Wales ..	2	—	—	9	—	—	2	—
Ireland ..	9	—	—	12	—	—	6	—
Total ..	80	—	—	108	—	—	29 <sup>1</sup>	44

<sup>1</sup> Of these, 13 observe at 7 a.m., 1 p.m., and 9 p.m., and thus come under the international definition of Second Order Stations. These have not been included in the 80 Second Order Stations. The self-recording observatories are Aberdeen, Glasgow, Stonyhurst, Kew, Valentia, Falmouth. As has already been stated, observatories are maintained independently of the Meteorological Office at Greenwich, Oxford, Bidston, Southport, and Berkhamsted.



As the reports come in, the information is entered on a chart, which is preserved in the Office, and from which the Daily Weather Report is prepared. This Report fills four large quarto pages, and is arranged as follows :

Page 1 contains the whole of the sixty-six reports from which the maps for the day (given on page 2) are prepared, and the 6 p.m. reports of the previous day, together with the maximum and minimum temperatures of the air, the rainfall for the previous twenty-four hours, and for the home stations the previous day's sunshine, when available.

Page 2 contains (1) a chart of North-Western Europe, showing, for 7 a.m. on the date of publication, the distribution of atmospheric pressure, the prevalent winds, and the sea disturbance, with necessary explanations, together with a table showing the mean temperature for the month at 8 a.m., derived chiefly from observations extending over the thirty-five years, 1871-1905 ; (2) supplementary charts showing the state of the barometer and the direction of the wind at 7 a.m. and also at 6 p.m. of the previous day ; and (3) notes on the general situation at 7 a.m.

Page 3 contains (1) a similar chart of North-Western Europe, giving the distribution of temperature at 7 a.m., and the weather prevailing at each station, expressed by letters of the Beaufort Scale, explained below ; (2) notes on the weather of the previous day, together with the general inference to be drawn from the 7 a.m. observations ; (3) a small map of the Forecast Districts of the British Isles, with an explanation of the storm-signals which are exhibited on our coasts as required ; and (4) forecasts for the twenty-four hours commencing at noon of the day of observation. These forecasts are drawn up for each of the eleven Forecast Districts of the British Isles, and indicate the weather likely to be experienced within the coming twenty-four hours.

On the Weather Charts, on pages 2 and 3, lines are drawn through the places where atmospheric pressure and temperature are respectively equal. The lines of equal pressure are called "isobars" (Greek *ἴσος*, *equal* ; *βάρος*, *weight*) ; those of equal temperature are called "isotherms" (Greek *ἴσος*, *equal* ; *θέρμη*, *warmth*). Isobars are by far the most important element in forecasting, while isotherms play a very subordinate part. The

direction of the wind is marked by arrows, which fly with the wind. They carry a number of "flèches" proportional to the force of the wind estimated by the Beaufort Scale (see p. 39). The readings of the barometer are corrected for the difference in Gravity between the position of the station and latitude  $45^{\circ}$ .

Page 4 contains information as to (1) the temperature, weather, sunshine, and rainfall recorded at a large number of British and Irish stations on the afternoon or in the evening of the previous day; (2) the temperature, weather, and rainfall at a number of additional foreign stations, mainly for the twenty-four hours ended at 7 a.m. of the previous day; and (3) wireless telegrams received from H.M. ships, or from British and foreign transatlantic liners, during the twenty-four hours ended at 9.30 a.m. of the day of observation.

The information relating to weather is indicated by the following letters, which constitute the "Beaufort Scale" of Weather: *b*, blue sky; *bc*, sky half clouded; *c*, sky three parts clouded; *d*, drizzling rain; *e*, wet air, without rain falling; *f*, fog; *g*, gloomy; *h*, hail; *l*, lightning; *m*, misty (hazy); *o*, overcast; *p*, passing showers; *q*, squally; *r*, rain; *s*, snow; *t*, thunder; *u*, ugly, threatening; *v*, visibility, unusual transparency; *w*, dew; *x*, hoar-frost; *z*, dust-haze, or smoke.

Records are also received from various additional barograph stations, additional thermograph stations, additional autographic rain-gauge stations, some sixty-one sea-temperature stations, kite or balloon stations furnishing observations of temperature, humidity, and wind in the upper air; while a hygrograph station at Newnham College, Cambridge, sends in a continuous record of the relative humidity of the air.

The headquarters for the investigation of the upper air are situated at Pyrton Hill, Oxfordshire, where Mr. W. H. Dines, F.R.S., has equipped a station for pursuing this branch of meteorological research by means of kites and balloons. The subject will be discussed fully in a subsequent chapter (see Chapter XXI.).

A continuous record of the amount of bright sunshine is received from 146 stations in the British Isles. Of these some are First or Second Order Stations, whilst from others the sunshine record is alone received.



Such is the official machinery for the scientific study of the weather in the British Isles. It should be mentioned that the Meteorological Office, situated at 63, Victoria Street, Westminster, London, S.W., is under the management of the Meteorological Committee. The Committee, which was constituted by Minute of the Lords Commissioners of His Majesty's Treasury, dated May 20, 1905, consists of seven members, Mr. W. Napier Shaw, LL.D., Sc.D., F.R.S., the Director of the Meteorological Office, London, being the chairman. The Committee administers an annual parliamentary grant for meteorological purposes. It was £15,500 in each of the financial years 1907, 1908, and 1909. The Marine Superintendent of the Meteorological Office is Mr. M. W. Campbell Hepworth, C.B., Commander, R.N.R.; the Superintendent of the Statistics and Library Branch is Mr. R. G. K. Lempfert, M.A. Cantab.; the Superintendent of Instruments is Mr. R. H. Curtis; and the Chief Clerk and Cashier is Mr. John A. Curtis. The telegraphic address of the Office is "Weather, London."

Besides the Meteorological Office, the Royal Meteorological Society and the Scottish Meteorological Society have covered the United Kingdom with a network of climatological and phenological stations.<sup>1</sup> Each of these societies also publishes a journal containing many valuable papers on meteorological subjects. Mention should also be made in this connection of the wonderful system of rainfall observation which the late George J. Symons, F.R.S., organised through years of patient and untiring labour, and which is still carried on with ever-increasing success by Hugh Robert Mill, LL.D., D.Sc., Ex-President of the Royal Meteorological Society. In 1908 the number of perfect rainfall returns published in *British Rainfall* amounted to 4,538—3,326 in England, 364 in Wales, 604 in Scotland, and 244 in Ireland. England had about one observer for each 17 square miles, Scotland about one for each 50 square miles, and Ireland only about one for each 140 square miles.

As a type of what a fully equipped meteorological observatory should be, the Fernley Observatory, Southport, may be adduced.

<sup>1</sup> Phenological stations are those at which a registry is kept of natural periodic phenomena connected with the animal and vegetable kingdoms.

It includes three stations, of which the principal is situated in Hesketh Park, Southport (lat.  $53^{\circ} 39' 24''$  N. ; long.  $2^{\circ} 59' 3''$  W.). The Marshside Anemograph Station is situate on the coast, over a mile N.N.E. of the Hesketh Park Observatory (lat.  $53^{\circ} 40' 18''$  N.; long.  $2^{\circ} 58' 23''$  W.). The Barton Moss Evaporation Station lies 3 miles inland, about  $5\frac{1}{2}$  miles S.S.W. of the Hesketh Park Observatory (lat.  $53^{\circ} 34' 37''$  N. ; long.  $3^{\circ} 1' 12''$  W.). Besides these stations there is the Hesketh Park Astronomical Educational Observatory (lat.  $53^{\circ} 39' 25''$  N. ; long.  $2^{\circ} 59' 8''$  W.). All these observatories are under the superintendence of Mr. Joseph Baxendell, F.R.Met.Soc., Meteorologist to the Southport Corporation, who publishes an annual report replete with information.

In relation to the study of the meteorology of the British Isles allusion should be made to two periodical publications of the Meteorological Office apart from the *Daily Weather Report*. These are — (1) the *Weekly Weather Report*; (2) the *Monthly Weather Report*, issued as a supplement to the same.

The *Weekly Weather Report* has appeared since the beginning of February, 1878. It is published regularly on Thursdays, and gives a summary of the weather of the week ending with the previous Saturday, intended principally for agricultural and sanitary purposes. A division of the British Islands into twelve districts, which are identical with the forecast districts of the *Daily Weather Report*, is adopted. The districts are further grouped into extreme north, eastern, and western districts, and extreme south (islands in the English Channel). In its present form the *Report* contains :

1. General remarks on the meteorological conditions of the week, with a table describing in words the divergence of the warmth, rainfall, and sunshine experienced in each district from the average for the district for the time of the year ; the dates of occurrence of the highest and lowest temperature of the week, for each station.

2. A table summarising in numerical form the conditions of temperature, rainfall, and sunshine for each district for the week, the current season, and the calendar year.

3. A table containing the data from stations from which the values for districts are calculated.

4. A table containing information for selected stations concerning the minimum temperature on the grass and the temperature in the ground.

5. A table giving information of the temperature of the seawater at a selection of stations on the coast of the British Isles.

6. A series of maps or Synoptic Charts, showing the distribution of pressure and wind over Europe and Iceland at 7 a.m. and 6 p.m. on each day, and the temperature, weather, and sea disturbances at 7 a.m. each day. The maps for each day are accompanied by a brief account of the distribution of weather for that day and the changes which have taken place.

7. A table giving the results of observations of the upper air taken by means of kites and balloons. These results include particulars as to temperature, humidity, and wind (direction and force) at various levels.

For the maps and descriptive account the daily telegraphic reports are used, and are supplemented by the information contained in the *Bulletin International*, published in Paris, reproducing meteorological telegrams from the whole of Europe, so that the area represented is much larger than that covered by the *Daily Weather Report*.

For the statistical summaries the information from the telegraphic reporting stations in the British Isles is supplemented by returns of daily observations supplied by volunteer observers from about 110 other stations. Of these twenty-seven supply only the daily amounts of bright sunshine. The Reports contain also tables of "Accumulated Temperature." These are designed to give persons engaged in agriculture a better means of estimating the manner in which vegetation is affected by temperature than those afforded by the more usual methods of treating the readings of the thermometer. The tables show for each week, and for the whole period from the beginning of the year, the weekly and progressive values respectively of the combined amount and duration of the excess or defect of the air temperature, above or below a suitably fixed standard, or *base temperature*. The base temperature adopted is 42° F., as being nearly equivalent to 6° C., which has been considered by Continental writers on these subjects to be the critical value, the temperature above

which is mainly effectual in starting and maintaining the growth, and in completing the ripening of agricultural crops in a European climate. This base is also convenient as being precisely  $10^{\circ}$  F. above the freezing-point of water, or the melting-point of ice.

Accumulated Temperature is expressed in Day Degrees—a day degree signifying  $1^{\circ}$  F. of excess or defect of temperature above or below  $42^{\circ}$  F. continued for twenty-four hours, or any other number of degrees for an inversely proportional number of hours. It has been ascertained, by calculation from a considerable series of hourly observations at various places, that the accumulated temperature may be computed, with a very close approximation to the truth, from the observed difference of the mean of the daily maximum and minimum temperatures from the base alone.

The *Monthly Weather Report* for 1908 gives a complete résumé of the observations dealt with each month at the Meteorological Office. Each monthly issue contained :

1. General remarks on the weather over the British Islands.

2. Summaries, in international form, of observations made at normal climatological stations at 9 a.m. and 9 p.m., and at telegraphic reporting stations at 7 a.m., 1 p.m., and 9 p.m., or 7 a.m. and 6 p.m., as the case may be. The international form has been extended to include information regarding the duration of bright sunshine, the earth temperatures at 1 foot and 4 feet (from 1906), the number of observations of fresh or strong winds (forces 4 to 7 of the Beaufort Scale, from 1906), the number of days of fog (from 1906), and of ground frost (minimum temperatures on the grass,  $30^{\circ}$  and below, from 1908). Summaries for districts, based on observations at the stations of the *Weekly Weather Report*, have been given for the elements dealt with in that *Report*.

3. Abridged summaries of extremes of temperature, rainfall, sunshine, earth temperatures, and grass minimum temperatures for auxiliary climatological stations.

4. A plate of four maps, showing—

(1) The monthly distribution of pressure and winds based on the morning observations at telegraphic reporting stations; also the average distribution of pressure for the month for the period 1871-1905.

(2) The movements of depressions.



- (3) The distribution of mean temperature over the land and in the coastal waters.
- (4) The distribution of bright sunshine. This map was added for the first time in the issue for 1908.

5. A full-page map, showing, by means of isohyetal lines, the distribution of the month's precipitation.

These maps have been prepared by Dr. H. R. Mill, the Director of the British Rainfall Organisation, and are based on data from nearly 1,000 stations.

Monthly summaries for a number of additional stations will be found in the *Meteorological Record*, issued by the Royal Meteorological Society, or in the *Journal of the Scottish Meteorological Society*.

The summaries given in the latter are also printed in the Quarterly Reports of the Registrar-General for Scotland. The meteorological data in the Quarterly Reports of the Registrars-General for England and Wales and for Ireland are abstracted from the *Monthly Weather Report*. Additional information as to rainfall may be found in the annual volumes of *British Rainfall*.

The various serial publications of the Meteorological Office are now grouped together under the general title *The British Meteorological Year-Book*. For the year 1908 the parts of the Year-Book are as follow :

Part 1.—The *Weekly Weather Report*, with three appendices and a special supplement. It is issued on Thursday of each week.

Part 2.—The *Monthly Weather Report*, with an annual summary. It is issued on the 27th of each month as a supplement to the *Weekly Weather Report*.

Part 3.—Daily Observations at Stations of the Second Order and at Anemograph Stations. These observations, which are exclusive of those included in the *Daily Weather Report* described above, are issued in monthly parts, within about six *weeks* of the close of each *month*.

Part 4.—Hourly readings at the four Observatories in connection with the Meteorological Office—namely, Kew, Falmouth, Aberdeen, and Valentia. These readings are issued in monthly



sections for each Observatory within about six *weeks* of the close of each *month*.

To return to the *Daily Weather Report*, it may interest the reader to learn something about the composition of the weather telegrams which are sent at 7 a.m. by West European time daily to the Meteorological Office, London. The telegraphic reports, which are addressed simply to "WEATHER, LONDON," consist of two parts.

The first part is composed entirely of figures, arranged in groups of five each, in accordance with the Code approved by the International Meteorological Congress, held at Utrecht in September, 1874. The second part consists mainly of words, occasionally mingled with figures in groups, and is designed to throw additional light on the information given in the first part of the message.

The following numerical scales are used in drawing up the telegrams :

*Wind Direction.*—The thirty-two different points of the compass are supposed to be numbered, beginning with 01 = N. by E. and 02 = N.N.E. (*true bearings*), to 08 corresponding to E., 16 to S., 24 to W., and 32 to N. According to this scale, S.S.E. would be telegraphed "14," and W. by N. "25." At the Vienna meeting of the International Meteorological Committee (1873) it was agreed that only sixteen directions should be given in the wind-rose, or table showing the direction of the wind according to the points of the compass. In the case of intermediate directions being observed, it was proposed to count them alternately to the one side or the other.

*Wind Force.*—This is estimated in accordance with the annexed scale, commonly known as the "Beaufort Scale," because it was originally drawn up by Admiral Sir F. Beaufort, in command of H.M.S. *Woolwich* in 1805. The wording has been altered so as to suit the present use of double topsails. The values which were in use for official purposes at the Meteorological Office in 1874 have been superseded by those given in the column of the table opposite, headed "Miles per Hour (1909)" :

It has recently been decided that for statistical purposes in publications of the Meteorological Office winds of force less than 8 shall not be counted as gales, and to avoid ambiguity

TABLE I.—BEAUFORT SCALE OF WIND FORCE.

			Mean Wind Force in lbs. at standard density. P = 0.105 B <sup>3</sup> .	Equivalent Hourly Velocity for expressing Estimates in miles per hour, and <i>vice versa</i> . (V = 1.87 √ B <sup>3</sup> .)	Miles per hour (1909).	
0	Calm ..	..	0	0	0	
1	Light air ..	..	0.01	0	1 to 3	
2	Slight breeze ..	..	0.08	5	4 ,, 7	
3	Gentle breeze ..	..	0.28	10	8 ,, 12	
4	Moderate breeze	That to which she could just carry in chase, "full and by" .. That which she could scarcely bear with close-reefed main topsail and reefed foresail .. That which would reduce her to storm staysails .. That which no canvas could withstand ..	0.67	15	13 ,, 18	
5	Fresh breeze ..		..	1.31	21	19 ,, 24
6	Strong breeze ..		..	2.30	27	25 ,, 31
7	Moderate gale (High Wind)	..	3.60	35	32 ,, 38	
8	Fresh gale (Gale)	..	5.40	42	39 ,, 46	
9	Strong gale ..	..	7.70	50	47 ,, 54	
10	Whole gale ..	..	10.50	59	55 ,, 63	
11	Storm ..	..	14.00	68	64 ,, 75	
12	Hurricane ..	..	above 17.00	above 75	above 75	

.. ..  
 Just sufficient to give steerage way ..  
 That in which a well-conditioned man-of-war, with all sail set, and "clean full," would go in smooth water from ..  
 3 to 4 knots ..  
 5 to 6 knots ..  
 Royals, etc. ..  
 Single-reefed top-sails, or topgallant sails ..  
 Double-reefed top-sails, jib, etc. ..  
 Triple reefed top-sails and courses ..  
 Close-reefed topsails and courses ..  
 That which she could scarcely bear with close-reefed main topsail and reefed foresail ..  
 That which would reduce her to storm staysails ..  
 That which no canvas could withstand ..

implied by the use of the term "moderate gale" for force 7, the Beaufort description has been modified for use in connection with the Daily Weather Service by the description in italics given in the table for forces 7 and 8—namely, "*High Wind*" and "*Gale*" respectively.

As storms in the British Islands are rarely, if ever, so violent as those in tropical latitudes, great caution should be used in the insertion of extreme figures in the telegraphic reports, such as 12 for the wind and 9 for the sea.

A careful comparison of the Beaufort estimates with the wind velocities recorded simultaneously by anemometers belonging to the Meteorological Office has shown that the most probable equivalent hourly velocity for expressing individual estimates in miles per hour, or *vice versa*, agrees very closely with the results calculated by the formula—

$$V = 1.87 \sqrt{B^3},$$

where  $V$  is the wind velocity expressed in miles per hour and  $B$  the Beaufort number.

The relation between the wind-pressure and the Beaufort numbers is given by the corresponding formula—

$$P = 0.0105B^3,$$

where  $P$  is the pressure in pounds per square foot.

The velocity and pressure equivalents calculated from these two formulæ have been included in Table I.

A less detailed statement of the relation between the Beaufort numbers and the corresponding hourly velocity of the wind is given in the following table :

TABLE II.—RELATION BETWEEN BEAUFORT SCALE AND HOURLY WIND VELOCITY.

Beaufort Scale Number.	Corresponding Wind.	Limits of Hourly Velocity in Miles per Hour.
0	Calm	Under 1
1 to 3	Light breeze	1 to 12
4 ,, 5	Moderate wind	13 ,, 24
6 ,, 7	Strong Wind	25 ,, 38
8 ,, 9	Gale	39 ,, 54
10 ,, 11	Storm	55 ,, 75
12	Hurricane	Above 75

TABLE III.—SCALE OF SEA DISTURBANCE AND WEATHER.

<i>Sea Disturbance.</i>		
0=Dead calm. 1=Very smooth. 2=Smooth. 3=Slight.	4=Moderate. 5=Rather rough. 6=Rough.	7=High. 8=Very high. 9=Tremendous.

<i>Weather.</i>	
0=Sky quite clear. 1=Sky a quarter clouded. 2=Sky half clouded. 3=Sky three-quarters clouded. 4=Sky entirely overcast.	5=Rain falling. 6=Snow falling. 7=Haze. 8=Fog. 9=Thunderstorm.

Any other phenomena must be reported in words after the groups of figures, such as “lightning last evening,” “heavy dew,” “aurora.” In this scale the values 0 to 4 refer to the *amount* of cloud, not to its *density*.

*Time.*—00 or 24 stands for midnight ; 01 for 1 a.m., and so on every hour to 11 p.m., which is represented by 23.

Armed with the foregoing scales, the observer, having taken the readings at 7 a.m. (Greenwich time), transmits a telegraphic message to “Weather, London,” consisting of six groups of five figures each. Here is an example :

97622      09549      96228      06253      50046      64485

The first group contains the reading of the barometer (omitting the first figure of the value), reduced to 32° F. and the mean sea-level, for 6 p.m. on the previous day, and the direction of the wind (*true*, not magnetic) at the same hour. 97622 is thus resolved into : Barometer, 29·76 inches ; wind, W.S.W.

The second group gives the force of the wind at 6 p.m. on the previous day, the weather and air temperature at the same hour. 09549 thus becomes : Wind force, 9, or a strong gale ; weather, rainy ; air temperature, 49°.

The third group supplies the reading of the barometer at 7 a.m., reduced to 32° F. at mean sea-level, and also the direction of the wind. Thus 96228 becomes : Barometer, 29·62 inches ; wind, N.W.

The fourth group gives the wind force, weather, and air temperature at 7 a.m., for 06253 = wind force, 6, or a strong breeze ; 2, half-clouded sky ; dry-bulb thermometer, 53°.



The fifth group contains the reading of the wet-bulb thermometer at 7 a.m., and the amount of precipitation or rainfall, including melted snow and hail, during the last twenty-four hours, in inches, tenths, and hundredths, omitting the decimal point. For example: 50046 = wet-bulb temperature, 50°; rainfall = 0.46 inch.

The sixth group gives the maximum and minimum temperatures in the last twenty-four hours, together with the amount of sea disturbance at 7 a.m. At inland stations the last figure is of course always 0. Thus, 64485 means that the maximum temperature in the twenty-four hours ending 7 a.m. has been 64°, the minimum temperature has been 48°, and the sea is "rather rough" at 7 a.m. (*i.e.*, sea disturbance, 5).

By the adoption of this code system, a very full report can be condensed into what is equivalent to only six words—for, under the Post-Office Regulations, five figures, or a letter preceding or following a group of figures, are counted as only one word, and charged for accordingly. The foregoing information has been culled from the official instructions for meteorological telegraphy, prepared for the use of observers exclusively, in accordance with the International Code adopted at Utrecht in September, 1874.

The meteorological conditions which possess the greatest interest and value for Medical Officers of Health, from their influence on the prevalence of disease and on the death-rate, are, undoubtedly, *temperature*, *humidity*, and *rainfall*. But as these depend to a large extent on the state of the barometer, the direction and force of the wind, and the condition of the sky as regards cloud, fog, and mist or haze, it is necessary to study the whole group of meteorological phenomena. In subsequent chapters, then, a detailed description of the various instruments required by the observer will be given, and the practical application of the information afforded by them will be explained.

The instruments required for a Second Order Station or Normal Climatological Station are a standard mercurial barometer reading to .002 inch, maximum and minimum thermometers, dry and wet bulb thermometers, and a rain-gauge. The barometer and thermometers must have "Kew" certificates from the National Physical Laboratory. All the four thermometers



named should be suspended in a properly placed Stevenson thermometer screen (see p. 89). These instruments—barometer, four thermometers, and rain-gauge—are indispensable, but besides them it is desirable to have also a black-bulb maximum thermometer *in vacuo*, a bright-bulb maximum thermometer *in vacuo*, and a minimum thermometer (graduated on the stem, without attached scale) for terrestrial radiation, one or more earth thermometers, an anemometer (if the exposure is sufficient), and a sunshine recorder.

All the thermometers should be graduated on the stem, and only such instruments should be used as have been verified at Kew Observatory, so that the "index-error" may be known. The height of the cistern of the barometer above mean sea-level must be accurately known, since a difference of level of 1 foot gives rise to a difference in the reading of the barometer of very nearly  $\cdot 001$  inch.

The distance of outdoor instruments from any object such as buildings or trees should be twice the height of the object. A suitable site in an open space 300 feet square would afford a quite satisfactory urban exposure. Roofs are not appropriate sites for meteorological observations. The rain-gauge should stand in a grass plot with its rim 1 foot above the grass-level. The sunshine recorders in use at official stations are of the Campbell-Stokes pattern.

## CHAPTER V

### HISTORY, ORGANISATION, AND WORK OF THE UNITED STATES WEATHER BUREAU

THE development of interest in meteorology in the United States dates from the earliest times of its history. It was apparently Benjamin Franklin who first called attention to the progression of weather from west to east. He noted that a north-easterly storm appeared earlier at Philadelphia than at Boston.

Thomas Jefferson, afterwards President of the United States, was the first to undertake in that country simultaneous meteorological observations. From 1772 to 1777 he carried on such observations at Monticello with Mr. (afterwards Bishop) Madison, who lived at Williamsburg, both places being in Virginia, and about 120 miles apart.

With the invention of the telegraph by Morse, in 1837, came the idea of collecting at one place simultaneous observations from different parts of the States; and on this followed, in about ten years, the idea of charting these instantaneous observations, and deducing from this chart some conclusions as to the future weather. Commodore Maury strongly advocated this plan, and in the early "fifties" it was put into operation by Professor Henry, and continued until the breaking out of the Civil War, when it was discontinued. In 1869 Professor Cleveland Abbe, then Director of the Cincinnati Observatory, undertook the collection of data and the forecasting of the weather for the Cincinnati Board of Trade. The data were collected free of cost by the Western Union Telegraph Company, and the map employed by Professor Abbe was made up in the local office of that company by the manager at Cincinnati.

In the meantime very great interest was being taken in the

same direction by Professor I. A. Lapham, of Milwaukee, Wisconsin, and it was perhaps Professor Lapham who personally interested a prominent member of Congress from Wisconsin, the Hon. H. E. Paine, in the matter, and he finally introduced into Congress the Bill which, on becoming law, created the Weather Service of the United States. In the session of February 9 to April 20, 1870, a joint resolution was passed by Congress, which required the Secretary of War to take meteorological observations at the military stations in the interior of the continent, and at other points in the States and territories of the United States, and to give notice on the northern lakes and on the sea-coast, by magnetic telegraph and marine signals, of the approach and force of storms. At the same session an appropriation of \$15,000 was made to carry into effect the foregoing resolution. This work was placed by the Secretary of War in the hands of the Chief Signal-Officer, as it involved questions of signalling, and had been recommended by him. At that time General Myer was Chief Signal-Officer, and it was very fortunate for the meteorological service of the States that it was first placed in such energetic hands.

Annual appropriations were made thereafter for the service, and in terms enlarging its scope, until it was transferred, in 1891, to the Department of Agriculture as the Weather Bureau.

The first weather bulletin of the new service was issued November 1, 1870, and the first storm warning a week later. The first weather map appeared on January 1, 1871. This was not the earliest weather map published, for others had been issued previously under the direction of Professor Abbe, and even before that weather maps had been started elsewhere. In 1861 Admiral FitzRoy inaugurated the British system of weather charts and forecasts. On September 16, 1863, Leverrier, in Paris, began the publication of a French series of weather maps, which have continued without interruption from that day to this. The American series was the third of those which are now issued daily in various parts of the world.

On October 1, 1890, a Bill was finally passed which provided that "the civilian duties now performed by the signal corps of the army shall hereafter devolve upon a bureau, to be known as the Weather Bureau, which, on and after July 1, 1891, shall be

established in and attached to the Department of Agriculture." In accordance with law the service was so transferred, and Mr. Mark W. Harrington, then Professor of Astronomy and Director of the Observatory at the University of Michigan, and founder and editor of the *American Meteorological Journal*, was placed in charge.

By the terms of the transfer the Chief of the Weather Bureau, under the direction of the Secretary of Agriculture, had charge of the forecasting of weather, the issue of storm warnings, the display of weather and flood signals for the benefit of agriculture, commerce, and navigation, the gauging and reporting of rivers, the maintenance and working of sea-coast telegraph lines, and the collection and transmission of marine intelligence for the benefit of commerce and navigation, the reporting of temperature and rainfall conditions for the cotton interests, the display of frost and cold-wave signals, the distribution of meteorological information in the interests of agriculture and commerce, and the taking of such meteorological observations as may be necessary to establish and record the climatic conditions of the United States, or as are essential for the proper execution of the foregoing duties.

The first Appropriation Bill set aside a considerable sum for the distribution of forecasts to farmers. For this reason, and because of the transfer of the Bureau to the Department of Agriculture, especial attention has been given since the transfer to the more extensive and complete distribution of the forecasts to country communities, and especially to farmers.

Among the most important dates in the history of the meteorological service of the United States are the following :

1871, November 13.—First exchange of observations with Canada. This continues to the present, and is very helpful in the forecast work of the Bureau.

1872, January.—As authorised by the Appropriation Bill for that fiscal year, the service arranged for reports of the stages of rivers, and in the following spring these were utilised in forecasts of floods.

1872, September 3.—First balloon ascent of the Signal Service for meteorological purposes. The ascent was made by Samuel A.



King, aeronaut, and George C. Schaeffer, jun., as meteorological observer.

1873.—In the autumn of this year the report of observations from the West Indies began.

1875, July 1.—On this date began the publication of the bulletins and charts of international meteorological observations. The first was for the date of January 1, 1875. The series was discontinued at the end of 1887, but the monthly and annual summaries were continued to 1889.

1876.—Stations were established at St. Michael's and St. Paul's in Alaska.

1881-1884.—The international polar explorations were begun by the United States in 1881. The Lady Franklin Bay party returned in 1884.

1881, April 11.—The movement for the assistance of State weather services was initiated by a letter of this date.

1887.—In May the first weather crop bulletin was published.

1887.—The marine meteorological service was surrendered to the Hydrographic Office of the Navy.

1888.—A beginning was made in the installation of automatic barographs and thermographs at stations, thus enabling hourly readings to be made of the principal meteorological elements.

1889.—The publication of the *Bibliography of Meteorology* was begun by the appearance of the first part in this year.

1891, July.—The system of Local Forecast Officials was first put in operation.

1892, Spring.—The special investigation of the Great Lakes was begun.

1892, Summer.—The first systematic study of thunderstorms by the meteorological service.

1892, August.—The first meeting of the Association of State Weather Services.

1893.—Continuous practice work by all forecasters was introduced; the competitive idea for filling professorships with accomplished forecasters was adopted; the Flood Section was re-organised, and local predictions were placed in the hands of local forecast officials; the first current chart of the Great Lakes was



issued ; the first annual volume in the form fulfilling the international requirements was published.

The various bureaux in Washington City are, with one or two exceptions, directly under a member of the Cabinet. The Weather Bureau is under the Secretary of Agriculture. As in the other bureaux, under their proper Secretaries, he can dictate the policy of the Bureau, and can appoint or dismiss any or all employees, with the exception of the Chief of the Bureau, who is appointed by the President and confirmed by the Senate ; and even in this case the wishes of the Secretary would always receive favourable consideration. While the officers of the Bureau may be changed at the will of the Secretary, as a matter of fact such change is infrequent, except in the force of messengers and labourers. The chief officers of the Bureau are continued with little reference to changes of administration, and in the technical observing force such change is practically unknown.

The appropriations for the Bureau are made annually by Congress, and are a part of the appropriations for the Department of Agriculture. An estimate is carefully made by the officers of the Bureau some months before the session of Congress in which the appropriation must be made, and about a year before the appropriation can become available. This estimate is submitted to the Secretary of Agriculture, and after receiving his approval, passes to the Committee on Appropriations of the House of Representatives. On receiving their approval it is submitted to Congress.

Among the various divisions of the central office at Washington stands foremost the Forecast Division. It has charge of forecasts, of floods, of the telegraphic section, of storm signals, and of the practice which is continuously performed by the forecasters. The forecasts are made twice a day, immediately on receipt of the telegraphic reports of observations from the regular telegraphic stations. As soon as the forecasts are made, the maps are printed in the Bureau office, and the forecasts are given to the Associated and United Press Companies, by which they are distributed over the United States. Each forecast contains statements concerning the weather for divisions of the United States, each division being usually a State, or a large part of the State. The forecast officials

on duty at Washington are kept in constant practice. They generally have the rank of professor. Besides this practice, which occupies a fractional part of the day, each professor is entrusted with other and important duties. One has charge of the instrument-room and of all duties relating to instruments. Another has charge of the *Monthly Weather Review*, which he edits, and also of a great variety of duties relating to theoretical and scientific meteorology. Another has charge of the collection of statistics concerning tornadoes and other destructive storms. And the fourth is entrusted with the special investigation of the relation of meteorology to magnetism. The telegraph section under this division has a force of operators who receive and send telegrams, and have charge of the various coast telegraph lines belonging to the Weather Bureau.

The State Weather Service Division is in charge of the weather-crop work, the thunderstorm work, the distribution of temperature and weather signals, and the snow charts of the Bureau. In general its work is essentially climatological. It is the centre of the State Weather Services scattered over the United States. It receives weekly during the crop season the weather-crop reports from the State centres, and digests them into the *Weather-Crop Bulletin*, which is immediately sent to press, and appears ready for distribution the day the reports are received. It prepares and sends to the State centres, for distribution from those points, the signals for temperature and weather, which are intended in general for the agricultural communities; and in a manner similar to the weather-crop bulletins, during the winter season it collects the data for snow-charts, and has the charts printed and distributed the day the data are collected. It is also in charge of the special thunderstorm work, this work being done through the machinery of the State Weather Services.

The Records Division is entrusted with the care of the records, with the compilation of data of all sorts required for the work of the Bureau or by the general public, and with the publication of reports, more especially the annual reports made for general information. The accumulation of records in charge of this division has, after very many years of work, become extremely great, and includes not only the records of the meteorological

service which finally ended in the Weather Bureau, but also of that meteorological service which was carried on previously by the Smithsonian Institution, and that also by the Surgeon-General, which to some extent preceded that of the Smithsonian. These records are kept in a fireproof vault in such form as to be readily accessible. Other private records have been added to these, either by purchase or gift, until the collection forms by far the most complete record of climatological interest to be found in the United States—so complete, in fact, that its use is entirely indispensable to anyone who wishes to make a competent study of any feature of the weather or climate of the States. In the compilation of data for the general public a great deal of time is spent by the Records Division. All sorts of questions relating to all sorts of features of the weather and climate come constantly to the Bureau. The replies must be made with very great care, so as to be thoroughly authentic. No less important is its duty in checking observations and in detection of errors. The system is so complete that the errors are charged up against the individual observers, and at regular times a statement is issued giving the names of the observers who have been the most free from errors in the preceding interval.

To the Instrument Section is entrusted the question of purchase and shipment of instruments, their testing when received, their condition at stations, their repairs when needed, and the examination of the automatic records as they are received from the various stations. It is also occupied with devising new forms of instruments and new methods of taking observations, and performs a large amount of work in physics, more or less directly connected with this purpose.

The Publications Division is in charge of the publishing and mailing of the material of the Weather Bureau. Those matters which are urgent are published in the Bureau office. In addition to that there are a few other publications made by the Bureau office which are not urgent, but are used to fill up the intervals of time on the part of the compositors and pressmen. Most of the other matter issued by the Bureau is published by the Government Printing Office at a fixed price, the same being deducted from the appropriation for the Bureau. In a few special cases

the publications of the Bureau are made by joint-resolution of Congress, in which case there is no charge against the Appropriations of the Bureau. The publications prepared in the Bureau office are the maps of all sorts, the reports requiring immediate distribution, and special publications of the same sort. Among the other publications—not matters of so much urgency, but actually published in the Bureau—are many of the innumerable “forms” used in the collection and distribution of data, the *Monthly Weather Review*, which is prepared and printed entirely within the chief office at Washington; and some of the series of printed bulletins in octavo form issued by the Bureau. Also, lithographed maps and charts, though not urgent, are usually printed by the Bureau. This division has in its charge a draughting-room, in which maps are prepared for printing and other necessary drawings are made; and the composing-room, in which a considerable number of printers are employed. In this division labour is saved in all possible ways, the most notable one, perhaps, being that of the use of a long series of logographs. In the publication of weather tables and forms the same combination of letters and figures frequently recurs, and in this case a single type has been cast to include these letters and figures. In this division is also included the press-room. A large part of the work of the Bureau is lithographed, because the lithograph makes the cheapest, easiest, and readiest means of publishing urgent data in cartographic form. As a result a force of lithographers is kept in connection with the press-room. Also connected with the division are the folding and stitching room and the mailing-room. The mailing lists are kept with care, in order to economise the publications of the Bureau.

Connected with the general office at Washington is also a library, containing a number of books and pamphlets, so arranged as to show its annual growth. The library also contains many meteorological and some geographical charts.

These books are obtained in considerable part by exchange with other Meteorological Services and with various Governments, in part also by gift, but in large part by actual purchase. The result is a technical and special library of unusual size and value. So large and complete is it that with the aid of correspondents



from all over the world the librarian has undertaken to publish a bibliography of meteorology.

In 1884 the Signal Office began the compilation from the printed literature comprising the books, pamphlets, memoirs, and papers in serial publications of all kinds, relating to meteorology and its applications. In 1887 the number of titles collected and classified was about 50,000.

In addition to these various sections of the Bureau, there is a large mass of correspondence to be cared for. This comes under the direct cognisance of the Chief Clerk, who has a small force of clerks under him to perform this work. The letters received are assigned to the various divisions or individuals most competent to answer them. The replies are drawn up by these divisions or individuals, with the aid of stenographers, and sent to the Chief Clerk for supervision or signature before being mailed. Correspondence, manuscripts, and other papers of importance are passed over to a special official called the File Clerk, who has entire charge of the files of the Bureau, and whose duty it is to speedily find any paper of any date required by any officer, and to return it to its place when it comes back to him.

Especial attention is also paid to comments and criticisms of the Bureau from whatever source they come, and to this duty part of the time of one clerk is devoted. The observers at stations are instructed to send to the central office all comments on the Bureau, and especially criticisms of it. This serves the double purpose of keeping the Bureau in close touch with the popular wants, and of informing the central office of the way in which these wants are filled at the stations. These matters are kept filed in such a way as to be ready for reference.

What precedes relates only to the central office in Washington City. There is also a large number of employés scattered at numerous stations over the entire United States. These stations are: Regular telegraphic stations, stations in the West Indies (excluding stations in Canada, with which only an exchange is carried on, these stations being controlled by the Canadian Service), river and flood reporting stations, voluntary stations, mountain stations, telegraph-line repair stations, storm-signal stations, temperature and weather stations, and stations in the



cotton, rice, and sugar regions ; also stations for special reports of thunderstorms and others.

The River and Flood Section, under the Forecast Division, has especial charge of the river gauges, which are scattered at frequent intervals up and down the principal rivers, from which reports are received at regular intervals. The duty of the River and Flood Section is the forecasting of the conditions of the rivers, more especially during the period of flood. This work has heretofore been entirely done in the central office at Washington, and was in the hands of one officer, who was alone entitled to make forecasts concerning the state of the rivers. It has been found, however, that it is impracticable for a single officer to obtain the intimate familiarity with, and keep in mind the current knowledge of, all the details that are necessary for safe forecasting the entire length of important rivers. There are so many local conditions—the width of the river, opportunity for set-back—so many conditions that may happen accidentally, as when a levee breaks, or when at a certain height the river may pour over the banks into an empty space at one side—that it has been found necessary to divide up the work among a considerable number of men, who are stationed in the vicinity of the places where the forecasts are to be made. These men become familiar with the details mentioned above, and hence can perform the work more satisfactorily. This policy has been introduced since the season of the floods of 1893. It is confidently expected that its success will in time be much more considerable than has been experienced heretofore.

The cotton, rice, sugar, and other special services are intended for the protection of specific crops grown in limited areas. Special reporters are scattered through these regions, who report with special reference to the climatological needs of these individual crops. For the cotton interest this service has been found to be quite successful. There has not been so good an opportunity to test it for the rice and sugar interests.

#### *Forecasts.*

The main duty of the Weather Bureau is the forecast of the weather, and special attention is paid, therefore, to this part of

the work. The other features of the work of the Weather Bureau are incidental to this.

At the hour of eight o'clock, 75th Meridian Time, the observers of the Weather Bureau all over the United States, at each telegraphic station, proceed to take their observations. These observations are taken, so far as possible, in exactly the same way at each station, with similar instruments, and with exactly the same precautions against error and corresponding provisions for their correction. As soon as these observations are taken—a proceeding which usually occupies the observer but a few moments—they are at once reduced to the form of a telegram and expressed in the words of the telegraphic "code" employed by the Bureau. They are then promptly taken to the telegraph office, and at once sent on to the Bureau. For a few moments after eight o'clock, morning and evening, all over the United States, all other telegraphic business gives way to the business of the Weather Bureau. The telegrams are at once forwarded, in order to reach the central office in Washington at the earliest possible moment. They are forwarded, however, in such a way that they can be dropped on their passage at other stations where they are needed. That is to say, they are collected in "circuits," and the telegram for each station in the circuit is dropped at each of the stations where it may be of use. The result is, that the central office at Washington is furnished with the observations from all over the United States, and the individual stations wishing to have them are furnished with the observations which they need. They come into the central office at Washington in circuits one after the other—the Southern circuit, the New England circuit, and so on. They are received in the Bureau office, about an hour after they are taken, by operators employed for the purpose, and are at once taken off on the typewriter, and sent by messenger to the forecast-room. On reaching the forecast-room, they are passed to an official, called a translator, whose duty it is to read in ordinary language the telegram expressed in the code, so that the clerks who surround him, and the forecast official, can obtain the information as rapidly as possible. Of these translators there are several in the office, and at each of the outside stations, where a considerable number of the reports are used, one man at least must be expert in the code.

This takes us to the forecast-room, which is a very busy place for about two hours after nine o'clock in the morning and nine o'clock in the evening, 75th Meridian Time. This room has a body of clerks to take down the data on individual maps. At the same time a small force of printers proceed to set up the tables used on the maps, doing this directly from the reading of the translator. One of these is occupied with setting up the symbols for wind direction and weather, as they will appear eventually on the finished map. As rapidly as the translator reads the telegrams the data are placed on maps, of which there are four, the principal map (which is the proper weather map used in the regular forecasts) and three auxiliary maps made by the clerks as the observations come in, and used by the forecast official to aid him in making the official forecast. The map proper, or weather map, which is afterwards published, is made by the forecast official himself, or under his immediate supervision. As soon as these maps are finished—and that is almost immediately after the reading of the last telegram received—the forecaster proceeds at once to dictate his forecasts to a stenographer beside him. These are made for separate States, or for halves or quarters of larger States, and must be made in a certain fixed order, in which order they are always printed. As they are taken by the stenographer, the compositors set them up, and almost as soon as they are finished by the forecast official they are in print, and the proof copy is taken off. This is read by the forecaster before he leaves the room. After making the forecasts he also decides to what points special signals shall be sent indicating high winds or storms, and gives orders to this effect.

The principal map, being finished in this way as a manuscript, is taken at once to the lithographer, transferred to stone, placed on the press by pressmen who are waiting to receive it, and run off with all possible celerity. Messengers stand in waiting, so that the first few copies are taken in hand, carried to the trains, or to the points where they are to be left, by means of bicycles or otherwise, so that with all possible despatch the maps are distributed as soon as they are printed. In the meantime the agents of the great news-collecting agencies are at hand to receive

the forecasts, which they distribute by telegraph to various parts of the United States. The time which elapses from the taking of the observations until the map is finally ready for the messengers varies from two and a half to three hours, depending upon circumstances. It is rare for it to reach three hours. The usual time is two hours and thirty-five minutes to two hours and forty-five minutes.

The forecasts were formerly made for the day or the night on which the observations were received. This being the case, notwithstanding the speed that was used in getting them before the public, the period for which they were intended was partly passed before the forecasts could reach their readers. This has now been changed, so that the forecasts that are made from the morning observations, as well as those from the evening observations, are intended for the next day. This amounts to making forecasts for thirty-six hours ahead, instead of twenty-four, and even twelve, as was formerly the case. This has been found to be much more satisfactory to the public, and as a result forecasts can appear in the evening papers which are intended for the next day, so that those interested in the weather of that day can have abundant time to make their preparations.

After the forecasts have been made comes the question of verification. This is done systematically, both for the official forecaster in Washington and for those who are on "practice-forecast." It is also done, from time to time, for the local forecast officials and other forecasters at stations. It is usually done by a series of rules of highly elaborate and technical character, which rules are printed in a code of "Special Instructions to Forecasters," and with which the forecaster is expected to be entirely familiar. Under these rules precise definitions are given to matters which can be forecasted. Limits are given to the rise and fall of temperature, definition is given to rain, to "cold wave," and other matters which are subject to forecasting. From these somewhat complicated rules a series of averages is drawn up, and these make the rating which the official receives. It has been found by considerable experience that high ratings and public satisfaction are not necessarily concurrent. The rules for forecasting are so technical as to confine the forecaster to a limited range of



precise expressions, and require in each case a definite forecast, though the forecaster may be unwilling to hazard it on account of uncertain conditions. In cases of this kind it is really better for the public use to give the degree of possibility, probability, or uncertainty under which the forecaster labours from the information which he has in hand. By so doing, however, he loses his high grading in the verification, so that he stands between the Scylla, on the one side, of precise verification, and the Charybdis, on the other, of complete comprehension by the reading public, and he must make his way between them the best he can. It is said to sometimes result in what is called "hedging" in forecasting, where expressions are made with special reference to their values in verification. There is no set of rules that can be drawn up that will absolutely prevent this. Thus one may be given a high verification, but fail in usefulness to the public. The custom has therefore grown up of not paying such close attention to the official rating of verification obtained by the forecaster as to the satisfaction shown by the public in the newspapers and elsewhere. Forecasters have been encouraged to state, without technical limitations of language, exactly what they expect to occur from the data in hand, and to give the public all the information which they have in language which, while condensed, may freely express the amount of confidence which they have in their predictions.

There is also made up and printed with the forecasts a summary of changes in the weather over the United States in the last twenty-four hours, and this is of considerable public interest, and is consulted perhaps as much as the forecasts themselves. By the use of the weather maps and constant consultations of the forecasts, many readers have become so skilful that by means of the summary they can make their own forecasts for their definite purposes, and with more satisfaction to themselves than that afforded by the official forecasts.

In the forecasts a series of different things is predicted. There is a general statement as to the probable changes of the meteorological elements for each district for which forecasts are made. There is also a prediction for local storms, when the forecaster finds indications of them on the maps. When the statement is made that severe local storms may be expected in any particular



district of the United States, it is intended to convey the possibility of the occurrence of tornadoes or cloud-bursts. It is a warning to the public to be on the look-out and to prepare for them. It is thought that in this way the public can be warned of the possibility of the tornado without being terrified by the actual prediction for a quarter of the State, when the tornado will occur in any case in only a very small part of that area. Predictions are also made for high or dangerous winds, and special storm signals are ordered up to convey this information to the public. They are made also for cold waves, for frosts, and for stages of rivers where of interest, and for floods. From the general forecasts specific ones for weather and temperature are taken, which are distributed to inland and country districts. In some cases the local observer can order up cautionary signals at certain ports, also information signals. The latter are intended to notify masters of vessels that additional information can be obtained by calling at the Weather Bureau station, and that this information is of such a nature as to be of importance to them if they are about to leave port. Special bulletins are occasionally sent out when any dangerous storm is in progress, and specific information can be given in the interval between the two daily maps.

Somewhat similar forecasts are made at local or district stations. They are, however, not so elaborate as those made at the central office in Washington; although generally more in detail, they are confined to more limited areas. In general, it is intended that the evening forecasts shall be distributed from the central office from the afternoon observations, and forecasts from the local stations sent out from the morning observations.

The forecasts are, of course, sometimes criticised, as are also the summaries. It is, however, admitted by the general public that all human institutions sometimes go astray, and serious errors occur so seldom as to be excused and overlooked. It is considered more harmful to the public interest to alarm a large area over a doubtful storm than to refrain from mentioning it. The forecast field of the United States is, on the whole, a more favourable one than that of any other country on the globe. It extends from ocean to ocean in the middle latitudes, where storms are more frequent. The storms that come in from Canada can also be

noted before their arrival by means of the telegrams sent to the Bureau from the Canadian stations. Practically the Weather Bureau has an outlook over the entire field of the North American continent, north of Mexico and south of latitude 50°. Over this field the observations are taken at one simultaneous instant. The maps can be made for this large area with more accuracy than can be done in Europe, where a number of weather services occupy a relatively small territory, while observations are taken in different countries at different hours. The only field for meteorological work which approximates that of the United States is that of Australia, but in this case the dry centre of the island or continent disturbs the progress of cyclones over it much more than they are disturbed in the United States by the Rocky Mountains and the dry plains.

“Practice forecasts” are carried on by official forecasters not on duty every day in the year. They make forecasts exactly as if they were making them for the general public. They are verified in exactly the same way. To these gentlemen are also entrusted a series of special problems depending directly upon forecasting. These they work out in detail from the maps already on file, and report. Their reports are taken into account in future forecasts.

The items telegraphed from the stations are (in their proper order): name of station, the corrected readings of pressure and temperature, the direction of wind, state of weather and precipitation, current wind velocity, and minimum or maximum temperature, report of observations of frost, dew-point, upper clouds, lower clouds—except forms of nimbus moving with the surface winds—maximal wind velocity and direction, and special monthly reports when required. This will all be included in eleven words, by the telegraphic code. The code employed by the Bureau is of very ingenious construction, and a long trial has proved it to be very complete and satisfactory. It is dissimilar from any other code in use, and has been invented by employés for the purposes for which it is used. This code is intended only for the use of the Weather Bureau, and is not understood by operators generally. It requires on the part of the observers much study to become familiar with it.

The river and flood work is also under the Forecast Division. In the case of this work the difficulties are very great. Each river has a regimen of its own—its own peculiarities, idiosyncrasies, and characteristics. These must be learned for each river, and they depend largely on the size and character of the basin which the river drains. There is also a difference in the effect of precipitation on the height of the river, with the season at which the precipitation occurs, and with the state and character of the surface of the river basin. Should heavy rains fall in August, after dry weather, they will have a very different effect on the river from that of a heavy rainfall in the spring, when the ground is frozen and the rain carries off with it also the melted snow. There is also a series of difficulties of peculiar character in trying to ascertain and forecast the result of the meeting of flood-crests of rivers. For instance, when the Ohio has a flood-crest at Cincinnati, its tributary, the Cumberland River, has its own flood-crest, and the Tennessee River has still another. These all come into the Lower Ohio, between Cincinnati and the mouth of the river at Cairo. It is a matter of extreme difficulty to know what the result will be on the crest already existing in the Ohio. Will it be accelerated in its progress, or retarded? Will it be heightened, or lengthened? These are among the questions which it is necessary to decide under such circumstances, and the decision of which presents very considerable difficulties. Other disturbances of the flood-crest may occur, as, for instance, when it reaches a certain height the surface water may pour out into some pocket from which the river is separated at lower levels. This is the case with the great St. Francis marshes, which lie in South-Eastern Missouri and North-Eastern Arkansas. Fairly cut off from the main river when the water is low or moderate, they are easily accessible to the water when the Mississippi is high, and amount to an enormous reservoir, which receives the water when high and gives it out slowly, and at a later date.

To aid the observers in their work elaborate river gauges have been placed on the rivers, distributed as experience has found to be most necessary. This is the case with most of the important rivers at the present time, but the service has not reached as yet the streams of secondary importance. It is being gradually

extended, and as time passes these gauges will be found also on the latter streams, and the service will be extended to all river basins of importance in the area covered by it.

Even with this complete apparatus floods occur for which the Bureau can hardly hope to make successful forecasts. As an illustration of these floods, the results of a cloud-burst may be mentioned. For instance, some years ago one occurred on the side of Pike's Peak and the neighbouring mountains. The water poured down a stream of such volume that miles of railway were carried away, and occasionally the steel rails were bent and twisted by the force of the water, and this through a river bed usually dry. Another illustration of this class is to be found in the Johnstown disaster in Pennsylvania. A large reservoir was sustained near the head of a comparatively insignificant stream. This reservoir had a high retaining wall, and had existed for years. Rains in the mountains of rather unusual character, but not altogether exceptional, carried away the retaining wall, and the result was a fearful disaster to the town on the river below. To forecast such a flood as this it would be necessary to have a constant watch kept of the dam enclosing the reservoir. A watchman was employed, but the yielding of the dam was so sudden that it was foreseen by him but a short time before it actually occurred.

#### *Distribution of Forecasts.*

The problems of the distribution of forecasts, after they are made, are quite as important as those involved in making them, and are in some respects more novel. The means actually employed in distributing the forecasts in the meteorological service of the United States are, first, the use of the news-collecting agencies of the newspapers.

The second way of communicating the forecasts to the public is by means of the storm and cautionary signals. These are under the direct control of the forecaster, and he decides after each forecast to which station the telegrams ordering the observer to display these signals shall be sent. There are a number of minor stations for the purpose of display only, and the signal ordered to be displayed at the centre station is also to be displayed



## CHART A.

U.S. DEPARTMENT OF AGRICULTURE, WEATHER BUREAU.

## CAUTIONARY SIGNALS.

(Displayed only on the Great Lakes.)

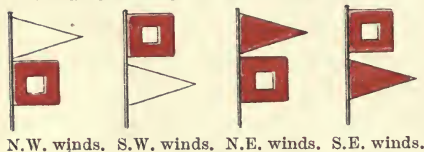

N.W. winds, S.W. winds, N.E. winds, S.E. winds.

## STORM SIGNALS.

(Displayed both on the Lakes and seaboard.)



N.W. winds, S.W. winds, N.E. winds, S.E. winds.

The pennant above the flag indicates that the wind is expected to blow from the northerly quadrants; below, from the southerly quadrants.

EXPLANATION OF CAUTIONARY AND STORM SIGNALS.—A red flag with a white centre, displayed at stations on the Great Lakes, indicates that the winds expected will not be so severe but well-found, seaworthy vessels can meet them without danger.

A red flag with a black centre at stations either on the Lake or seaboard indicates that the storm is expected to be severe.

The pennants displayed with the flags indicate the direction of the wind; red, easterly (from north-east to south); white, westerly (from south-west to north).

## INFORMATION SIGNAL.

The Information Signal consists of a red pennant, and indicates that the local observer has received information from the central office of a storm covering a limited area, dangerous only for vessels about to sail to certain points. The signal is intended to be a notification to shipmasters that valuable information will be given them upon application to the local observer.



Information Signal.

By night a red light will indicate easterly winds, and a white light below a red light will indicate westerly winds.

The system of weather, temperature, and rain signals displayed throughout the country is distinct from the cautionary and storm signals, the latter being principally for the information of maritime interests. They are displayed at the principal ports of the Great Lakes, and on the Atlantic, Pacific, and Gulf coasts.

## HURRICANE WARNINGS.

Two red flags, with black centres, displayed one above the other, indicate the expected approach of tropical hurricanes, and also of those extremely severe and dangerous storms which occasionally move across the Lakes and the Northern Atlantic coast. These warnings are displayed at all Weather Bureau Stations on the Atlantic and Gulf coasts of the United States, and on the following islands in the Atlantic: Jamaica, Santo Domingo, Turks Island, Bermuda, Haiti, Curaçao, Porto Rico, St. Kitts, Dominica, Barbados, Trinidad, Cuba. Hurricane warnings are not displayed at night.

The flags employed are 8 feet square. The pennants are 5-feet hoist, 12-foot fly.



Hurricane Warning



CHART B.

U.S. DEPARTMENT OF AGRICULTURE, WEATHER BUREAU.

EXPLANATION OF FLAG SIGNALS.

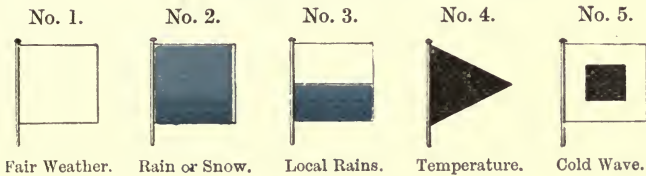

INTERPRETATION OF DISPLAYS.

- No. 1, alone, indicates fair weather, stationary temperature.
- No. 2, alone, indicates rain or snow, stationary temperature.
- No. 3, alone, indicates local rain, stationary temperature.
- No. 1, with No. 4 above it, indicates fair weather, warmer.
- No. 1, with No. 4 below it, indicates fair weather, colder.
- No. 2, with No. 4 above it, indicates warmer weather, rain or snow.
- No. 2, with No. 4 below it, indicates colder weather, rain or snow.
- No. 3, with No. 4 above it, indicates warmer weather with local rains.
- No. 3, with No. 4 below it, indicates colder weather with local rains.
- No. 1, with No. 5 above it, indicates fair weather, cold wave.
- No. 2, with No. 5 above it, indicates wet weather, cold wave.

EXPLANATION OF WHISTLE SIGNALS.

The warning signal, to attract attention, will be a long blast of from fifteen to twenty seconds' duration. After this warning signal has been sounded, long blasts (of from four to six seconds' duration) refer to weather, and short blasts (of from one to three seconds' duration) refer to temperature ; those for weather to be sounded first.

<i>Blasts.</i>			<i>Indicate.</i>
One long	..	..	Fair weather.
Two long	..	..	Rain or snow.
Three long	..	..	Local rains.
One short	..	..	Lower temperature.
Two short	..	..	Higher temperature.
Three short	..	..	Cold wave.

INTERPRETATION OF COMBINATION BLASTS.

- One long, alone .. .. Fair weather, stationary temperature.
- Two long, alone .. .. Rain or snow, stationary temperature.
- One long and one short .. Fair weather, lower temperature.
- Two long and two short .. Rain or snow, higher temperature.
- One long and three short .. Fair weather, cold wave.
- Three long and two short.. Local rains, higher temperature.

By repeating each combination a few times, with an interval of ten seconds between, possibilities of error in reading the forecasts will be avoided, such as may arise from variable winds, or failure to hear the warning signal.

at these minor stations, unless otherwise ordered. The cautionary, storm, and information signals are as given in Chart A. These signals are intended for inland and country districts.

The State Weather Service Division has charge of making or discontinuing these display stations sending signals and receiving reports. The series of flags used is given in Chart B. They are of a very simple and suggestive character, are easily learned by anybody in five minutes, and form, on the whole, the most satisfactory series of signals distributed to the general public.

The Service has made use of a series of railway-train signals. These are signals which are hung on the sides of the baggage or postal car, and can be recognised at a considerable distance by anyone who is in a position to see the passing train. They would be very satisfactory to all within sight of the passing train, were the signals themselves cared for properly. Their care, however, must be left to the employés of the railway, and this is an additional burden placed on their shoulders. The result is, that in some cases they are neglected, and one can occasionally see a railway train bearing fair-weather signals when travelling through a storm.

Another sort of signals which has been used extensively, and which has been found to be fairly satisfactory, is the whistle signal. This is employed only in the case of stationary engines. It produces so little disturbance in the way of whistling as to be generally unobjectionable. But protests are occasionally received. In one case the whistle was located in the vicinity of a Retreat intended for nervous invalids, and caused so much annoyance that it was finally dispensed with. The code consists of a series of long and short whistles, very simple in character and very easy to understand.

The firing of a cannon has also been made use of for the purpose of conveying information concerning the coming weather. It has been employed chiefly to give information concerning frosts. In one notable case it has been given the credit of having saved an entire crop within the range of its hearing.

None of these methods can successfully reach all country communities and individual farms. How to do this is the problem yet to be solved. Among the suggested solutions is

the extension of free delivery of mail, but this would require an enormous expenditure on the part of the general Government—an expense that has been estimated not only in millions, but in hundreds of millions of dollars. Another method proposed is that of the extension of the telephone to farmers' houses. This is entirely practicable, and will perhaps in time be accomplished. Another method proposed is that of small captive balloons, which can be made of different shapes and placed in variable order, and allowed to rise to such a height as to be visible for many miles. A much more promising method for future use is that of the searchlight, rendered possible by the brilliancy of the electric light. As is well known, the shadows of the electric light are easily distinguishable on a cloudy sky, and may be made distinguishable on a clear sky when there is dust in the air. A simple code of signals could be invented which, when projected on low clouds, could be seen through a radius of forty or fifty miles. If they were projected on a clear sky in such a way as to be distinguishable, they could be seen through a radius of much greater distance. This method has been tested to some extent by private enterprise on the top of Mount Washington, and the reports received from it are fairly satisfactory.

The results of the forecasts are to be found in the very great benefits which this foreknowledge of the weather affords to marine and inland commerce and agriculture, and to business of all sorts. The evidences that these benefits are real and numerous exist in the Bureau in very great numbers, and it would be a hopeless task to endeavour to summarise them. To illustrate the character of these advantages, for instance, to commerce, it may be said that in the case of the two very severe hurricanes in the autumn of 1893, which struck inland on the South Atlantic coast and passed northward, warnings were given in abundant time before the hurricanes struck the coast. Numerous illustrations can be found as to the usefulness of the Bureau to trades and professions, where the general public would not suspect that such usefulness could exist. As one instance, it may be mentioned that a firm carrying on the business of artificially curing wood has written to the Bureau that they depend in their business on the forecasts made by the Bureau, and that they regulate their furnaces by them.

The records are also of great use in all sorts of business. It rarely occurs that a railway has a case for damaged fruit but the Bureau is called on to testify in the case. In a great variety of Admiralty cases the decision frequently depends more or less directly on the testimony given by the Bureau as to the direction of the wind and the character of the weather at the time and place the loss occurred.

#### *Scientific Work.*

The methods under which the scientific work of the Bureau has been carried on are various. In the early years of the Bureau a study-room under Professor Abbe was organised, and to this room came all the multitudinous questions, more or less directly scientific, which were sent to the Central Office. There they were carefully studied, and thence the results were issued, either in correspondence or in publications. The scientific works produced by members of the meteorological force have sometimes been printed by the Government. Illustrations of these are found in the cases of Professor Ferrel's work, of the works of Professor Abbe, and of many others. Sometimes the work of the Bureau has been printed by private enterprise, or otherwise than by the Government. The observations taken on Pike's Peak were printed by the Harvard College Observatory. The results of the electrical work, done under the direction of Dr. Mendenhall, were printed by the National Academy of Sciences. The Service has also encouraged the work of those outside its own ranks and given them such aid as it could, and as a result a series of works by eminent men has been published by the Bureau. For instance, those of Professor Loomis and Professor S. P. Langley.

Of the work done in general meteorology we find illustration in the publications of Professor Ferrel, and also in the *Preparatory Studies* made by Professor Abbe. Both of these were printed by the Signal Service as appendices to the annual reports.

In the matter of instruments the work has been more abundant and more detailed. Professor Abbe's *Treatise on Instruments* is an appendix to one of the annual volumes. The late Professor Marvin devoted himself to many sides of the study of instruments. Professor Waldo, while connected with the service, occupied himself with the standardising of the instruments of the service.



The study of storms on the part of the meteorological service has continued from its first establishment. The publication of the Daily Weather Map is really a contribution to this subject, and in addition to this, special maps and bulletins have been issued on many individual storms.

The questions of solar physics, of electricity, and of magnetism, have occupied the service not only directly, but independent studies also have been encouraged by it, and the results have been published by the Service. Dr. T. C. Mendenhall was authorized by General Hazen to organize a special service for the study of atmospheric electricity, and the results of these studies were collected and published for Dr. Mendenhall by the National Academy of Sciences. Professor Bigelow has made a study of the relations of magnetism to meteorology. Clouds have also received the attention of the Bureau officials, and many photographs have been made, and a collection of them has been deposited in the library.

The work of the service in ballooning has been continued from early days in its history.

There have been some studies of spectroscopy and its relations to practical meteorology. Professor Upton, under General Hazen, made a special study of the spectroscope, which was printed as a bulletin. Later, Dr. Jewell, under the direction of Professor Rowland, of Johns Hopkins University, made an elaborate study of some new aspects of this problem which give promise of success in its practical application to forecasting. The subject of the radiation from gases is another of the problems in which the Bureau has interested competent students outside of its ranks.

In climatology the work of the Bureau has been very extensive. A series of climatological monographs has been published on the Western States, on the arid regions, and on the States occupying the great plains. The *Monthly Weather Review*, which has appeared continuously for so many years, has a number of contributions on the subject of climatology. Rainfall has also occupied the attention of the Bureau to a very great degree. The rainfall maps are published regularly in the *Monthly Weather Review*, and many special studies have been printed in atlas form,



or otherwise. The work of the meteorological service has been in some sense brought together and condensed in General Greely's *American Weather*.

As to the meteorological side of agricultural science, the studies of the service have been numerous, but have been for the most part made under the Weather Bureau rather than under the Signal Service.

In 1908 the first number of the *Bulletin* of the Mount Weather Observatory, Virginia, was published, marking an important advance in the practical study of meteorological science. The *Bulletin* has since appeared quarterly, and each number contains more or less detailed accounts of the researches conducted by the staff of the Observatory, of which William J. Humphreys, Ph.D., is the Director, and William R. Blair, Ph.D., is the Assistant Director.

Mount Weather Observatory, the name of a group of laboratories and observatories where the Weather Bureau of the United States has been doing original research work since 1903, is situated in Virginia, on the top of the Blue Ridge Mountains, at a height of 1,725 feet above sea-level, some twenty miles south of Harper's Ferry, and forty-seven miles in a direct line from Washington. The administration building and its contents were totally destroyed by fire on the morning of October 23, 1907, but it soon rose, Phœnix-like, from its ashes, and the third part of the second volume of the *Bulletin* was issued on December 11, 1909. Each part of this important publication is prepared under the direction of Willis L. Moore, D.Sc., LL.D., Chief of the United States Weather Bureau. The *Bulletin* is profusely illustrated, and contains some of the most valuable contributions to the literature of modern meteorology which have been made within the past six years.

## CHAPTER VI

### THE METEOROLOGICAL SERVICE OF THE DOMINION OF CANADA

DURING a recent visit to Canada and the United States (August-September, 1909) I was privileged to visit the new Central Office of the Canadian Meteorological Service, Toronto, Ontario, as well as several of the observatories connected therewith scattered throughout the vast Dominion of Canada. At my request, Mr. R. F. Stupart, the very able Director of the Meteorological Service of Canada, has favoured me with the following account of the establishment and development of that Service.

In response to representations made by the Royal Society of England and the British Association for the Advancement of Science, the Imperial Government in 1840 established an Observatory in Toronto for magnetical and meteorological observations. The land on which the Observatory was located was a block of  $2\frac{1}{2}$  acres, granted by the University for such time as it should be required for scientific purposes.

The operations of the Observatory as an Imperial establishment were brought to a close early in 1853, but were resumed under the authority of the Provincial Government in July of the same year.

During the period that the Observatory was maintained by the Imperial Government it was under the direction of an officer of the Royal Artillery, who was assisted by several non-commissioned officers. When the Provincial Government assumed control of the Observatory, the three non-commissioned officers, who had served during the military régime, resigned from the Army, and continued members of the Observatory staff.

For two years the duties of the Observatory were carried on under the general supervision of the Professor of Natural Philosophy of the University College, Toronto.

In August, 1855, Professor G. T. Kingston was appointed Director.

In 1869 Professor Kingston organised a voluntary meteorological system in Canada.

In the spring of 1871 a grant of \$5,000 was made by the Dominion Government for the promotion of meteorological research, and with a special view of establishing a system of storm-signals. By this time there were forty observers in Canada forwarding weather reports by mail to the Central Office.

In that year, as at the present time, the meteorologist believed that the only possible way of forecasting storms was by means of a map of a large area of the Earth's surface, on which are written symbols, indicating the reading of the barometer, the temperature, direction and velocity of the wind, etc., such information being supplied by telegraph. Maps showing a large portion of North America were then printed in 1871, and, as a commencement, six stations telegraphed weather reports to Toronto three times a day; these were forwarded to the United States Weather Bureau, which Bureau in return furnished reports from fifteen American stations.

In 1872 the grant was increased to \$10,000, the number of stations reporting was increased to eight, and storm-signal masts were erected at various ports on the great lakes and in the maritime provinces. The staff of the Observatory was, at the commencement of 1873, composed of the Director, the Assistant Director, and six others, including a messenger.

Up to the autumn of 1876 the Canadian Service depended wholly on the judgment of the United States Bureau for the issue of storm warnings, which, on advice from Washington, were distributed from Toronto. In September, 1876, warnings were independently issued from Toronto, and in October daily forecasts were issued to some points in the older provinces. At the close of 1876 there were about 120 observers in correspondence with the Toronto Office, and there were 37 storm-signal display stations. The Central Office staff included 12 persons.

Early in 1880 Professor Kingston resigned office, and Mr. Charles Carpmael, M.A., late Fellow of St. John's College, Cambridge, was appointed as his successor. At the close of that year

there were 140 observers in Canada, 18 telegraph reporting stations, and 44 storm-signal stations. The staff of the Central Office numbered 17 persons. The *Annual Climatological Report* in that year was an octavo volume of 365 pages.

In the year 1894 there were 268 climatological stations, 29 stations reporting by telegraph to the Central Office, and 65 storm-signal stations. The publications were an *Annual Climatological Report*—an octavo volume of about 350 pages; a *Monthly Weather Review*, somewhat similar to that published at the present time; and a *Toronto Meteorological Register*. Forecasts were issued once a day in the evening to about 1,500 places in Canada.

The present Director, Mr. R. F. Stupart, was appointed by Order in Council dated December 28, 1894.

On February 6, 1895, a map showing the climatic conditions of the month just closed was published for the first time.

The *Annual Climatological Report* for 1895 is a quarto volume of 274 pages, and contains charts showing the average climatic conditions of the Canadian summer months.

In August of the year 1896 a daily map was first published, and forecasts published in the forenoon, covering the current and following days, were first issued to a large number of stations, more particularly on the Great Lakes and in the Maritime Provinces, the object being to give better information to mariners.

In 1900 arrangements were made with the Telegraph Company to manifold a daily meteorological bulletin, and post it at numerous places in some of the larger cities of Ontario, Quebec, and the Maritime Provinces. It was about the year named that the publication of the morning issue of forecasts covering the current and following day became almost general in the afternoon newspapers.

In 1904 a comprehensive *Daily Weather Bulletin*, containing weather reports from a large number of stations in the wheat belt, was during the summer for the first time published in Winnipeg and many other important agricultural centres of the North-West. This *Bulletin* has since been increased in size, and is distributed very freely in the West.

On July 2, 1907, the *Daily Weather Map*, hitherto manifolded by the mimeograph, was first printed.



The Meteorological Service is a branch of the Governmental Department of Marine and Fisheries. Its Central Office, newly erected and admirably equipped, is in Bloor Street, Toronto, Ontario.

A general statement of the equipment and work of the Meteorological Service in 1907 shows the following facts :

Number of persons, all told, employed in the Central Office, Toronto.. .. .	24
Number of persons receiving pay from the Meteorological Service .. .. .	238
Number of stations reporting by telegraph to the Central Office .. .. .	39
Number of storm-signal stations in operation .. .. .	89
Number of climatological stations .. .. .	445

The Government "Appropriation" for the year 1909 amounted to \$129,300, together with a supplemental grant of \$3,200 for a magnetic observatory in connection with the Central Office—\$132,500 in all.

#### PUBLICATIONS COMPILED AT THE CENTRAL OFFICE.

*The Annual Climatological Report* : Last issue a quarto volume of 440 pages.

*The Monthly Weather Review* : A brochure of 12 pages, containing climatological data from about 300 stations, a general synopsis of weather conditions, etc.

*The Monthly Map* : Published three days after the close of each month, showing the temperature conditions which have obtained—departures from average, together with rainfall and snowfall, information regarding crops, and the general outlook.

*The Daily Map* is compiled and printed in the Central Office.

*The Toronto Meteorological Register*, which has been published for over sixty years, and is still continued.

#### WEATHER FORECASTS.

Weather forecasts, covering thirty-six hours in advance, and sometimes a longer interval, are issued twice daily throughout the year. The weather charts on which the forecasts are based have entered on them information obtained by telegraph from thirty-seven stations in Canada and sixty-four stations in the

United States ; also reports from St. John's and Bermuda. The forenoon chart is ready for inspection ordinarily about 9.45 a.m., and the forecast official, having drawn the isobars, first issues a bulletin for the Maritime Provinces, including forecasts for the current day and following day for Nova Scotia, New Brunswick, and Prince Edward Island, and also for vessels leaving for the Great Banks and for American ports. Then follows a forecast for the Western Provinces, which is telegraphed without delay to Winnipeg, where a local agent, who has meanwhile received weather telegrams from some twenty-three points additional to those received in Toronto, prepares a bulletin giving a general synopsis of existing weather conditions, and also includes all weather reports received, together with the forecasts from Toronto. This bulletin is then distributed in Winnipeg, and telegraphed to the more important centres in the Prairie Provinces. The Central Office forecast official lastly prepares a bulletin for Ontario and Quebec, which is usually despatched about 10.10 a.m., and is published very widely by the afternoon press, as well as being posted at telegraph-offices, post-offices, and other frequented places. At all the larger towns in these Provinces a special effort has been made to have these bulletins exposed on wharves and docks within easy reach of shipping people and fishermen.

The evening weather chart, like that of the morning, is usually ready for inspection about 9.45 p.m., and with as little delay as possible a bulletin is prepared for the press, and forecasts are issued for all parts of the Dominion, exclusive of British Columbia. These forecasts are distributed by the telegraph companies to most of the telegraph-offices in the Dominion, and, by arrangements, are posted up in a frame hung in a conspicuous place, and nearly every morning newspaper publishes them, generally on the front page.

During the winter months a very large number of special forecasts are made for shippers of perishable goods, inquiries being made both by telephone and telegraph. Indeed, there is little reason to doubt that nearly all shippers of such goods in the Dominion now consult the Weather Service before sending forward consignments.

During the winter special warnings of snow and drift are issued to

all Canadian railways, whenever it is decided that this is necessary. Various electric railways also have made a practice of consulting the Central Office as to the weather of the coming night, the information supplied enabling them either to reduce the working staff on duty to a minimum, or, on the other hand, to take unusual measures to prevent snow blockades.

During the late autumn many telegrams are received from vessel-masters wishing to cross the Lakes, requesting special forecasts as to probable winds and weather, and, indeed, in some cases asking a direct opinion as to the advisableness of starting.

Forecasts and storm-warnings for British Columbia are issued from Victoria, to which place are telegraphed reports from all Canadian stations west of White River, together with some twenty-five reports from the Pacific States.

The Meteorological Service supplies the meteorological and climatic data to the agricultural departments of the various Provincial Governments, and this entails much work in the Central Office. It is a significant fact that the Government of the North-West Territories for some years has reprinted the crop report from the *Monthly Map* published by the Meteorological Service.

The old bench-mark on the south side of the former Central Observatory at Toronto was 350 feet above mean sea-level. The International Deep Water Ways Commission between the United States and Canada have adopted 249·5 feet as the mean level of Lake Ontario above the sea. The new Central Observatory stands at least 100 feet above the level of the lake, from the northern shore of which the city of Toronto rises by a tolerably steep gradient.

## CHAPTER VII

### AIR TEMPERATURE AND ITS MEASUREMENT

No other meteorological factor exercises a more potent influence over the animal and vegetable kingdoms than does temperature. Hence we may fitly commence our study of the weather with an account of the instrument which is in daily use for the purpose of *measuring* the *warmth* of the air—namely, the thermometer (Greek, *θέρμη*, *heat*; *μέτρον*, *a measure*). The principle of the instrument is that it measures temperature by the expansion of bodies.

In the writings of two Greek physicists, Philo of Byzantium, who lived in the third century B.C., and Hero of Alexandria, of a later though undetermined date, we find descriptions of an apparatus which represents the primitive idea of the thermoscope.

Philo's description in his work, *De Ingeniis Spiritualibus* ("On Pressure Engines") is given as follows by Professor Hellmann:<sup>1</sup>

"One takes a leaden globe of moderate size, the inside of which is empty and roomy (Fig. 2). It must neither be too thin, that it cannot easily burst, nor too heavy, but quite dry, so that the experiment may succeed. Through an aperture in the top is passed a bent siphon, reaching nearly to the bottom. The other end of this siphon is passed into a vessel filled with water, also reaching nearly to the bottom, so that water may the more easily flow out—*a* is the globe, *b* the siphon, and *g* the vessel. I assert, when the globe is placed in the sun and becomes warm, some of the air inclosed in the tube will pass out. This will be seen, since the air flows out of the tube into the water, setting it in motion and

<sup>1</sup> "The Dawn of Meteorology," *Quarterly Journal of the Royal Meteorological Society*, October, 1908, vol. xxxiv., No. 148, p. 227.



producing air-bubbles one after the other. If the globe is placed in the shadow, or any other place where the sun does not penetrate, then the water will rise through the tube flowing into the globe. If the globe is again placed in the sun, the water will return to the vessel, and *vice versâ*. . . . The same effect is produced if one heats the globe with fire or pours hot water over it. . . .”

Somewhat more complicated is the similar apparatus of Hero, to which he gives the name  $\lambda\iota\beta\acute{\alpha}\varsigma$ , or drip.

The thermometer is supposed to have been invented by Sanctorio, of Padua, in 1590; but the history of the instrument is involved in obscurity until 1714, when Fahrenheit, of Dantzic, constructed the thermometer which bears his name. He used

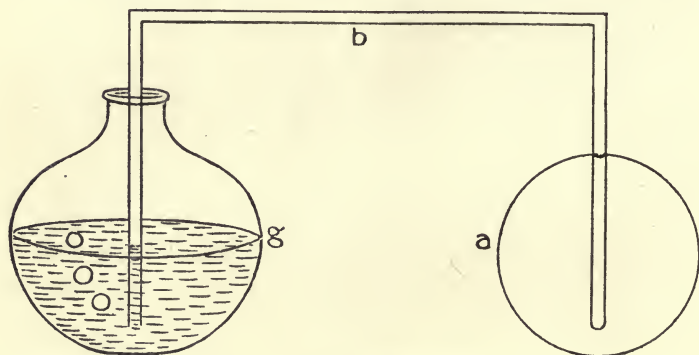

FIG. 2.—PHILO'S THERMOSCOPE.

mercury instead of spirit of wine, and introduced a scale, graduated from the melting-point of ice to the boiling-point of water at sea-level, and under ordinary conditions of temperature and pressure. Fahrenheit arrived at his zero point in a curious way. He is believed to have held that for all practical purposes the lowest temperature likely to call for registration was that reached in an Icelandic winter. It is, however, more likely that his zero was fixed by experiment with a freezing mixture of snow and chloride of sodium (common salt) or of snow and chloride of ammonium (sal ammoniac).

Counting, then, from zero, Fahrenheit made the melting-point of ice  $32^{\circ}$  and the boiling-point of water  $212^{\circ}$ , thus dividing the

distance between these two crucial points into  $180^\circ$ , or half the number of degrees in a circle ( $360^\circ$ ). This scale is commonly used throughout the British Dominions and in the United States of America. Its advantages are that, under ordinary circumstances, the *minus* sign ( $-$ ) is not required, while the smallness of the degrees permits very accurate measurements of temperature.

Mercury was selected as the medium for indicating temperature, because (1) of its equal expansion at different temperatures—equal increments of bulk corresponding to equal increments of temperature; (2) of its low freezing-point ( $-37.9^\circ$  F.), its high boiling-point ( $675.1^\circ$  F.), its high conductivity of heat, its purity, its property of not wetting glass, its low vapour pressure, and its low specific heat, or “the amount of heat required to raise 1 pound of mercury one degree, in terms of that necessary to raise 1 pound of water one degree” (R. H. Scott). Dr. Thomas Young<sup>1</sup> defined the degree Fahrenheit as corresponding to an expansion of mercury equal to  $\frac{1}{10000}$  part of its volume or bulk. This is absolutely true at a temperature of  $142^\circ$  F. For the recording of temperatures below its freezing-point, mercury is replaced by spirit, which medium is also used because of its transparency in the construction of the minimum thermometer in common use. In this instrument a small and light float of glass or enamel, called the “index,” is immersed in the spirit. Hence it is necessary that the spirit should be transparent in order that the exact position of the index may be observed.

In 1742 Celsius, Professor of Astronomy in the University of Upsala, in Sweden, divided the scale of the mercurial thermometer between the melting-point of ice and the boiling-point of water into  $100^\circ$ . According to this scale, therefore, the melting-point of ice is zero, and the boiling-point of water is  $100^\circ$  at an atmospherical pressure of 760 millimètres (29.922 inches) in the latitude of Paris. Hence the name *Centigrade*, by which this thermometer is usually known. It is extensively used on the Continent of Europe, and, indeed, by scientific men of all nations.

A third thermometer scale is that introduced about 1731 by Réaumur, a French physicist, who was born at La Rochelle in 1683. According to this scale there are only  $80^\circ$  between zero,

<sup>1</sup> *Lectures on Natural Philosophy*, p. 485.

the melting-point of ice, and the boiling-point of water. The Réaumur scale is still used in Russia and parts of Germany, but the Celsius or Centigrade thermometer scale is rapidly superseding it in those countries.

The following figures, copied from Chambers's *Encyclopædia* (art. "Thermometer"), will render the relations of these three scales easily understood :

Fahrenheit	..	..	0°	32°	77°	122°	212°
Réaumur	..	..	—	0°	20°	40°	80°
Centigrade	..	..	—	0°	25°	50°	100°

To reduce a reading taken by one scale to the corresponding reading taken by another becomes quite easy, if we remember the primary relations of the scales to one another—namely,  $80^{\circ}$  R. =  $100^{\circ}$  C. =  $180^{\circ}$  F. ; or in the most simple form :  $4^{\circ}$  R. =  $5^{\circ}$  C. =  $9^{\circ}$  F. The only element of difficulty is the management of  $32^{\circ}$  F., which corresponds to the zero of the other scales. It is quite clear that when we are reducing Fahrenheit to Centigrade or Réaumur, we must take away, or subtract,  $32^{\circ}$  from the given Fahrenheit reading ; whereas in reducing either of the other scales to Fahrenheit, we must add  $32^{\circ}$  to the result.

The following proportional statements may be of use :

1. For Fahrenheit's thermometer :

$$F. : R. :: 180 : 80, \text{ i.e., } 9 : 4. \quad \text{Therefore } F. = \frac{9R.}{4} + 32^{\circ}.$$

$$F. : C. :: 180 : 100, \text{ i.e., } 9 : 5. \quad \text{Therefore } F. = \frac{9C.}{5} + 32^{\circ}.$$

2. For Celsius' thermometer :

$$C. : F. :: 100 : 180, \text{ i.e., } 5 : 9. \quad \text{Therefore } C. = \frac{(F. - 32) \times 5}{9}$$

$$C. : R. :: 100 : 80, \text{ i.e., } 5 : 4. \quad \text{Therefore } C. = \frac{5R.}{4}$$

3. For Réaumur's thermometer :

$$R. : F. :: 80 : 180, \text{ i.e., } 4 : 9. \quad \text{Therefore } R. = \frac{(F. - 32) \times 4}{9}$$

$$R. : C. :: 80 : 100, \text{ i.e., } 4 : 5. \quad \text{Therefore } R. = \frac{4C.}{5}$$

In speaking of the fixed points on the thermometer scale it will be observed that the expressions used have been "the melting-point of ice" and the "boiling-point of water."

The melting-point of ice is exactly  $32^{\circ}$  F., and  $0^{\circ}$  of both the Centigrade and Réaumur scales. The phrase is used in preference to the "freezing-point of water," because water, if perfectly still, may be chilled several degrees below  $32^{\circ}$  F. without freezing. Under such circumstances, if it is suddenly agitated, it will congeal instantly. Again, water which holds a salt in solution has a freezing-point considerably below  $32^{\circ}$  F. Only distilled water is admissible in these delicate experiments.

The boiling-point of water is a still more variable quantity than the freezing-point, and hence the term must be qualified by the addition of the words "at mean sea-level, the barometer standing at 29.905 inches in the latitude of London." The French standard of pressure already referred to is 760 millimètres in the latitude of Paris. Ebullition takes place the moment the tension of the vapour of water equals the atmospheric pressure. It is evident that the lower the pressure, the more easily will vapour escape from heated water, giving rise to the phenomenon known as "ebullition" or boiling. The converse is equally true, and under a pressure of fifty atmospheres the boiling-point of water is raised to  $510^{\circ}$  F. In fact, water can be heated to almost any degree without boiling, provided it is subjected to a sufficient pressure.

As a matter of fact, the boiling-point falls one degree of Fahrenheit's scale for every 0.589 inch of barometric fall at moderate heights. Accordingly, should the barometer fall to 27.549 inches at sea-level—and this actually occurred on January 24, 1884, and, more recently, on December 8, 1886—the boiling-point would be  $208^{\circ}$  instead of  $212^{\circ}$ . A still more striking variation in the boiling-point occurs at great elevations. For instance, at Quito, in Mexico, 9,000 feet above the sea, water boils at  $194^{\circ}$  F.; on the summit of Mont Blanc (15,781 feet) at  $183^{\circ}$  F.; and on Gaurisankar, or Mount Everest, the highest peak of the Himalayas (29,002 feet), it would boil at  $158^{\circ}$  F., were it possible to make the experiment. Advantage has actually been taken of this dependence of the boiling-point on elevation to roughly measure the heights of mountains. Mr. R. Strachan, F.R.Met.Soc., suggests a simple rule for ascertaining the relative elevation of two stations. It is to multiply by 9 the difference



in barometrical readings between them, taken in hundredths of an inch. The result gives the difference in feet between the stations. This rule depends on the principle that the difference of height corresponding to a difference in barometrical readings of 0.1 inch is approximately 90 feet. For instance, for the change of level from 200 to 290 feet, the difference in barometrical readings (the sea-level reading being 30 inches) is 0.101 inch at  $40^\circ$  and 0.098 inch at  $50^\circ$  (R. H. Scott).

In the case of the Centigrade and Réaumur scales, all temperatures below the melting-point of ice have a minus sign (–) prefixed. In the case of the Fahrenheit scale the zero point is  $32^\circ$  below the melting-point of ice. The minus sign is, therefore, very seldom required for temperatures occurring in the British Isles. The value  $-40^\circ$  represents the same temperature on the Fahrenheit and Centigrade scales.

A thermometer consists of a capillary glass tube, of uniform bore and blown at one end into a bulb, which is then filled with mercury or spirit, and finally the tube is hermetically sealed at the other end. Any given temperature is measured by the amount of expansion undergone by the liquid in the bulb when exposed to that temperature. The liquid moves up the capillary tube from the bulb as temperature rises, and retreats towards the bulb as temperature falls. In all cases, the scale of degrees by which the readings are made should *be engraved on the glass tube itself*—that is, on the stem.

The steps in the construction of a thermometer are four in number: (1) calibrating the tube; (2) filling; (3) “curing”; (4) graduation.

(1) Uniformity of calibre is attained in glass-blowing by introducing a bead of mercury, say an inch in length, and noting by measurement if this thread of the liquid metal occupies the same extent of the tube at different points.

(2) The thermometer is filled, after blowing a bulb at the bottom, by filling a small funnel at the top with mercury and then expelling the air in part from the bulb by heat. As the bulb cools, a vacuum is formed, to fill up which some of the mercury slips back from the funnel into the bulb. The process is repeated until the bulb is quite filled with mercury.

(3) "Curing" is referred to afterwards. The process consists in laying the instrument aside for a year or so after filling, so that the glass may assume a permanent shape, or "season," and so obviate the error known as "displacement of zero." Denton has introduced a method by which this can now be done in as many days as it used to take months.

(4) Graduation is the marking of the scale on the thermometer stem, the fixed points of temperature of melting ice ( $32^{\circ}$  F.), and of the vapour (steam) of water boiling at a pressure of 29.905 inches—that is, the pressure of one standard atmosphere in the latitude of London ( $212^{\circ}$  F.)—being duly ascertained by direct experiment in each case.

## CHAPTER VIII

### THERMOMETERS

THE thermometers used in meteorological observatories are standard thermometers, ordinary thermometers, registering thermometers, self-recording thermometers, and radiation thermometers.

1. A *standard thermometer* is made with every precaution to secure accuracy. It is not intended for daily use, but only for testing from time to time the correctness of the ordinary thermometers with which observations are made. The scale should not be cut on the stem for several years after the carefully selected tube and bulb have been filled. This delay is necessary in order to guard against the defect called the "displacement of zero," by which a thermometer is made to read too high. This defect arises from the gradual contraction of the bulb which results from the slowness with which fused glass returns to its original density. Of course, as the bulb contracts, it holds less mercury, which is forced into the tube to a higher level than the temperature warrants. Except for use in extremely cold climates, a standard thermometer should be made with mercury, because of the uniform rate of expansion of this metal. Its scale should range from far below zero to the boiling-point of water.

2. *Ordinary thermometers* should be constructed of mercury. They should be scaled from  $-40^{\circ}$  to  $110^{\circ}$  or  $120^{\circ}$ . In the British Isles a range from  $-15^{\circ}$  or  $-10^{\circ}$  to  $100^{\circ}$  is ample. In every case an ordinary thermometer should carry with it a certificate of verification at Kew Observatory, or other recognised scientific institution. At least once a year each instrument should be tested for the "displacement of zero," by being plunged into a mass of melting snow or ice.

The Kew Observatory Thermometer (Fig. 3) is an excellent instrument, particularly adapted for taking reliable observations at sea, as it is proof against the corrosive action of salt water and of damp, and is protected by a copper case. This thermometer is 12 inches long, with the degrees etched on the stem, and the figures indelibly burned on the porcelain scale, which ranges from  $0^{\circ}$  to  $120^{\circ}$  F. It is made after the Meteorological Office and Admiralty pattern, and carries with it a certificate of verification at Kew Observatory.

3. *Registering thermometers* are so constructed as to enable us to read off from them the highest or lowest temperature to which they have been exposed in a given length of time—usually twenty-four hours. As it is too inconvenient to read these instruments at the close of a civil day—that is, at midnight—they are by arrangement read at the latest observing hour of the day, or 9 p.m. in the British Isles. The thermometer which is used for registering the highest or maximal temperature of the day of twenty-four hours is called a “maximum thermometer.” Similarly, that which registers the lowest or minimal temperature is called a “minimum thermometer.” In both maximum and minimum thermometers the contrivance by means of which we are able to read the extremes of temperature is called the “index.”

*Maximum thermometers* are of two kinds, called after their designers, Phillips’s and Negretti and Zambra’s.

In the instrument invented by Professor Phillips, F.R.S., of Oxford (Fig. 4, A), the index is really a small fragment of the column of mercury, separated from the main body by a tiny bubble of air. When the column expands, this fragment is pushed before it; but when the column contracts, it remains behind in the capillary tube, so marking the point of highest temperature. This delicate arrangement is apt to get out of order, the air bubble being displaced, and so permitting the index to coalesce with the main thread or column of



FIG. 3.—KEW OBSERVATORY THERMOMETER.



mercury, thus converting the instrument into an ordinary thermometer.

Negretti and Zambra devised a plan which is as ingenious as it is simple (Fig. 4, B). The mercurial thread in the thermometer tube forms itself the index in this way : the bore of the tube is bent at a sharp angle and so much reduced in calibre close to the bulb that, while the expansion of the mercury in the bulb is quite capable of forcing the liquid past the constriction into the tube ; on cooling, the portion of mercury which has so passed into the tube breaks off from the main body, and remains in the tube to register the highest point to which it had reached. In fact, when contracting, cohesion fails, and the mercury in the bulb is unable

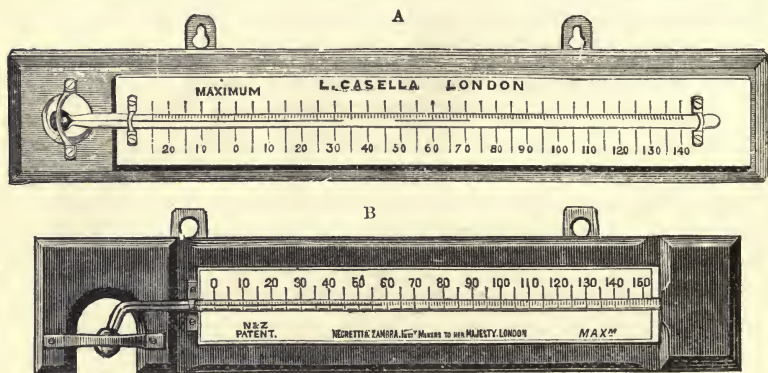

FIG. 4.—A, PHILLIPS'S, AND B, NEGRETTI AND ZAMBRA'S MAXIMUM THERMOMETERS.

to draw back the portion in the tube, a separation taking place where the tube is both bent and constricted.

The maximum thermometer should be suspended in the thermometer stand or Stevenson screen horizontally, or almost horizontally. The bulb end should be gently and slightly depressed before reading, so as to secure that the index is in apposition with the constriction in the tube at the near or bulb end. Great care should be taken to handle the instruments as little as possible while reading them ; otherwise erroneous records may result.

These thermometers are both set in the same way. They are taken in the hand and swung gently bulb downwards or else they may be lightly tapped, bulb downwards, on the wooden

ledge of the stand. In this way the instrument becomes for the time being an ordinary thermometer, showing the existing temperature of the surrounding air.

Maximum thermometers are liable to two defects :

1. The mercury may recede from its maximal position to a greater or less extent when the temperature subsequently falls. The observer should accordingly test the instrument occasionally by heating it and noting whether the mercury column retains its position in the tube.

2. The mercury may slip forward when the instrument is brought into a horizontal position after setting.

These defects may be remedied in most cases by altering the inclination at which the instrument hangs. Should they persist, the thermometer must be rejected (*The Observer's Handbook*, Meteorological Office, London, 1908).

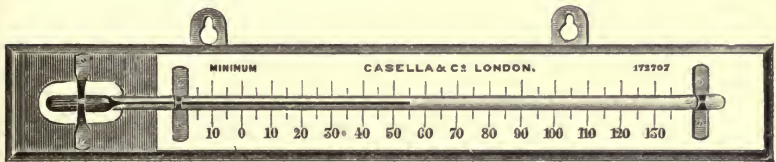

FIG. 5.—RUTHERFORD'S MINIMUM THERMOMETER, FILLED WITH PURE ALCOHOL FOR ORDINARY REGISTRATION, ENGINE-DIVIDED ON THE STEM.

*Minimum thermometers* are also of two kinds—Casella's, a mercurial thermometer; Rutherford's, a spirit thermometer. The former is a beautiful instrument, and especially adapted for use in tropical climates, where the intense heat by day causes spirit to volatilise quickly. The latter is the minimum thermometer which is in almost universal use at our home and colonial stations (Fig. 5). In its construction a small metallic index is immersed in the spirit. Before using, this index is allowed to run down to the end of the column of liquid by sloping the thermometer with the bulb uppermost. In this way the thermometer is "set." It should then be placed in a nearly horizontal position in the screen, any slight inclination being towards the bulb, so as to facilitate the backward movement of the index when the spirit contracts with a falling temperature. When this happens, the index is drawn back with the spirit by

the force of capillary attraction. On a rise of temperature taking place, the spirit expands and flows past the index, which remains behind to mark the lowest or minimum temperature.

A spirit thermometer such as that just described should be carefully watched and periodically compared with a reliable mercurial thermometer, for some of the spirit is apt to volatilise and afterwards to condense in the distal or further end of the tube, causing the instrument to read too low by two, three, or even more degrees.

Such an accident is easily remedied by swinging the thermometer backwards and forwards, bulb downwards. It may, however, be necessary to cautiously heat the distal end of the tube in the flame, or near the flame, of a spirit-lamp. This causes the condensed spirit again to volatilise. If the instrument is then cooled in the position bulb downwards, the freshly condensed spirit will gradually trickle downwards and join the main body of the liquid.

Spirit thermometers are by no means as sensitive as mercurial ones, mercury having a much lower specific heat and a much higher conductivity than alcohol. Hence it is becoming usual to make the bulb of the spirit thermometer of such a shape—forked or cylindrical—that as large a surface of the spirit as possible shall be exposed to the action of the air.

Mention should be made of the registering thermometers which were devised in the eighteenth century, but which are now discarded as useless for scientific purposes. In 1757 Lord Charles Cavendish, a Vice-President of the Royal Society, read a paper before the Society on a maximum thermometer and a minimum thermometer which he had designed. This paper will be found in the fiftieth volume of the *Philosophical Transactions* (p. 300). His instruments suggested to Mr. James Six, a quarter of a century later (in 1782), the idea of an improved registering thermometer, which has ever since been known as “Six’s Thermometer” (Fig. 6). It combines in one instrument a maximum and a minimum thermometer. It consists of a long tube bent parallel to itself in the centre like a siphon, and terminating at each extremity in a bulb, one of which bulbs is larger than the other. The bend of the tube is filled with a plug of mercury.

The remainder of the tube and both bulbs are filled with spirit, but in the smaller bulb there is also a bubble of highly compressed air. A small needle index of steel, with a capillary filament attached to it, floats on each end of the plug of mercury.

As temperature rises, the spirit in the larger bulb expands, and pushes the mercurial plug with one of the indexes in front of it into the distal tube. When temperature falls, the spirit, of course, contracts, and the elasticity of the compressed-air bubble in the distal bulb causes the mercury to pass back after the retreating spirit, the distal index remaining behind to mark the point of highest temperature. But as the mercury passes back into the proximal tube, it pushes the other index before it towards the larger bulb until temperature ceases to fall. When this happens, the proximal index remains to mark the lowest temperature.

The indexes, being of steel, can be "set" for a new observation by means of a magnet—in this way by attraction they are drawn back to the surface of each end of the plug of mercury.

Since a mercurial minimum thermometer is much better suited for use in hot climates than a spirit thermometer, it may be well to describe Casella's ingenious instrument at some length. Mercury is the only fluid employed in its make. The bulb and column are of the same size as in the standard maximum thermometer, and cold is thus registered under precisely the same conditions as heat. No steel or other index is employed. In this thermometer advantage is taken of a curious property of mercury which tends to adhere to glass *in vacuo*.

Various experiments were undertaken by Mr. Louis P. Casella, F.R.Met.Soc., for the purpose of discovering some means by which in a mercurial thermometer the mercury itself might be detained at the point of lowest temperature, and so serve as a

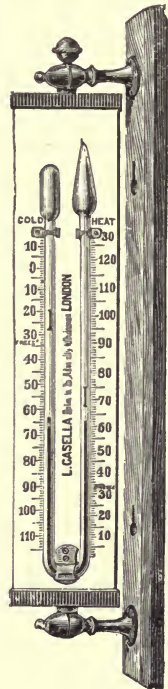

FIG. 6.  
SIX'S THERMOMETER.



self-registering minimum thermometer. It occurred to him that the adhesive property of mercury for glass *in vacuo*—together with the fact that, where two tubes are united to one bulb, this fluid will rise by expansion in the larger, and recede by contraction in the smaller, tube—might enable him to attain his object. The result was the invention of probably the first instrument known to register past indications without having or forming any separate index.

The general form and arrangement of this instrument are shown in the accompanying illustrations (Fig. 7), of which the upper drawing represents a full-sized section. A tube with large bore is made to come off from the upper side of the thermometer stem a short distance in front of the bulb. At the distal end of



FIG. 7.—CASELLA'S MERCURIAL MINIMUM THERMOMETER.

this large-bored tube a flat glass diaphragm is formed by the abrupt junction of a small pear-shaped chamber (*ab*), the inlet to which at *b* is larger than the bore of the indicating tube or stem of the thermometer.

The thermometer being set, as temperature falls, the mercury in the bulb contracts and withdraws the fluid in the stem only. When the minimum temperature is reached, the mercurial column in the stem marks it, not only at the moment, but afterwards also; for as soon as the mercury in the bulb begins to expand with a rise of temperature, it finds an easier passage into the tube of larger bore, and through it into the pear-shaped chamber beyond. In the tube of smaller bore—that is, the stem of the thermometer—adhesion or capillary attraction holds the mercury, and prevents its recession from the point indicating the



lowest temperature that had been reached since the instrument was set.

To set the thermometer, it should be placed in a horizontal position, with the back plate suspended on a nail, and the lower part supported on a hook. The bulb end may now be gently raised or lowered, causing the mercury to flow slowly until the bent part is full and the chamber (*ab*) is quite empty. At this point the flow of mercury in the long stem of the thermometer is arrested, and indicates the exact temperature of the bulb—that is, of the air—at the time. When out of use, or after transit, it may happen that, on raising the bulb, the mercury will not at first flow out from the small chamber (*ab*). In such a case, however, a slight tap with the hand on the opposite end of the instrument, with the bulb uppermost, will readily cause it to do so.

The readings of maximum and minimum thermometers should be compared regularly with those of an ordinary thermometer placed beside them to check their action and to determine the corrections which should be applied to them.

The maximum and minimum thermometers, the ordinary or dry-bulb thermometer, and the wet-bulb thermometer, by which the temperature of evaporation is shown, as will be afterwards described,<sup>1</sup> should all be suspended in a suitable screen or thermometer stand facing north.

Thermometers should be protected from the direct or reflected rays of the sun, but at the same time should be freely exposed to the open air. These ends are best attained by placing them in a thermometer stand, such as the louvre-boarded box designed by Mr. Thomas Stevenson, C.E., of Edinburgh—hence called the Stevenson stand or screen (Fig. 8). The pattern of this screen, which has been approved by the Royal Meteorological Society, is described in the *Quarterly Journal* of the Society (vol. x., p. 92, 1884). The screen is a double-louvred box, its interior being 18 inches long, 11 inches wide, and 15 inches high. It has a double roof, the upper one projecting 2 inches beyond the body of the screen on all sides, and sloping from front to back. The front is hinged as a door, and opens downwards. The thermometers are suspended on uprights near the middle of the screen,

<sup>1</sup> See p. 181.

which should be painted white within and without, the finishing coat consisting of white paint and copal varnish. It is desirable that the woodwork should be repainted in the spring of each year. The screen should be mounted on four stout posts over short grass and freely exposed. The posts should penetrate the ground to a depth of fully 2 feet, and the soil surrounding them should

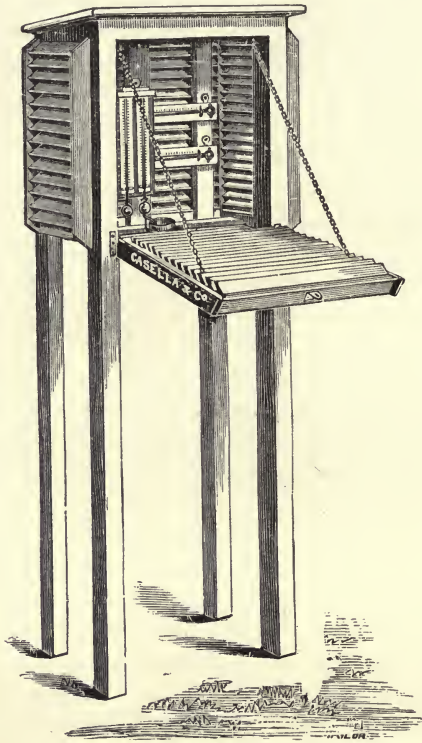

FIG. 8.—STEVENSON'S THERMOMETER STAND.

be well rammed down. The screen should be arranged so that the bulbs of the dry and wet thermometers shall be 4 feet above the ground. It should not stand in the shade or within 10 feet of any wall, particularly of one with a southern aspect. The door of the screen should open towards the north. It will be a convenience to have a wooden rack placed on the grass imme-

diately in front of the screen for the observer to stand on when reading the thermometers.

In towns, at many telegraphic stations, and on board ship, a "wall screen" must take the place of the freely exposed Stevenson stand just described. It consists of a covered case, with louvred wings, fixed on a wall facing north, at the height of 4 feet from the ground, by means of large hold-fasts.

The Stevenson thermometer screen is hardly suitable for use in tropical countries. The following arrangements have been recommended by the Committee of the British Association on the Climate of Tropical Africa :

The thermometers should be placed within an iron cage, which should at all times be kept locked, so as to prevent interference with the instruments. This cage should be suspended under a thatched shelter, which should be situated in an open spot at some distance from buildings, must be well ventilated, and should guard the instruments from exposure to sunshine or rain, or to radiation from the ground. A simple hut, made of materials available on the spot, would answer this purpose. A gabled roof with broad eaves, the ridge of which runs from north to south, is fixed upon four posts, standing 4 feet apart. Two additional posts may be introduced to support the ends of the ridge beam. The roof at each end projects about 18 inches. In it are two ventilating holes. The tops of the posts are connected by bars or rails, and from a crossbar is suspended the iron cage with the thermometers. These will then be at a height of 6 feet above the ground. The gable ends may be permanently covered in with mats or louvre-work, not interfering with the free circulation of the air, or the hut may be circular. The roof may be covered with palm-fronds, grass, or any other material locally used by the natives as building material. The floor should not be bare, but covered with grass or low shrubs. Care must be taken to fix the cage firmly, so that the maximum and minimum thermometers may not be disturbed by vibration.

The International Meteorological Committee, at Vienna in 1873, and again at Rome in 1879, expressed the opinion that exposure of thermometers in a space which is open and accessible

to all winds, and at a height of  $1\frac{1}{2}$  to 2 metres, is, as a rule, the most suitable, though not always practicable.

The Royal Meteorological Society recommends that the observations with the thermometers just described should be made as follows: Having opened the screen, the dry and wet bulb thermometers are to be read first, so that they may not be affected by the nearness of the observer. The maximum thermometer is to be read next, by noting the point at which the end of the column of mercury is lying. The minimum thermometer is read last, by noting the position of the end of the index furthest from the bulb. The surface of the column of spirit shows the temperature at the time of observation. A second reading of all the thermometers should be taken to guard against any mistake in the first entry. The maximum and minimum thermometers should then be set. When set, the end of the mercury in the maximum and the end of the index furthest from the bulb in the minimum should indicate the same temperature as the dry bulb. The door of the screen should finally be closed, after fresh (preferably soft) water has been poured over the wet-bulb thermometer.

*Sling Thermometer.*—Under the name of *thermomètre fronde* (sling thermometer) the French meteorologist M. Arago, in 1830, devised a method of measuring air temperature by means of a thermometer attached to a string, and allowed to swing rapidly round for the space of half a minute or so. By this method the use of a screen is dispensed with, and *even in full sunshine* a close approximation to the true air temperature in the shade may be obtained. This method is, of course, applicable only for isolated observations.

4. *Self-recording thermometers*, or *thermographs*, are so arranged as to record their own readings, independently of the observer, either at frequent intervals in the case of the electrical thermograph, or continuously, as in the photographic thermograph.

In most thermographs the thermometer consists of a slightly curved metal tube filled with spirit (Bourbon tube). One end of this is fixed rigidly to the instrument, while the other is attached to the system of levers which actuates the recording pen.



In the electrical thermographs designed by Dr. Theorell, of Upsala, and Professor F. van Rysselberghe, of Ostend, the thermometer tube is open at the upper end, and a wire is introduced into it, which, by a clockwork mechanism long before devised by Sir Charles Wheatstone, is caused to descend at regular intervals until it touches the surface of the mercury. At the moment of contact an electric current is generated, which causes a needle to prick a paper, on which the thermometer scale is marked, at the point corresponding to the height of the mercurial column at the time. The wire is then raised mechanically, and contact is broken (R. H. Scott). In Sir Charles Wheatstone's thermograph the mercury became oxidised by the electric spark produced at the moment that the dip separated from the mercury (*étincelle de rupture*); but this inconvenience has been obviated.

A photographic thermograph is in use in the stations of the First Order managed by the Meteorological Committee (see p. 28, above). In this instrument a bubble of air is introduced into the column of mercury, and this moves up and down with the temperature, the bore of the tube being larger than in Phillips's maximum thermometer. A lamp is placed before the instrument, and a photograph of the space occupied by the air bubble is continuously taken on prepared paper stretched on a drum, which is caused to revolve on its own axis once in forty-eight hours.

At Greenwich Observatory a thermograph of a rather different construction is employed. It is made somewhat on the principle of the Kew Ba ograph. The light is allowed to pass through the thermometer tube above the level of the mercury on to the sensitised paper. We in this way get a continuous photographic tracing which corresponds along its lower edge with the temperature range, the level of the mercury abruptly cutting off the photographic tracing below.

5. *Radiation Thermometers.*—The subject of radiation is so important that we shall consider it in the next chapter, and there explain the instruments by which it is measured.

Having taken observations with the thermometers already described, we are in a position to ascertain the Mean Tempera-

ture, or that temperature which has an intermediate value—(1) between the several successive hourly temperatures recorded by a thermograph or read by an observer every hour throughout an entire solar day of twenty-four hours; or (2) between the extreme readings recorded in that time; or (3) between the dry-bulb readings taken twice or thrice daily, at 9 a.m. and 9 p.m., as at all British Stations of the Second Order (Normal Climatological Stations); or at 7 a.m., 1 p.m., and 9 p.m., as in Russia; or at 6 a.m., 2 p.m., and 10 p.m., as in Austria.

These are the three methods adopted for ascertaining what is known as mean temperature of a *day*. The mean temperature of a *month* is obtained by dividing the figure 31, or 30, or 29, or 28, as the case may be, into the sum of that number of daily values. The mean temperature of a year is similarly obtained by dividing the figure 12 into the sum of that number of monthly values.

The term *average mean temperature* is properly applied to that temperature which represents the mean of a number of means. For example, in Dublin the mean temperature of March, 1909, was 40·8°, but the average mean temperature for March in that city in a long series of years (1866-1905—that is, forty years) was 43·4°. We say, then, that the mean temperature of March, 1909, was 2·6° below the average.

When dealing with diurnal extremes of temperature, a sufficient approximation to the mean temperature is obtained by taking the arithmetical mean of the maximum and minimum thermometer readings, according to the formula—

$$\text{Min.} + \{\text{Max.} - \text{Min.}\} \times 0.5 = \text{M.T.}$$

A careful comparison, however, with the results yielded by thermograms, as the tracings taken by the thermograph are called, has suggested the following empirical formula, in which the coefficient *C*, a variable quantity from month to month, takes the place of the constant coefficient 0·5.

$$\text{Min.} + \{\text{Max.} - \text{Min.}\} \times C = \text{M.T.}$$

The annexed table gives the coefficients for the different months.

TABLE IV.

Months.				Coefficient.
January	}	..	..	0·520
December				
February	}	..	..	0·500
November				
March	}	..	..	0·485
October				
April	}	..	..	0·476
September				
May	}	..	..	0·470
August				
June	}	..	..	0·465
July				

In accordance with this table, the mean temperature of May, 1909, in Dublin, was

not—

$$\text{Min.} + \{\text{Max.} - \text{Min.}\} \times 0\cdot5,$$

but—

$$\text{Min.} + \{\text{Max.} - \text{Min.}\} \times 0\cdot470.$$

Interpolating the actual values we have

not—

$$45\cdot1^{\circ} + \{60\cdot1^{\circ} - 45\cdot1^{\circ} \times 0\cdot50\} = 52\cdot6^{\circ},$$

but—

$$45\cdot1^{\circ} + \{60\cdot1^{\circ} - 45\cdot1^{\circ} \times 0\cdot470\} = 52\cdot2^{\circ}.$$

## CHAPTER IX

### RADIATION

HEAT is communicated or transmitted from body to body or from place to place, in at least three different ways—by *conduction*, by *convection*, and by *radiation*.

Conduction is the transmission of heat through a conductor, or a substance or body capable of being a medium for its transmission—for example, an iron poker, as contrasted with a stick, which latter is a non-conductor. To quote the *American Cyclopædia* : “ The communication of heat from one body to another when they are in contact, or through a homogeneous body from particle to particle, constitutes conduction.” As a rule, conductors of heat are also conductors of electricity.

In practical meteorology we have illustrations of conduction of heat in the propagation of changes of temperature from the surface of the earth to the successive strata of the subsoil ; and in the alternate heating and chilling of the lowest strata of the air through contact with the ground. The subsoil temperature is recorded by means of underground thermometers, such as are figured in the accompanying illustrations (Figs. 9 and 10).

Convection is the transference or transmission of heat by means of currents generated in liquids and gases by changes of temperature and other causes. When a spirit lamp is applied to the bottom of a vessel of water, the heated water at the bottom expands, becomes specifically lighter, and so rises to the surface, carrying with it or *conveying* the heat it has received. Thus, by convection, heat is diffused at last through the whole mass of the water in the vessel. A similar experiment on a stupendous scale in Nature causes hot and cold winds in the atmosphere, as well as vast ocean currents in the Atlantic and Pacific, which



convey heat or warmth to high latitudes along the north-western coasts of Europe and of America. Convection, like conduction, applies to heat and electricity alike.

Radiation is the transmission from a point or surface of rays of heat along divergent lines (Latin, *radius*, a semi-diameter of a circle; hence a beam or ray of light proceeding from a bright object along divergent right lines or *radii*), not from

particle to particle of the same body (as in conduction), but from one body to another, through air, or vacuum, or space. Radiant heat is, in fact, identical with light, only the wavelengths of the rays of which it consists are at moderate temperatures longer than those corresponding to red light, and so they do not present the phenomena of light. If, however, the temperature of a body is increased, it begins to glow with a dull red light, which passes through shades of yellow, violet, and blue, until an intensely heated body is said to be incandescent, which means that it gives off a light as white as that of the sun, and which contains in their proper proportions all the colours of sunlight.



FIG. 9.—UNDERGROUND THERMOMETER.



FIG. 10.—UNDERGROUND THERMOMETER.

Radiant heat, then, spreads along straight lines, diverging in all directions from the source of heat. "Its intensity," says

Dr. Alex. Buchan,<sup>1</sup> "is proportioned to the temperature of the source, is inversely as the square of the distance from the source, and is greater according to the degree of inclination of the surface on which the rays fall."

Heat is radiated towards the earth from the fixed stars, the planets, the moon, but, above all, the sun. Indeed, for all practical meteorological purposes we may assume that the sun's rays are the only source whence heat reaches the earth's surface. We speak, therefore, of solar radiation alone in connection with the receipt of heat by the earth.

In a paper on the "Conservation of Solar Energy," read before the Royal Society on March 2, 1882, Dr. C. William Siemens, D.C.L., F.R.S., observed: "The amount of heat radiated from the sun has been approximately computed by the aid of the pyrheliometer of Pouillet, and by the actinometers of Herschel and others, at 18,000,000 of heat units from every square foot of its surface per hour, or, put popularly, as equal to the heat that would be produced by the perfect combustion every thirty-six hours of a mass of coal, of specific gravity = 1.5, as great as that of our earth.

"If the sun were surrounded by a solid sphere of a radius equal to the mean distance of the sun from the earth (95,000,000 of miles), the whole of this prodigious amount of heat would be intercepted; but considering that the earth's apparent diameter, as seen from the sun, is only seventeen seconds, the earth can intercept only the 2,250 millionth part."

In accordance with physical laws, no sooner does the earth receive heat from the sun than it begins to radiate it back again into space in all directions. Hence we speak of *terrestrial radiation*.

From what has been stated above in a quotation from Dr. Buchan, it is clear that solar radiation is much less in winter than in summer, owing to increased inclination; but it is also less in July than in December (taking the earth as a whole), because in the latter month the sun and the earth are some 3,000,000 of miles nearer to each other than in the former. According to Dr. R. H. Scott, F.R.S., with the existing value of the eccen-

<sup>1</sup> *Introductory Text-Book of Meteorology*, p. 48. William Blackwood and Sons: Edinburgh and London. 1871.

tricity of the earth's orbit, the amount of heat received in perihelion (the southern summer) is to that received in aphelion (the northern summer) as 1.034 is to 0.967.

Solar radiation is also interfered with by clouds, but is not materially affected by the air through which it passes, nor is it diverted from a straight course by the wind (Buchan).

Terrestrial radiation tends to dissipate into space the heat which the earth has received from the sun, and as a consequence temperature falls in winter, when the slanting rays of the sun pour down less upon the earth's surface. Again, not only the seasonal, but also the diurnal, range of temperature depends on radiation. By day, solar radiation predominates and temperature rises; by night, solar radiation ceases while terrestrial radiation continues, and so temperature falls. Just as solar radiation is interfered with by clouds, so an overcast sky interrupts terrestrial radiation. Hence dew is not deposited on a cloudy night, because the thermometer does not fall below the temperature of saturation, or the dew-point. But even an excess of moisture in the atmosphere interferes with terrestrial radiation, so that very low temperatures are never felt in damp weather, while severe frosts occur in spring nights, when the air is very dry and the sky is often clear.

A covering of snow at one and the same time prevents and facilitates radiation. The explanation of this paradox is that the snow acts like a cloud canopy, and interferes with radiation from the surface of the ground, which is in this way kept warm. But, further, snow is a bad conductor of heat, and so the warmth is imprisoned beneath it through non-conduction. Hence the surface of the snow becomes intensely cold, for no heat reaches it from below, while it radiates freely into space what heat it does already possess.

Dr. Hann<sup>1</sup> calculated that in a vertical column of absolutely dry air the thermometer should fall 1° F. for every 182 feet of altitude, or 1° C. for every 100 metres. In nature, however, there is practically no such thing as absolutely dry air. The moisture in the atmosphere, then, is liable to be condensed as the temperature falls with increasing altitude. But in the process

<sup>1</sup> *Allgemeine Erdkunde*. Third edition. Tempsky: Prague. 1881.

of condensation latent heat is set free in large quantities with the effect of lessening the rate of cooling in the vertical column of air. Sir John Herschel long ago calculated that the slower rate of cooling amounted to about  $1^{\circ}$  F. for every 300 feet of vertical height, and this value is generally accepted. It is, however, necessary to explain that sometimes in winter conditions of temperature are actually reversed, and an "upbank thaw," as it is called, may occur on mountains with the arrival on their slopes of a warm air current, while the cold, dense air in the valleys and plains below may cause unbroken frosts at lower levels. Recent observations on the upper air by balloons and kites go to show that inversion of temperature is a very common phenomenon, particularly in winter. By the term is meant that a stratum of warmer air may be superimposed upon one of colder air nearer the earth's surface.

Further, the descent of temperature with increasing altitude does not go on indefinitely. Within the first two miles from the ground the temperature variations are very complex—there is often "inversion." Above the two-mile limit a very nearly uniform rate of fall of temperature is observed until what is called the "isothermal layer" of the atmosphere is reached, at from six to eight miles above the earth's surface (12 kilometres, or nearly  $7\frac{1}{2}$  miles). This question will be discussed later on (see p. 325).

In estimating the influence of radiation upon climate, it is to be borne in mind that the specific heat of water is much higher than that of land—in the proportion of about four to one. Hence solar radiation heats water much more slowly than it heats dry land, and, again, water cools in turn much more slowly than dry land does. In these facts we recognise one explanation of the modifying and mollifying effects of the ocean upon climate. Its presence controls temperature, forbidding it to rise quickly in summer or to fall quickly in winter. Of course, by convection also, currents of cool water flow towards warm regions, and currents of warm water towards cold regions.

We are now in a position to resume the description of various thermometers employed in meteorological observations, which was begun in the preceding chapter.



5. *Radiation Thermometers.*—*Solar radiation* is measured by the black-bulb thermometer *in vacuo*, an instrument which was first suggested by Sir John Herschel. The late Rev. Fenwick W. Stow, M.A., of Aysgarth Vicarage, Bedale, Yorkshire, described this instrument as follows: The insulated solar maximum thermometer, usually called the black bulb *in vacuo*, is a sensitive maximum thermometer, having the bulb and a given portion of the stem covered with lamp-black, the whole being enclosed in a glass tube from which all air and moisture have been removed, so that the heat of the sun's rays is thus obtained, apart from the influence of vapour or passing currents of air. The stem near the bulb must be blackened to prevent reduction of temperature in the bulb through conduction, the bright stem chilled by radiation in this way affecting the bulb. This delicate instrument should be placed on a stand 4 feet above the ground, in an open space, with its bulb directed towards the south-east, and free from contact with any substance whatever.

The Royal Meteorological Society recommends the use, in addition to the black bulb, of a bright-bulb thermometer *in vacuo*. The readings of this latter instrument will, of course, be lower than those of the black bulb, because the bright bulb will radiate freely the heat which it receives from the sun's rays. Fig. 11 represents these thermometers *in situ*.

The black-bulb and bright-bulb thermometers *in vacuo* should be tested *in sunshine* at Kew Observatory *after* enclosure in their vacuum jackets. The corrections usually given on the Kew certificate apply merely to the instruments before they are enclosed in the outer jacket.

The *helio-pyrometer*, arranged by Mr. T. Southall, of Birming-

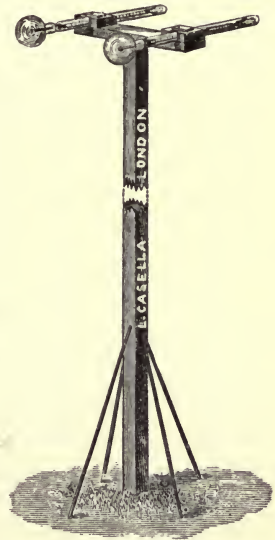

FIG. 11.—SOLAR RADIATION THERMOMETER STAND.

ham, gives extraordinary readings at times ( $216^{\circ}$ ,  $217^{\circ}$ , and even  $231.5^{\circ}$  in July, 1859), and these readings are confirmed by water being caused to boil violently in a small vessel attached to the apparatus. One of Casella's solar radiation maximum thermometers, made on Professor Phillips's principle, is fixed on a cushion at the bottom of a box, the sides of which are also cushioned, and a thick piece of plate glass is laid upon the top to prevent currents of air carrying off the heat as well as with the view of preventing the cooling effects of terrestrial radiation. The box is placed in such a position that the sun's rays may fall as nearly as possible perpendicularly on the glass. A change of position to secure this end may be required twice or three times a day. No doubt a portion of the sun's heat is lost by reflection from the surface of the plate-glass cover, but the amount of the loss can be calculated.

Other instruments for measuring the intensity of solar radiation which deserve mention are: Sir John Herschel's actinometer (Greek, ἀκτίς, a ray; μέτρον, a measure), Padre Secchi's solar intensity apparatus, and Pouillet's pyrheliometer (Greek, πῦρ, fire or heat; ἥλιος, the sun; μέτρον, a measure). By means of this last instrument the effect of the sun's heat upon a given area is ascertained by the number of degrees of heat imparted to a given quantity of mercury in five minutes.

At the International Meteorological Conference held at Innsbruck in September, 1905, Ångström's electric compensation pyrheliometer and actinometer were recognised as satisfactory instruments for absolute actinometric measurements. In connection with a report on actinometry by M. Violle, the Conference resolved that measurements of the total solar radiation be made at central observatories, and at other stations which possess the facilities to do so, regularly each day at 11 a.m., or from 11 a.m. to 1 p.m. Ångström's compensation pyrheliometer should be used exclusively for these measurements, as well as for measurements of terrestrial radiation to be made each evening at 10 p.m., or from 10 p.m. to midnight.

The Richard system for recording solar heat (actinometer) is partly based upon researches made by Professor Violle, and is represented in Fig. 12. Two thermometers, the bulb of one

of which is bright, while that of the other is a dull black, are protected by glass spheres and record on a single sheet, so that the difference of their readings, and also the times of their respective maxima, can be easily seen.

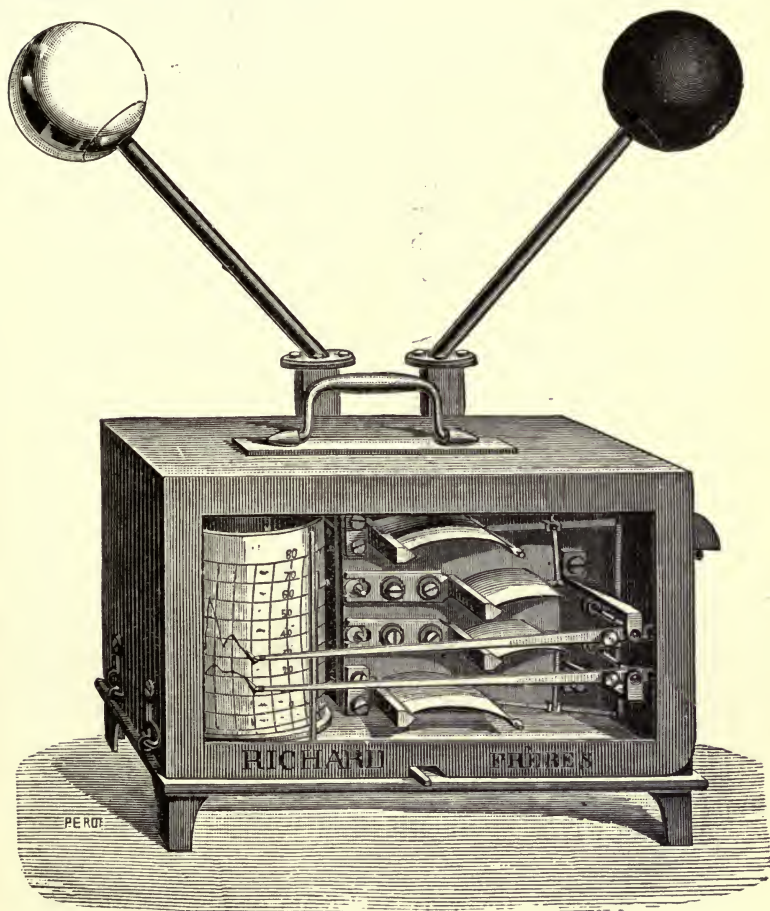

FIG. 12.—RICHARD'S ACTINOMETER.

When using the black bulb *in vacuo*, observations should also be made with the ordinary maximum thermometer in the shade. The greatest amount of radiation during the day will then be

approximately indicated by subtracting the maximal temperature in the shade from the maximal reading recorded by the solar radiation thermometer. The difference may usually be regarded as an index of the intensity of solar radiation.

*The Wilson Radio-Integrator.*—The late Dr. W. E. Wilson, F.R.S., of Daramona, Streete, Co. Westmeath, shortly before his death designed an ingenious instrument for recording the total amount of solar radiation daily received by the ground. The general form of the instrument is shown in the accompanying illustration (Fig. 13). The radio-integrator, as it is called, consists of a sort of sealed retort for the distillation of a volatile liquid, presumably *in vacuo*, by the heat of the sun. When set for an observation, the whole of the liquid is in the upper bulb,

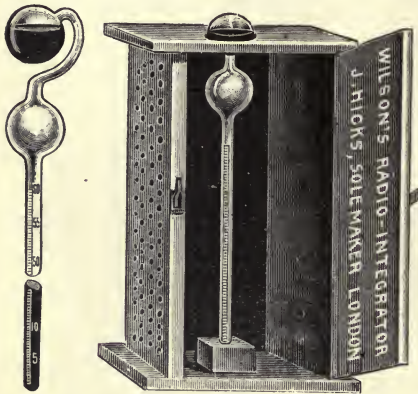

FIG. 13.—WILSON'S PATENT RADIO-INTEGRATOR.

which is exposed to the sun, while the lower bulb and tube are sheltered in a white-painted perforated box. The liquid as it evaporates is condensed in the lower bulb, and trickles down into the tube, which is graduated according to an arbitrary scale. The amount of liquid evaporated in the previous twenty-four hours is read daily at 9 a.m., and recorded in

terms of the divisions engraved on the glass tube. This instrument has been in use by Dr. H. R. Mill at Camden Square, London, since July, 1907.

*Terrestrial Radiation.*—The thermometer used for registering this meteorological factor is a delicate self-registering spirit minimum thermometer, of Rutherford's construction, which is enclosed in a glass cylinder for protection. To increase the sensitiveness of the spirit "grass minimum," Mr. Casella designed a thermometer in which the bulb, being extended in a forked form exposes a greatly increased surface to the air (Fig. 14). In this



way the instrument is rendered little, if at all, less sensitive than Mr. Casella's mercurial minimum already described.

A thermometer intended to measure terrestrial radiation should be suspended over a piece of smooth lawn grass on wooden



FIG. 14.—CASELLA'S BIFURCATED GRASS MINIMUM.

props shaped like Y's, at a height of only 3 inches or so, in order to escape the disturbing influence of the wind. The amount of terrestrial radiation is determined by subtracting from the minimal temperature recorded in the thermometer screen the minimum registered on the grass. Should the ground be covered with snow, the radiation thermometer should be laid upon the surface of the snow. Where a grass plot is not available, the thermometer should be placed on a large black board laid upon the ground.

*Earth Temperatures.*—In connection with radiation it is desirable to ascertain the temperature of the soil at fixed depths. This may best be done by using Symons's earth thermometer (Fig. 15).<sup>1</sup> It is a sluggish thermometer mounted on a short weighted stick attached to a strong chain. It is lowered by means of this chain into a long, stout, iron pipe, pointed at the lower end, and driven into the earth to any required depth—1 foot, 2 feet, 3 feet, or 4 feet below the surface. The top of the iron pipe or tube is closed by a tight-fitting iron cap. The tube should be driven into the soil below short grass, and in a well-exposed situation.

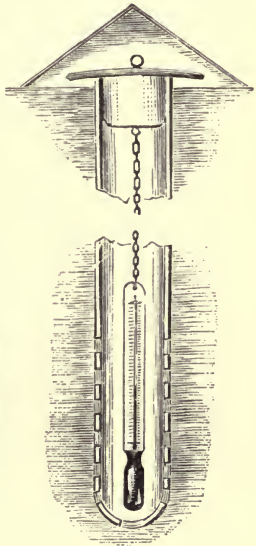

FIG. 15.—SYMONS'S EARTH THERMOMETER.

Mr. Casella also has designed a self-registering thermometer

<sup>1</sup> "Improved Form of Thermometer for observing Earth Temperature," By G. J. Symons, F.M.S. *Quarterly Journal of the Meteorological Society*, vol. iii., p. 421, 1877.

for immersion to any depth in the earth or wells, where it will record the maximum and minimum temperatures for a required interval of time.

From observations at the Calton Hill, Edinburgh, Principal Forbes concludes that the seasonal variations of temperature are reversed at a depth of 24 feet—the greatest warmth occurring at that depth about January 4, and the greatest cold about July 13. Below 40 feet there is no annual variation in the temperature of the soil.

The temperature of the soil, as shown by the earth thermometer, has a vital bearing on public health. Systematic observations at the City Meteorological Observatory, 299, Oldham Road, Manchester, convinced Dr. John Tatham, formerly the able Medical Officer of Health for that great city, and more recently Medical Superintendent of Statistics at Somerset House, that, in accordance with the views of Dr. Edward Ballard, F.R.S., when the earth-temperature at the depth of 4 feet from the surface rises to 56° F. infantile diarrhœa may be expected to become epidemic in the city. Dr. Ballard's proposition was that the temperature of the soil is a far more effective element in raising the death-rate from diarrhœal diseases than any other meteorological factor. He constructed for London and many other towns in the Kingdom a large number of charts showing week by week for many years the earth-temperature at a depth of 1 foot from the surface and at a depth of 4 feet also, each chart showing in addition the diarrhœal mortality of the corresponding weeks.<sup>1</sup>

The general result shown by these charts is as follows :

1. The summer rise of diarrhœal mortality does not commence until the mean temperature recorded by the 4-foot earth thermometer has attained somewhere about 56° F., no matter what may have been the temperature previously attained by the atmosphere or recorded by the 1-foot earth thermometer.

2. The maximal diarrhœal mortality of the year is usually observed in the week in which the temperature recorded by the 4-foot earth thermometer attains its mean weekly maximum.

<sup>1</sup> *Supplement in Continuation of the Report of the Medical Officer for 1887. Annual Report of the Local Government Board, 1887-88, p. 1, et seq.* London : Eyre and Spottiswoode. 1889. Quarto.

3. The decline of the diarrhœal mortality coincides with the decline of the temperature recorded by the 4-foot earth thermometer, which temperature *declines* very much more slowly than the atmospheric temperature, or than that recorded by the 1-foot earth thermometer. The epidemic mortality may in consequence continue (although declining) long after the last-mentioned temperatures have fallen greatly, and may extend some way into the fourth quarter of the year.

4. The atmospheric temperature and that of the more superficial layers of the soil exert little, if any, influence on the prevalence of diarrhœa until the temperature recorded by the 4-foot earth thermometer has risen to 56° F. Then their influence is apparent, but it is a subsidiary one, notwithstanding the statement made by Dr. August Hirsch that the summer diarrhœa of children makes its appearance as an epidemic only in those districts whose average temperature for the day in the warm season is rather more than 15° C. (59° F.).

On January 1, 1904, through the liberality of the Provost and Senior Fellows of Trinity College, a Normal Climatological Station was established within the precincts of the University of Dublin. The station, which is under the supervision of Professor W. E. Thrift, M.A., F.T.C.D., occupies an open space in the Fellows' Garden, Trinity College, and is fully equipped. At the suggestion of Dr. William Napier Shaw, F.R.S., Director of the Meteorological Office, London, the equipment included two earth thermometers. One of these has its bulb at a depth of 12 inches (1-foot earth thermometer) below the surface of the ground. The bulb of the other is sunk in a metal tube to a depth of 4 feet.

In a paper read before the State Medicine Section of the Royal Academy of Medicine in Ireland on February 10, 1905, I discussed the question of Earth Temperature and Diarrhœal Diseases in Dublin during 1904. The observer, my son, Arthur Robert Moore, M.A., threw the figures into two diagrams, of which the second is here reproduced. It contains two weekly curves for the whole year 1904. The upper of these represents the weekly march of underground temperature at a depth of 4 feet. The lower curve gives the number of deaths from diarrhœal

diseases registered week by week in 1904 in the Dublin Registration Area.

Reference to the curves in the diagram shows that diarrhœal mortality in the Dublin district in 1904 was trifling till the week ended August 6—that is, the third week after the subsoil temperature at 4 feet had passed above 56° F. The mortality rapidly increased till the week ended August 27, in which thirty-five deaths from diarrhœal diseases were registered, or about 10 per cent. of all the deaths from those diseases in the whole year 1904.

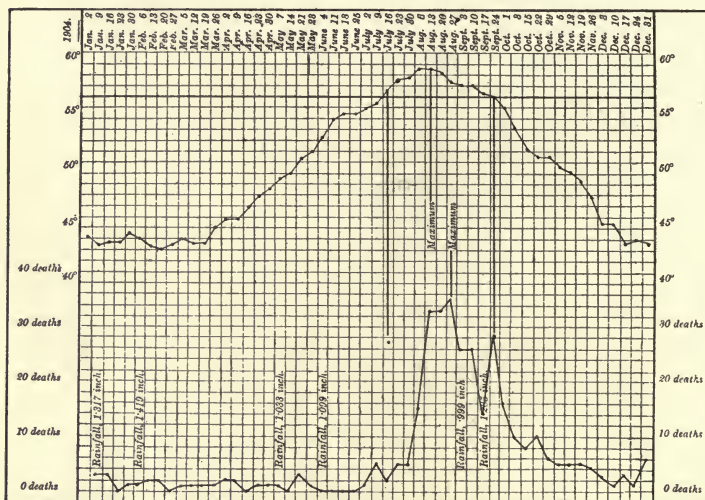

FIG. 16.—ILLUSTRATING THE RELATION BETWEEN UNDERGROUND TEMPERATURE AND THE DEATH-RATE FROM DIARRHŒAL DISEASES.

This maximum of mortality followed the maximum of warmth of the soil at 4 feet (58.5°) by an interval of just a fortnight. Such a coincidence is remarkable. Diarrhœa kills very young children quickly—usually within a week. Then, allowing a few days for delay in registration, we come to the close of the second week.

The diagram also shows that the 4-foot thermometer stood at 56° or upwards from July 10 to September 24—a period of eleven weeks. Starting a similar period of eleven weeks a fortnight later (to allow time for the malady to attack and kill, and for registration of the resulting deaths), we find that in the eleven



weeks beginning July 24 and ending October 8, the diarrhœal deaths were 249, or 71·7 per cent. of the total deaths from diarrhœal diseases registered in 1904, 339 in number. Of these only 18 were registered in the first quarter of the year, only 10 in the second, 243 in the third, and 68 in the fourth quarter.

There can be no doubt that the prevalence of cholera or epidemic summer diarrhœa, the prevalence of enteric fever, and that of cholera are all equally determined by this critical subsoil temperature of 56°, probably not directly, in the way of cause and effect, but indirectly, by promoting the decomposition of human food-stuffs, especially milk, through the agency of flies or other carriers of saprophytic or pathogenic organisms.

*Duration of Bright Sunshine.*—Within the past twenty-five years striking observations have been made on this point under the auspices of the Meteorological Office, London, and of the Royal Meteorological Society and the Scottish Meteorological Society. It is manifest that the amount of solar radiation will depend on the amount of bright sunshine. A remarkable instance of this occurred in the spring of 1893, when the registered amount of bright sunshine was much in excess of the average, and when solar radiation was so powerful as to cause a marvellous blossoming not only of the ordinary spring flowers and shrubs, but also of shrubs which rarely flower in ordinary years in the climate of the British Isles.

The instruments which are used for recording the duration of sunshine are (1) the Campbell-Stokes Burning Recorder; (2) the Whipple-Casella Universal Sunshine Recorder; (3) the Jordan Photographic Recorder. The principle of the first two of these instruments is the same. It consists in burning a tracing in a piece of mill-board placed in the focus of rays from a glass sphere, which acts as a lens when exposed to bright sunshine. The burning recorder was originally devised in 1854 by Mr. John F. Campbell, F.G.S., of Islay, and was improved by Professor Sir George G. Stokes, Bart., F.R.S., of Cambridge.

1. The Campbell-Stokes Sunshine Recorder consists of a sphere of crown glass 4 inches in diameter and 3 pounds in weight, supported on a pedestal in a metal zodiacal frame (Fig. 17). It should be fixed in an open position, so that the

sun's rays may fall upon it at any time between sunrise and sunset. It must face due south, so that the sun's image shall fall upon the meridian line marked on the inside of the ring supporting the recording cards when the sun is itself upon the meridian. The axis of the ring in question must be inclined to the horizon at an angle equal to the latitude of the place, and the instrument must be level as regards east and west.<sup>1</sup> There are three grooves in the ring which supports the card: one holds rectangular cards with hour figures printed upon them suitable for the equinoxes (from March 1 to April 12, and again from September 1 to October 12); one, long curved cards similarly

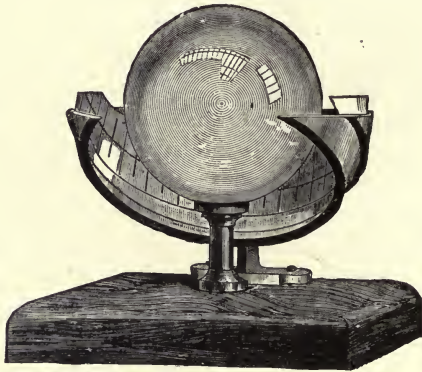

FIG. 17.—THE CAMPBELL-STOKES SUNSHINE RECORDER.

time-marked for summer (from April 13 to August 31); and one, short curved cards for winter (from October 13 to February 28 or 29). A card being fixed in the proper groove according to the season of the year, the sun when shining burns away or chars the surface at the points on which its image falls from moment to moment, and thus a tracing of bright sunshine is given. A card should be removed daily after sunset, and a new one inserted ready for next day. This apparatus costs £9 9s.

2. The Whipple-Casella modification of this instrument has divided latitude and diurnal circles, so that it can be set for any

<sup>1</sup> *Quarterly Journal of the Meteorological Society*, 1880, vol. vi., p. 83. "Description of the Card Supporter for Sunshine Recorders adopted at the Meteorological Office." By Professor George Gabriel Stokes, M.A., F.R.S.

locality and for any day in the year, thus earning its name of "Universal Sunshine Recorder." It is an expensive instrument, costing £15 ; but, owing to its powers of adjustment to time and place, it requires merely a strip of cardboard duly hour-marked instead of Sir George G. Stokes's equinoctial and summer and winter cards (see Fig. 18).

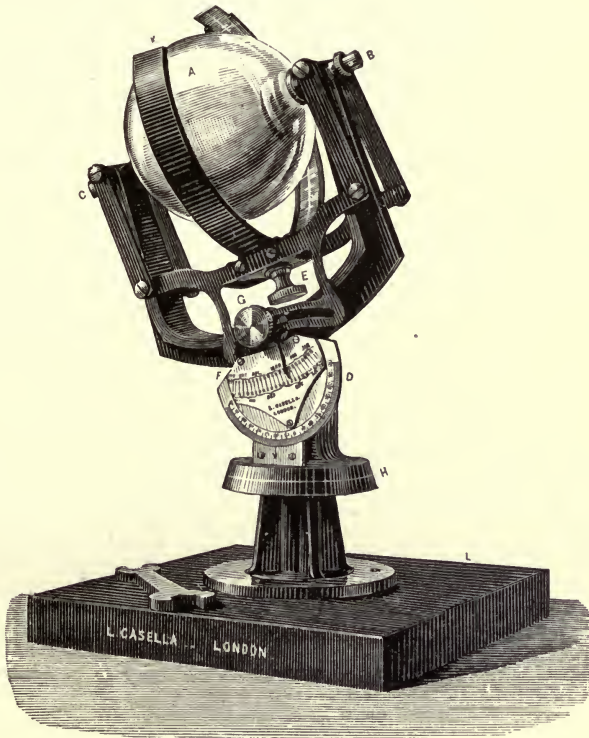

FIG. 18.—THE WHIPPLE-CASELLA UNIVERSAL SUNSHINE RECORDER.

3. In 1838 an automatic Daylight or Sunlight Recorder was invented and constructed by Mr. T. B. Jordan, who wrote and published an account of his invention in the *Sixth Annual Report of the Royal Cornwall Polytechnic Society* (p. 185). The instrument, however, which now goes by the name of the "Jordan Photographic Sunshine Recorder," was designed in 1885 by Mr. James B.

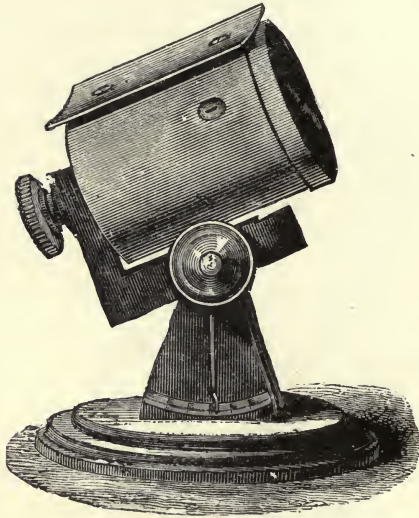

FIG. 19.—JORDAN PHOTOGRAPHIC SUNSHINE RECORDER.

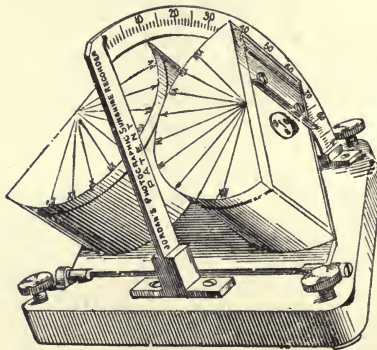

FIG. 20.—IMPROVED JORDAN PHOTOGRAPHIC SUNSHINE RECORDER.

Jordan, of the Home Office.<sup>1</sup> Two forms of the Jordan Photographic Sunshine Recorder are in use. The first pattern, represented in Fig. 19, brought out in 1885, consists of a cylindrical box, on the inside of which a sheet of sensitive cyanotype paper is carefully placed day by day. The sunlight is admitted

<sup>1</sup> *Quarterly Journal of the Royal Meteorological Society*, 1886, vol. xii., p. 23.



into the box by two small apertures, and acts on the paper chemically, leaving a tracing as the ray travels across it owing to the earth's rotation. The improved pattern—Jordan's twin-cylinder recorder—(Fig. 20) has two semi-cylindrical boxes, one to hold the forenoon, the other the afternoon, prepared charts of sensitised paper. A slit, through which the beam of sunlight finds entrance, is placed in the centre of the rectangular side of each box, so that the length of the beam within the chamber is the radius of the cylindrical surface on which it is projected. The path of the sunbeam, therefore, follows a straight line on the sensitive paper at all seasons. The instrument must be carefully adjusted to the meridian and to the latitude of the place, and must be firmly fixed (William Marriott, F.R.Met.Soc.).

The sunshine recorded by any of these instruments should be measured in hours and tenths of an hour, and not in minutes. A "sunless day" is that on which the record of bright sunshine is less than three minutes.

## CHAPTER X

### ATMOSPHERIC PRESSURE

WE have already seen in Chapter II. that the atmosphere has weight, and can be weighed. The instrument by which this is effected is called the barometer (Greek, *βάρος*, *weight*; *μέτρον*, *a measure*). But it would be most misleading to suppose that the only use of the barometer is the mere weighing of the atmosphere. By a careful study of the properties of this marvellous instrument we are enabled to measure the heights of mountains, to ascertain the distribution of atmospheric pressure over the earth's surface by sea as well as by land, and at the different seasons of the year; to understand in consequence the prevalent winds at all times and in all places, to trace the ever-shifting distribution of atmospheric pressure over vast districts, and finally, to "forecast" the weather. This may be done either by a consideration of barometrical observations taken at a single station, or by means of telegraphic information as to a number of such observations taken synchronously (or at the same moment of time) at many stations scattered over a large area, like the west, north-west, and centre of Europe, or the United States of America and Canada.

Surely such far-reaching potentialities as those now indicated bespeak for so wonderful an instrument our liveliest interest and most attentive study.

An observation of Galileo Galilei, of Pisa, the father of experimental science, that water would not rise in a pump more than "eighteen cubits" (*diciotto braccia*) above the level of a well, led to the discovery of the pressure of the atmosphere by Evangelista Torricelli, his pupil and successor in the Chair of Philosophy and Mathematics at Florence, who also devised the means of measuring that pressure. Torricelli's famous experiment was made in 1643

He was testing Galileo's dictum that "Nature abhors a vacuum" (up to 32 feet, in the case of water), and for convenience employed mercury. By doing so, he found that Nature's abhorrence of a vacuum varied for different fluids. Torricelli filled a tube (Fig. 21, C—D) 3 feet long with mercury, and then inverted it and plunged its lower end into a basin filled half with mercury and half with water. So long as the lower end of the tube

remained below the level of the mercury in the basin, the height of the column of mercury in the tube proved to be about 30 inches, and a vacant space of 6 inches was left at the top of the tube—a space which afterwards came to be, and is still, known as the *Torricellian vacuum* (Fig. 21, A—B). The moment, however, that the lower end of the tube was raised above the surface of the mercury in the basin into the overlying stratum of water, all the mercury in the tube rushed out, its place being taken by the water, which equally readily rushed in and *filled the tube completely*. Reasoning out the matter, the philosopher concluded that some one force existed which was able to support

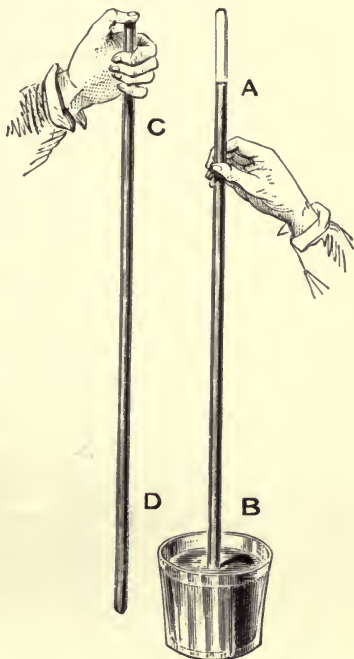

FIG. 21.—TORRICELLI'S EXPERIMENT.

a column of mercury to a height of 30 inches in the tube, but a column of water to a much greater height. This force could be none other than the pressure of the atmosphere on the open surface of the fluids—mercury and water—in the basin. Thus was the barometer discovered.

Torricelli further proved that Nature's abhorrence of a vacuum was represented by a column of fluid inversely proportional to its specific gravity. Take the very fluids under consideration—

water and mercury ; the specific gravity of water being 1, that of mercury is 13·594—and we get this inverse proportion :

1 : 13·594 :: 30 inches : x = the required height of a column of water supported by the atmosphere.

$$13·594 \times 30 \text{ inches} = 407·82 \text{ inches} = 33·99 \text{ feet.}$$

This principle has been taken advantage of in selecting fluids for the construction of a barometer. Thus mercury is one of the handiest, because, in addition to other recommendations, it requires a tube only 32 inches long in consequence of its high specific gravity. On the other hand, if we could use water in an immense tube 35 or 36 feet in length, the smallest variations in atmospheric pressure could easily be observed. Water, however, is not available because of its high freezing-point. Hence we select glycerine, the specific gravity of which is 1·26, and which, while undiluted, does not freeze at any known terrestrial temperature (a 50 per cent. solution freezes at  $-31^{\circ}$  C., or  $-23·8^{\circ}$  F.). In practice we find that a column of glycerine 27 or 28 feet high will yield most valuable barometrical indications. The proportional statement is :

1·26 : 1 :: 33·99 feet : x = the required height of the column of glycerine in feet or inches—

$$1·26)33·99(26·976 \text{ feet, or } 323·7 \text{ inches.}$$

$$\begin{array}{r} 252 \\ \hline 879 \\ 756 \\ \hline 1230 \\ 1134 \\ \hline 960 \\ 882 \\ \hline 780 \\ 756 \\ \hline 24 \end{array}$$

The proportional statement between glycerine and mercury works out as follows :

1·26 : 13·594 :: 30 inches : x = the required height of the column of glycerine in inches or feet—

$$1·26)13·594 \times 30, \text{ i.e., } 407·82(323·66 \text{ inches} = 323·7 \text{ inches, } \textit{quam proxime} \\ = 26·975 \text{ feet.}$$

$$\begin{array}{r} 378 \\ \hline 298 \\ 252 \\ \hline 462 \\ 378 \\ \hline 840 \\ 756 \\ \hline 84 \end{array}$$



Jordan's glycerine barometer, used at the *Times* office, London, consists of a gas tube,  $\frac{5}{8}$  inch in diameter and 28 feet in height. As glycerine has a singular affinity for water, the glycerine in the cistern of this gigantic barometer is covered with a layer of paraffin-oil.

The advantage of the glycerine barometer, then, is that it magnifies tenfold, as it were, the readings of the mercurial barometer—323.7 inches on the scale of the glycerine barometer corresponding to 30 inches on that of the mercurial barometer.

THE TIMES OFFICE, 2 A.M.  
 READINGS OF THE JORDAN BAROMETER (CORRECTED)  
 DURING THE PAST TWENTY-FOUR HOURS.  
 FEBRUARY 26—27.

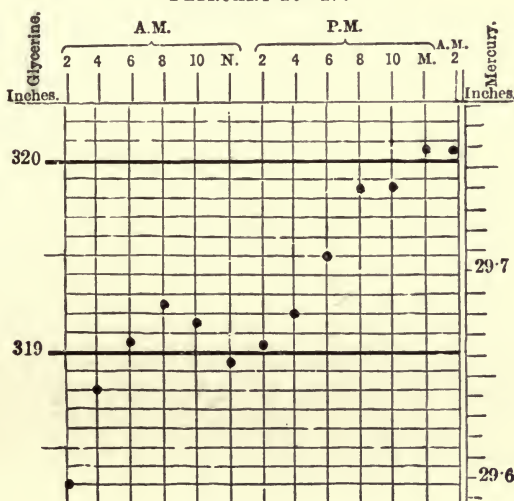

FIG. 22.

Another interesting application of the principle that the heights of columns of liquids or gases are inversely proportional to their specific gravities is the attempt to determine the height of the atmosphere. As air is about 10,000 times lighter than mercury, the height of the atmosphere should on this principle be 10,000 times 30 inches, or 300,000 inches—that is, 4.7 miles. In Chapter II., however, it has been shown that the density of the aerial column lessens according to its height, and so, as a matter

of fact, the height of the atmosphere is vastly greater than 4·7 miles—an altitude which falls short of the highest peak of the Himalayas by 4,000 feet.

Torricelli's surmises received their full confirmation at the hands of the French philosopher, Blaise Pascal, of Clermont, in Auvergne. In 1647 he was in Paris, when the thought struck him that if the Torricellian theory of atmospheric pressure was correct, the height of the column of mercury supported by the air should be less on the top than at the foot of a mountain. He accordingly wrote to his brother-in-law, Perrier, who lived at Clermont, to request him to ascend the neighbouring Puy de Dôme, with the Torricellian tube in his hands. It was not until September 19, 1648, that Perrier was able to carry out the long-projected experiment. In the presence of a distinguished company of savants in Clermont he on that day repeatedly performed the Torricellian experiment. The party then ascended the mountain, which at a distance of eight miles rises some 3,510 feet above Clermont, and, to Perrier's surprise, and ultimately to Pascal's delight, the mercury was found to stand 3·33 inches lower on the summit than at Clermont. On the way down, at Font de l'Arbre, the column was proved to have an intermediate height. Perrier's observations on this memorable day gave 3,458 feet for the height of the Puy de Dôme above Clermont, and the actual height is now stated to be 3,511 feet. The account of this experiment was given by Blaise Pascal himself in a pamphlet published in Paris in 1648, and entitled "Récit de la grande Expérience de l'Equilibre des Liqueurs."<sup>1</sup>

During the years 1649-50 readings of the "Torricellian column," as it was called, were taken daily, and, at the same time, by Pascal at Paris, Perrier at Clermont, and Chanut and Descartes at Stockholm, "in order to see if anything could be discovered by confronting them with one another." Mr. Richard Strachan, F.R.Met.Soc., who gives much of the foregoing information in a lecture delivered under the auspices of the Meteorological Society in 1878,<sup>2</sup> observes: "Pascal was thus the pioneer of the

<sup>1</sup> *Neudrucke von Schriften und Karten über Meteorologie und Erdmagnetismus*. Herausgegeben von Professor Dr. G. Hellmann. 4to. Berlin: A. Ascher and Co. 1893.

<sup>2</sup> *Modern Meteorology*, p. 70 et seq. London: Edward Stanford. 1879.

synchronous observations upon which modern storm-warnings depend.”

In 1665 the Hon. Robert Boyle observed the Torricellian column in relation to weather, and gave it a scale and lettering. In the same year Robert Hooke invented the “weather glass,” or wheel barometer.

In the *Philosophical Transactions* for 1666, p. 153, we read that “Modern Philosophers, to avoid Circumlocutions, call that Instrument, wherein a Cylinder of Quicksilver, of between 28 and 31 inches in Altitude, is kept suspended after the manner of the Torricellian Experiment, a Barometer or Baroscope<sup>1</sup> . . . to detect all the minute variations in the Pressure and weight of the air.”

A very full historical account of the barometer was communicated to the Royal Meteorological Society on March 17, 1886, by the President, Mr. William Ellis, F.R.A.S., of the Royal Observatory, Greenwich. His Presidential Address will be found in the twelfth volume of the *Quarterly Journal of the Royal Meteorological Society* (No. 59, July 1886, p. 131).

<sup>1</sup> Greek, βάρος, *weight*; σκοπέω, *I inspect*.

## CHAPTER XI

### THE BAROMETER

THE most usual form of barometer is a glass tube, about 34 inches in length, closed at one end and carefully filled with pure mercury of the specific gravity of 13·594. If necessary, the mercury in the tube should be boiled to expel all air. The tube is then placed vertically, with its open end dipping into a cup of mercury called the "cistern." When so placed the mercury falls in the tube at sea-level to 30 inches, or some point not very much above or below that level, according to the pressure of the atmosphere at the time.

In Dublin the monthly mean atmospheric pressure rises to 29·994 inches in June, and falls to 29·863 inches in December. The absolute extreme readings of the barometer at any time taken by me were : maximum, 31·020 inches, at 10 a.m. of January 9, 1896 ; minimum, 27·758 inches, at 2.30 p.m. of December 8, 1886. These readings assuredly represent the extreme range of atmospheric pressure, reduced to 32° F., and to mean sea-level, in Dublin—namely, 3·262 inches, rather more than  $3\frac{1}{4}$  inches.

Incidentally, I may mention that, in the depression of December 8, 1886, Armagh Observatory recorded a minimum of 27·446 inches at 1 p.m., while at 6 p.m. the barometer read only 27·41 inches at Barrow-in-Furness.

On the other hand, at 6 p.m. of January 22, 1907, the barometer read 31·58 inches at Riga, and at 8 a.m. of the following day the isobar of 31 inches stretched westward to Ulster, the barometer reading 31·01 inches at Donaghadee. Also, on January 31, 1902, the barometer rose to 31·118 inches at Aberdeen ; and on January 28, 1905, atmospheric pressure reached, or slightly exceeded, 31 inches all over the southern half of Ireland. Roche's



Point, Cork Harbour, reported 31·03 inches both morning and evening of the 28th, and at 6 p.m. the reading was 31·06 inches at St. Mary's, Scilly Isles. On that same day at 9 p.m. the reading of 31·007 inches was recorded in Trinity College, and that of 30·999 inches at Fitzwilliam Square, Dublin. But these values by no means represent the extreme range of the barometer. On January 26, 1884, the barometer fell to 27·332 inches at Ochertyre, near Crieff, in Perthshire, and on February 5, 1870, the reading of 27·33 inches was recorded on board the Cunard steamer *Tarifa* in the North Atlantic, in lat. 51° N. and long. 24° W. But even these extremes, all reduced to 32° and mean sea-level, have been exceeded. In a communication to *Nature*, dated January 6, 1887 (vol. xxxv., p. 344), Mr. Blanford states that "the cyclone which on the morning of September 22, 1885, swept over False Point, on the coast of Orissa, gave the lower readings 27·135 inches at the beginning of the central calm, and 27·154 inches half an hour later (both readings reduced to 32° and sea-level)." These readings were made by a verified standard barometer, and are thoroughly authentic. For comparison with English standards a further subtractive correction of ·011 inch has to be applied, which would make the lowest reading 27·124 inches.

In an interesting paper<sup>1</sup> on "The Storm and Low Barometer of December 8 and 9, 1886," Mr. Charles Harding, F.R.Met.Soc., quotes from Professor Loomis's *Contributions to Meteorology*, chap. ii., a reading of 31·72 inches, reduced to sea-level, observed at Semipalatinsk, in Western Siberia (lat. 50° 24' N., long. 80° 13' E.) on December 16, 1877, the reading at Barnaul being 31·63 inches at the same time. This gives a difference from Mr. Blanford's reading, 27·12 inches, of +4·6 inches, which is probably the maximal range of the barometer ever observed at the earth's surface (reduced to sea-level).

These extreme readings, although rarely observed, should be provided for in the scaling of a barometer, which should range from 32 inches to 26 inches, or less to allow for altitude.

<sup>1</sup> *Quarterly Journal of the Royal Meteorological Society*, 1887, vol. xiii., p. 201.

The space above the mercury in the barometer tube is still called the "Torricellian vacuum," and, provided the tube has been properly filled, this space should contain nothing except a little of the vapour of mercury.

As mercury expands with heat, it is essential that a thermometer should be attached to every barometer, in order to show the temperature of the mercurial column. Once this value is ascertained, a suitable correction must be applied to the reading of the barometer, so as to reduce it to the fixed or standard temperature of 32° F.

The mercurial barometer is best mounted in a brass case, because the coefficient of expansion of brass by heat is well known—a matter of great importance, as the tables for correcting readings for temperature are based upon the coefficients of expansion of mercury, glass, and brass. Barometers mounted in wood are of inferior value for scientific purposes.

The attentive reader will at this point suggest to his own mind two difficulties in the construction of the barometer. One is, how to cover the cistern so as to prevent the escape of the mercury, and so render the instrument portable without interfering with atmospheric pressure on the surface of the mercury contained in the cistern. This is effected by constructing the bottom of the cistern of leather, as in the Fortin barometer; or by covering a small cavity in the roof of the cistern with leather, as in the Kew barometer.

Again, it is evident that the *level* of the mercury in the cistern will change according as the barometer rises or falls. If it rises, there will be more mercury in the tube and less in the cistern, and the level of the mercury in the latter will fall. On the other hand, if the barometer falls, there will be less mercury in the tube and more in the cistern, in which the level of the mercury will in consequence rise. In a word, "the zero of the scale does not always correspond with the level of the mercury in the cistern" (Fred. J. Brockway). As in all cases the height of the barometer is calculated from the level of the mercury in the cistern, we must apply a correction for the error arising from the change of level in the cistern—the "error of capacity," as it is called. Formerly tables for applying a "capacity correction" were employed,

but they are not now required, owing to the adoption of barometers of the Fortin, Kew, or Siphon patterns.

- (1) The Fortin barometer has a pliable or flexible base to its cistern.
- (2) The Kew barometer has a contracted scale.
- (3) The Siphon barometer dispenses with the use of a cistern altogether.

1. In the Standard Barometer (German, *Hauptbarometer* ; French, *Baromètre étalon*), commonly called Fortin's barometer (Fig. 23), the starting-point, or zero, of the scale is formed by an ivory pin, which must be brought into exact contact with the surface of the mercury in the cistern whenever an observation is made. This is effected by fixing a screw below and in contact with the flexible leather bottom of the cistern. The adjustment is made by means of a thumb-screw, which raises or depresses the flexible leathern base of the cistern until the tip of the ivory pin—technically called the *fiducial point*—and its image reflected in the mercury in the cistern appear exactly to touch each other, when viewed through a glazed aperture in the wall of the cistern.

In Fig. 24 an ingenious arrangement, devised by Mr. Wallis, for facilitating the adjustment of the

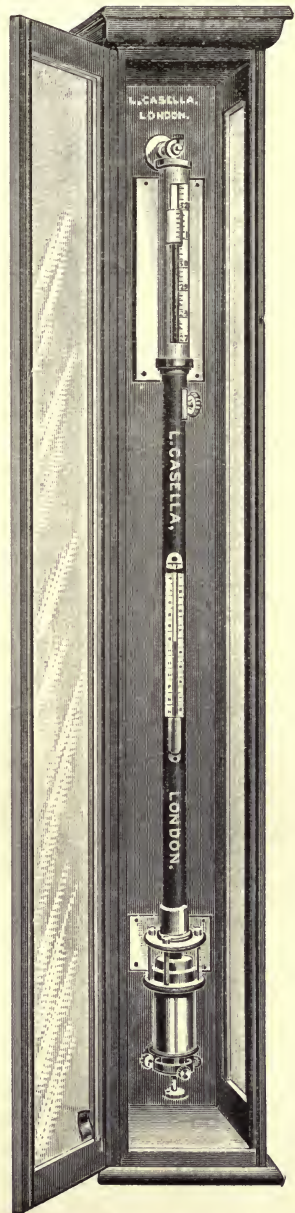

FIG. 23.—FORTIN BAROMETER.

barometer scale, is represented. It can be clamped to any of the barometers constructed on the Fortin principle.

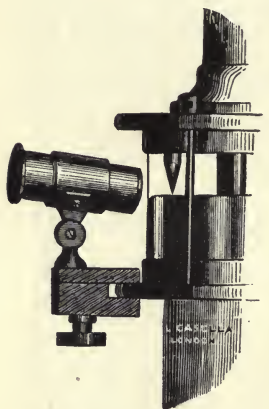

FIG. 24.—WALLIS'S ARRANGEMENT FOR ADJUSTING THE IVORY POINT.

2. In 1853 Mr. P. Adie, of Edinburgh, invented a barometer for use at sea, which is commonly known as the Kew barometer (Fig. 25). It is so called because it was recommended by the Kew Committee of the British Association for adoption by the Government as best suited for marine observations then about to be commenced by the Admiralty and the Board of Trade. Its distinctive features are a brass frame, a contracted tube, having a pipette, a closed cistern, and a scale of contracted inches. In this, the "Marine Barometer," the tube is of small calibre throughout the greater part of its length in order to lessen the oscillations of the mercury caused by the ship's motion, which are technically known as "pumping." This renders the instrument rather sluggish, but not materially so. The cistern is entirely composed of iron (because brass, being an alloy, is liable to be acted on by mercury), and only a small aperture in its roof is left through which atmospheric pressure is able to exert itself on the contained mercury. This aperture is, as has been said above, covered with leather to prevent the escape of the mercury.

In this instrument the "error of capacity" is compensated by contracting the divisions on the scale from above downwards, in proportion to the relative sizes of the tube and the cistern. In ordinary Kew barometers the diameter of the tube is about  $\cdot 25$  inch, and that of the cistern about  $1\cdot 25$  inch. Accordingly, starting from 32 inches correctly marked off from a

Its distinctive features are a brass frame, a contracted tube, having a pipette, a closed cistern, and a scale of contracted inches. In this, the "Marine Barometer," the tube is of small calibre throughout the greater part of its length in order to lessen the oscillations of the mercury caused by the ship's motion, which are technically known as "pumping." This renders the instrument rather sluggish, but not materially so. The cistern is entirely composed of iron (because brass, being an alloy, is liable to be acted on by mercury), and only a small aperture in its roof is left through which atmospheric pressure is able to exert itself on the contained mercury. This aperture is, as has been said above, covered with leather to prevent the escape of the mercury.

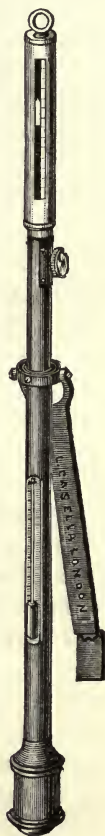

FIG. 25.  
KEW BAROMETER.



definite point below, the "inches" of the scale are shortened in the proportion of .04 inch for every true inch.

Every tube is fitted with an "air-trap," which is a small funnel or pipette inserted somewhere between the range of the column and the neck of the cistern. The pipette was first proposed by Gay-Lussac in order to stop the ascent into the Torricellian vacuum of any air or moisture which may work its way from the cistern into the tube between the glass and the mercury (Fig. 26).

The so-called "Gun Barometer" was designed by Admiral Robert FitzRoy, in 1861, for the naval service. It is a modification of the marine barometer, and is intended to withstand the concussion of heavy ordnance. The glass tube is surrounded wherever possible with vulcanised india-rubber tubing as packing. This checks the vibration from firing, but does not hold the tube too rigidly.

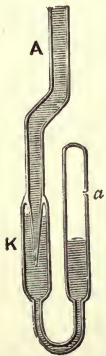

FIG. 26.  
GAY-LUSSAC  
AIR-TRAP.

3. To Gay-Lussac we owe the Siphon barometer, which consists of a bent glass tube of uniform calibre, but with one branch or leg much longer than the other. The longer limb is closed at the end, and carefully filled with pure mercury, the shorter limb is quite open, and serves as a cistern. As the mercury falls in the long limb, leaving the Torricellian vacuum above it, it must rise to an equivalent height in the short limb. The motion in each limb is exactly one-half of what takes place in a Fortin barometer. The atmospheric pressure, or "height of the barometer," is the difference between the two levels, so that two readings must on every occasion be taken—one, of the level of the mercury in one limb; the other, of the level in the other limb. This instrument is the only mercurial barometer suitable for mountain climbing, owing to its lightness and portability (Fig. 27).

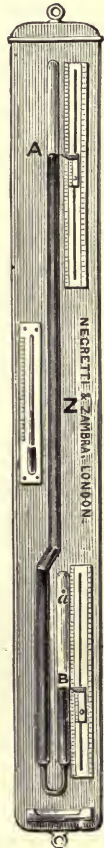

FIG. 27.  
SIPHON  
BAROMETER.

The ordinary wheel barometer, or "weather glass," was invented in 1665-66 by Robert Hooke, Secretary of the Royal Society. It is a siphon barometer. Resting on the mercury in the shorter limb is a float connected by a silken cord with a light counterpoise at the other side of a fixed pulley, round which the cord is coiled two or three times. A needle indicator attached to the axis of this pulley rotates with the rise and fall of the mercury round a graduated circular dial, on which are also the words: "set fair," "fair," "change," "rain," "much rain," and "stormy." These words are intended to indicate what weather may be expected when the needle points to each part of the dial.

Although a popular instrument, the wheel barometer is of no scientific value. Its principle, however, has been applied in the construction of one form of self-registering barometer, or *barograph* (Greek, βάρος, *weight*; γράφω, *I write*). A pencil is attached to the cord connected with the float, and this pencil is so arranged that it draws a continuous tracing on ruled paper, which is moved by clockwork.

In a modified barograph of this kind ruled metallic paper spread on a revolving vertical drum of about 4 inches diameter is pierced at given intervals (usually every hour) by a needle shot out by clockwork, and ingeniously connected by means of a pulley with the mercurial surface in the short limb of a siphon barometer. The drum or cylinder in this barograph is made to revolve once a week by means of clockwork.

One of the costliest barographs in existence was designed in 1853 by the late Mr. Alfred King, C.E., of Liverpool (Fig. 28). About 130 pounds of mercury are employed in the construction of this instrument, and the effects of friction, which are the great drawback in wheel barometers, are entirely overcome by the most sensitive mechanical arrangements. In this ingenious barograph the tube is partly supported by the mercury in the fixed cistern, which, as it rises and falls, raises and depresses the tube. A delicate mechanical contrivance records this change of level continuously on a revolving drum. The barometric column is made to show nearly 6 inches for each inch of the ordinary barometer. This instrument has for many years been in use at the Bidston

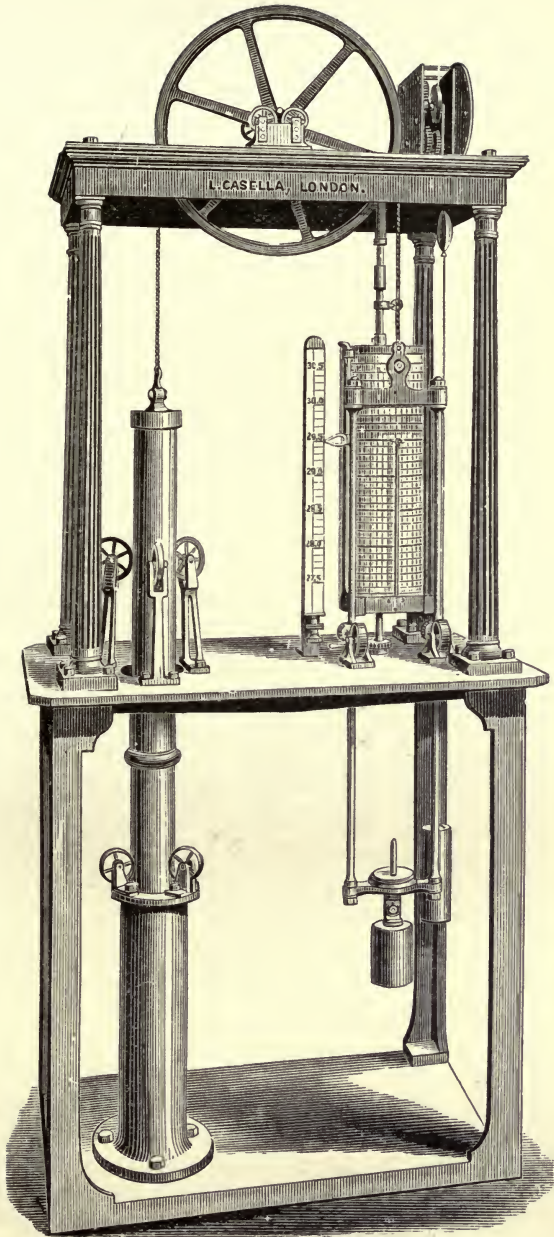

FIG. 28.—ALFRED KING'S BAROGRAPH.

Observatory, near Liverpool. It is fully described in the late Mr. Hartnup's "Report to the Mersey Docks Board for 1865."

Dr. R. H. Scott, F.R.S., speaking of barographs,<sup>1</sup> observes: "The principle of registration generally adopted in this country for the better class of barographs is photographic, not mechanical."

The late Sir Francis Ronalds in 1847 designed a photographic barograph which, in a modified form, is employed in the First Order Stations of the Meteorological Office, London. The principle of the instrument is described at length in the "Report of the Meteorological Committee of the Royal Society for 1867" (pp. 40-42). "The barometer is of the ordinary pattern, and the light is admitted through the Torricellian vacuum, so that the actual height of the mercury itself is photographed without the intervention of any mechanical contrivance" (R. H. Scott).

Those who are interested in this subject of barographs will find at p. 412 of the second volume of the *Quarterly Journal of the Meteorological Society* a description of a new barograph invented by M. Louis Redier, which was communicated to the Society on March 17, 1875, by the late Mr. G. J. Symons, F.R.S. The apparatus is so arranged that all the work is done by a powerful clock-movement, and the barometer, of the siphon type, has only to direct the action of the clockwork.

In 1886 M. Redier, in a pamphlet, described a later form of his mechanical barograph under the title "Nouveau baromètre enregistreur à mercure." In it the barometer is at rest. A differential clock train keeps a light horizontal arm in continuous slight vertical oscillation close to the point of a stalk rising from the mercury in the lower branch of a siphon tube. As the arm follows the stalk in all its variations of position, the barometric variations, through a pencil, become continuously recorded.

In addition to *mechanical contrivances* and *photography*, *electricity* has been employed in the construction of the barograph. Sir Charles Wheatstone, in the *British Association Report* for 1842, suggested the adaptation of electricity for the purpose. He proposed that a platinum wire, controlled by a clock, should make

<sup>1</sup> *Elementary Meteorology*, p. 77.



contact at given intervals with the mercury in the tube of a barometer or other instrument—for example, the dry and wet bulb thermometers—so creating an electric current which should determine both the record and the value of the element (W. Ellis). This principle has been since applied in the barographs included in the combined meteorographs of Salleron (1860), Theorell (1869), and Van Rysselberghe (1873), the records being all intermittent.

*The Aneroid Barograph.*—The motion in most barographs is supplied by a set of aneroid boxes (see p. 132 for a description of

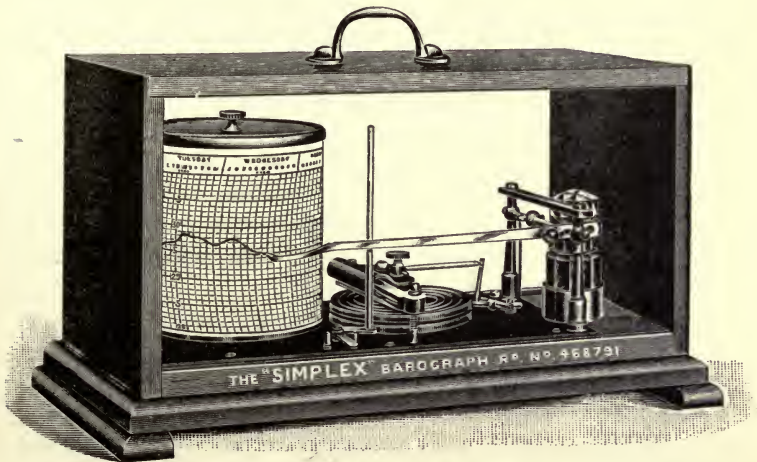

FIG. 29.—THE ANEROID BAROGRAPH.

the “aneroid barometer”) (Fig. 29). The instruments used at official stations of the Meteorological Office are of two sizes. The parts of the apparatus which affect the size and ruling of the charts are (1) the length of the arm carrying the pen, measured from pivot to pen-point; (2) the height of the pivot of the pen-arm above the flange on the drum, against which the chart rests; (3) the magnification of the pen motion—*i.e.*, the vertical distance on the chart corresponding with a change of pressure of 1 inch of mercury. The last depends on the number and size of the aneroid boxes and on the arrangement of the levers. The horizontal distance on the Meteorological Office charts corresponding

with an interval of twelve hours is also given. These dimensions are as follow :

	Large Instrument.	Small Instrument.
	Inches.	Inches.
Length of pen-arm .. ..	10·24	7·29
Height of pivot above flange ..	3·14	1·57
Magnification of scale .. ..	2·04	1·00
Twelve hours on time scale ..	1·05	0·78

The diameters of the drums are respectively 4·97 inches and 3·65 inches. The scale usually reads from 28 to 31 inches. Both these limits have, however, been exceeded.

Barographs in which the motion of the pen is furnished by a set of aneroid boxes are subject to changes of zero. When absolute pressure values are required, their use must accordingly be confined to interpolating between the readings of standard mercurial barometers. A barograph needs no special exposure, but it should be protected from shaking and from sudden changes of temperature.

*Transmission of Barometric Indications by Electricity.*—In 1882, Mr. John Joly (now Professor Joly, F.R.S.), of Dublin, described in *Nature* (vol. xxv., p. 559) a plan for ascertaining the reading of a distant mercurial barometer, connected with the recording station telegraphically. He carries two wires through the head of the barometer tube. One of these of a given diameter is continued downward into the mercury to a point below which the mercury never falls. The continuation of the other is a fine carbon thread, also of a given diameter, carried to the same point, and there joined to the wire. The outer ends of the wires pass to the recording station, an electric current sent from which traverses both wire and carbon in its passage. The carbon being a substance of high resistance, a very small change in its effective length due to the rise or fall of the mercury in the barometer tube, exposing less or more of the fine carbon thread, will tell on the potential of the returning current. This variation of potential would, in Mr. Joly's opinion, be sufficiently marked to enable an observer at the recording station to measure the barometric

variations at a station four miles distant, involving eight miles of wire.

*Bartrum's Open-Scale Barometer.*—This instrument exhibits changes of barometer pressure with great facility and accuracy, and is exceedingly rapid in responding to such changes.

The lower part of this instrument, of which the sole maker is Mr. James J. Hicks, of Hatton Garden, London, E.C., is formed in the same way as an ordinary mercury barometer. The tube in the neighbourhood of the upper surface of the mercury column is enlarged, and above the surface is again reduced in calibre, and continued upwards for 27 inches or more. The space above the mercury and for some distance up the narrow tube contains a light red fluid, the position of the upper surface of which, along an attached scale, gives the barometer reading.

The principle is as follows: On account of the change in calibre of the tube, a rise of the mercury in the enlarged part, which we will call the bulb, will cause a very much greater rise of the light fluid in the upper tube. The change of atmospheric pressure causing the rise is represented by the fall of mercury in the cistern, added to the rise of mercury in the bulb, again added to the increase in length of the column of light liquid (the last reduced to its equivalent length of mercury).

As an example, suppose the cistern and bulb to be of the same calibre and each to have a sectional area fifty times as great as that of the upper tube, and suppose the mercury in the cistern to fall 0·1 inch. The mercury in the bulb will then rise 0·1 inch and the liquid in the upper tube 5 inches, a change in length of the upper column of 4·9 inches. The liquid used has a density about one-twelfth that of mercury, so that a column of 4·9 inches would correspond to 0·41 inches of mercury. Five



FIG. 30.—BARTRUM'S OPEN-SCALE BAROMETER.

inches on the scale will therefore correspond to  $0.1 + 0.1 + 0.41 = 0.61$  inches of mercury, or 8.2 inches of scale to each inch of reading. The range of the scale can be made as open in this barometer, which is 5 feet long, as in a glycerine barometer, which is over six times as long—viz., 32 feet.

The instrument is mounted in a very neat and strong mahogany frame, with glass door. By a momentary adjustment it becomes portable, and can be carried with ease and safety. The effect of change of temperature is inappreciable. Owing to the extremely open range of this barometer (over 8 inches to an inch of mercury), no vernier is required, and a reading can easily be taken to  $\frac{1}{1000}$ th of an inch.

Before explaining the method of reading the barometer, it may be well to describe some substitutes for mercurial barometers which have been devised.



FIG. 31.—EXTRA-SENSITIVE ANEROID BAROMETER.

The *Aneroid Barometer* is the chief of these. It was invented by M. Vidi, of Paris, in 1843, and patented in the following year. The French patent is dated April 19, 1844. As the name implies, it contains no fluid (Greek,  $\alpha$ , priv. ;  $\nu\eta\rho\acute{o}s$ , *wet* or *damp*, hence *liquid* or *fluid* ; and  $\epsilon\acute{\iota}\delta\omicron>s$ , *form* or *shape*). For this reason the aneroid is also known as the “holosteric barometer,” the

word “holosteric” meaning “entirely solid” (Greek,  $\delta\lambda\omicron>s$ , *whole* ;  $\sigma\tau\epsilon\rho\epsilon\acute{o}s$ , *solid*). In this ingenious instrument (Fig. 31) the pressure of the atmosphere is measured by its effect in altering the shape of a small, hermetically sealed, partially exhausted metallic box called the “vacuum chamber.” This vacuum chamber is composed of two discs of corrugated German silver soldered together. Its sides are made in concentric rings, so as to increase their elasticity, and one of them is fastened to the back of the brass case which contains the whole mechanism. A strong spring also fixed to the case is so arranged as to act in opposition to the motion of the vacuum chamber, preventing its sides collapsing when the effect of reduced atmospheric pressure is added to that of extreme exhaustion of the chamber. A lever, composed of iron and brass, so as to compensate for changes in temperature, connects



the spring, by means of a bent lever at its further end, with a watch-chain, which is wound about an "arbor" (axle or spindle). An index-hand or pointer, fixed to the arbor in front, is by its revolution caused to rotate backwards and forwards over an experimentally graduated dial, and so is made to mark the variations in atmospheric pressure from time to time. A very slight alteration of the size of the vacuum chamber produces a large deviation of the index-hand,  $\frac{1}{20}$ th of an inch, causing it to move through 3 inches as marked on the dial.

When pressure increases, the falling in of the corrugated sides of the vacuum chamber will pull upon the lever, which in turn, acting through the second or bent lever, will pull upon the chain, drawing it off the arbor, and so causing the pointer to move across the dial towards the right, marking high pressures.

When pressure decreases, the expansion of the vacuum chamber will allow the compensating spring to push away the lever, which will relax the chain, allowing it to be wound round the arbor by a spiral hair-spring, which will move the arbor and pointer towards the left, marking low pressure.

In 1851 Rusk added an altitude scale to the aneroid barometer.

A Metallic Barometer, designed by M. Bourdon in 1851, is a modification of the principle of the aneroid.

This instrument is described in Besant's *Elementary Hydrostatics* (chap v., "Notes,"), and in the Report of the Jury on Philosophical Instruments in the Great Exhibition of 1851, as well as in a lecture by Mr. James Glaisher, F.R.S., on these instruments. It consists of a thin elastic metal tube of elliptic section, in shape a portion of a circle, closed at its ends and exhausted of air. Alterations in the pressure of the atmosphere are indicated by the ends of the tube approaching towards each other when pressure increases, and receding from each other when pressure diminishes. These motions are communicated by gearing work to an index-hand traversing a dial plate. No definite explanation of the principle of action of this instrument was offered until the Rev. E. Hill, M.A., Fellow of St. John's College, Cambridge, communicated a paper on the subject to the Meteorological Society on February 21, 1872. The above particulars are taken partly from Mr. Ellis's address, but chiefly from Mr. Hill's com-

munication. His explanation, however, is of too recondite a nature to be reproduced here.

Aneroids, while very sensitive, are apt to get out of order owing to defects in construction, rusting, or loss of elasticity in the springs. They are, therefore, not used at Second Order Stations or for concerted observations, for which accurate mercurial barometers are indispensable.

If an aneroid is employed, its readings should be frequently compared with those of a reliable mercurial barometer reduced to  $32^{\circ}$  F. It is a popular instrument because of its convenient size and portability. Besides, it requires no correction for its own temperature, for it must be remembered that the "aneroid readings correspond to readings of the mercurial barometer reduced to  $32^{\circ}$ " (W. Mariott).

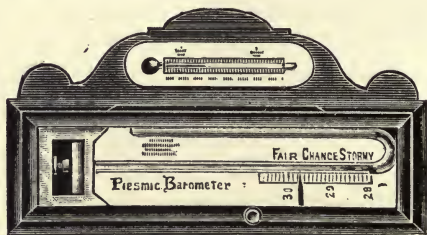

Position when not in use.

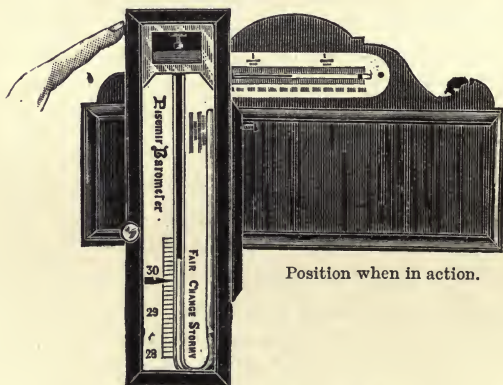

Position when in action.

FIG. 32.—THE PIESMIC BAROMETER.

*The Piesmic Barometer.*—This ingenious instrument, invented by Mr. A. S. Davis, M.A., is based on the principle that air is

more compressible when the barometer is low than when it is high. In the Piesmic Barometer (Greek,  $\pi\acute{\iota}\epsilon\zeta\omega$ , I squeeze or press) a tubeful of air is taken at atmospheric pressure, and its compressibility is tested by allowing mercury to run down the tube and compress the air inside. The depth to which the mercury descends varies with the compressibility of the enclosed air, and therefore also with the barometric pressure at the time. The reading of the scale gives the atmospheric pressure in inches of mercury. The instrument is illustrated in the accompanying figure (Fig. 32). By employing an air-tight case, and drying the air before finally closing the cistern, any error arising from the humidity of the air is entirely avoided.

A self-recording mercurial barometer (Fig. 33) has been designed by W. H. Dines, Esq., F.R.S., to give a trace from which the height at any time may be determined to  $\cdot 005$  inch. This end is



FIG. 33.—DINES'S SELF-RECORDING MERCURIAL BAROMETER.



attained by arranging the details of construction so that the friction of all the moving parts, and more particularly that between the pen and the paper, may be very small, and also by an automatic temperature correction.

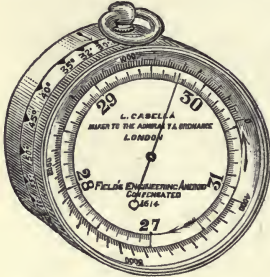

FIG. 34.—FIELD'S ENGINEERING ANEROID BAROMETER.

The pen is actuated by a float in the lower cistern, the motion being multiplied by a lever so that a length of  $1\frac{1}{2}$  inches on the paper may correspond to a change of 1 inch in the height of the barometer. The float is in the form of a hollow cylinder sealed at the top, and floating mouth downwards in the mercury. A rise of temperature lowers the level of

the mercury in the lower cistern, but at the same time it expands the air in the float, and makes it swim higher in the mercury. The volume of air is so adjusted that there may be a complete compensation. There is an additional pen fixed to the frame, which draws a line of reference on each sheet of paper while it is on the clock drum, and for accurate measurement this line is taken as the zero line, since by this means the error that might be caused by placing the chart unequally on the drum, or by an incorrect printing of the charts, is avoided. The price, complete in glass case, with lock and key, including supply of charts and ink, is £30.

*Measurement of Altitudes.*—An aneroid in good order will show with precision the difference in height between the various stories in a lofty house, the varying gradients in travelling on a railway, and mountain or balloon elevations—it may be up to 24,000 feet. One of the chief uses of the aneroid, indeed, is the measurement of altitudes. Owing to the elasticity of the atmosphere, the reduction of pressure does not proceed evenly with altitude, and accordingly special altitude scales have been computed, which are engraved on the dial of the instrument.

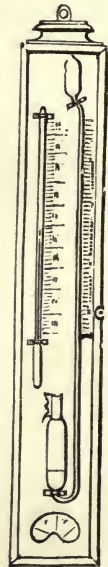

FIG. 35.—ADIE'S SYMPLESOMETER.



A correction for the temperature of the air (not for that of the instrument, for the reason given above) must always be made, and so in the "Engineering Aneroid," invented by Mr. Rogers Field, B.A., M.Inst.C.E., F.R.Met.Soc., and manufactured exclusively by Mr. L. Casella, this correction is taken into account by making the scale adjustable for temperature (Fig. 34).

While on this subject, it will be well briefly to describe two other instruments which are used for ascertaining the altitude—one a barometer, the other a thermometer—the *sympiesometer* and the *hypso-meter* respectively.

The *sympiesometer*, or "compression measure" (Greek, συμπίεσις, *compression*; from συμπιέζω, *to press or squeeze together*; μέτρον, *a measure*), was invented by Mr. P. Adie, of Edinburgh (Fig. 35). It is a sensitive but unreliable kind of barometer (using this term in its strict etymological sense), consisting of a glass tube 18 inches in length and  $\frac{3}{4}$  of an inch in diameter which terminates in a closed bulb above, and, after a sharp bend, in an open cistern below. The pressure of the air,

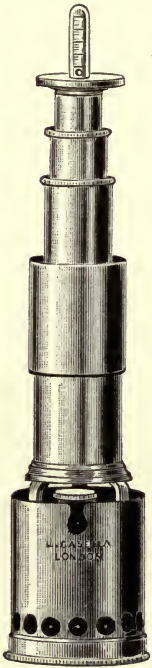

FIG. 36.—CASELLA'S HYPSONETER.

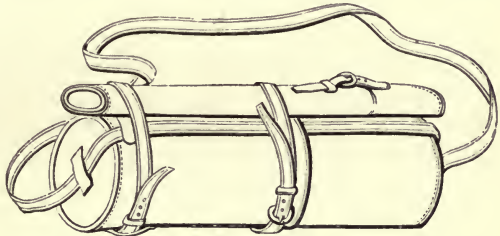

FIG. 37.—PORTABLE LEATHER CASE FOR HOLDING CASELLA'S HYPSONETER.

acting through the latter on the surface of a fluid, such as oil or glycerine, in the lower part of the cistern and of the tube, forces it upwards so as to compress an elastic gas, such as hydrogen or air, in the upper part of the tube and in the bulb. The amount of compression is read off on an adjustable scale, the index of which must be set to the division on the scale corresponding to the temperature indicated by an attached thermometer.

The principle of the *hypsoneter* (Greek, ὕψος, *height*; μέτρον, *a measure*) is based on the fact, already referred to in Chapter VII., p. 79, that the boiling-point of water falls according as atmospheric pressure is reduced. The instrument consists of a vessel for water, with a spirit-lamp for heating it, and an enclosed thermometer for showing the temperature of ebullition. In Casella's hypsoneter (Figs. 36 and 37), a strong, small-bulbed thermometer, divided and figured on the stem, is sheltered from cold when in use by a double telescopic chamber, into which it is introduced to any required depth through a loose piece of indiarubber at the top. When the water boils, the vapour fills the inner chamber and envelops the thermometer, bulb and stem alike, finally descending in the outer chamber and escaping by a pipe outlet. Mr. Casella has constructed a smaller instrument on the same principle, which is much used by Alpine travellers.

*A New Form of Open-Scale Barometer.*—Professor W. F. Barrett, F.R.S., has recently devised a simple form of open-scale barometer, or weather-glass, to which a brief reference may be made. It resembles an air-thermometer, but, the bulb and tube being rendered practically impermeable to changes of temperature, the movement of the liquid index indicates changes of atmospheric pressure. This is accomplished by using a Dewar liquid air flask for the bulb, and surrounding the index-tube with a wider sealed glass tube from which the air has been thoroughly exhausted. The Dewar liquid air-flask, as is well known, consists of a double or jacketed glass bulb, the space between the two envelopes being highly exhausted in a reflecting film of silver or mercury deposited on the inner surface of the outer envelope. By this means the transmission of heat from the outside is almost wholly prevented. In practice this form of weather-glass has been found to be both very sensitive and reliable. This ingenious instrument was shown, and its action demonstrated, at a scientific meeting of the Royal Dublin Society on February 22, 1910.

## CHAPTER XII

### BAROMETRICAL READINGS

SINCE mercury expands by heat and contracts by cold, it is necessary that every barometer should carry a thermometer closely attached to its metal case, or preferably to its glass tube and cistern. By means of this "attached thermometer" the observer is placed in a position to apply a proper correction to the reading of the barometer, with the view of reducing that reading to the fixed standard of temperature, or 32° F.

Before any observation is made, the barometer should be mounted in a room with an equable temperature, not near a fireplace or a stove. Its scale should be on a level with the observer's eye—5 feet or 5 feet 6 inches above the floor. It must hang vertically: "*Care should be taken that no readings from a barometer which is not hanging truly vertically should ever be recorded.*"<sup>1</sup> "To facilitate readings, a piece of white paper or of opal glass should be fixed immediately behind the part of the tube at which the readings are taken; and if the barometer be of the Fortin pattern another piece should be placed behind the cistern."<sup>2</sup> This arrangement may be seen well represented in Fig. 23 above (p. 123).

The method of taking a barometrical observation is as follows:

1. The attached thermometer should first be read, no matter what kind of barometer is employed. The temperature of the external air (dry-bulb reading) should also be taken.

2. Next, in the case of a Fortin or standard barometer, the mercury in the cistern should be adjusted by turning the screw

<sup>1</sup> *Instructions in the Use of Meteorological Instruments*, compiled by Robert H. Scott, M.A., F.R.S. Reprinted 1885.

<sup>2</sup> *Hints to Meteorological Observers*, sixth edition, p. 6. By William Marriott, F.R.Met.Soc. 1906.

at the bottom, so that the tip of the ivory pin, or the *fiducial point*, should barely touch the surface of the mercury. This manipulation is not required, nor is it possible, in the case of the Kew barometer, in which (as has been explained) the scale of shortened inches compensates for the error due to capacity.

3. The barometer tube should, after this, be gently tapped to overcome any tendency to adhesion between the mercury and the glass, and to allow capillary action to assert itself.

It is necessary to mention that, in obedience to what is called "capillary action," a liquid like water, capable of wetting a clean glass tube open at both ends, will rise in such a tube above the level of its surface in the vessel containing it, and higher and higher according to the fineness of the bore of the tube. Hence the term "capillary," from the Latin "capilla," a *fine hair*. Further, the liquid will stand above the general level in the tube where it approaches the sides, so that its upper surface in the tube will be curved and *concave*, owing to *capillary attraction*. On the other hand, a liquid like mercury, incapable of wetting such a tube, will stand in the tube below the level of its surface in the vessel, and where it approaches the sides of the tube, its level will be below its general level in the tube, so that its upper surface will be curved and *convex*, owing to *capillary repulsion*. This causes the mercury in a barometer always to stand a little lower than the height due to atmospheric pressure, and necessitates a correction for *capillarity*. Such a correction is less in a barometer in which the mercury has been boiled in the tube than in an unboiled tube, for by the boiling a film of air, which in unboiled tubes adheres to the glass, is expelled. The error is also reduced by widening the bore of the tube; for example, the depression in a boiled tube of  $\frac{1}{4}$  inch in diameter is  $\cdot 02$  inch, whereas in a similar tube of  $\frac{1}{2}$  inch diameter it is only  $\cdot 003$  inch.

4. It follows from the foregoing that, in reading a barometer, the height should be taken from the very apex of the convexity, or of the *meniscus*, as it is called (Greek, *μηνίσκος*, a *crescent*; from *μήνη*, the *moon*). This is done by means of a small movable scale called the vernier, to which a sliding piece at the back of the instrument is connected so as to move with it. To take a reading, the lower edge of the vernier and the lower edge of the



sliding piece behind should be brought, by turning the mill-head pinion which moves the rack up or down, to form a tangent with the convex surface of the mercury. As Mr. Marriott well remarks: "The front and back edges of the vernier, the *top* of the mercury, and the eye of the observer must be in the same straight line."

The object of the sliding piece at the back of the instrument is to insure that the observer's eye is at the same level as the domed top of the mercury column. Whenever the index and the scale on which it is read are not in the same plane, serious errors are made, which are known as *errors of parallax*.

But what is the *vernier*? It is a short scale named after its inventor, Pierre Vernier, made to slide by means of a rack and pinion along the divisions of a graduated scale, such as that of a barometer, and its divisions are so contrived as to be slightly shorter than those of the barometer scale, which is generally divided into inches, tenths, and half-tenths, or five-hundredths ( $\cdot 05$ ) of an inch. The vernier is made equal in length to twenty-four half-tenth divisions of the barometer scale, and is then itself divided into twenty-five equal parts. From this it follows that each space on the vernier scale falls short of a space on the barometer scale by the twenty-fifth part of  $\cdot 05$  inch, or

$$\frac{1}{25} \times \frac{1}{2} = \frac{1}{50} = \frac{1}{500} = \frac{1}{100} = \cdot 002 \text{ inch.}$$

Each division of the vernier, therefore, represents a difference of  $\cdot 002$  inch, or  $\frac{1}{500}$  inch in pressure, while by interpolating a reading between any two divisions of the vernier, we are enabled to read the pressure to  $\cdot 001$  inch, or  $\frac{1}{1000}$  inch.

In using the vernier, the division on the barometer scale at or below which the lower edge of the vernier stands after setting it should first be read off. In the accompanying figures (38 and 39) two cases are illustrated. In one (that to the left), the lowest line on the vernier scale exactly coincides with the division 29.50 on the barometer scale. The reading is therefore 29.500 inches precisely. In the other (that to the right), the reading on the barometer scale gives us 29.65, but the height of the column of mercury is in reality that amount in inches *plus* the vernier indication.

On looking up the vernier scale in this case, we find that both the second and the third divisions above the figure 3 apparently

coincide with a division on the barometer scale. It is therefore necessary to take a mean reading, and to add the decimal .035 to the first reading, thus :

$$29.65 + .035 = 29.685 \text{ inches.}$$

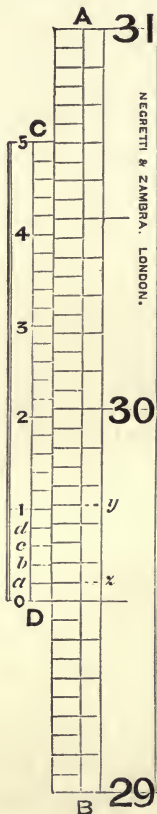

Case 1.  
FIG. 38.

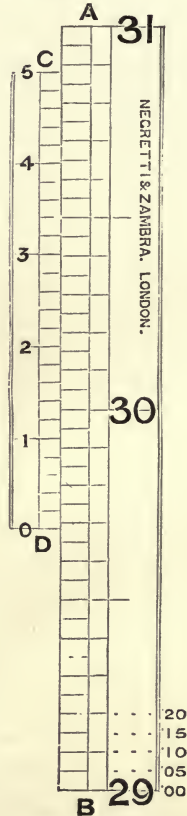

Case 2.  
FIG. 39.

METHOD OF READING THE VERNIER.

In cases where it is hard to say which division of the barometer scale is that *below* the lower edge of the vernier, the reading of the latter will itself point out which division on the barometer scale should be taken. For example, in the left-hand drawing the

correct reading is manifestly 29·500 inches, not  $29\cdot50 + \cdot050 = 29\cdot550$  inches. In fact, the value of the vernier reading in the example is zero :  $29\cdot50 + \cdot000 = 29\cdot500$  inches.

It may be well to repeat, what has been already conveyed in different words, that English barometers are usually graduated in the following way :

1. Every long line cut on the barometer scale represents  $\frac{1}{10}$  inch ( $\cdot100$  inch).
2. Every short line cut on the barometer scale represents  $\frac{1}{20}$  inch ( $\cdot050$ ).
3. Every long line cut on the vernier scale represents  $\frac{1}{100}$  inch ( $\cdot010$  inch).
4. Every short line cut on the vernier scale represents  $\frac{2}{1000}$  inch ( $\cdot002$ ) inch.

#### CORRECTIONS TO BE APPLIED TO READINGS OF THE BAROMETER.

Before barometrical readings taken synchronously at different places by various observers can be compared with each other and used for scientific purposes a number of corrections must be applied to the recorded readings. Many of these corrections have been already mentioned, but all of them must now be referred to and classified according as they relate to a given instrument, or are applicable to the readings of any instrument taken under the same conditions.

The corrections of the former class are *three* in number—

- I. Index error.
- II. Capacity.
- III. Capillarity.

Those of the latter class are also *three* in number—

- IV. Temperature.
- V. Altitude, or height above sea-level.
- VI. Gravity.

I. *Index Error*.—This is detected by careful comparison with a recognised standard barometer. It includes all errors in graduation of the scale. The detection of the index error is simple in the case of the Fortin barometer, but complicated in

that of the Kew barometer. The latter instrument must be tested at every  $\frac{1}{2}$  inch of the scale from 27 to 31 inches, because its inches are less than true inches. To pass through this ordeal it is necessary to use artificial means of increasing or reducing pressure, and so the instrument and the standard have to be placed in an air-tight chamber connected with an air-pump. The instruments can thus be made to read higher or lower as the air in the chamber is compressed or exhausted. Glass windows through which the instruments can be seen are placed in the upper part of the iron air-tight chamber, but, of course, the verniers cannot be used, as the observer is outside the chamber. To overcome this difficulty an apparatus called a cathetometer (Greek, *κάθετος*, *let down*; hence, *ἡ κάθετος* [sc. *γραμμὴ*], *a perpendicular line, a perpendicular height*; *μέτρον*, *a measure*) has been devised. This is a vertical scale, on which a vernier and a telescope are made to slide by means of a rack and pinion. The divisions on the scale correspond exactly with those on the tube of the standard barometer. The cathetometer (Figs. 40, 41, and 42) is placed at a distance of 5 or 6 feet from the air-tight chamber. The telescope carries two horizontal wires, one fixed, and the other capable of being moved by a micrometer screw. The difference between the height of the column of mercury and the nearest division on the scale of the standard can be measured either with the vertical scale and vernier, or with the micrometer wire. The errors detected in this way include not only the index error, but also the correction required for capillarity.

II. *Capacity*.—The meaning of this term has been already explained. It will be remembered that the siphon barometer requires no correction for capacity. In the Fortin barometer it is provided for by adjusting the scale to the level of the mercury in the cistern, and in the Kew barometer, by shortening the “inches” cut on the scale. In barometers with closed cisterns and a scale of true inches engraved on the case, there is a certain height of the mercurial column, which is correctly measured by the scale. This is called the *neutral point*, and it should be marked on the scale by the maker, who should also state the ratio of the interior area of the tube to that of the cistern thus:  $\text{Capacity} = \frac{1}{56}$ .

From these data the correction for capacity is found by taking



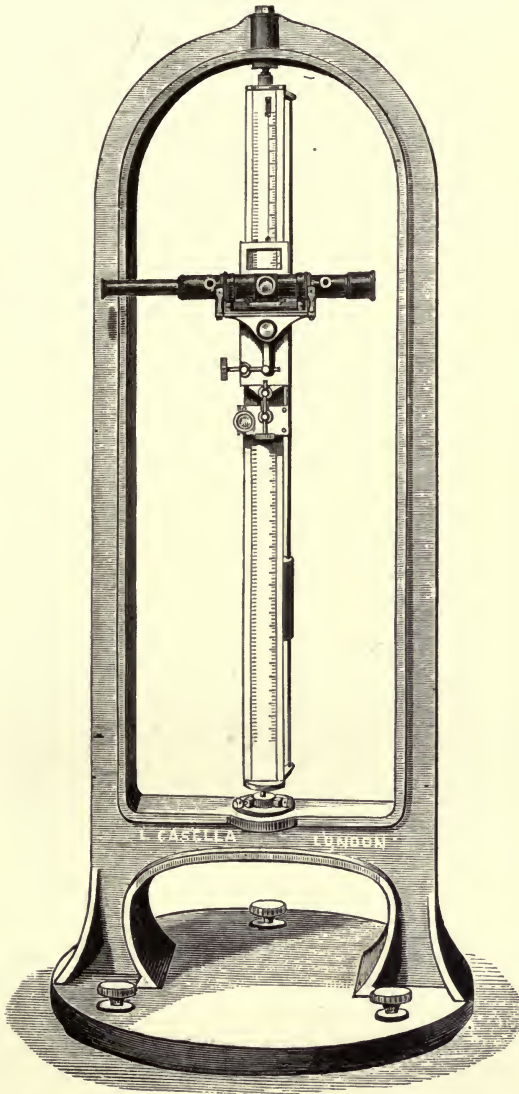

FIG. 40.—CATHETOMETER CONSTRUCTED FOR THE INDIAN GOVERNMENT.

a fiftieth part of the difference between the height read off and that of the neutral point, adding the resulting value to the reading

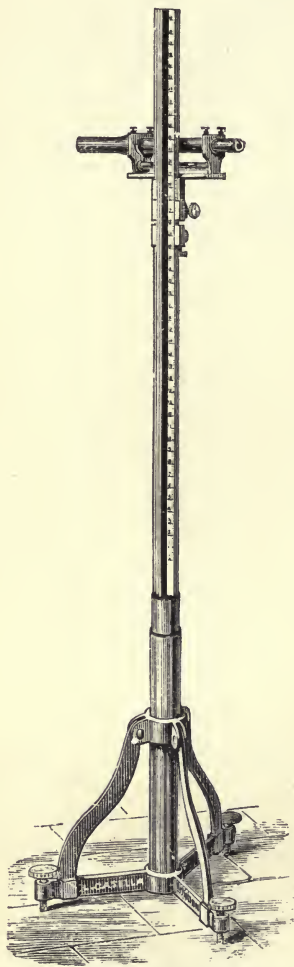

FIG. 41.—CATHETOMETER, AS USED AT KEW OBSERVATORY.

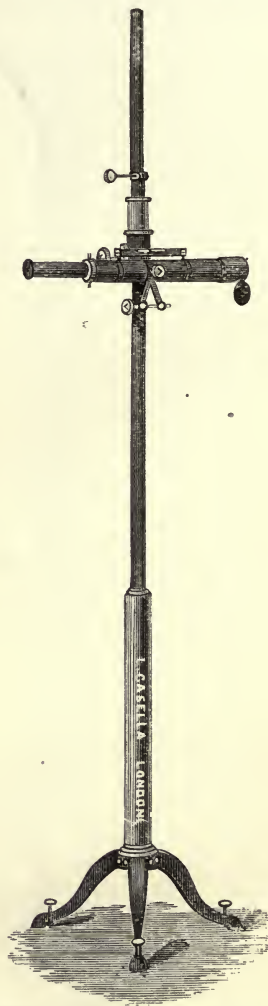

FIG. 42.—CATHETOMETER, 6½ FEET IN HEIGHT.

when the column is higher than the neutral point, subtracting it from the reading when it is lower than that point.

III. *Capillarity*.—It has been shown above that the effect of capillary action is always to depress the mercury in a barometer. The amount of depression is nearly inversely proportional to the diameter of the tube, and is always greater in unboiled than in boiled tubes.

The correction for capillarity is always additive (+), and according to the Report of the Committee of the Royal Society on Physics and Meteorology, 1840, it varies from +·004 inch in the case of an unboiled, and +·002 inch in that of a boiled tube of the diameter of ·60 inch, to +·142 inch in the case of an unboiled, and +·070 inch in that of a boiled tube of the diameter of ·10 inch.

The certificate of verification of a barometer issued from Kew Observatory includes the three corrections we have been considering as applicable to the individual instrument. Here is a copy of the certificate which accompanied the barometer in use at my own station of the Second Order :

Corrections to the Scale Readings of Barometer, 877, by Adie, London.

in. At 27·5	in. At 28·0	in. At 28·5	in. At 29·0	in. At 29·5	in. At 30·0	in. At 30·5	in. At 31·0
in. + 0·030	in. + 0·026	in. + 0·022	in. + 0·019	in. + 0·015	in. + 0·011	in. + 0·008	in. + 0·004

When the sign of the correction is +, the quantity is to be *added* to the observed reading; and when -, to be *subtracted* from it. The corrections given above include those for Index Error, Capacity, and Capillarity.

Pro B. STEWART,  
T. W. BAKER.

KEW OBSERVATORY, Jan. 7, 1867.

IV. *Temperature*.—Both the mercurial column and the brass scale of a barometer expand by heat, and so the height of the column varies with temperature. It therefore becomes necessary to reduce all observations to what they would have been at a given temperature, which is taken as a standard. This standard temperature is 32° F.

An elaborate table for reducing the readings of barometers,

mounted in brass frames to 32° F., has been computed from the following formula given by Schumacher :

$$\text{Correction} = -h \frac{m(t - 32^\circ) - s(t - 62^\circ)}{1 + m(t - 32^\circ)}, \text{ in which}$$

$h$  = reading of the barometer ;

$t$  = temperature of attached thermometer ;

$m$  = expansion of mercury for 1° F., taken as .0001001 of its length at 32° ;

$s$  = expansion of the substance of which the scale is made ;  
for brass  $s$ , is taken as .00001041 of its length ( $h$ ) at the standard temperature for the scale, viz., 62° F.

In this table the sign of the *correction* changes from + to - at the temperature of 29°, as the formula gives negative results for 3° below 32°.

V. *Altitude*.—Every barometrical observation should be reduced to mean sea-level as a standard, because as the barometer measures the pressure of the atmosphere, the height of its column will vary with that pressure, becoming less as we ascend and leave some of the atmosphere, and therefore some of its pressure, below us ; and, on the other hand, becoming greater as we descend and leave more of the atmosphere and more of its pressure above us. For Great Britain the mean sea-level at Liverpool has been selected by the Ordnance Survey as their datum, and the altitude of a barometer at any station in England, Scotland, or Wales may be easily determined by reference to the nearest Ordnance Bench Mark. The Ordnance Datum plane for Ireland differs from that for England and Wales by -7.4 feet—that for Ireland being low-water spring-tides, while that for England is mean tide-level. In order that observations in the two countries should be exactly comparable, the Meteorological Office, in 1890, issued new tables for use in Ireland in reducing barometrical readings to the Liverpool Ordnance Datum.

Any table of corrections for altitude or reduction to mean sea-level must take cognisance of two disturbing elements, the temperature of the air and the actual air-pressure at sea-level at the time of observation. The air temperature must be taken from the dry-bulb thermometer, not from the thermometer



attached to the barometer. Table II. in Appendix I. to *The Observer's Handbook*, published by the Meteorological Office, London, in 1908, being a new and revised edition of *Instructions in the Use of Meteorological Instruments*, compiled by direction of the Meteorological Council by Dr. Robert H. Scott, M.A., D.Sc., F.R.S., contains data for reducing to sea-level barometrical observations made at every 10 feet from 10 to 1,500 feet above the datum, and at temperatures varying by 10° from -20° F. to 100° F.—that is, a range of 120°. The table is given for two pressures at the lower or sea-level station—namely, 30 and 27 inches. For intermediate pressures the correction may be obtained by interpolating proportional parts.

For heights exceeding those given in the table, the value, at the sea-level, of a barometer reading at a station the height of which is known, may be calculated from the following formula :

$$\text{Log} \frac{h}{h'} = f \div \left\{ 60159 \left( 1 + \frac{t+t'-64}{900} \right) \left( 1 + .00268 \cos 2l \right) \left( 1 + \frac{f+52251}{20886861} \right) \right\}$$

From a table of common logarithms, the natural number corresponding to  $\log \frac{h}{h'}$  is found ; or  $\frac{h}{h'} = n$ ,

And  $h = n h'$ .

In this formula—

$h$  and  $h'$  = barometer reduced to 32° F. at the lower and upper stations respectively,

$t$  and  $t'$  = the temperature of the air at the respective stations,

$f$  = elevation of upper station in feet,

$l$  = latitude of the place.

The above formula is merely an inversion of the well-known formula given by Laplace in his *Mécanique Céleste*, for finding the difference of elevation between any two places by means of the barometer, which, adapted to Fahrenheit's thermometer and English feet and inches, is—

$$f = 60159 \log \frac{h}{h'} \left( 1 + \frac{t+t'-64}{900} \right) \left( 1 + .00268 \cos 2l \right) \left( 1 + \frac{f+52251}{20886861} + \frac{x}{10443430} \right)$$

In this formula  $f$  is the difference of elevation between the two stations, and  $x$  is the height of the lower station above the sea-level.

In the last factor an approximate value must be used for  $f$ .

Not only, then, can we reduce the barometer reading at one level to that at another, the relative heights of the two stations being known, but we can conversely determine the difference in height between two stations if we know the barometrical readings and the temperature at each at the same moment of time. In other words, we can determine the height of a mountain by barometrical readings taken simultaneously on the summit and at sea-level.

VI. *Gravity*.—Since the Earth is not a perfect sphere, but is slightly flattened at the poles, it follows that the centre, the seat of gravity, is more distant from the surface at the Equator than it is at the poles. Hence the force of gravity is less at the Equator than it is at the poles. The lessened force of gravity at the Equator has another cause also—namely, the centrifugal force arising from the rotation of the Earth on its axis. This acts in opposition to gravitation, and is necessarily greatest at the Equator, gradually lessening as we move northwards or southwards, till at the poles it is nothing.

The force of gravity accordingly varies slightly with the latitude, and hence barometric readings require to be reduced to a standard latitude in order to make them strictly comparable with one another in various parts of the world. The standard value of gravity adopted is that prevailing at latitude  $45^{\circ}$ .

The table in Appendix I., taken from *The Observer's Handbook*, published by the Meteorological Office, London, 1908, gives the correction for gravity required for each degree of latitude. It is to be added or subtracted according as the sign in the table is + or -. As the correction is practically constant for any one place—and, indeed, for all places in the same latitude—it is not as a rule applied to individual readings. It should, however, always be quoted at the head of tables of barometer readings.

## CHAPTER XIII

### BAROMETRICAL FLUCTUATIONS

ATMOSPHERIC pressure as measured by the barometer is subject to two classes of variations—*periodic* and *non-periodic*. The first are *regular* ; the second, *irregular*.

The regular or periodic variations are (1) *diurnal*, (2) *annual*.

The irregular or non-periodic variations are (1) *cyclonic*, (2) *anticyclonic*.

1. Diurnal variations are best marked within the tropics, or in the torrid zone. They are less marked in temperate climates, absolutely because their physical cause is there less potent, relatively because the irregular variations in atmospheric pressure so frequent in higher latitudes tend to mask them. They gradually sink to zero towards the Arctic and Antarctic Circles and the Poles. So regular is the daily rise and fall of the barometer in the tropics that Humboldt said that the time of day might be inferred from it within seventeen minutes.

As the earth rotates on its axis day by day, the hemisphere facing the sun becomes overheated, the air over it expands, becomes specifically lighter, rises, and tends to flow away from the day hemisphere to the night hemisphere. The barometer consequently falls in the hottest part of the day, reaching a minimum about 3 p.m. But a second, though less decided, minimum occurs about 3 a.m. This cannot be caused in the same way as the day minimum, for, as a matter of fact, the air is coldest about 3 or 4 a.m. We must therefore seek elsewhere for an explanation. It is to be found, according to Dove (and his theory received the sanction of Sabine), in the state of tension of aqueous vapour in the early morning. As we shall see when

we come to discuss the subject of the moisture of the atmosphere, barometrical pressure is made up of two elements—the pressure of dry air, and the pressure of aqueous vapour suspended in the atmosphere. This latter is technically called the elastic force, or tension, of aqueous vapour. Now, long before 3 a.m. dew has fallen heavily—in other words, the aqueous vapour has been condensed by the nightly fall of temperature, and has left the atmosphere in the condition of dried or desiccated air. In this way the tension of aqueous vapour is largely withdrawn, and the barometer falls.

As there are two minima of pressure, so there are two maxima. Of these, the first occurs about 10 a.m., the second about 10 p.m. Condensation of the air after a cold night partly accounts for the forenoon wave-crest of pressure. But another potent cause is rapid evaporation, and consequently increasing tension of aqueous vapour. The evening maximum is no doubt due to a brisk decrease of temperature, causing condensation of the atmosphere, coupled with the saturated state of the air after the evaporation of the daytime. The vapour tension, or elastic force, in a word attains *its* maximum.

The foregoing theory affords a rational explanation of these interesting diurnal fluctuations of pressure, and it receives support from the fact that at stations far distant from the sea, or with a high mean temperature—that is, at places where the diurnal ranges of temperature are least interfered with by large evaporating surfaces like the ocean or by moist winds—the maximum at 10 p.m. and the minimum at 3 a.m., which are largely due to the condition of the aqueous vapour, are only slightly marked.

Dove's theory, however, does not receive universal acceptance, because (in the words of Mr. R. Strachan, F.R.Met.Soc.<sup>1</sup>) “the diurnal range of vapour tension does not always and everywhere conform to the simple oscillation.” According to Mr. Strachan, in the Island of Ascension we still have a double period for the diurnal range of the barometer, but the vapour tension and the dry air pressure of which it is composed both exhibit a double period also. Such cases completely demolish the theory. Mr. Strachan adds: “A hypothesis then remains yet to be framed

<sup>1</sup> “The Barometer and its Uses,” *Modern Meteorology*, p. 89. 1879.



which shall account for the diurnal range of the barometer in all seasons and places.”

Be that as it may, the fact remains that every day of twenty-four hours sees two vast waves of high pressure and two equally vast troughs of low pressure sweep round the globe at a speed equal to the revolution of the earth on its axis. It is as if two solar tides, stupendous in extent, with their alternate ebb and flow, were generated in the atmosphere by the action of the sun, or, as Inspector-General Robert Lawson suggests, by alternate accelerations and retardations of the motion of the atmosphere revolving with the earth on its axis, caused by the relation which the atmosphere bears to the orbital motion of the earth as distinguished from its axial motion.

The *diurnal range* of pressure, as the difference between the extreme daily oscillations is called, exceeds  $\frac{1}{10}$  inch within the tropics—at Calcutta it is as great as .127 inch in January (dry north-east monsoon), but only .093 inch in July (moist south-west monsoon)—the average for the whole year being .116 inch. At Plymouth and in Dublin it is about .020 inch, or only one-sixth of the tropical value. In St. Petersburg it is .012 inch, and within the Arctic Circle it merges gradually into the *annual range*, owing to the length of the circumpolar day and night (Fig. 43).

From observations in Dublin, extending over as many as forty-five years, I am prepared to say that the diurnal range of pressure is quite perceptible in anticyclonic weather, especially in spring-time, when the air is dry and the diurnal range of temperature is large. It is doubtless even better marked at an inland station like Parsonstown or Armagh under like circumstances. Observations, carefully analysed by Mr. Francis Campbell Bayard, have shown that it increases steadily from north-west towards south-east over Western and Central Europe.

The following references to the recent bibliography of diurnal range of pressure may prove of interest. The papers will be found in the *Quarterly Journal of the Royal Meteorological Society*.

1. On the Diurnal Variations of the Barometer. By John Knox Laughton, M.A., F.R.A.S. (vol. ii., p. 155—read April 15, 1874).

2. The Diurnal Inequalities of the Barometer and Thermometer, as illustrated by the observations made at the summit and base of Mount Washington, N.H., during the month of May, 1872. By W. W. Rundell, F.M.S. (vol. ii., p. 217—read June 17, 1874).
3. On the Diurnal Variation of the Barometer at Zi-Ka-Wei (a suburb of Shanghai,  $31^{\circ} 15'$  north latitude), and Mean Atmospheric Pressure and Temperature at Shanghai. By Rev. Augustus M. Columbel, S.J. (vol. ii., p. 232—read June 17, 1874).
4. Suggestions on certain Variations, Annual and Diurnal, in the Relation of the Barometric Gradient to the Force of the Wind. By the Rev. W. Clement Ley, M.A., F.M.S. (vol. iii., p. 232—read June 21, 1876).
5. On the Diurnal Variation of the Barometer at the Royal Observatory, Greenwich. By William Ellis, F.R.A.S., of the Royal Observatory (vol. iii., p. 467—read June 20, 1877).
6. On a Method of sometimes determining the Amount of the Diurnal Variation of the Barometer on any particular Day. By the Hon. Ralph Abercromby, F.M.S. (vol. iv., p. 198—read June 19, 1878).
7. The Daily Inequality of the Barometer. By W. W. Rundell, F.M.S. (vol. v., p. 1—read May 15, 1879).
8. Diurnal Variations of the Barometric Pressure in the British Isles. By Frederick Chambers, Meteorological Reporter, Bombay (vol. v., p. 133—read February 19, 1879). See a paper by the same author in the *Philosophical Transactions of the Royal Society* for 1873—“Convection Current Theory.”
9. The Diurnal Range of Atmospheric Pressure. By Richard Strachan, F.M.S. (vol. vi., p. 42—read December 17, 1879).
10. Results of Hourly Readings derived from a Redier Barograph at Geldeston, Norfolk, for the four years ending February, 1886. By E. T. Dowson, F.R.Met.Soc. (vol. xiii., p. 21—read November 17, 1886).
11. On the Cause of the Diurnal Oscillation of the Barometer.

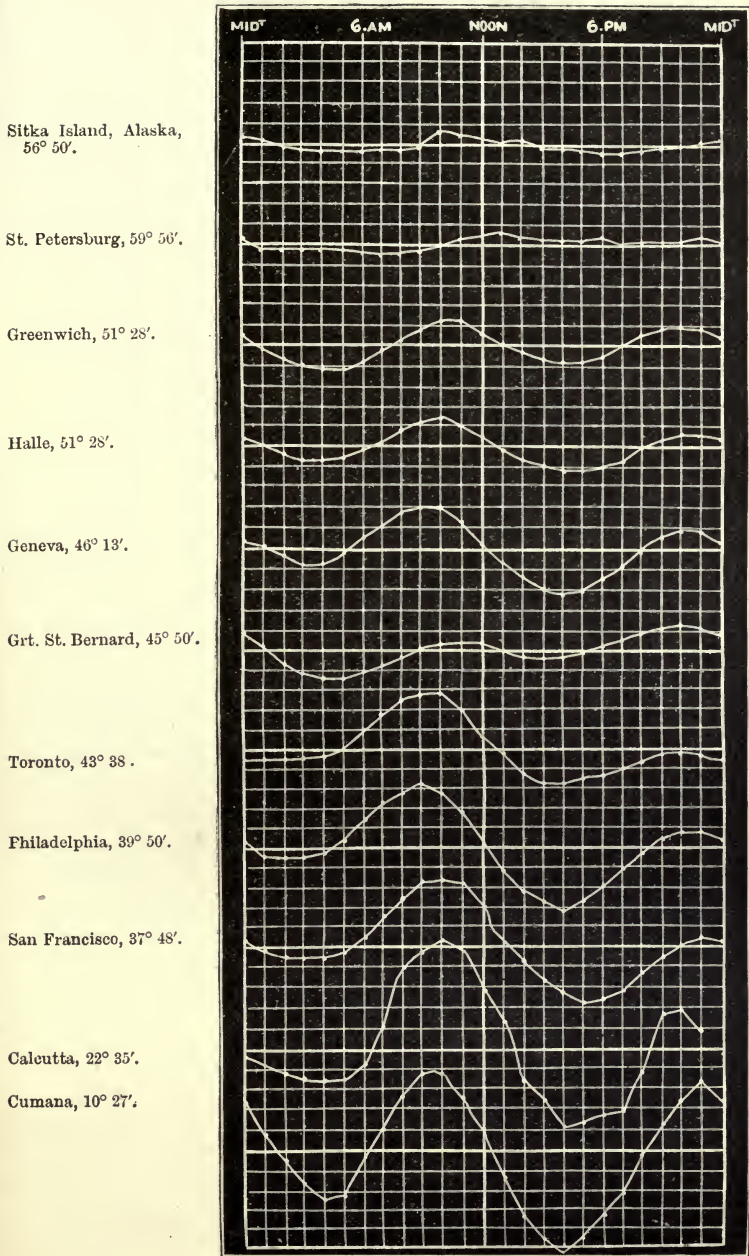

FIG. 43.—DIURNAL OSCILLATION OF THE BAROMETER IN VARIOUS LATITUDES.

NOTE.—The distance between each two horizontal lines represents 0.1 inch. Thus, at Sitka the reading at 10 a.m. is 0.008 inch above the mean.

By Robert Lawson, LL.D., Inspector-General of Hospitals (vol. xiv., p. 1—read November 16, 1887).

12. The Diurnal Range of the Barometer in Great Britain, and Ireland, derived from the Hourly Records of the Nine Principal Observatories in the Kingdom during the years 1876-80. By Francis Campbell Bayard, LL.M., F.R.Met.Soc. (vol. xv., p. 146—read April 17, 1889).
13. Diurnal Barometric Curves in Valleys. By Dr. A. Buchan (vol. xix., p. 60).
14. On Certain Relationships between the Diurnal Curves of Barometric Pressure and Vapour Tension at Kenilworth (Kimberley), South Africa. By J. R. Sutton, M.A., F.R.Met.Soc. (vol. xxx., p. 41—read December 16, 1903).

2. *Annual Variations* in atmospheric pressure are on a far vaster scale than the daily ranges we have been considering. As typical examples, we may adduce the high-pressure areas observed in January over the central districts of North America (30·20 to 30·30 inches) and over Central Asia (30·30 to 30·40 inches and upwards). These anticyclonic systems on a gigantic scale give place in July to equally well-marked low-pressure, or cyclonic, systems—the mean pressure falling over the central parts of North America to 29·80 inches and less, or  $\frac{1}{2}$  inch on the average below the mean pressure of January; and over Central Asia to 29·60 inches and less, or  $\frac{8}{10}$  inch below the January mean.

Again, compare the low-pressure areas of January situated over the Pacific Ocean south of Alaska (29·60 inches), and over the Atlantic Ocean south of Greenland and Iceland (29·40 inches), with the comparatively high mean pressures for July in these oceanic regions—29·90 to 30·00 inches over the Pacific, 29·80 to 29·90 inches over the Atlantic.

Let us seek for an explanation of these phenomena.

Over the centre of that vast continent of the Eastern Hemisphere, or Old World, which is formed by Europe and Asia, the air in summer becomes much warmer than that over the Atlantic Ocean to the west, and over the Pacific Ocean to the east. In consequence, the air is rarefied, and the barometer falls over



Russia, Siberia, and other inland countries—the isobars, or lines of equal barometrical pressure, curving round the area of lowest pressure—while it remains comparatively high over the North Atlantic and North Pacific Oceans. In accordance with Buys Ballot's Law, a circulation of wind will commence round the barometrical depression thus formed: an immense *cyclone* develops, the winds blowing against the hands of a watch, from south-west in India and China (the south-west monsoon); from south, south-east, and east in Japan and North-Eastern Siberia; from north-east and north in North-Western Siberia and Northern Russia; from north-west and west over the west and south of Europe and South-Western Asia.

In winter, on the other hand, the air over the central districts of Europe and Asia, rendered dry by the intense heat of summer and its accompanying excess of evaporation, becomes rapidly chilled to an extreme degree. The autumnal snows cover the ground, cutting off terrestrial radiation and causing a still more decided fall of temperature. By this the air is condensed and the barometer rises at a time when a vacuum is forming over the Atlantic and Pacific Oceans owing to the updraught and lateral dispersion of the light warm air which had been resting upon the surface of those oceans, and which may at the time possess a temperature  $60^{\circ}$  or even  $80^{\circ}$  higher than that of the air over the interior of the great Continent. Owing to the advancing season also, and the consequent general decrease of temperature, the air over these oceans becomes saturated with moisture, frequent rains result, and a further reduction of atmospheric pressure results, caused by the latent heat set free in the formation of rain. In this way conditions are brought about which are the reverse of those observed in summer: an immense anticyclone is formed, the winds circulating round and *out from* the centre of high pressure in a direction with the hands of a watch, blowing from north-west and north in Japan and China; from north-east in India (the north-east monsoon); from east and south-east in Russia and Southern Europe; from south-west in the British Isles; and from west in Northern Russia and Siberia. In Central Russia and Siberia a region of calms will exist near the position of the highest atmospheric pressure. In the winter season the predominant

winds over Scandinavia are south-easterly, but this apparent anomaly is in fact a beautiful fulfilment of the very laws it seems to contradict. We have seen that in winter a barometrical depression exists over the North Atlantic Ocean, particularly over that portion of it which is called the Norwegian Sea. It is this which draws the wind from south-east over Sweden and Norway, in strict agreement with Buys Ballot's Law.

A precisely similar state of things, though on a somewhat reduced scale, holds good in the Western Hemisphere, or New World. In summer a barometrical depression, or cyclonic system, develops over Upper Canada and the Central States of the Great Republic, round which minimum the prevailing winds sweep in a gentle curve against watch-hands. In winter, on the contrary, an area of high atmospheric pressure, or anti-cyclonic system, develops in the same region, and round its central zone of calms the prevailing winds blow with watch-hands. Hence the prevalent north-west and north winds, which bring to Labrador, Lower Canada, and the Eastern States the rigorous winters of the American Atlantic seaboard; although, of course, the setting of a polar current of iceberg-laden water southwards along that seaboard intensifies the rigours of the climate, just as the warm waters of the North Atlantic north-easterly surface-drift in laving the western shores of Europe temper the climate even further north than the Arctic Circle.

In the department of Cosmical Physics of Section A (Mathematics) at the meeting of the British Association, at Winnipeg, in August, 1909, Mr. R. F. Stupart, Director of the Canadian Meteorological Service, read a paper on the "Distribution of Atmospheric Pressure in Canada." The chief points of the paper were: (1) That the world charts of pressure distribution give an inadequate and even inaccurate representation of the pressure conditions in the Dominion; (2) that relatively high pressure in the North-West at Dawson City is accompanied by relatively mild winters and low pressure by severe winters, a fact which is directly contrary to the prevailing idea that in winter the higher the pressure the lower the temperature over continental areas.

In Equatorial regions, where air temperature and moisture are constants throughout the year, the annual variation in

atmospheric pressure is trifling in amount. In the southern hemisphere, however, seasonal changes in pressure again become marked, although they are not so pronounced as in the northern hemisphere, where dry land or continent so largely takes the place of ocean.

*Trade Winds.*—Leaving out of count the great disturbances of pressure from winter to summer and from summer to winter, caused by the rise and fall of temperature over the continents of the Old and New Worlds, we find that a belt or ridge of comparatively high pressure, from 30·00 to 30·20 inches, encircles the earth at the tropics both north and south of the equator, while over the Equator and the immediate vicinity to 10° or 15° north and south, the barometer stands from  $\frac{1}{10}$  to  $\frac{2}{10}$  inch lower. In the northern hemisphere this ridge lies approximately along latitude 35°. In the southern hemisphere it is situated about latitude 30°. These areas of high and relatively low pressure oscillate backwards and forwards with the season: in January the northern zone of high pressure approaches the Equator, while the corresponding southern zone recedes from it. Conversely, in July the northern zone retreats northwards, while the southern advances towards the Equator. In obedience to Buys Ballot's Law, permanent winds blow from these respective areas of high pressure towards the Equatorial trough of low pressure, constituting the North-East Trades of the Tropic of Cancer and the South-East Trades of the Tropic of Capricorn.

Dr. Alexander Buchan, in a masterly analysis of barometrical observations taken at some four hundred stations scattered all over the globe, has ascertained that atmospheric pressure is lowest throughout the year over the Antarctic Ocean, about 29 inches. "In the hemisphere where winter reigns, the greatest pressure lies over the land; the larger the continent, the greater the pressure. In the hemisphere where summer reigns the low pressures are over the land, the high over the oceans." Mr. R. Strachan, whose words we have just quoted, gives the following table of the most remarkable areas of high and low pressures (see p. 160).

So far periodical variations in atmospheric pressure have been our theme. We have now to consider those irregular variations

which daily, monthly, and yearly occasion changes in wind and weather over more or less extensive areas of the earth's surface. They are measured or determined by drawing lines of equal barometrical pressure, or isobars, on a map of the area under discussion, which is then called a synoptic weather chart. These

Period.	Position.	Pressure.
December, January, February ..	{ Iceland { 50° N. 170° W. { 50° N. 100° E. { 0° to 40° S.	Inches
		29·4
		29·6
		30·4
June, July, August .. ..	{ 40° N. 90° E. { 30° N. 40° W.	30·0
		29·5
		30·2

isobars are drawn for each  $\frac{1}{10}$  inch. They tend to assume two primary and five secondary shapes (Fig. 44). If they enclose an area of low pressure, forming a circle or an oval, they are described as *cyclonic* in shape, from the Greek κύκλος, a circle. If, on the contrary, the isobars encircle an area of high pressure,

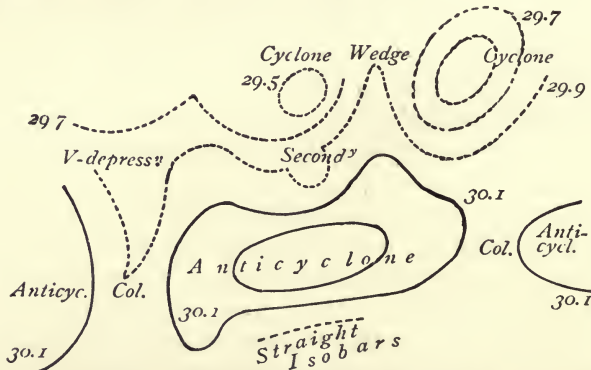

FIG. 44.—CYCLONIC AND ANTICYCLONIC ISOBARS.

they are described as *anticyclonic*, the Greek preposition ἀντι meaning originally *over against*, *opposite*—hence, *in opposition to*.

Thus we have two primary types of isobars—*cyclonic* and *anticyclonic*.

The secondary shapes are five in number. They are for the most part modifications of the primary types or connected with



either one or other of them. Thus, in a cyclonic system one or more of the isobars sometimes curves outwards from the centre, forming a loop which embraces a secondary area of low pressure in the periphery of the primary cyclone. Such a system is called in consequence a *secondary* or *subsidiary depression*.

Again, isobars embracing an area of relatively low pressure, instead of curving into a cyclone, run or bend into the shape of the letter V. Such a system is called a *V-shaped depression*.

Occasionally, in the third place, the isobars run parallel to each other, or nearly so, it may be for hundreds of miles, assuming the form neither of cyclonic nor of anticyclonic isobars. They are then called *straight isobars*.

In the fourth place, when cyclonic systems are following each other in rapid succession, and when an anticyclone is in the neighbourhood, a tongue of high pressure inserts itself like a wedge between two areas of low pressure. Such a system resembles an inverted V, but is the converse of a V-shaped depression, because its isobars enclose an area, not of low, but of high pressure. It is called a "*wedge*."

Lastly, two anticyclones may be connected with each other by means of a furrow or neck of relatively low or less high pressure, and this system is called a *col*, because it is analogous to the col which forms a pass between two adjacent mountain-peaks (Ralph Abercromby).

Speaking in general terms, we may contrast cyclonic with anticyclonic systems as follows :

1. Cyclonic areas in the northern hemisphere as a rule travel, it may be, at the rate of twenty miles an hour or upwards—in Equatorial regions from east to west, in extra-tropical latitudes usually from west to east. The "westing" of cyclonic systems generated between the Equator and the Tropic of Cancer is due to the general westward drift of the atmosphere throughout those low northern latitudes (N.E. trades). The area throughout which this occurs in the North Atlantic Ocean covers the Caribbean Sea and the region to the eastward of the Windward Islands. As the centres of low pressure draw away from the Equator until the northern limit of the N.E. trades is reached, the cyclonic path usually, but not always, recurves, and turns eastward and

towards the Pole. When this happens, the resulting storm loses the characteristics peculiar to tropical cyclonic storms, which are called "West India hurricanes" in the North Atlantic, and "typhoons" in the Pacific, off the coast of Asia.

Anticyclonic systems, on the contrary, are often stationary for days or weeks, or their motion is slow and irregular. They frequently move away from the track of cyclonic systems almost at right angles. Occasionally a shallow depression forms within the confines of an anticyclone, and dull, rainy weather ensues, with much haze or fog.

2. In cyclonic systems the isobars generally approach each other much more closely than do those of anticyclones—in other words, the gradients are steeper, and therefore the winds are stronger in cyclones than in anticyclones.

3. Unsettled, windy, rainy, or showery weather is commonly associated with cyclonic systems. In anticyclones, on the contrary, conditions are as a rule fine, quiet, and dry. In winter, however, dense fogs sometimes accompany the calms of an anticyclone, and in parts of its periphery the sky may be densely clouded. If rain should fall, it is usually drizzling—not heavy. In summer, hot sunshine by day and cool nights accompany an anticyclone, and sea-fogs are prevalent when the calm-centre overlies the sea. In any case much haze obscures the horizon.

4. Thunderstorms are very apt to develop in connection with V-shaped and secondary depressions. In the former, violent shifts of wind and sudden changes of temperature usually occur, these phenomena being accompanied by heavy squalls and showers of rain and hail, or, in winter, snow.

5. The weather accompanying anticyclones is well described by the Hon. Ralph Abercromby as "radiation weather"—hot suns by day and cool nights in summer; intense frost in winter, so long as the sky is tolerably clear.

6. The term "*intensity*" applied to an anticyclone means that the barometer has reached an unusual height in its centre; further, that the system is of vast extent and also of long duration. The same term applied to a cyclonic system means that the isobars are close together, and that the system is deep and moving quickly. "There is no difference," says the Hon. Ralph

Abercromby,<sup>1</sup> "between the cyclones which cause storms and those which cause ordinary weather except *intensity*."

The great majority of the atmospheric depressions which pass over the British Islands come in from the Atlantic, and travel most usually in a north-easterly, less frequently in an easterly or south-easterly, direction. Their advent, passage, and departure are attended by definite changes in the weather. First, in front of the disturbance, the sky becomes streaked with cirrus cloud, which spreads out into a thin veil of cirriform cloud or cirro-stratus, in which solar or lunar halos develop, and through which is seen a "watery sun" or a "watery moon," as the case may be. The wind freshens from south-east, the cloud canopy thickens, and a stratum of lower clouds of the scud-cumulus type develops, coming up from south-east or south under the cirriform sheet, which is probably travelling from west or south-west. Drizzling rain next sets in, and finally heavier driving rain and squalls from the southward. As the lowest pressure is reached, the wind may fall calm if the centre of the system is near at hand. Then more or less suddenly and completely the wind shifts to west or north-west, with dense clouds, heavy rain or showers of rain and hail, and a brisk fall of temperature. The clouds now break, and massive cumuli drive past across a deep blue sky, sharp showers probably falling at intervals in the rear of the disturbance.

In the case we have been supposing, the depression or cyclonic system is travelling north-eastwards. It is to be noted that the wind is said to "veer," or "haul," when it changes *with the sun*; for example, when it changes from east to south-east, south, or south-west, or from south to west or north-west, or from north-west to north-east, and so on. Should it change *against the sun*, it is said to "back," and when it changes completely in direction, as from east to west or south to north, it is said to "shift."

On rare occasions depressions move slowly westwards or north-westwards from the Continent of Europe towards the British Islands. The western or north-western quadrant of the depression is then its *front*, and the weather varies accordingly, being "muggy," cloudy, and damp or wet.

<sup>1</sup> *Weather*, p. 29. London: Kegan Paul, Trench and Co. 1887.

In anticyclones barometrical gradients are comparatively slight, and the force of the wind is correspondingly moderate as a rule. During winter intense cold prevails in the centre and in the south-east and south-west quadrants of the anticyclone; in its north-west and north-east quadrants—at least, in Western Europe—conditions are milder. A typical instance of such a distribution of temperature occurred in the memorable frost of 1890-91. An anticyclone hung for weeks over Central Europe and the southern half of the British Islands. Intense cold prevailed in these districts, while the west of Ireland, the greater part of Scotland, and Scandinavia, came under the influence of warm south-west and west winds skirting the north-west and north-east quadrants of the anticyclone. The result was that in the extreme north of Scotland, as well as in the west of Ireland, the mean temperature for fifty-nine days (November 25, 1890, to January 22, 1891) was  $10^{\circ}$  higher than in the south-east of England. The mean temperature for the period was  $10^{\circ}$  or more below the average over the southern Midlands and south of England. In the north of England the deficiency, however, did not amount to  $5^{\circ}$ , and in the extreme north of Scotland it was less than  $1^{\circ}$ . At Sumburgh Head, in the Shetlands, frost occurred on only nine of the fifty-nine days, whereas at Biarritz it occurred on thirty-one days, and at Rome on nine days. At Brussels it froze daily throughout the period. On January 19, 1891, the harbour at Toulon was reported to be frozen over for the first time on record, while the ice floating on the Thames between London Bridge and the Tower was so packed that all movements of vessels had entirely ceased. On January 20, the River Tagus at Lisbon was frozen over, and the Ebro was covered with 19 inches of ice, the first since 1829. In Regent's Park skating lasted forty-three days consecutively (December 13, 1890, to January 24, 1891), according to Colonel Wheatley, R.E., of the Office of Works.

Anticyclonic weather in summer is characterised by dry, quiet, bright weather, hot suns by day being followed by cool nights, except in the north-west quadrant of the system, where the nights are warm and often cloudy.



## CHAPTER XIV

### THE ATMOSPHERE OF AQUEOUS VAPOUR

At the close of Chapter III., on the Composition of the Atmosphere, it was pointed out that one of its most important constituents was aqueous vapour, or water in a gaseous or aeriform state. Moisture is universally present in the atmosphere, but in very variable proportions as regards both time and place. To its elastic force or tension the height of the barometer is to some extent due, and we might with propriety speak of two atmospheres instead of one atmosphere—the atmosphere of aqueous vapour as well as the atmosphere of dry air. No other factor singly exercises so profound, so far-reaching an influence on weather as the aqueous vapour of the atmosphere. Its liability to alter its form from the gaseous to the liquid or solid state and back again, the caloric phenomena which accompany these changes, and the extreme variability in amount of vapour present in the air,—these all cause frequent fluctuations in temperature and pressure, in cloud and sunshine, in terrestrial and solar radiation, in wind and weather.

Watery vapour is constantly distilling into the atmosphere from the surface of oceans, lakes, and rivers, and from the moist soil. In general the tiny molecules, which make up the vapour, are invisible as they rise into the atmosphere to diffuse freely through the air and to float about in the interstices between the atoms of oxygen and nitrogen which compose the atmosphere. If, however, the aerial strata are much colder than the water surface upon which they rest, the evaporating water may appear instantly as steam or fog. This is one cause of winter fogs in the vicinity of large rivers like the Thames. On a frosty day such a river may be seen to literally *steam* into the atmosphere—the

aqueous vapour being condensed as soon as it has separated from the water by evaporation. The fact is, that only a certain quantity of aqueous vapour can diffuse through the air in an invisible form, and that the quantity which can so diffuse varies with the temperature of the air. The warmer the air, the greater the quantity of vapour which it can sustain in an invisible state. The colder the air, the smaller the quantity of vapour it can so sustain. Setting out from 32° F., at which the air can sustain  $\frac{1}{180}$  of its weight of transparent vapour, we find that for every increase of temperature of 27° the vapour-sustaining capacity of air is doubled. Thus, at 59°, air can sustain the  $\frac{1}{80}$ th part of its own weight of vapour, and at 86° the  $\frac{1}{40}$ th part. Each cubic foot of saturated air at 32° F. contains only 2·37 grains of aqueous vapour; at 60° it contains 5·87 grains; and at 80°, 10·81 grains. It follows from this that, if the atmosphere is suddenly chilled from 80° to 60°, nearly 5 grains of vapour will be condensed out of every cubic foot of air, forming mist or cloud and falling as rain. This is really the explanation of one of the most potent causes of rain.

It is evident that aqueous vapour, while constantly present in the atmosphere, is equally constantly passing into it by evaporation and passing out of it by condensation. The subject, therefore, naturally falls under three headings, which are well given by Dr. R. H. Scott, F.R.S., in his *Elementary Meteorology*, as follows :

“ 1. *Atmometry*, or the determination of the amount of water passing into the air by evaporation.

“ 2. *Hygrometry*, or the determination of the amount of water present in the air in the vaporous form.

“ 3. *Hyetometry*, or the determination of the amount of water condensed out of the atmosphere in the form of [dew], [hoar-frost], rain, hail, or snow.”

#### ATMIDOMETRY.

Evaporation is the process by which water is changed from the liquid or solid (ice or snow) state into vapour, and is carried off into the atmosphere as such. Atmometry, or, more correctly, atmidometry (Greek, ἀτμός or ἀτμός, *steam* or *vapour*; μέτρον, *a measure*), is the determination of the amount of evaporation by

means of instruments which are indifferently called evaporimeters, atmometers, or atmidometers. Evaporation takes place most quickly into dry air at a high or increasing temperature. It is also facilitated by high wind, and to some extent by low barometrical pressure. In Western Europe the process is most active in spring, when the capacity for moisture of the atmosphere is increasing owing to the prevalence of desiccated easterly winds, whose temperature is fast rising. On the other hand, in late autumn (November) evaporation is usually almost at a standstill, because the temperature of the air is falling fast, and its capacity for moisture is diminishing, so that it is charged with vapour, or *saturated*. When this last condition is present, evaporation ceases and the slightest additional fall of temperature would cause condensation into fog, cloud, or rain.

In evaporating, every grain of water absorbs heat sufficient to raise 960 grains of water through 1° of Fahrenheit's scale. This heat is extracted from neighbouring objects, and is made *latent*—that is, it *lies hid* or *concealed* in the vapour, ready to be used again in the converse process of condensation. Latent heat can no longer excite a sensation of warmth, or be measured by the thermometer. It is, however, existent, and is employed in keeping the vaporous molecules "floating loosely and widely apart" (R. J. Mann).

The coolness produced by evaporation has been utilised in hot climates in many ways. Porous earthenware jars are employed to cool drinking-water, and in India railway carriages are cooled by placing damp matting across the windows, while ice is formed by exposing water in shallow pans, laid on straw, to the combined effects of evaporation and radiation at night.

From data which were collected some years ago by the late Rev. Samuel Haughton, M.D., F.R.S., Senior Fellow of Trinity College, Dublin,<sup>1</sup> it would seem that in nearly all parts of the globe, situated reasonably near the coast, the rainfall is about equal to the evaporation from a *free water surface*, and that there can be no great transference of vapour from the torrid to the temperate zones (R. H. Scott).

<sup>1</sup> *Six Lectures on Physical Geography*, p. 165. London: Longmans, Green and Co. 1880.

Even at the present day no entirely satisfactory atmometer or evaporimeter exists.<sup>1</sup>

On November 24, 1859, Dr. Babington, F.R.S., exhibited to the Royal Society the evaporimeter which now bears the name of "Babington's atmometer." It consists of an oblong hollow bulb of glass or copper, beneath which, and communicating with it by a contracted neck, is a second globular bulb, duly weighted with mercury or shot. The upper bulb is surmounted by a small glass or metal stem, having a scale graduated to grains and half-grains, on the top of which is fixed a shallow metal pan. The bulbs are immersed in a vessel of water having a circular hole in the cover, through which the stem rises. Distilled water is poured into the pan above until the zero of the stem sinks to a level with the cover of the vessel. As the water in the pan evaporates, the stem ascends, and the amount of the evaporation is indicated in grains.

In Professor von Lamont's atmometer the evaporation pan is a shallow cylinder with a slightly curved bottom, from the middle of which a narrow pipe leads to a vertical cylindrical reservoir of water, containing a closely-fitting piston. The position of this piston in the cylinder is adjustable by means of a screw which moves the piston vertically, and it can be read by a vertical scale attached to the piston, a pointer being carried by the cylinder. The method of observing is as follows: The

<sup>1</sup> The reader who is interested in the subject will find articles on evaporation, in which exhaustive descriptions of the principal instruments in use for measuring evaporation are given, in: (1) *Symons's British Rainfall*, p. 151. 1869. (2) *Symons's Monthly Meteorological Magazine*, pp. 70-74. 1870. (3) *Ibid.*, pp. 156-159. 1876. (4) *Ibid.*, p. 2. 1887. (5) *Symons's British Rainfall*, pp. 18-43. 1889. (6) *Ibid.*, pp. 17-29. 1890. (7) *Quarterly Journal of the Royal Meteorological Society*, vol. xvii., pp. 186, 187. No. 79. July, 1891. (8) "Records of Evaporation" in the yearly volumes of *British Rainfall*. (9) "Measurement of Evaporation," by Richard Strachan F.R. Met. Soc., *Quarterly Journal of the Royal Meteorological Society*, vol. xxxi., No. 136. October, 1905, p. 277. (10) "Description of the Wilson Radio-integrator," *British Rainfall*, 1907, p. 44. (11) "Methods and Apparatus for the Observation and Study of Evaporation," by C. F. Marvin, Professor of Meteorology. *Monthly Weather Review*, April and May, 1909. U.S. Department of Agriculture, Weather Bureau. (12) "Studies on the Phenomena of the Evaporation of Water over Lakes and Reservoirs," by Professor Frank H. Bigelow. *Ibid.*, July, 1907, February, 1908. Annual Summary, 1908. (13) "An Annotated Bibliography of Evaporation," by Mrs. Grace J. Livingston (from A.D. 1670 to the present day). *Ibid.*, June, September, November, 1908; February, March, April, May, 1909.



piston is screwed up so as to allow the water in the evaporation pan to run into the reservoir, leaving the connecting tube quite full, so that the water just makes the curved surface of the bottom of the pan continuous. The scale is then read, and the water is driven by the piston up to within a little of the top of the pan, and the evaporation is allowed to take place. The piston is then raised, so that the water sinks again from the pan to the same point as before, and the scale is read again. The difference of readings in scale divisions gives the depths of water evaporated.

A manifest fault in these instruments is the exposure of the water in the evaporation-dish to gusts of wind at all seasons, causing waste; and to frost in winter, stopping their mechanical movements.

In de la Rue's evaporimeter the water evaporates from a surface of moistened parchment paper, stretched over a shallow drum kept full of water, which is supplied from a cylindrical reservoir giving about 6 inches head. Into this vessel dips a narrow metal tube, forming the only opening into a graduated cylinder of glass about 6 inches high and  $1\frac{1}{2}$  inches in diameter. The glass cylinder is in the first instance filled with water, and the tube leading from it, which dips into the reservoir, is perforated laterally. The water in the reservoir is therefore maintained at a constant level by a flow of water from the glass cylinder whenever the lateral opening becomes exposed to the air. The amount of water evaporated is given by the graduations on the glass cylinder, which are so drawn as to express the evaporation in hundredths of an inch.

A self-recording evaporation gauge was exhibited by MM. Richard Frères, of Paris, at the Twelfth Annual Exhibition of Instruments held by the Royal Meteorological Society in March, 1891. It consists of a pair of scales, one of which bears a basin of water or a plant. Weights are placed in the opposite scale to establish a state of equilibrium. A style is attached to the scale beam, and the pen records its motions on a revolving drum. The sensitiveness of the scale is regulated by a sliding weight, which being raised or lowered, raises or lowers the centre of gravity of the scale beam.

Mr. Spencer P. Pickering, M.A., F.R.S., invented and patented

an instrument which affords a simple means of measuring directly the volume of water evaporated from a moist surface of known area. In "Pickering's Patent Standard Evaporimeter," the moist surface consists of a piece of linen (originally of a sheet of blotting-paper) measuring 100 millimetres by 50 millimetres, held vertically, by means of a hinged frame, over a copper water-reservoir fitted with a graduated glass side-tube, as shown in the figure (Fig. 45). The sheet of linen ends in a tongue which dips into soft, distilled, or rain water, and is thus kept damp. The graduations are such that they give the number of units of volume

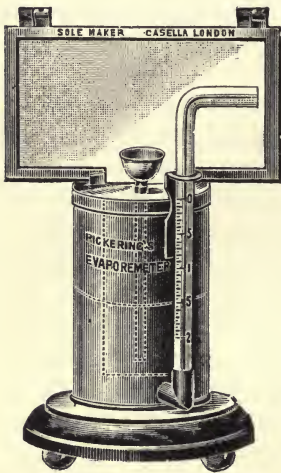

FIG. 45.—PICKERING'S STANDARD EVAPORIMETER.

evaporated per unit area exposed. Thus a fall of  $\cdot 24$  shows that  $\cdot 24$  cubic inch, or cubic centimetre, has evaporated from each square inch, or square centimetre, of the surface exposed.

In *British Rainfall* the late Mr. G. J. Symons, F.R.S., each year, from 1885 inclusive, published a return of the evaporation from a water surface at his residence, Camden Square, London, N.W. He kept a daily record of the depth of water evaporated from the surface of a tank 6 feet  $\times$  6 feet  $\times$  2 feet, buried 20 inches in the ground, and in which water to a depth of about 22 inches was usually kept. The average annual evaporation from this water surface in the years 1885-91 was 14.5 inches. Evaporation in London is greatest in June and July, least in December and January. This record has been continued year by year since Mr. Symons's death by his successor, Dr. Hugh Robert Mill. The monthly average evaporation at Camden Square in the twenty-two years, 1885-1906 inclusive, and the monthly evaporation in 1907 were as follow :

	Jan.	Feb.	Mar.	April.	May.	June.	July.	Aug.	Sept.	Oct.	Nov.	Dec.	Total.
Average ...	in. .09	in. .26	in. .67	in. 1.52	in. 2.35	in. 2.94	in. 3.18	in. 2.39	in. 1.35	in. .62	in. .23	in. .08	in. 15.68
1907 ...	.21	.38	1.02	1.27	1.93	2.47	2.65	2.24	1.72	.49	.27	.19	14.84
Difference	+ .12	+ .12	+ .35	-.25	-.42	-.47	-.53	-.15	.37	-.13	+ .04	+ .11	-.84

For many years the late Mr. James Price, M.Eng., Univ. Dublin, C.E., of Knockeevin, Greystones, County Wicklow, kept evaporation gauges in connection with rain gauges in Dublin, and at Cavan, Sligo, Galway, and Athlone. Several reliable series of observations of great interest were obtained. For instance, during two consecutive years the evaporation in Dublin and at Galway was 26 inches, whereas in the County Cavan only 13 inches of water passed off into vapour. This showed that the habitual dampness of the air was exactly twice as great in Cavan as in Galway or Dublin. In Cavan there is a retentive sticky clay subsoil, with endless lakes and a less wind-movement than on the coast at Galway, which also has a dry gravelly subsoil, with but little stagnant water. The dampness is independent of the rainfall, which is heavier at Galway than in Cavan; nor does it depend so much on the contiguity of the sea as on the nature of the subsoil and the amount of stagnant fresh water in the district. Mr. Price pointed out that there is something particularly bracing and invigorating in the air of those parts of Galway and Clare where a gravelly subsoil occurs. Indeed, he was so strongly of opinion that habitual dryness of the air as indicated by evaporation gauges has more to do with health than the matter of rainfall, that he suggested that each locality should have its evaporation gauges as well as its rain gauges. To make the results of observations on evaporation comparable, Mr. Price recommended that the water level in the evaporation gauge should be kept at a given standard, and he stated that he had devised a plan whereby this can be accomplished automatically.

At a meeting of the Royal Meteorological Society held on Wednesday, April 21, 1909, Mr. Baldwin Latham, M.Inst.C.E., read a paper on "Percolation, Evaporation, and Condensation," in which he gave the results of the observations which he had carried out at Croydon on the subjects during the last thirty years. Two percolation gauges were used, both of which were exactly a superficial yard in area, and contained a cubic yard of natural soil, one of chalk and the other of gravel. The average annual amount of percolation through the chalk gauge was 10·84 inches, and through the gravel gauge 10·34 inches. The average annual rainfall was 25·456 inches. It appears that the rate of percolation

is governed by the rate of rainfall, for when once the gauges have become sensitive by being thoroughly wetted, the rate at which rain percolates depends entirely on the quantity of rain immediately falling. The evaporator used for determining the evaporation was a floating copper vessel 1 foot in diameter, supported by a life-buoy ring, connected by four arms with the evaporating vessel, the whole being floated in a tank 4 feet internal diameter, containing about 3 feet depth of water. The average annual amount of evaporation by this gauge was 18.137 inches, and the average annual amount of what has been termed "negative evaporation" or really condensation was .359 inch.

Mention was made at p. 34 of the Barton Moss Evaporation Station near Southport, Lancashire. At this station the standard evaporation tank is one of Symons's pattern, 6 feet square and 2 feet deep, and its rim is 3 inches above the ground. The height of the water is measured daily, at 9 a.m., by means of a Halliwell Float and Multiplying Index-Finger Gauge. The amount of evaporation is entered to the previous day, as is also the rainfall. A second evaporation tank, only 3 feet square, but in all other respects similar to the standard one just described, is in use for comparative purposes.

The rain-gauge is of the Snowdon pattern, 5 inches in diameter. Its rim is 9 inches above the ground.

The table on p. 173 is taken from Mr. Joseph Baxendell's Meteorological Report to the Southport Corporation for 1908. Barton Moss is only 14 feet above mean sea-level.

This table shows very clearly how deficient is the evaporation throughout the winter months, how rapidly it increases in spring, how it exceeds the rainfall in early summer, and how quickly it lessens from August to November.

It is to the United States of America that we must look for investigations into the subject of evaporation on a large scale. In May, 1907, the Salton Sea, Southern California, consisted of a sheet of fresh water, 45 miles long, and about 10 or 15 miles wide, containing 440 square miles of surface area, 205 feet below the mean tide-level of the Pacific Ocean. This body of water had recently been formed by an overflow from the Colorado River, and was protected from further inflow. It was estimated that



this lake would probably dry out in ten or twelve years, so that an unusually fine example of evaporation on a large scale in the arid climate of Southern California was offered for study.

Preliminary observations were undertaken in July, August, and September, 1907, at Reno, Nevada, a district lying to the east of the Sierra Nevada Mountains, which is very favourable for excessive evaporation, without the discomfort of abnormally high summer temperatures, such as occur in the Salton Basin. The expedition to Reno was furnished with some improved apparatus designed by Professor C. F. Marvin, U.S. Weather

TABLE V.—EVAPORATION AND RAINFALL AT BARTON MOSS, LANCASHIRE.

1908.	Evaporation per 6-foot Tank.		Rainfall.
	Total Evaporation.	Difference from the Average.	
	Inches.	Inches.	Inches.
January .. ..	.31	- .10	2.11
February .. ..	.68	+ .21	2.33
March .. ..	1.09	- .25	2.48
April .. ..	2.32	+ .04	2.50
May .. ..	3.04	+ .05	2.59
June .. ..	3.27	- .34	1.65
July .. ..	3.27	- .40	3.14
August .. ..	3.09	- .10	3.33
September .. ..	1.69	- .35	3.76
October .. ..	1.05	- .17	2.23
November .. ..	.57	+ .01	2.45
December .. ..	.57	+ .18	2.65
Totals .. ..	20.95	- 1.22	31.22

Bureau ; Mr. Lynam T. Briggs, U.S. Department of Agriculture ; and Mr. Edgar Buckingham, Bureau of Standards. The instruments in question included a measuring micrometer for differential changes in the level of a water surface, an electrical device for maintaining a fixed surface-level and measuring the cubic contents of evaporated water, an improved Piche evaporimeter, an anemometer transformed for reading wind velocities in kilometres per hour instead of miles per hour. Evaporating pans and auxiliary contrivances, such as towers for the equipotential surfaces, tubes for the Stefan formula, and so on, were constructed at Reno.

For details as to the results of the experiments reference must be made to Professor Frank H. Bigelow's reports in the *Monthly Weather Review* of the U.S. Weather Bureau for July, 1907, February, 1908, and the "Annual Summary" of the same publication for 1908. In the *Monthly Weather Review*, April and May, 1909, also, Professor C. F. Marvin describes the methods and apparatus which were employed, and which should be employed in investigations on evaporation. His monograph is a model of scientific writing, and is fully illustrated.

## CHAPTER XV

### THE ATMOSPHERE OF AQUEOUS VAPOUR (*continued*)

#### HYGROMETRY.

HYGROMETRY is on a more satisfactory basis than atmidometry. Hygrometers (Greek, *ὕγρὸς*, moist; *μέτρον*, a measure) are of two kinds—direct and indirect, and the latter class is further subdivided into organic and inorganic—organic hygrometers being those which depend for their indications on the effects produced on such organic substances as wool, twine, hair, and seaweed, by the varying humidity of the atmosphere.

All direct hygrometers experimentally illustrate the theory or principle of the *dew-point*—that critical temperature at which dew begins to be deposited. We have seen that the capacity of the atmosphere for taking up and holding aqueous vapour in suspension varies with the temperature; in other words, with the elastic force or tension of aqueous vapour. If temperature falls, and with it the tension of vapour, a point is at last reached at which the air is saturated with moisture. Should the chilling process be continued, a deposition of dew takes place—the temperature has fallen below the dew-point. Now, in a direct hygrometer the cooling process is continued until a film of condensed moisture, or “dew,” develops on a surface of polished metal or of glass. At this moment an attached thermometer is read off, giving the temperature of the dew-point.

Three *direct hygrometers* call for description—Daniell’s, Regnault’s, and Dines’s.

Professor Daniell, F.R.S., in 1820 described the instrument which bears his name (Fig. 46). It consists of a glass tube, bent twice at a right angle, and terminating at each end in a glass ball

or bulb. One of these bulbs is blackened, the other is covered with a jacket of fine linen or muslin. The black bulb is partly filled with pure ether, and encloses the bulb of a delicate thermometer, which just touches the surface of the ether. The bent tube and the other bulb are filled with ether vapour, all the air having been carefully removed. When it is desired to find the dew-point, a little ether is allowed to drop on the muslin or linen jacket of the other bulb. It volatilises quickly, and in so doing makes a large quantity of heat latent. In consequence of this, the ether vapour in the covered bulb condenses, and owing to reduced pressure the ether in the black bulb begins to evaporate. This process, in its turn, chills the black bulb so that a ring of dew begins to form upon its exterior. At this instant the contained thermometer is read off, and the dew-point temperature is ascertained.

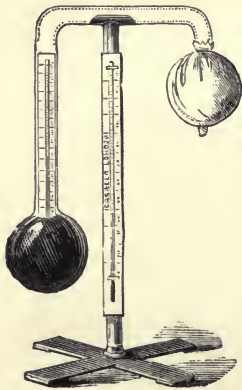

FIG. 46.—DANIELL'S  
HYGROMETER.

Regnault's direct hygrometer (Fig. 47) is a modification of Daniell's. In it there are two thermometers: one shows the temperature of the air; the other dips through a stopper into a small vessel or thimble of polished silver, and is exposed during an

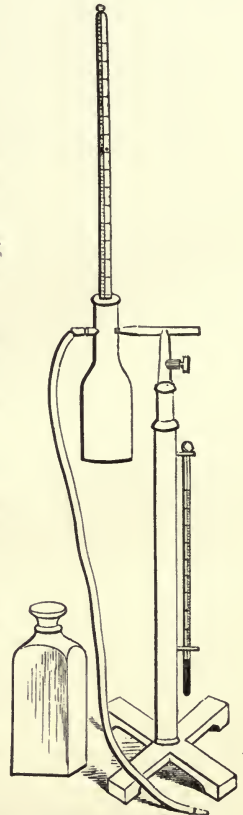

FIG. 47.—REGNAULT'S  
HYGROMETER.

experiment to the influence of a current of air bubbling through ether contained in the silver vessel. The observer creates the current of air by opening the tap of an aspirator or jar containing rather less than a gallon of water. As the water flows out of this



jar, it draws or aspirates air through a flexible tube connected by air-tight fittings with the silver thimble. To supply the place of the air thus drawn off, a fresh supply bubbles through the ether, drawn from the outer air through a small silver tube which is carried almost to the bottom of the silver thimble. As the air bubbles through the ether it causes it to volatilise, and in this way the temperature is so much reduced that dew is at last deposited on the outside of the polished silver vessel. The temperature indicated at this instant by the contained thermometer is that of the dew-point. In a modified form of the instrument, the observers blow gently into the silver thimble, and the waste

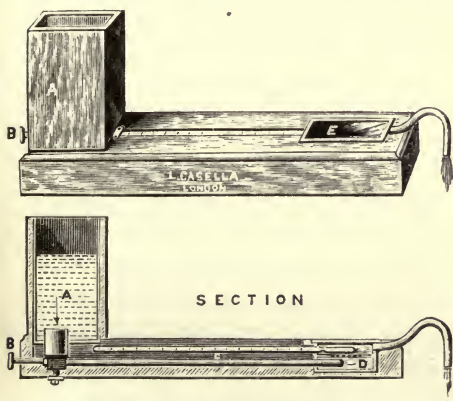

FIG. 48.—DINES'S HYGROMETER.

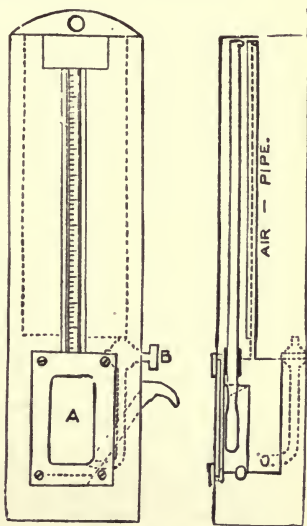

FIG. 49.—VERTICAL VIEW OF DINES'S HYGROMETER.

air is carried off from the silver bottle through a hollow bent tube, conducted into a hollow telescopic stand, which supports the whole apparatus.

The hygrometer (Figs. 48 and 49), designed by the late Mr. George Dines, F.M.S., is of simple construction, "consisting," says Dr. R. H. Scott,<sup>1</sup> "of a vase, A, fitted with a pipe at the bottom, which is conducted close under a plate of black glass, where it also envelops the bulb of a thermometer, C; a cock, B, is fitted at the base of the vase. Very cold water, or ice and water, is put into the vase, and the cock is opened; the glass speedily

<sup>1</sup> *Elementary Meteorology*, p. 104.

becomes dulled, and the thermometer is read. The cock is then closed again, the water in the tube soon rises in temperature, and the cloud disappears, the moment of its disappearance being that when the dew-point is again reached. The operation may be repeated as long as the water in the vase remains at a temperature below the dew-point."

*An Electrical Dew-point Hygrometer.*—At the Southport Meeting of the British Association for the Advancement of Science in 1903, Professor F. T. Trouton, F.R.S., exhibited a modified Dines's hygrometer under this title. The moment of deposition of moisture on a hygrometer of the Dines's type is observed from the completion of an electric circuit effected by the deposited moisture. Two long parallel wires are affixed to the surface of deposition. These wires form the electrodes of a circuit containing a battery and indicating instrument. While the circuit is dry there is insulation, but on dew forming, the current can pass between the wires. The apparatus can be adapted for use with an automatic recording instrument for giving a record of the dew-point at frequent intervals. It is also of use in positions where the moment of deposition of dew cannot be observed by the eye.

*Indirect Hygrometers.*—Many fibrous organic bodies tend to alter their molecular arrangement, or their appearance, when exposed to damp. In the hair hygrometer of de Saussure advantage is taken of this tendency. A hair elongates when damp, and contracts when dry. In de Saussure's hygrometer a healthy human hair, freed from grease by careful boiling in an alkaline fluid, fixed at one end, is turned round a pulley, and supports a light weight. Connected with the pulley is an index hand or needle, which moves over a graduated scale, thus roughly showing the percentage humidity of the air, or the hygrometric state or degree of saturation of the air. Strictly speaking, de Saussure's hygrometer is merely a hygroscopic (Greek, *ὕγρός*, moist; *σκοπέω*, I look at), or an instrument which shows whether the air is moist or dry, without measuring the amount of moisture.

Among inorganic indirect hygrometers, mention should be made, in the first place, of two chemical hygrometers: one, a scientific toy; the other, an exact method of chemical analysis. The former is the toy ballet-dancer, a French invention, in which

a change of colour of the dress from pink to red occurs when the weather becomes damp. The dress is stained with a solution of the nitrate or chloride of cobalt, which salts are hygroscopic in the way described. In the chemical hygrometer a known volume of air is made to pass by aspiration through weighed tubes packed with chloride of calcium, which has a singular affinity for moisture, and so desiccates the aspirated air. After the experiment the tubes are again carefully weighed, and the increased weight represents the amount of watery vapour present in the given volume of air.

Professor F. T. Trouton showed at Southport, in 1903, a gravimetric recording hygrometer. The principle on which the working of this instrument depends is that the weight of moisture condensed by bodies such as flannel is, within the meteorological range of temperature, approximately a function of the hygrometric state alone. Thus, when the moisture in the air varies, or the temperature changes, the weight absorbed by a piece of flannel also changes; not, however, in proportion to the amount of moisture present, but in proportion to the hygrometric state. This alteration in weight is shown by the movement of the arm of a balance from which the flannel is suspended, and is recorded by means of an inked stilus, on graduated paper, revolving with a clock-driven drum.

*The Aquameter.*<sup>1</sup>—Mr. William B. Newton, Ph.D., F.C.S., F.I.C., described to the Royal Meteorological Society, on November 15, 1905, a quick method of determining exactly the amount of moisture in the air by means of an instrument to which he has given this barbarous name.

The instrument consists simply of a mercury reservoir connected by a rubber tube to a measured glass tube with two taps. While the top tap is open, by raising the reservoir the mercury is put up to the mark 100. On lowering the reservoir till the mercury in the measured tube drops to mark 0, 100 measures of air are drawn in (in the case of the present instrument 100 cubic centimetres). The top tap is then closed.

The tap in the side tube at the top of the measuring vessel

<sup>1</sup> *Quarterly Journal of the Royal Meteorological Society*, vol. xxxii., p. 11, 1906.

is then opened, connecting a small glass bulb containing porous granular phosphoric anhydride. This absorbs the aqueous vapour of the 100 measures of air. On then bringing the mercury in the reservoir and that in the measured tube to the same level (thus giving the air in the measured tube the atmospheric pressure at which it came in), the rise of the mercury above 0 in the measured tube is the exact percentage by volume of the aqueous vapour previously in the air. With an additional tap and bulb containing solid caustic potash the carbonic acid gas in the air can also be determined in the same manner. The additional reading of the scale to that shown after the aqueous vapour is absorbed gives the carbonic acid in parts per ten thousand.

Before commencing the experiment the top tap is closed, and the taps to the two bulbs are opened in order to remove the aqueous vapour and carbonic acid in the air of the vessel above the mark 100.

To cause rapid absorption of the aqueous vapour during the experiment, the reservoir of mercury is raised so as to press as much air as possible into the absorbing flask containing the phosphoric anhydride.

The absorption then takes place in about five minutes, but it is safer to give the instrument ten minutes so as to be certain of complete absorption before taking the reading.

As the time taken by the experiment is short, there is no need to make allowance for change of temperature. Practically there is no change of temperature in so short a time, unless the position of the instrument is moved.

The indicator for showing when the surfaces of the two columns of mercury are level is a horizontal brass bar, which is moved up or down close to the mercury tubes. This horizontal bar slides on two brass uprights.

When the saturation point is passed, for instance in misty weather, the instrument does not register the total moisture. It does not measure any moisture existing as liquid drops, but it records accurately at all atmospheric temperatures so long as the moisture in the air exists as aqueous vapour.

In 1792 Hutton observed that a thermometer read lower if



its bulb was wet. But it is to Sir John Leslie of Edinburgh, and to Mason of London, that we really owe the *psychrometer* (Greek,  $\psiυχρός$ , *cold* or *chill*;  $μέτρον$ , *a measure*), or the dry and wet bulb hygrometer. This apparatus, which is now (often under the name of "Mason's Hygrometer") everywhere employed in hygrometrical observations, consists of two carefully graduated thermometers, placed side by side at a distance of some 4 inches (Fig. 50). One of these thermometers marks the air temperature, and is called the "Dry Bulb." Round the bulb of the other a muslin cap is lightly tied, and this is kept moist with water drawn from a small reservoir by means of capillary attraction through a few strands of loosely twisted lamp-wick. As the moisture evaporates from this muslin cap, heat is made latent, and the temperature of the wet-bulb thermometer is depressed *in proportion to the amount and rapidity of evaporation*. From the respective readings of the dry- and wet-bulb thermometers many valuable deductions may be made: for example, the dew-point, the tension or elastic force of vapour (or the amount of barometric pressure due to the vapour in the air), the relative humidity, the weight of vapour in a cubic foot of air, the amount of vapour required to saturate the air, the weight of a cubic foot of air in grains at the prevailing atmospheric pressure.

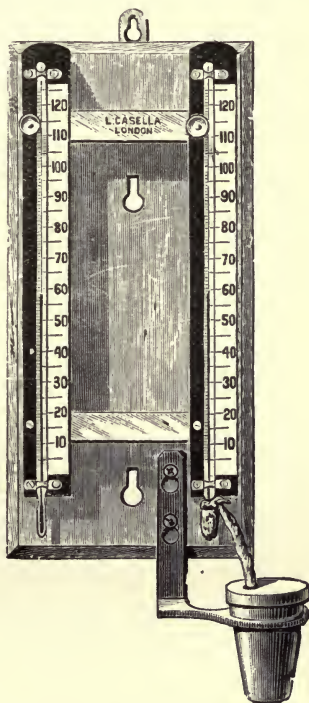

FIG. 50.—MASON'S HYGROMETER.

At Vienna, in 1873, the International Meteorological Conference concluded that the psychrometer (wet and dry-bulb thermometer) cannot be replaced by any other instrument, though its defects are not to be denied.

Many years ago, August in Germany, and Professor James Apjohn, M.D., of Trinity College, Dublin, independently investigated a method of determining, by calculation, the maximal vapour tension for the dew-point from the temperatures of the dry and wet-bulb thermometers. August's researches will be found in *Poggendorff's Annalen* for 1825 and 1828. In 1834 and 1835 Dr. Apjohn laid his investigations before the Royal Irish Academy. They are published in the *Philosophical Magazine* for 1835, and in the *Trans. R.I.A.* for 1837 (vol. xvii., p. 277).

The physical principle assumed by both investigators is precisely the same. Dr. Apjohn states it as follows :

“When in the moist-bulb hygrometer the stationary temperature is attained, the caloric which vaporises the water is necessarily exactly equal to that which the air imparts in descending from the temperature of the atmosphere to that of the moistened bulb ; and the air which has undergone this reduction becomes saturated with moisture.”

Let  $f$  = tension of aqueous vapour at the dew-point temperature which we desire to know.

$f'$  = tension of vapour at the temperature of evaporation, as shown by the wet-bulb thermometer.

The values of  $f$  and  $f'$  for every degree of temperature from  $0^{\circ}$  F. to  $95^{\circ}$  F. are known from experiments carefully performed by M. Regnault.

Further, let  $a$  = the specific heat of air.

$e$  = the latent heat of aqueous vapour.

$(t - t')$  or  $d$  = the difference between the reading of the dry-bulb thermometer and that of the wet bulb.

$p$  = the pressure of the air in inches ; then Dr. Apjohn's formula is—

$$f = f' - \frac{48a(t-t')}{e} \times \frac{p-f'}{30}$$

or, with the coefficient—

$$f = f' - 0.01147(t-t') \times \frac{p-f'}{30}.$$

This formula, for wet-bulb temperatures above  $32^{\circ}$ , works out thus :  $f = f' - \frac{(t-t')}{87} \times \frac{h}{30}$ ,  $h$  being the height of the barometer, substituted for  $(p - f')$ .

The fraction  $\frac{p-f'}{30}$  usually does not differ much from unity at stations near the sea-level (R. H. Scott).

Consequently, the formula is abbreviated into—

$$f=f' - \frac{t-t'}{87}, \text{ or } f=f' - \frac{d}{87}.$$

For temperatures of the wet bulb below 32°, the value is—

$$f=f' - \frac{t-t'}{96}, \text{ or } f=f' - \frac{d}{96}.$$

Mr. James Glaisher, F.R.S., by instituting a series of comparisons between synchronous observations of the dry and wet bulb thermometers and of Daniell's hygrometer, made at Greenwich from 1841 to 1854, and also at high temperatures in India, and at low and medium temperatures at Toronto, constructed special tables, based on a series of numbers called the Greenwich Factors, by means of which the dew-point and other hygrometrical results may be ascertained by inspection. Glaisher's Hygrometrical Tables, as they are called, have passed through many editions, and are now almost universally employed by practical meteorologists for the purpose of deducing the dew-point, vapour tension, and relative humidity (saturation = 100), from observations of the dry- and wet-bulb thermometers. A copy of these useful Hygrometrical Tables is supplied to each observer by the Meteorological Committee, constituted in 1905, and a further simplification of them by Mr. William Marriott, F.R.Met.Soc., will be found in *Hints to Meteorological Observers*, prepared by him under the direction of the Council of the Royal Meteorological Society.

Although these "shorts cuts" exist, it may be interesting to explain the use of Glaisher's factors by which the dew-point is found.

From the dry-bulb reading subtract the wet-bulb reading, multiply the difference by the factor corresponding to the dry-bulb reading, and subtract the product from the dry-bulb reading. The result is the dew-point.

For example—

Dry bulb = 53°.  
Wet bulb = 49°.

Then,

53° - 49° = 4° × 2.00 (the factor corresponding to 53°) = 8,  
53° - 8° = 45° = the dew-point temperature sought for.

A table of Glaisher's Factors will be found in Appendix II.

To ascertain the dew-point is of practical importance from a health standpoint as well as in agriculture and horticulture. As Dr. Buchan observes:<sup>1</sup> "It indicates the point near which the descent of the temperature of the air during the night will be arrested." "Thus, then," he adds, "the dew-point determines the minimum temperature of the night." The moment the dew-point is reached, dew is deposited and latent heat is given out, causing temperature to rise. After a time, the air is by radiation again cooled down to the dew-point, when the same process is repeated through the night—the air temperature gently oscillating round the dew-point, so long as the sky is clear and the air tolerably calm.

Having once found the dew-point, we can determine the percentage of saturation or the *relative humidity*, provided we have before us a table of the tension or elastic force of aqueous vapour at ordinary temperatures.

Assuming the dry-bulb temperature as above to be 53°, and that of the dew-point to be 45°, we enter Table II. (Appendix II.) and extract the tension at 53°—namely, .403 inch, as well as that at 45°—namely, .299 inch. If the air were saturated with moisture, the tension would be .403 inch, but it is only .299 inch. From these facts the percentage of saturation—that is, the *relative humidity*—is easily calculated by simple proportion—100 being taken to represent saturation and 0 absolutely dry air—

$$\cdot 403 : \cdot 299 :: 100 : x = 74\cdot 2 \text{ per cent.}$$

If from the tension of aqueous vapour at the dry-bulb temperature we subtract that at the dew-point, we obtain the force of evaporation. Thus, in the example we have chosen,  $\cdot 403 - \cdot 299 = \cdot 104$  inch.

In order to avoid erroneous deductions from observations made with the dry- and wet-bulb thermometers, it is necessary to keep the wet bulb in working order by frequent douching of the muslin covering and the capillary threads connecting it with the cistern or reservoir. Soft river water, or rain water,

<sup>1</sup> *Introductory Text-Book of Meteorology*, p. 96. William Blackwood and Sons. 1871.



or distilled water should be used for this purpose. If spring water or hard lime-waters are used, their calcareous salts are deposited in the meshes of the muslin and the strands of lamp-wick or floss-silk leading to the cistern, capillary attraction is interrupted, the muslin dries, and evaporation ceases.

In frost, it is a matter of great difficulty to keep the wet bulb acting. In the first place, so long as the water surrounding it is actually freezing, its temperature will remain steadily at  $32^{\circ}$ , although the dry bulb may be some degrees lower. This is brought about by the disengagement of latent heat during the process of freezing. Again, when the wet bulb and its connections are thoroughly frozen, capillary action between the cistern and the bulb will cease, the ice about the bulb will soon evaporate, and the wet bulb will no longer indicate the temperature of evaporation. In such a contingency, the muslin covering of the bulb must be damped with ice-cold water by means of a small wet camel's hair brush about half an hour before the time of observation. In Russia the use of the hair hygrometer has been enjoined in winter, at the instance especially of M. Pernter.

The "depression" of the wet-bulb thermometer below the dry-bulb reading depends in some measure on the ventilation to which the instruments are exposed. In calm weather the observer may reduce the temperature of the wet-bulb thermometer by a degree or upwards by fanning the instrument. In balloon ascents a relative calm is produced by the balloon travelling with the wind. In order to get trustworthy wet-bulb readings during such ascents, Professor Assmann has devised the "ventilated psychrometer." This instrument consists of dry- and wet-bulb thermometers mounted in parallel metal tubes which communicate at their upper ends. A small ventilating fan, driven by clock-work, is placed in the upper end of the tube. By this means an air current of definite velocity can be aspirated past the thermometers whenever readings are required, and in this way comparable results may be obtained.<sup>1</sup>

From experiments carried out in Spitzbergen, M. Ekholm, of Upsala University, deduced the law that  $45^{\circ}$  C. must be subtracted from the reading of the wet-bulb thermometer when it

<sup>1</sup> *The Observer's Handbook*, Meteorological Office, p. 33. 1908.

is covered with ice before the figures given in Jelinek's Psychrometer Tables can be applied. The physical cause of the unduly high reading of the wet bulb is due to the difference between the saturation pressure of water vapour over water and over ice.

Aqueous vapour is most abundant in the atmosphere near extensive water surfaces. It is very deficient in the centres of continents, and rapidly diminishes in amount as we ascend through the atmosphere. Dr. R. H. Scott says that it has been calculated that one-half the quantity of vapour in the air is contained in the lowest 6,000 feet of the atmosphere, and that the amount contained in the air above 20,000 feet is only one-tenth part of that at the surface of the ground. Hence the burning power of the sun in the arid atmosphere of lofty mountain peaks and slopes. Tyndall<sup>1</sup> well observes that a sheet of vapour acts as a screen to the earth, being in a great measure impervious to heat. When the air is laden with moisture, visible or invisible, the intensity of the sun's rays is controlled by day and terrestrial radiation is checked by night. It is at the same time, perhaps, necessary to explain that moderate heat with a damp atmosphere is singularly oppressive, but this arises from another cause than actual elevation of temperature, and that is interference with evaporation. The air being well-nigh saturated, evaporation is checked, and its cooling and beneficial influence is in consequence unfelt.

The tension or elastic force of aqueous vapour represents the pressure of all the vapour in the air above the place of observation. It is expressed in terms of inches of the barometrical column, and represents the *absolute humidity* of the atmosphere. It is greatest near the Equator, least near the poles; greater over the ocean than over dry land, in summer than in winter, by day than by night, at sea-level than in the upper strata of the atmosphere.

"A Contribution to the History of Hygrometers" was the title of a Presidential Address delivered before the British Meteorological Society on March 16, 1881, by the late Mr. G. J. Symons, F.R.S. It will repay perusal, and is to be found in the *Quarterly Journal of the Meteorological Society*, July, 1881 (vol. vii., p. 161).

<sup>1</sup> *Heat, a Mode of Motion*, p. 385. London: Longmans, Green and Co., 1880.

The dew-point instruments described in the preceding pages are not suited for use in the open air except in calm weather. When the air is still, the layer immediately in contact with the cooled metallic surface may no doubt be in thermal equilibrium with the latter, even though it is surrounded by layers of warmer air, since air is a bad conductor; but in a fresh breeze the constant renewal of the air prevents its attaining the dew-point, unless the instrument is cooled to a considerably lower temperature. On this account these hygrometers, when used in the open air, give results which do not agree with those of the chemical hygrometer, and are even very discordant amongst themselves. The hygrometer invented by M. Crova avoids this defect, and affords very consistent indications.

*Crova's Hygrometer.*—In 1883 M. A. Crova, Professor in the University of Montpellier, invented an instrument, which is described in the late Dr. Thomas Preston's *Theory of Heat*, the second edition of which was published by Macmillan and Co., London, in 1904, and edited by J. Rogerson Cotter, M.A., Univ. Dubl. The original description of the instrument will be found in *Mémoires de l'Académie des Sciences et Lettres de Montpellier* (tome x., p. 411, 1883).<sup>1</sup>

The following description is taken from the second edition of Thomas Preston's *Theory of Heat* (Section 231), and is reproduced here, together with the three accompanying figures, by permission of Messrs. Macmillan and Co., Ltd. :

“ Fig. 51 (see p. 188) gives a general view of the instrument, a section of which is shown in Fig. 52 (see p. 188); *efgh* is a tube of thin brass, nickel-plated inside, and carefully polished. The end *ef* is closed by a disc of ground glass, which is illuminated by daylight or by a lamp, and which is viewed through a lens *gh*, which closes the other end of the tube. The image of the window *ef*, seen by reflection in the polished sides of the tube, appears as an annular ring of light *ee'ff'* of three times the diameter of *ef* (Fig. 53, p. 188).

“ Air can be slowly drawn through the brass tube by com-

<sup>1</sup> *Sur l'Hygrométrie.* Par M. A. Crova, Professeur à la Faculté des Sciences de Montpellier. *Extrait des Mémoires de l'Académie des Sciences et Lettres de Montpellier.* (Section des Sciences. Tome x., 1883.) Montpellier : Boehm et Fils. 1883.

pressing and slowly releasing the indiarubber ball (Fig. 51), and if the tube is cooled to the dew-point, the deposition of dew is immediately indicated by the darkening of the reflected image of *ef*.

“In order to regulate the temperature of the tube, the latter

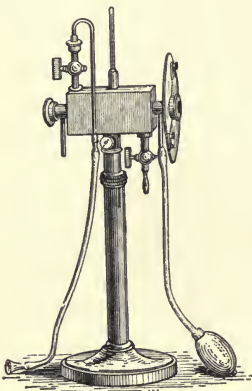

FIG. 51.—CROVA'S HYGROMETER.

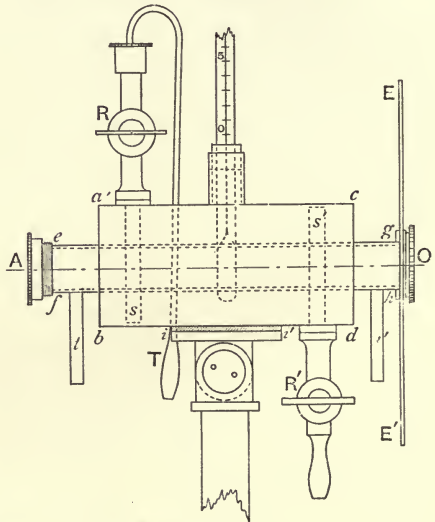

FIG. 52.—SECTIONAL VIEW OF CROVA'S HYGROMETER

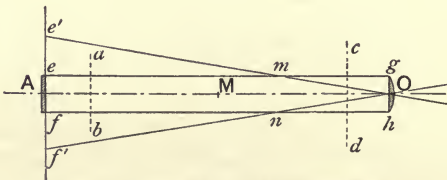

FIG. 53.—LENS IN CROVA'S HYGROMETER.

is surrounded by a brass box *abcd* containing bisulphide of carbon, through which air can be blown from the mouth by means of a rubber tube fitted to the tubulare T. M. Crova prefers carbon bisulphide to ether, because it is more readily obtained pure, and also does not boil in hot weather. Ordinary commercial ether contains water and alcohol, which are left behind when the ether



evaporates. But it is possible to attain a lower temperature with ether than with carbon bisulphide. A thermometer graduated in fifths of a degree dips into the liquid, and is in contact with the brass tube. A blackened screen *EE'* protects the eye from external light; *ii'* is a rubber disc insulating the brass box from its stand, through which heat might otherwise be conducted.

“The advantage of this hygrometer is that the whole of an enclosed volume of air is cooled to the temperature of the dew-point, and that it is unaffected by draughts. By attaching a long tube to the opening *t*, the air experimented on can be drawn from a point out of reach of the influence of the observer or of contamination by the vapour of carbon bisulphide. It can easily be regulated so that the appearance and disappearance of dew are within  $0.1^{\circ}$  C. of each other.”

## CHAPTER XVI

### THE ATMOSPHERE OF AQUEOUS VAPOUR (*continued*)

#### HYETOMETRY.

TAKEN in a practical rather than a strictly etymological sense, the word *hyetometry* (Greek, *ὑετός*, *rain*; *μέτρον*, *a measure*) may be extended in meaning so as to embrace all the different ways in which aqueous vapour is condensed out of the atmosphere and again restored to the earth from which it was originally taken up by evaporation.

Condensation of the watery vapour of the atmosphere takes place under *seven* different forms—(1) dew; (2) hoar frost; (3) mist and fog; (4) cloud; (5) rain; (6) hail; (7) snow. We shall consider each of these in more or less detail.

*Dew.*—The origin of dew attracted the attention of physicists towards the close of the eighteenth century, and the names of Pictet of Geneva, Le Roy of Montpellier, Six of Canterbury, and Patrick Wilson of Glasgow, are especially connected with the subject. But it is to Dr. Charles William Wells, a London physician, that we are indebted for a clear explanation of the nature of dew. He published in 1814 his celebrated *Essay on Dew*, and his theory of dew has ever since been generally accepted.

Dew is moisture deposited from the atmosphere under a clear sky in the colder hours, and therefore particularly at night. As the sun sinks in the western sky and finally sets, solar radiation, of course, becomes less and finally ceases. But simultaneously, provided the sky is clear and the atmosphere is tolerably dry and calm, terrestrial radiation increases, causing a rapid fall of temperature, so that at last the dew-point is reached. The moment temperature falls below this point, dew is deposited first and chiefly on those substances which are the best and therefore the most powerful radiators of heat. Such are hair, wool,

straw, grass, and herbage in general. There are really two kinds of dew, and in French they are distinguished by separate words—*serein* and *rosée*. *Serein* is the falling evening dew, which results from the general chilling of the stratum of air nearest the earth's surface after sundown. *Rosée* is the dew seen in the morning gathered in drops on the surface of leaves and other cool surfaces, and at the extremities of blades of grass; it is the morning dew, and its deposition depends on the more rapid radiation from the substances on which it gathers. This causes the moisture of the air which comes into contact with the leaves or grass to be condensed and to form drops of dew upon their surface.

This theory of dew has been called in question by at least one eminent physicist. In a lecture on the "Formation of Dew," delivered in 1897, Dr. J. G. McPherson, F.R.S.E., Lecturer on Meteorology in the University of St. Andrews, strongly supports the view originally put forward by Mr. John Aitken that what is really dew mostly rises from the ground. It is watery vapour rising from the soil and condensed by ascending into a chilled stratum of air resting upon the surface of the ground on a clear, calm night. According to this view, dew does not fall from the air, but rises from the soil. The glistening "dew-drops" on blades of grass and the leaves of plants are not really dew at all, but the watery juices of the grasses and plants themselves carried to the edges of the blade or leaf by its veins in order to keep up plant circulation. "The large drops seen on plants at night are falsely called dew; they are produced from the plants themselves as tokens of their active and healthy growth."<sup>1</sup> Dr. McPherson finds the most practically convincing proof of the rising of dew from the ground in the formation of hoar-frost or frozen dew.

*Hoar frost*.—In winter, should the dew-point be below 32°, hoar frost instead of dew is deposited, even forest trees assuming a thick coating of rime. This is to be distinguished from a phenomenon which occurs at the beginning of a sudden thaw after a severe frost, and which is called "silver thaw" (German, *Rauh frost*; French, *givre*), a deposition of rough ice-crystals on a surface still below the freezing-point. A smooth ice-coating formed under like

<sup>1</sup> *Symons's Meteorological Magazine*, vol. xxxii., p. 52. 1897.

circumstances is called "glazed frost" (German, *Glatteis*; French, *verglas*). When a warm, damp air comes into contact with frozen surfaces, its moisture is condensed and deposited in a solid form like hoar frost or light snow. Should rain fall on such surfaces, it is at once converted into a sheet of ice, which renders city pavements and country roads equally impassable for the time being. Glazed frost sometimes inflicts great injury on trees and plants. Dr. R. H. Scott quotes a remarkable example of the phenomenon which occurred in France in January, 1879, and was described by M. Godefroy in the eighty-ninth volume of the *Comptes Rendus* of the French Academy (p. 999). During a severe frost it rained heavily, but the rain instantly was congealed on contact with still frozen surfaces, so that branches of trees snapped off, and even the trees themselves were felled by the weight of superincumbent ice. A twig of a lime-tree, 4 inches long, weighed 930 grains, but when freed from ice only 7·5 grains. A laurel leaf carried a coating of ice which weighed 1,120 grains. These figures sufficiently explain the destructive action of a glazed frost.

The formation of dew is interfered with by (1) a high wind; (2) a very damp atmosphere even with a cloudless sky, because aqueous vapour checks terrestrial radiation; (3) a cloudy sky, which radiates back the heat cast off by terrestrial radiation; (4) the proximity of buildings or of lofty trees.

The most systematic attempt to measure the amount of dew which has been yet made was by the late Mr. George Dines, F.M.S.<sup>1</sup> His observations numbered 198, and were carried out in 1877 and 1878 near his residence at Walton-on-Thames, on open grass land, at a height of 52 feet above Ordnance Datum. On only three occasions was an amount of dew exceeding ·010 inch in depth deposited upon his measuring glasses. Taking the average of all his observations, and multiplying the result by 365, the annual *depth* of dew would appear to be 1·397 inches. If the observations on the grass only are taken, the amount is 1·022 inches. Mr. Dines considered that it might fairly be assumed that the average annual deposit of dew upon the surface of the earth falls short of 1·5 inches.

<sup>1</sup> *Quarterly Journal of the Meteorological Society*, vol. v., p. 157. 1879.



*Mist and-Fog.*—Possibly the simplest way to describe these phenomena is to say that they are really cloud formations in contact with, or suspended just above, the surface of the ground or ocean. Mist is, in the strict sense of the term, visible watery particles suspended in the atmosphere at or near the surface of the earth. In an applied sense it is coarser watery particles assuming the form of tiny rain-drops, and so floating in the air or falling to the ground. Such is the proverbial *Scotch Mist*.

Fog differs from cloud only in being near or in contact with the ground, and from mist only in regard to the fineness of the watery particles of which it is made up. It is to be remembered, however, that, in winter especially, dry smoke-fog often forms over large cities, notably over London and Manchester. Nothing is more remarkable than the property of fog to conduct sounds of all kinds to unwonted distances. Fog and mist are, strictly speaking, not aqueous vapour at all, but water itself in minutest particles or droplets. In the formation of fog and mist, aqueous vapour is condensed and latent heat is set free. These two facts establish the nature of fog and mist—they are water, not watery vapour. When objects exposed to their influence are moistened, or when an appreciable amount of water is collected in the rain-gauge during fog and mist, we speak of a “wet fog.”

In a Presidential Address to the Royal Meteorological Society on January 16, 1889, Dr. William Marcet, F.R.S., classifies fogs into sea fogs, lake fogs, river fogs, waterfall or spray clouds, and town fogs. This interesting address is published in the *Quarterly Journal* of the Society for April, 1889 (vol. xv., p. 59).

It is to the scientific researches of Mr. John Aitken, F.R.S.E., of Falkirk, N.B., that we are especially indebted for our knowledge of the formation of fogs, clouds, and rain. It was in the autumn of 1875, when studying the action of “free surfaces” in water when changing from one state to another, that Mr. Aitken first observed the conditions necessary for cloudy condensation.<sup>1</sup> By a “free surface” is meant a surface at which water is *free to change its condition*. For instance, the surface of a piece of ice in water is a “free surface” at which the ice may change to water,

<sup>1</sup> “On Dust, Fogs, and Clouds.” By John Aitken, F.R.S.E. *Trans. Royal Soc. Edin.*, vol. xxx., part i., p. 337. 1883.

or the water change to ice. Again, a surface of water bounded by its own vapour is a "free surface," at which the water may vaporise, or vapour condense. What are called the "freezing-point" and the "boiling-point" of water are the temperatures,  $0^{\circ}$  C. and  $100^{\circ}$  C. respectively, at which these changes take place at such "free surfaces." When there is no "free surface" in the water, we have at present no knowledge whatever as to the temperature at which these changes will take place. It is well known that water may be cooled in the absence of "free surfaces" far below the "freezing-point" without becoming solid. Several years ago Mr. Aitken showed reason for believing that ice, in the absence of "free surfaces," could be heated to a temperature above the "freezing-point" without melting.<sup>1</sup> Professor Thomas Carnelley, of Firth College, Sheffield, has shown this to be possible, and states that he has succeeded in raising the temperature of ice to  $180^{\circ}$  C.<sup>2</sup> Further, Mr. Aitken has shown in the paper above referred to, that if water be deprived of all "free surfaces" it may be heated in metal vessels while under atmospheric pressure to a temperature far above the "boiling-point," when it passes into vapour with explosive violence.

From the foregoing considerations it is evident that a necessary condition for water changing its state is the presence of a "free surface," or "free surfaces," at which the change can take place.

Let us now look, with Mr. Aitken, at the process, as it goes on in nature, of water changing from its gaseous or vaporous to its liquid state—in other words, to the cloudy condensation of our atmosphere.

"As the heat of the sun increases," writes Mr. Aitken,<sup>3</sup> "and the temperature of the earth rises, more and more water becomes evaporated from its surface, and passes from its liquid form to its invisible gaseous condition; and so long as the temperature continues to increase, more and more vapour is added to the air. This increased amount of vapour in hot air compared to cold air is generally explained by saying that hot air dissolves more water than cold air. This, however, is not the case. Air has no solvent action whatever on water vapour. Water vapour

<sup>1</sup> *Trans. Royal Scottish Society of Arts*, 1874-75.

<sup>2</sup> *Nature*, vol. xxii., p. 435. 1880.

<sup>3</sup> "On Dust, Fogs, and Clouds," *Trans. Royal Soc. Edin.*, p. 337.

rises into air to the same amount that it would do into a vacuum at the same temperature, only it rises into air more slowly than into a vacuum, and the amount of vapour which can remain in the air is independent of the amount of air present—that is, independent of the pressure of the air—and depends only on the temperature.

“After air has become what is called ‘saturated’ with vapour,—that is, when the vapour tension is that due to the temperature—a momentary condition of stability is attained. Suppose the temperature to fall, a change must now take place. All the water cannot remain as invisible vapour; some of it must condense out into its visible form. It is this condensed water held in mechanical suspension in the air to which we give the names of fog, cloud, mist, and rain—phenomena having some resemblance to each other, yet possessing marked differences. The particles composing a fog, for instance, are so fine they scarcely fall through the air, a cloud is a little coarser in the grain, while a mist is coarser still in texture, and rain is any of these while falling, whether it be a wetting mist or a drenching rain. And the question now comes, Why this difference? Why should the water vapour condense out of the air in one case in particles so minute they seem to have no weight, and remain suspended in the air, while in another case they are large-grained and fall rapidly?”

The key to the answer to this question is given by a very simple and beautiful experiment, which I had the good fortune to see Mr. Aitken repeat during the Congress of the British Institute of Public Health in Edinburgh in July, 1893. Two large glass receivers, A and B, are connected with a small boiler by means of pipes. The receiver A is filled with ordinary air—the air of the room. The receiver B is also filled with the air of the room, but before entering the receiver the air is passed through a filter of cotton-wool, and *all dust is removed from it*. The receivers being so prepared, steam is allowed to pass from the boiler into both receivers. As it enters A it is seen to rise in the globe, forming a beautiful white foggy cloud of condensed vapour—a cloud so dense that the observer cannot see through it. On the other hand, when the steam is allowed to enter B, *not*

*the slightest appearance of cloudiness is observed* in this receiver, although it is as full of water as the receiver A, which remains for some time densely packed with fog. The air is "super-saturated" in both receivers, but only in A does the water condense out and form a cloud; in B it remains in its invisible but supersaturated vaporous form. The only possible explanation is that the great difference between the appearance of the two receivers is *due to the dust in the air*. Dusty air—that is, ordinary air—gives a dense white cloud of condensed vapour. Dustless air gives no fogging whatever.

The truth is, that molecules of vapour do not unite with each other and form a particle of fog or mist; but a "free surface" must be present for them to condense upon. The vapour condenses on the dust suspended in the air, because the dust particles form "free surfaces," at which the condensation can take place at a higher temperature than where they are not present. Where there is abundance of dust there is abundance of "free surfaces," and the visible condensed vapour forms a dense cloud; but where no dust particles are present there are no "free surfaces," and the vapour is not condensed into its visible form, but remains in a supersaturated vaporous state until the circulation of the air in the receiver brings it into contact with the "free surfaces" of the sides of the receiver, where it condenses into droplets of water. If the fog in receiver A is allowed to settle, and more steam is blown in, without allowing any dusty air to enter, a fresh fog is formed, and so on many times in succession. It will, however, be noticed that after each condensation the fog becomes less and less dense, but at the same time more coarse-grained and heavier, until at last no visible fog forms, but the condensed vapour will be seen falling as fine rain. Exactly the same thing may be observed if the experiment is varied by cooling "saturated" air by expansion in a large globular glass flask connected with an air-pump.

These experiments show clearly—

1. That when water vapour condenses in the atmosphere, it always does so on some solid nucleus.
2. That the dust particles in the air form the nuclei on which it condenses.



3. That if there were no dust in the air, there would be no fogs, no clouds, no mists, and probably no rain.

That the air, when no dust is present, is really supersaturated in these experiments is evident from the fact that when the dust particles become few, the fog particles are not only few, but are much heavier than when they are numerous; and also from the fact that they increase in size as they fall through the air. Each falling particle becomes a "free surface," at which the supersaturated vapour can condense and increase the size of the drop.

Mr. Aitken draws a graphic picture of what would occur in Nature if there were no dust in the atmosphere. "When the air got into the condition in which rain falls—that is, burdened with supersaturated vapour—it would convert everything on the surface of the earth into a condenser, on which it would deposit itself. Every blade of grass and every branch of tree would drip with moisture deposited by the passing air; our dresses would become wet and dripping, and umbrellas useless; but our miseries would not end here. The insides of our houses would become wet; the walls and every object in the room would run with moisture. We have in this fine dust a most beautiful illustration of how the little things in this world work great effects in virtue of their numbers. The importance of the office and the magnitude of the effects wrought by these less than microscopic dust particles strike one with as great wonder as the great depths and vast areas of rock which, the palæontologist tells us, is composed of the remains of microscopic animals."

Atmospheric dust, capable of fog and cloud production, is probably composed of fine salt-dust from the spray of the ocean, meteoric dust, volcanic dust, condensed gases, and combustion dust. Mr. Aitken admits the accuracy of Professor Tyndall's observation that extreme heat causes dust motes to become invisible in the sunbeam, but he disputes the accuracy of the conclusion that the heat has destroyed the motes. According to him, the heat would seem to destroy the light-reflecting power of the dust by breaking up the larger motes into smaller ones and by carbonising, or in some way changing their colour, and so making them less light-reflecting. But that the motes are

not destroyed is evident, because the fog-producing power of the air so superheated is actually increased—a fact proved by experiment, and explained on the assumption that the number of the particles is increased by being broken up by the heat.

Mr. Aitken bursts into poetry in prose when explaining one source of the immense quantities of fine sodic-chloride dust ever floating in the air, and its usefulness in the economy of Nature. He says: “The ocean, which under a tropical sun quietly yields up its waters to be carried away by the passing air, almost looks as if he repented the gift, when tossed and angry under tempestuous winds, as he sends forth his spray, which, dried and disguised as fine dust, becomes his messenger to cause the waters to cease from their vaporous wanderings, descend in fertilising showers, and again return to their liquid home.”

For testing the amount of dust particles in the air—what Milton calls “The gay motes that people the sunbeams”—Mr. Aitken has designed several ingenious instruments, such as his dust-counter, his pocket dust-counter, and his koniscope. It would be foreign to the subject-matter of these pages to describe these instruments, but it may be useful to explain what is meant by a koniscope (Greek, *κόνις*, *dust*; *σκοπέω*, *I inspect*). In the course of his experiments, Mr. Aitken observed that certain colour phenomena took place in cloudy condensation produced by expansion, and it occurred to him that as the colours so produced varied according to the number of dust particles present in the air experimented on, an instrument might be constructed by means of which, in a rough-and-ready way, no doubt, the amount of dust in the air might be tested by observing the tints produced in it. The instrument consists of an air-pump and a metal tube with glass ends, called the “test-tube.” The capacity of the pump should be from half to three-quarters that of the test-tube. Near one end of the test-tube is a passage by which it communicates with the air-pump, and near the other end is attached a stop-cock for admitting the air to be tested. Pointing the test-tube towards some suitable source of light (preferably daylight), so as to illuminate it from end to end, the stop-cock is closed, and one full stroke of the pump is made, when the resultant colour in the test-tube is at once noted.

This colour would indicate the number of particles. For instance, if there are few particles, one stroke will make the light in the test-tube first blue, then green, then yellow; and then a second stroke, blue and green, finishing with yellow. But if there are a great many particles present, one stroke will not give the whole of the first series of colours, but may stop at the blue.

The number of dust particles in the atmosphere is immense. To take a single instance: Mr. Aitken states that he has found that a cigarette smoker sends 4,000,000,000 particles, more or less, into the air with every puff he makes! He has numbered the dust particles in the atmosphere at many places in Great Britain and on the Continent, and has come to the following conclusions as to the relation between the amount of dust and meteorological phenomena:<sup>1</sup>

1st. The earth's atmosphere is greatly polluted with dust produced by human agency.

2nd. This dust is carried to considerable elevations by the hot air rising over cities, by the hot and moist air rising from sun-heated areas of the earth's surface, and by winds driving the dusty air up the slopes of hills.

3rd. The transparency of the air depends on the number of dust particles in it, and also on its humidity. The less the dust the more transparent is the air, and the drier the air the more transparent it is. There is no evidence that humidity alone—that is, water in its gaseous condition and apart from dust—has any effect on the transparency.

4th. The dust particles in the atmosphere have vapour condensed on them, though the air itself may not be saturated.

5th. The amount of vapour condensed on the dust in unsaturated air depends on the "relative humidity," and also on the "absolute humidity" of the air. The higher the humidity, and the higher the vapour tension, the greater is the amount of moisture held by the dust particles when the air is not saturated.

6th. Haze is generally produced by dust, and if the air be dry, the vapour has but little effect, and the density of the haze depends chiefly on the number of particles present.

<sup>1</sup> *Proc. Royal Soc. Edin.*, vol. xvii., p. 246. 1890.

7th. None of the tests made of the Mediterranean sea air show it to be very free from dust.

8th. The amount of dust in the atmosphere of pure country districts varies with the velocity and the direction of the wind—fall of wind being accompanied by an increase in dust. Winds blowing from populous districts generally bring dusty air.

9th. The observations are still too few to afford satisfactory evidence of the relation between the amount of dust in the atmosphere and climate.

Fog or mist forms in different ways :

1. On a clear, calm night terrestrial radiation so chills the air near the ground that over a level surface like a plain the aqueous vapour of the atmosphere is, through a height of a few inches or feet, condensed into visible water particles, or mist, which is hence called *radiation fog*. It is best seen on autumn nights over low-lying, flat fields, very locally distributed, and very evanescent should a breeze spring up.

2. In winter, and even in summer or autumn, provided the night is clear, and calm, and cool enough, white fogs form rapidly over rivers and lakes, the temperature of which is several degrees above that of the contiguous air. Under these circumstances, the water surface may be seen to *steam* into the atmosphere. While travelling from Ardrossan to Glasgow between 4 and 4.50 a.m. on July 27, 1893, I had an opportunity of observing very perfect examples of radiation fog, and of the fog formed over running water. The morning was calm and clear, and at Ardrossan, on the sea-coast, the thermometer had fallen to 49° in the screen after a rather warm summer's day.

“ The damp of the river fog  
That rises after the sun goes down.”

Or, as Shakespeare has it in *King Lear*—

“ You fen-suck'd fogs, drawn by the powerful sun.”

Cities built on the banks of large rivers are liable to suffer from fogs of this kind, the visitation being intensified by the presence of undue quantities of carbon in the atmosphere, so that the fog is no longer white and pure, as in the open country,



but assumes the colour of pea-soup, or becomes so dense and murky as to rival the darkness of an overcast sky at midnight—so extraordinary is the light-absorbing power of a city-born, smoke-begrimed fog.

Mr. Aitken asks the pertinent question, Why should the smoke which usually rises and is carried away by the winds fall to the ground when we have fogs? He thinks that the conditions which account for the fog also account for the smoke falling. He says :<sup>1</sup> “ When we have fogs the atmosphere is nearly saturated with vapour, and the smoke particles, being good radiators, are soon cooled, and form nuclei on which the vapour condenses. The smoke particles thus become loaded with moisture, which prevents them rising, and by sinking into our streets add their murky thickness to the foggy air. This seems to explain the well-known sign of falling smoke being an indication of coming rain. That the colour or blackness of what is called a pea-soup fog is due to smoke is, I think, evident from the fact that a town fog enters our houses and carries its murky thickness into our rooms, and will not be induced to make itself invisible, however warmly we treat it. It will on no account dissolve into thin air, however warm our rooms, for the simple reason that heat only dissolves the moisture and leaves the smoke, which constitutes a room fog, to settle slowly, and soil and destroy the furniture. If the fog was pure—that is to say, was a true fog, and nothing but a fog—such as one sees in the country, it would dissolve when heated, as every well-conditioned country fog does—at least, I never remember meeting a fog in a country house.”

Somewhat in the character of an optimist, Mr. Aitken puts in a good word for a smoke fog as a deodoriser (carbon), and a disinfectant and antiseptic (sulphurous acid). To say the least, it is a nauseous remedy, if a remedy it can be regarded.

Town fogs, just like the smoke fogs which penetrate our dwelling-houses, are frequently *dry*. Professor E. Frankland, D.C.L., F.R.S., in some experiments on the influence of coal-smoke on foggy air, found that water, when its surface is covered with a film of coal-tar, evaporates much less readily on that

<sup>1</sup> “ Dust, Fogs, and Clouds,” *Trans. Royal Soc. Edin.*, vol. xxx., part i., p. 353.

account. He suggests that this physical fact affords an explanation of the formation of dry town fogs.<sup>1</sup>

3. In winter, when an anticyclone, with its accompanying cold and frost, disperses and gives place to cyclonic conditions and a warm, moist, Equatorial air-current, a fog forms. This is due to the sudden chill of the warm moist air by its impact against the cold surfaces of the ground, trees, and buildings in the locality.

4. In spring, when in quiet, bright, anticyclonic weather the temperature of the air rises quickly over large islands like Great Britain and Ireland, the adjoining seas, still cold from the preceding winter, condense the vapour of the air into dense fogs. These fogs often envelop our east coasts, where they depress the day temperature perhaps 20°, or even 25°, below that of inland stations. Thus, on April 5, 1893, the thermometer rose to 70° at Cambridge, but did not exceed 46° at Yarmouth, where fog prevailed all day. The same phenomenon on a more extensive scale is observed off the banks of Newfoundland, where a polar current of cold water meets the warm air of the mainland of North America, and dense fogs are the result.

5. Large icebergs are nearly constantly surrounded by fog, which they have generated by chilling the surrounding warm moist atmosphere.

6. Promontories, jutting into the sea, and mountains are very apt to generate fog and mist, when they are said to be "cloud-capped." So the poet Longfellow sings in *Evangeline*:

". . . Aloft on the mountains  
Sea fogs pitched their tents, and mists from the mighty Atlantic."

Warm, moist air is forced upwards along their sides to an elevation where saturation is at last reached owing to the lower temperature, and in this way the mist or cloud is produced. Mountain peaks sometimes seem to "smoke" or "steam," owing to the continuous formation of a column of mist or cloud, which spreads out laterally or horizontally to the leeward of the peak. At times also a cloud or mist seems to be motionless at the top of a mountain, or suspended just above it. In reality, the mass of vapour forming the cloud or mist is moving with the wind,

<sup>1</sup> "On Dry Fogs," *Proc. Royal Soc. Edin.*, 1878.



PLATE II.



THE MATTERHORN : FROM THE RIFFELHAUS.  
(A photograph by Greenwood Pim, M.A., August, 1892.)



but the watery particles of which it is composed do not condense until they reach a certain point where the cold mountain-top reduces temperature below the dew-point, while at the other extremity they evaporate and become invisible. The accompanying plate, which is a photograph of the Matterhorn, taken at Riffel, at an elevation of 8,430 feet above sea-level, by Mr. Greenwood Pim, M.A., shows this smoke or steam cloud very well.

In this connection mention may be made of *haze*, which is often observed in anticyclonic, fine, dry weather, particularly during the prevalence of easterly wind in spring. Haze more or less impedes vision, shutting out from view distant mountain landscapes on shore and at sea, causing the horizon to disappear, and the sea and sky to merge into one grey plane. The atmosphere is dry but dense during the prevalence of haze. It is, no doubt, partly caused by the presence of dust and smoke in excess in the air, and probably also by partial condensation of the aqueous vapour by the cold polar air-current which it so often accompanies. At the same time, it must be acknowledged that haze and intense heat are often observed together. A peculiar obscuration of the atmosphere which sometimes appears in summer is called "dust haze" (in German *Höhenrauch*). It is more common on the Continent than in the British Islands. Its origin is not quite understood, but at times it has been traced to extensive fires on the moors or in the forests of Northern Europe. To its formation dust certainly contributes.

The optical phenomenon known as the "Spectre of the Brocken" (*das Brockengespenst*) is nothing more than the magnified shadow of the observer, or of some other object, thrown by the setting sun upon the mist or thin cloud stratum which so often veils the summit or slopes of the Brocken (*Mons Bructerus*, *Melibocus* of the Romans), the culminating point of the Harz Mountains, in Saxony. The mountain has an elevation of 3,740 feet above sea-level. But the phenomenon may be seen from a much smaller height, as will appear from the following account of the "Spectre of the Brocken," as seen from the Hill of Howth, County Dublin, on September 20, 1907, by Mr. Henry A. Cosgrave, M.A., J.P. The bold foreland of Howth rises to a height of 563 feet above the sea. Mr. Cosgrave wrote to me from Broomfield, Howth,

under date September 21, 1907: "As I know what an interest you take in things meteoric, I proceed to tell you of a phenomenon I saw for the first time yesterday. A friend and I were walking on the east cliff about four in the afternoon, when there was a very dense fog seawards. The lower part of the fog was in shadow of the hill, but on the upper part there was brilliant sunshine. We saw our shadows projected on the fog apparently walking upon the part in shadow, and a crown or halo encircled us. We went on some distance, and again saw the same phenomenon. To-day I mentioned the matter to an old fisherman, but he had never heard of it being seen. He said they called the rainbows in the fog 'fog scoffers,' because they intimated that the fog would pass away. I suppose the appearance was the same as the well-known 'Spectre of the Brocken.' "

On rare occasions a stratum of haze forms at a great height above the earth, while the lower strata of the atmosphere remain perhaps unusually clear. This happened on Sunday, May 22, 1870, over a great part of Ireland. So clear was the lower air that Snowdon was indistinctly seen from the Hill of Howth on the north of Dublin Bay, while a vapour fog or haze, suspended in mid-air, absorbed the blue rays of the solar spectrum, causing the sun to assume a pinkish or carmine tint, and a strange lurid light to spread over the landscape. I described the phenomenon in *Symons's Monthly Meteorological Magazine* for June, 1870 (vol. v., p. 65).

*Measurement of Fog Densities.*—At a meeting of the Royal Meteorological Society held on May 15, 1907, Mr. Joseph W. Lovibond, F.R.Met.Soc., exhibited and described an apparatus which he had designed for measuring fog densities. The method is based on the power of selective absorption resident in suitably coloured glass. When this has been graded into mechanical scales of equivalent colour-value, a beam of white light can be progressively absorbed to extinction, and the luminous value of each successive absorption can be stated in quantitative terms. This analytical power also applies to the colour constituents of the beam.<sup>1</sup>

<sup>1</sup> *Quarterly Journal of the Royal Meteorological Society*, vol. xxxiii., p. 275. No. 144. October, 1907.

## CHAPTER XVII

### THE ATMOSPHERE OF AQUEOUS VAPOUR (*continued*)

#### CLOUDS.

WE pass from fogs to clouds by an easy and rational transition. A cloud is a collection of particles of aqueous vapour condensed into watery particles and floating in the atmosphere at some height above the ground. This height varies from a few hundred feet to several miles, feathery cirri having been observed far above him by Gay-Lussac, in September, 1804, when in a balloon at a height of 23,000 feet, or considerably more than four miles. Tyndall has aptly applied the term "water dust" to the minute particles of water, condensed from aqueous vapour, which go to make up a cloud.

The "cloud line," or that level below which cloud formations seldom or never take place, varies in different parts of the world. In South America, Dr. R. H. Scott says it is about 9,000 feet; in the Tyrol it sinks to about 5,000 feet; and in the British Islands, out of a great number of observed cloud levels, one-third were below 2,500 feet.

Lamarck, in 1801, first classified clouds, but it is to the distinguished climatologist, Mr. Luke Howard, F.R.S., that we are indebted for a classification of cloud forms which is still in use. In his *Essay on the Modifications of Clouds*, first published in 1803, and re-issued as a third edition by Mr. John Churchill, of London, in 1865, Howard recognised three primary types and four compound types. The primary types are: (1) Cirrus, or "mares' tails"; (2) stratus, or "ground fog"; (3) cumulus, or "wool-pack." The secondary or compound types are: (1) Cirro-stratus, or "sheet-cloud"; (2) cirro-cumulus, or

“mackerel sky”; (3) cumulo-stratus, or “shower cloud”; (4) nimbus, or “rain-cloud.” These cloud-forms arrange themselves into two groups, when their height is considered—namely, *upper* and *lower* clouds.

I. *Upper Clouds*.—There is good reason to believe that the clouds belonging to this class—cirrus, cirro-cumulus, and cirro-stratus—are usually composed, not of watery particles, but of ice-crystals. The vast height at which these clouds float would suggest this, but they are also the halo-producing clouds, and the phenomena of halos can be explained only by the refraction of light through ice-crystals. Coronæ are white or coloured circles round the sun or moon, with a radius of from  $6^{\circ}$  to  $15^{\circ}$ . Halos are great circles, with a radius of  $22^{\circ}$  to  $46^{\circ}$  ( $22^{\circ} 30'$  and  $45^{\circ} 0'$ ), in which all the colours of the rainbow may be seen.

1. Cirrus (cir.) (Latin, *cirrus*, a *hair*) is the loftiest of all clouds. It consists of delicate wavy sprays, like a wisp of hair, thread fibres, or feathers, often arranged in parallel lines across the sky, these lines apparently converging towards the horizon and diverging near the zenith owing to perspective. Observations of the cirrus cloud are of the first importance in weather forecasting. There is no doubt that its formation is connected with the overflow, in the upper regions of the atmosphere, of air which has been carried aloft in the front of a cyclonic system which is developing. It generally appears in that quarter of the sky from which the coming disturbance is advancing, but its motion is often quite different from that of the wind or of the lower clouds. Thus the cirrus may be travelling from west, while the lower clouds are coming from south-west or south, and the wind from south or south-east. Most usually detached sprays precede the main body of the cirri, as scouts precede a body of troops in the field or on the march. In consequence of the intimate relation which cirrus bears to atmospheric depressions or cyclonic systems, its appearance in the sky often betokens wind as well as broken, rainy weather. In winter its arrival is one of the earliest signs of a thaw.

2. Cirro-stratus (cir.-s.) is commonly formed from cirrus by increased condensation, which extends to a lower level in the sky. When bad weather is approaching, a uniform sheet of



cirro-stratus overspreads the sky. This "sheet-cloud" has been called *Pallium* (Latin, *a cloak*) by Poëy. In it solar and lunar halos are apt to form, and we speak of a watery sun or moon when it has begun to interfere with the solar or lunar rays. As it sinks to a lower level, it becomes denser, entirely intercepting sunshine or moonlight, and soon rain begins to fall from it, while *scud* drifts rapidly before the wind far beneath it. The word *scud* is applied to fragments of cloud of the stratiform or cumulus type in rapid motion. As regards prognosis of rain, we may say that rain is sure to fall when cir.-s. supervenes on cir.—in other words, when the cloud level is descending through the air. On the other hand, when cir.-s. forms while cumuli are in the sky—in fact, by the ascent of the lower clouds—the weather will probably take up, for this cloud will then interfere with evaporation and sunshine, and so check the formation of cumuli—clouds which are very likely to condense into showers.

3. Cirro-cumulus (cir.-c.) consists of small, well-defined, round, oval, or globular dense, or soft and fleecy masses of cloud at a lower level than cirrus. These white woolly masses resemble a flock of sheep lying down. They have also been compared to the markings on a mackerel, hence the expression "a mackerel sky." Cir.-c. is essentially a fine-weather cloud, and is suspended at a great height in the atmosphere, though not so high as cirrus.

II. *Lower Clouds*.—These are stratus, cumulus, cumulo-stratus, and nimbus, and they are usually composed of watery particles—that is, condensed vapour—except in winter or when they freeze into ice-crystals as they rise into the atmosphere, as those of the cumulus type nearly always do.

1. Under the name of "Stratus" (str.), Howard described the cloudy formation which spreads over low-lying ground at nightfall, and vanishes as temperature rises in the morning. He also called it "ground fog," and defined it as "a widely extended, continuous horizontal sheet increasing from below upwards." Dr. Scott<sup>1</sup> says that "stratus is generally a fine-weather cloud, appearing during the evenings and mornings of the brightest days. At times it overspreads the whole sky in the form of a

<sup>1</sup> *Elementary Meteorology*, p. 127. 1883.

low, gloomy, foggy canopy, the atmosphere being more or less foggy under it. All low detached clouds which look like a piece of lifted fog, and are not in any way consolidated into a definite form, are *stratus*."

2. "Cumulus" (cum.) is essentially an evaporation cloud, appearing in its prime when evaporation is taking place rapidly, and when strong upborne or ascensional currents are carrying the aqueous vapour rapidly above the line of saturation or of the dew-point. The cloud in consequence appears with a sharply-defined horizontal base, while its upper portions form magnificent globular masses, snow-white in bright sunshine, but elsewhere—

"Rolled in masses dark and swelling  
As proud to be the thunder's dwelling."

MOORE: *Lalla Rookh*.

Cumulus is seen as either a land cloud or a sea cloud under absolutely contrasted conditions. As a land cloud, it may best be studied in summer or autumn. A rain-bearing depression, we will suppose, has passed away, and the sky has cleared completely at or after nightfall. Terrestrial radiation has full play during the ensuing night, and towards morning the air is damp and very cold for the time of year. The morning breaks without a cloud, but when the sun's power begins to increase, a few soft scud-cumuli begin to fleck the deep blue sky. These clouds rapidly develop in size and density, and rise to a higher and higher plane, as the line of saturation ascends with the rising temperature near the earth's surface. At last the cumuli become piled up into threatening masses, with snow-white, sharply-defined crests. Their summits now begin to spread out in front into a fan-like, cirriform crest, and simultaneously a heavy shower of rain or hail may be observed falling from the base of the cloud mass. Probably a peal of thunder will be heard re-echoing now and again through these *nimbi*, as they are called. Such a cloud formation as that just described is almost confined to the land. Over the sea the sky will either remain clear or the cumuli will be seen to *waste* quickly. The reason for this is clear. Over the land there is a strong ascending air-current due to the increasing heat; over the sea, on the contrary, the air is descending from above to supply the place of the air which has passed in over the land

as a sea breeze. These summer cumuli are especially apt to gather round chill mountain-tops. In tropical climates their formation at certain seasons leads to a daily afternoon thunder-storm and torrents of rain (see p. 304).

Cumulus is not infrequently a sea cloud in high latitudes in winter and during the prevalence of a polar air-current, when there is no cirriform cloud about. Under such conditions sea cumuli form *by night*. A cold land breeze blows off the coast to supply the place of the warmer air over the sea, which has risen to such a height as to lead to condensation of its aqueous vapour into vast masses of frozen cumulus. On the east coast of Ireland I have often witnessed the development of such night cumuli in winter during the prevalence of a northerly or north-easterly wind. A curious result of their formation is the precipitation at sea and along the coast of heavy showers of cold rain and hail, or sleet and snow, while a few miles inland a clear sky and keen frost may prevail.

Sometimes cumulus assumes a modified shape. Instead of towering aloft into great snowy masses, it almost covers the sky, spreading out into long cylindrical rolls, between which gleams of sunlight are seen here and there. This modification has been called by the authorities of the Meteorological Office, London, *Roll-cumulus*.

Again, but more rarely, the cumulus cloud appears inverted, topsy-turvy, or upside down, its globular or mammillated surface being underneath, while its horizontal layer is uppermost. To this rare appearance (which, however, I have often seen) the name "pocky-cloud" is given in the Orkneys, where it is recognised as a sure sign of storm. A more euphonious name for it is "the festooned cloud." It is caused by a warmer and damper stratum of air above, and a colder and drier stratum below—inversion temperature. A very faithful illustration of this cloud will be found in *Symons's Meteorological Magazine* for June, 1874 (vol. ix., p. 65). It was seen at Elterwater, near Ambleside, by Mr. Edward Tucker, junior.

A very interesting feature about cumuli is the peculiar slopes which they commonly assume. As a rule their upper portions travel more quickly than their bases, of which the motion is

retarded by proximity to the earth. Accordingly, the rounded summit of the cloud is seen in advance of the base—the cloud appears to be rolling over upon itself, and this really does occur. But the globular head or crown of the cloud is not directly in front—it is usually inclined to the right-hand side of the line of advance at an angle of some  $45^\circ$  or so, while the base of the cloud similarly trails behind to the left hand of the line of advance. In fact, the whole cloud seems to slope away from the centre of lowest atmospheric pressure, the situation of which is roughly indicated by that of the “neutral point,” or the point of the compass whence the cloud-slope springs. In anticyclonic systems just the reverse sometimes occurs: the base of the cumulus outstrips its apex and the cloud-slope is towards the left hand of the line of advance in front, and towards the right hand behind. In this case the undercurrent travels more rapidly than the upper current, and the *set* of the air is outward from the area of high pressure, the centre of which lies to the right of the observer, who in every case is supposed to stand with his back to the wind (see p. 4).

3. “Cumulo-stratus” (cum.-s.) was described by Howard as “the ‘cirro-stratus’ blended with the ‘cumulus,’ and either appearing intermixed with the heaps of the latter, or *superadding a widespread structure to its base.*” R. H. Scott explains that this is the *cumulus*, as it were, changing into a *nimbus*, or rain cloud. He adds that it is dark and flat at its base, and is traversed by horizontal lines of dark cloud.

4. “Nimbus” (nim.). This is the “rain cloud,” according to Howard, who defines it as “a cloud, or system of clouds, from which rain is falling. It is a horizontal sheet above which the ‘cirrus’ spreads while the ‘cumulus’ enters it laterally and from beneath.” As so defined, it is really the “shower cloud,” or a mass of cumulus which is being rapidly condensed into rain, hail, or snow. It is a composite cloud, towering from the realms of cumulus into those of cirriform cloud above, and streaked with stratiform cloud beneath, so that Howard called this form of nimbus by the composite name of “cumulo-cirro-stratus.”

But with equal propriety the term nimbus is applied to a diffuse



sheet of cirro-stratus from which rain has begun to fall in front of the centre of an area of low pressure (cyclonic system), or, indeed, to any cloud or system of clouds from which rain is actually falling.

Besides the foregoing classical cloud types, mention should be made of *scud*, a term which is used to indicate loosely-formed, vapoury, detached clouds driving rapidly before the wind, as the poet Longfellow has it—

“ Borne on the scud of the sea.”

In recording observations on clouds, the contractions *Cir.*, *Cir.-c.*, *Cir.-s.*, *Str.*, *Cum.*, *Cum.-s.*, *Nim.*, and *Scud*, should alone be used. The scale for the amount of cloud varies from 0 “blue sky,” or “cloudless,” to 10 “entirely overcast.” The *direction from which* all clouds are coming should be recorded. Very often cloud direction is far from corresponding with wind direction, and this is especially true of upper clouds. The *apparent rate* at which clouds move should also be noticed, as well as the radiant points, in the cases of cirrus in particular.

When thunder threatens, cloud undergoes rapid changes of formation, shape, and density, and nearly always a peculiarly dense cirrus or cirro-stratus is superimposed on massive, lurid cumuli. Whenever it is possible, photographs of thunderclouds and of rare cloud formations in general should be taken.

In a report<sup>1</sup> issued early in 1894 by the Vatican Observatory (*Pubblicazioni della Specola Vaticana*, Fasciculus III.), Signor Mannucci, of Rome, gives a brief account of systems of cloud classification. He practically accepts the classification proposed by Abercromby and Hildebrandsson at the International Conference held in Munich in 1891, and set forth in the Cloud-Atlas of Hildebrandsson, Köppen, and Neumayer. This classification recognises ten different species, arranged in five principal groups. The first group (A) comprises the highest clouds in our atmosphere; the second group (B) includes clouds at a medium height; and the third group (C) low clouds. In the fourth group (D) we have clouds in ascending currents; and, finally, the fifth (E) contains the masses of vapour changing in form. In

<sup>1</sup> See *Nature*, [February 8, 1894, p. 341 *et seq.*

the first four groups the letter (*a*) is used to distinguish the forms of cloud usually accompanied by fine weather, and (*b*) for those characteristic of bad weather. The following is the grouping as given by Signor Mannucci :

GROUP A.

Clouds from medium altitudes up to an average of 9,000 metres (29,528 feet).

1. Cirrus (*a*).
2. Cirro-stratus (*b*).
3. Cirro-cumulus.

GROUP B.

Clouds having altitudes from 3,000 to 6,000 metres (9,843 to 19,686 feet).

4. Alto-cumulus (*a*).
5. Alto-stratus (*b*).

GROUP C.

Clouds the bases of which have altitudes from 1,000 to 2,000 metres (3,281 to 6,562 feet).

6. Strato-cumulus (*a*).
7. Nimbus (*b*).

GROUP D.

Clouds on ascending columns of air, with bases about 1,400 metres high, and summits from 3,000 to 5,000 metres (9,843 to 16,405 feet).

8. Cumulus (*a*).
9. Cumulo-nimbus (*b*).

GROUP E.

Fog-banks up to about 1,500 metres (4,921 feet).

10. Stratus.

The cloud nomenclature adopted by the International Meteorological Committee at Upsala in August, 1894, agrees with the above in all essential particulars.<sup>1</sup>

<sup>1</sup> See *Quarterly Journal of the Royal Meteorological Society*, vol. xxi., p. 16 *et seq.* No. 93. January, 1895.

These various cloud forms are exquisitely and artistically portrayed in the *Atlas International des Nuages*, published by Gauthier-Villars et Fils in Paris in 1896, in accordance with the resolutions of the International Meteorological Committee. The *Atlas* was prepared under the supervision of MM. H. Hildebrandson, A. Riggenbach, and L. Teisserenc de Bort, members of the Cloud Sub-Committee of the International Committee.

*Direction and Velocity of Clouds.*—The direction of motion of clouds is always expressed in terms of the point of the compass from which the clouds are coming. It is best observed by sighting a given cloud against a fixed point, as near the zenith as possible to avoid errors due to perspective. By day the top of a flagstaff, the gable of a house, a tall chimney, or a church-spire may be used as a fixed point. At night, should the cloud canopy be broken, stars near the zenith or the moon, when high in the sky, are suitable fixed points. Experience will enable an observer to record a qualitative estimate of the apparent velocity of clouds by using the adjectives “slow,” “fast,” “moderate,” etc.



FIG. 54.—FINEMAN'S NEPHOSCOPE.

*The Nephoscope.*—This term is applied to an instrument for observing the direction and rate of motion of clouds. There are two main types of such an instrument: (1) the reflecting nephoscope, (2) the direct vision nephoscope.

Fineman's nephoscope (Fig. 54) consists of a disc of black glass mounted on a tripod stand, which allows of accurate levelling. A vertical pointer, which can be raised or lowered by a rack-and-pinion movement, is attached to the circumference of the disc in such a way that it can be rotated about the disc. A scale engraved on the edge of the pointer enables us to read off the height of its

tip above the glass surface. On this surface three concentric circles are marked, the radii of the two outer circles being respectively twice and three times as great as that of the innermost circle.

The method of observing is as follows: The observer stations himself in such a position that the image of the cloud in the glass and the central point of the mirror are seen in the same straight line. He then rotates the pointer and adjusts its length until its tip also is brought into this straight line. This done, he moves his head so as to keep the cloud image and the tip of the pointer in coincidence, and notes the radius along which the image appears to travel. This radius marks the direction of cloud drift. A compass needle mounted below the disc enables the observer to identify this direction, but he must bear in mind that in this country the compass needle points about  $18^\circ$  west of true north.

The angular or, more strictly speaking, the tangential velocity of the cloud may be determined by noting the number of seconds required for the image to travel from the centre of the mirror to the first circle or from one circle to the next. If  $a$  be the radius of the inside circle,  $b$  be the height of the tip of the pointer above the reflecting surface, and  $t$  be the time required for the cloud image to traverse the distance  $a$  (both  $a$  and  $b$  being measured in the same units—*e.g.*, millimetres), the value of the tangential velocity as it would appear to an observer at a point on the surface vertically below the cloud is given by the expression—

$$\text{Tangential velocity} = \frac{a}{bt}.$$

Fig. 54 illustrates an adaptation of Fineman's nephoscope, or "cloud-mirror," which Mr. Casella has introduced. As the mirror must be truly horizontal, the instrument is fitted with a circular spirit-level. The earliest form of this cloud-mirror was arranged by J. T. Goddard, and shown in the Great Exhibition of 1851.

Besson's *Comb Nephoscope* will serve as an example of a direct vision nephoscope. It consists of a brass rod about 9 feet long, bearing at its upper end a cross-piece  $3\frac{1}{2}$  feet long, to which a number of equidistant vertical spikes are attached. The rod is



mounted in a vertical position by means of a number of rings and clamps screwed into a tall post in such a manner that it can rotate freely. Its height should be adjusted so that a fixed mark on the rod is at the level of the observer's eye.

When using the apparatus, the observer stations himself in such a position that the cloud selected for observation is seen in the same straight line as the central spike. He then turns the cross-piece until the cloud appears to travel along the line of spikes, while he himself remains motionless. The cross-piece will then be parallel to the line of motion of the cloud, and the direction in which it points can be read off on a graduated circle which is provided for the purpose. The rod may be turned, while the observer stands at some distance away from it, by means of two cords tied to a second shorter cross-piece attached to its lower extremity.

The tangential velocity may be determined by noting the time taken for the cloud to pass from spike to spike. If  $a$  be the distance between the spikes, and  $b$  the distance from the upper cross-piece to the marked point on the rod which has been adjusted to the level of the observer's eye, and  $t$  the observed time, we have as before—

$$\text{Tangential velocity} = \frac{a}{bt}.$$

Both  $a$  and  $b$  must be measured in the same units. The difference in level between the cross-piece and the observer's eye should be the same in all experiments, and hence the instrument must be set up on a level site. If slow-moving clouds are being watched, the observer will require a fixed support to steady his head if satisfactory results are to be obtained. He will also need smoked-glass spectacles to protect his eyes.

#### METHODS OF STATING THE RESULTS OF NEPHOSCOPE OBSERVATIONS.

In stating the results of nephoscope observations one or other of the following methods is generally followed :

1. All clouds are, somewhat arbitrarily, *assumed* to be at a

level of 1,000 metres, and the linear velocity,  $V$ , is then calculated from the formula—

$$V = \frac{a}{bt} \times 1000.$$

2. The height of the cloud is calculated on the assumption that the linear velocity is 1 metre per second.

If  $H$  be this height, we have—

$$H = \frac{bt}{a} \text{ metres.}$$

The International Meteorological Conference at Munich in 1891 recommended that at several stations in each country comparative observations should be instituted of the amount of cloud for the whole sky with an unobstructed horizon, and of zenithal zones of  $45^\circ$  and  $60^\circ$ .

Professor E. G. Hill's "Report on Cloud Observation and Measurement in the Plains of the North-Western Provinces of India during the Period December, 1898, to March, 1900,"<sup>1</sup> is a work of great scientific merit. It was undertaken by Professor Hill at the invitation of the Meteorological Reporter to the Government of the North-Western Provinces of Oudh.

The measurements were made with a pair of photogrameters of French construction (*échassoux*), the standard pattern recommended for this work by the International Meteorological Commission. The photogrameters are in reality photographic theodolites, and are fully described in Professor Hill's Report. To measure the cloud velocities in the observations, Professor Hill used the apparatus known as Monsieur C. G. Fineman's nephoscope, which is described above at pp. 213 and 214.

In the fifteen months from December, 1898, to March, 1900, about 900 pairs of plates were exposed in the photogrameters, and from these nearly 1,000 calculations of heights of clouds have been made.

The results are of great interest, and form a valuable contribution to the literature of meteorology.

One instance may suffice. On March 1, 1900, cirrus clouds were observed at a height of 95,577 feet above Allahabad (309 feet above sea-level), and were ascertained to be travelling at the stupendous rate of 282.2 miles per hour.

<sup>1</sup> By E. G. Hill, Esq., B.A., Professor of Natural Science, Muir Central College, Allahabad.

On another occasion, November 23, 1899, cirrus was seen to travel at a height of 108,050 feet above Allahabad.<sup>1</sup>

*Zenith Nephoscope.*—In the number of the *Annuaire de la Société Météorologique de France* for February, 1903, M. Louis Besson, of the Montsouris Meteorological Observatory, gives the following description of a new nephoscope designed by him, and intended

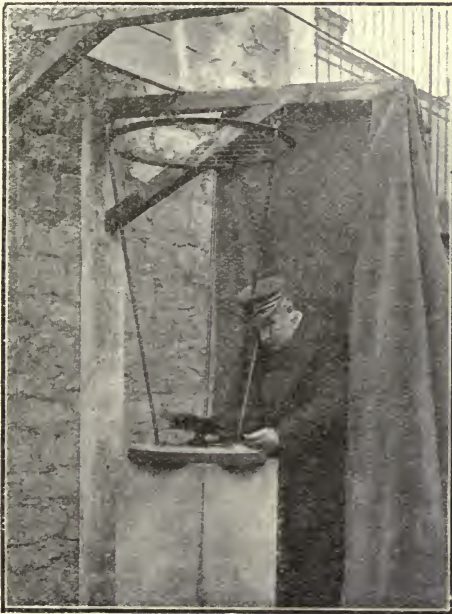

FIG. 55.—BESSON'S ZENITH NEPHOSCOPE.

to take the place of his comb nephoscope (see p. 214), which is not conveniently adapted for zenith observations:

“The apparatus consists essentially in a horizontal frame, on which are stretched two right-angled systems of parallel and equidistant threads forming a square pavement. When the observer places himself underneath such a frame, and looks straight at the

<sup>1</sup> The photogrameters used in this investigation are similar to those which have been described by M. Hildebrandsson in his *Études internationales des Nuages* (Observations et Mésures de la Suède), p. 3 *et seq.*, 1896-97; and by P. José Algué, S.J., in his work, *Las Nubes en el Archipi lago Filipino*, pp. 40, 41.

clouds, he can determine their direction by setting the frame so that one of the systems of threads becomes parallel to it; the other system of threads then appears, as it were, perpendicular to the movement of the clouds, and allows their relative speed to be determined. In reality the observation is not made directly, but by means of a plane mirror placed at an angle underneath the frame. This arrangement has a twofold advantage: first, it frees the observer from an inconvenient posture; in the second place, for a like elevation of the frame, it increases the



FIG. 56.—BESSON'S SPHERICAL MIRROR NEPHOMETER.

effective length of the instrument for the distance which separates the eye from the mirror. The position of the eye is fixed by means of an eyepiece, which may be protected by smoked glass, if this is deemed necessary" (Fig. 55).

*Spherical Mirror Nephometer.*—This instrument (Fig. 56) permits the cloud-percentage (nebulosity) to be measured without any fear of an error in the number of the tenths.

The description of, and the method of using, this new nephometer have been given by the inventor, M. L. Besson, in the



number of the *Annuaire de la Société Météorologique de France* for September, 1906 (p. 241). The following is an abstract: "The convex mirror is a hemisphere of 30 centimetres in diameter. The celestial hemisphere so formed is seen divided into six parts as follows: Two horizontal circles map out a zone of four-tenths on the horizon, another of four-tenths above the first, and a cap of two-tenths round the zenith. Two vertical great circles, perpendicular to each other, divide each of the two annular zones into four parts; finally, the zenith-cap is divided into two equal parts by an arc of a vertical great circle, making with the foregoing an angle of 45 degrees.

"The observer looks along an eyepiece fixed to the pedestal of the mirror. The observer's shadow obstructs only the three squares numbered 8, 9, 10. In order to make an observation, the amount of cloud in each of the seven squares 1 to 7 is noted. Then the instrument is turned through  $180^\circ$ , and in this new position the amount of cloud in the squares, 2, 5, and 7 is noted, these now representing the regions of the sky which correspond to the squares 8, 9, and 10 in the first position."

Both the zenith nephoscope and the mirror nephometer are manufactured by MM. Richard Frères, of Paris. The cost of each is 150 francs (£6).

## CHAPTER XVIII

### THE ATMOSPHERE OF AQUEOUS VAPOUR (*continued*)

#### HYETOMETRY : PRECIPITATION.

IN Chapter XVI. it was shown that precipitation in the form of dew or hoar-frost fell short of an average of 1·5 inches per annum at the Earth's surface (G. Dines).<sup>1</sup> It is manifest that this figure represents a very small proportion of the total precipitation, which takes place in the form of rain, hail, or snow. We shall probably be near the mark when we say that the precipitation in the form of dew or hoar-frost is only about *one-twentieth* of that in the form of rain, hail, and snow. There are districts which are practically rainless; there are other districts where the rainfall is measured in hundreds of inches. On the Khasi Hills, Assam, some two hundred miles to the north-eastward of Calcutta, the average downpour is said to be more than 500 inches, or about 42 feet. Five-sixths of this astonishing rainfall occurs during the south-west monsoon, when the vapour-laden south and south-west winds are forced up by the hills to an altitude far above the saturation line. At Cherrapunji, situated on the southern verge of the Khasi Hills, just outside the Tropic of Cancer (latitude 25° 17' N.), the rainfall in June, 1851, amounted to 148·53 inches, or more than falls in most parts of the British Islands in four years. In 1861 the rainfall is stated to have reached 905·12 inches, of which 336·14 inches are returned for the month of July alone. It is true that these last figures were accepted with reserve by the late Sir John Eliot,<sup>2</sup> and rejected as untrustworthy by Mr. Henry F. Blandford,

<sup>1</sup> See p. 192.

<sup>2</sup> "The Rainfall of Cherrapunji." *Quarterly Journal of the British Meteorological Society*, vol. viii., p. 41. 1882.

F.R.S., F.R.Met.Soc., in a paper on the "Variations of the Rainfall at Cherra Poonjee, in the Khasi Hills, Assam," which he read before the Royal Meteorological Society on April 15, 1891.<sup>1</sup> In discussing this paper, however, Mr. Tripp, F.R.Met.Soc., showed that from a comparison of variations in the rainfall at other stations there was nothing improbable in a maximum of over 990 inches, with a mean of 500, at Cherrapunji.

*The Mean Annual Rainfall of the World.*—The first rainfall map appeared in Dr. Heinrich Berghaus's *Physikalischer Atlas*, published at Gotha in 1845. Professor Loomis, of Yale University, drew the first isohyets for the world in 1882.<sup>2</sup> Isohyets (Greek, *ισός*, equal; and *ἕτερός*, rain) are lines denoting equal depths of rainfall or precipitation, for the term "rainfall" includes all the forms in which water is deposited on the earth's surface—rain, snow, sleet, hail, fog, and dew. Professor Loomis's map was revised in 1887 by Dr. Alexander Buchan, for Sir John Murray's measurements of the world's rainfall,<sup>3</sup> and by Professor Loomis himself in 1889. Two new maps, based on the most recent data, appeared in 1898. One, dealing with the distribution of rainfall over the land, was compiled by Dr. A. J. Herbertson, Ph D.,<sup>4</sup> and was reproduced in Plate XVIII. in the magnificent *Atlas of Meteorology*, which forms the third volume of Dr. J. G. Bartholomew's *Physical Atlas*, published by Archibald Constable and Co., Westminster, in 1899. The other map was drawn by Dr. A. Supan, and published at Gotha in 1898.<sup>5</sup> The dotted lines showing the precipitation over the ocean in Plate XVIII. of the *Atlas of Meteorology* are taken from Dr. Supan's map, and are based on W. S. Black's discussion on rainfall at sea,<sup>6</sup> supplemented by observations taken on the *Novara*, *Gazelle*, and *Elisabeth*. The most striking feature is the great area of excessive rain (over 2,000 millimetres, or 80 inches, per annum) over the Atlantic between

<sup>1</sup> *Quarterly Journal of the Royal Meteorological Society*, vol. xvii., No. 79, p. 146. July, 1891.

<sup>2</sup> *American Journal of Science*, xxiii. and xxv. New Haven, Conn. 1882-83.

<sup>3</sup> *Scottish Geographical Magazine*, iii. Edinburgh, 1887.

<sup>4</sup> *Royal Geographical Society's Extra Publications*. London, 1899.

<sup>5</sup> "Die Verteilung des Niederschlags auf der festen Erdoberfläche," *Petermanns Mitteilungen, Ergänzungsheft*, No. 124. Gotha, 1898.

<sup>6</sup> *Journal of the Manchester Geographical Society*, vol. xiv., pp. 36-56. Manchester, 1898.

Newfoundland and Ireland, and the western extension of the Sahara conditions (rainfall under 250 millimetres, or 10 inches) to  $65^{\circ}$  W. This parched area practically does not occur in the South Indian Ocean, and is found in the South Atlantic only as a very narrow tongue running north-west from the Kalahari desert, in the region where the south-east trade winds blow most regularly. In the Indian Ocean, the region between  $15^{\circ}$  and  $20^{\circ}$  S. has more than 2,000 millimetres (80 inches) of rain !

Dr. Herbertson summarises the facts as to land rainfall as follows :

“ The Equatorial regions are wet, and in most places more than 1,000 millimetres (40 inches) fall every year. The eastern coasts of both the Old and New World receive a relatively heavy rainfall, especially where they are mountainous ; and this is also true for Africa south of the Equator, when we take Madagascar into account. This rain is heaviest in the belt where the trade or monsoon winds strike the land. Between  $20^{\circ}$  and  $35^{\circ}$  from the Equator the rainfall rapidly diminishes, and dry deserts are found west of the region influenced by the trade and monsoon winds.

“ On the polar side of  $35^{\circ}$  the stormy westerly winds bring rain to the western coasts, which are wetter than the eastern ones, although the latter are also affected by the moving low-pressure areas, which have winds blowing from over the sea in front of their centres. The configuration of the land determines the extent of the influence of these stormy winds. In North and South America, in Scandinavia and Scotland, and in New Zealand the moist west winds strike against great mountains, which deflect the air upwards, cool and condense the water vapour, and yield heavy rains. Beyond the crest of the mountains comparatively little rain falls, except in the summer months. These summer rains reach far inland in the regions on the polar sides of  $45^{\circ}$ . Mountains, wherever they exist, are regions of greater rainfall, as they locally cause ascending currents, and deflect horizontal ones upwards.

“ The coldness of lands within the polar circles prevents heavy rainfall, as comparatively little water can exist in the air as vapour.

“ There is, on the whole, a steady diminution of rainfall, from



Equator to Pole, corresponding to the diminution of temperature and of vapour-carrying capacity of the air. Three exceptions should be noted. (1) The coastal lands, where sudden changes of temperature are frequent, and the air is nearly saturated with moisture, are rainy, except where cold currents well up and make a cool area near the coast, as happens near the tropics on the west of the continents. (2) Great temperature changes also occur in mountain lands, and where the air is sufficiently damp, rain is common. (3) The hearts of the continents, far from the source of water vapour in the oceans, and the regions reached by winds blowing out from them over dry land, are very dry."

Dr. Herbertson says that, "comparing the continental and ocean rainfall, it is seen that the latter is greater than the former in high latitudes, but lower in the trade-wind regions outside the Equatorial rain-belt." He further shows, when discussing the mean monthly distribution of rainfall over the land of the globe, that the rainfall zones move north and south with the sun, and attain their maximal northern and southern positions respectively about a month later than it does.

*Rainfall Observations.*—In a letter to Galileo, dated June 10, 1639, B. Castelli, of Perugia, records the earliest authentic measurement of rainfall; but it was an isolated observation, suggested by an exceptionally heavy downpour of rain, and led to no practical advance.<sup>1</sup> In a "Contribution to the History of Rain Gauges," read before the Royal Meteorological Society on March 18, 1891,<sup>2</sup> Mr. G. J. Symons, F.R.S., tells us that, most curiously, the first rain-gauge designed was not an ordinary one, but a recording gauge. On January 22, 1662, Dr. (afterwards Sir Christopher) Wren showed before the Royal Society his experiment of filling a vessel with water, which emptied itself when filled to a certain height. Ten years later a tipping-bucket rain-gauge, on Sir Christopher Wren's plan, was ordered for construction by the Royal Society.

The earliest published returns of rainfall were made in Paris,

<sup>1</sup> Dr. G. Hellmann, "Die Anfänge der meteorologischen Beobachtungen und Instrumente." *Himmel und Erde*, II. Jahrgang, 3 und 4 Hefte.

<sup>2</sup> *Quarterly Journal of the Royal Meteorological Society*, vol. xvii., No. 79.

in 1668, by M. Pierre Perrault, who wrote an anonymous work, *De l'Origine des Fontaines*, and in England by Mr. R. Townley, of Townley, near Burnley, Lancashire, whose observations were begun on January 1, 1677. Three years earlier, in 1674, an unknown observer at Dijon was recording the rainfall, and he afterwards supplied Mariotte, of Paris, with records from that city. The gauge used at Dijon is thus described by Mariotte: "Un vaisseau quarré qui avoit environ deux pieds de diamètre, au fond duquel il y avoit un tuyau qui portoit l'eau de la pluie qui y tomboit dans un vaisseau cylindrique."

In 1695 Mr. Robert Hooke weighed the rainfall at Gresham College, London. The rain-gauge (Fig. 57) used by him consisted of a large bottle called a "bolt head," capable of holding more than 2 gallons, and with a neck 20 inches long. Into it was conducted the pipe of a funnel (apparently of glass like the bottle) 11·4 inches in diameter. The funnel was steadied by two stays or pack-threads strained by two pins. The glasses—that is, the funnel and the bottle—were supported in a wooden frame. The collected water was weighed every Monday morning by troy weight. Thus, from August 12, 1695, to the same date in 1696, 131 pounds 7 ounces 113 grains of rain fell—that is, 29·11 inches.

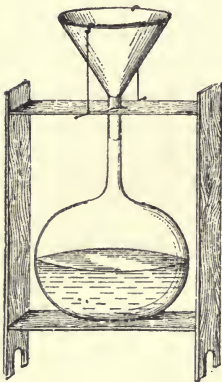

FIG. 57.—HOOKE'S RAIN-GAUGE.

The Twelfth Annual Exhibition of Instruments held by the Royal Meteorological Society, March 3 to 19, 1891, was devoted to rain-gauges, evaporation-gauges, and like instruments. An official description of the various instruments exhibited will be found in the number of the *Quarterly Journal of the Royal Meteorological Society* for July, 1891 (vol xvi., No. 79, p. 180). A few of the many instruments only will need description. The largest gauge ever made has been in use at Rothamsted, Harpenden, Herts, since the beginning of 1853. Its receiving area equals  $\frac{1}{1000}$ th of an acre. A coloured drawing of this monster gauge by Lady Lawes, of Rothamsted, was exhibited; so also was a

specimen of Colonel Ward's 2-inch gauge, one of the smallest in use. One was more than two thousand times as large as the other, and yet their indications did not differ by anything like 5 per cent. The smallest gauge ever used is only 1 inch in diameter, and its readings have been proved by experiments—undertaken by Colonel Ward, and continued by the Rev. C. H. Griffith, and the Rev. Fenwick W. Stow—to differ from those of a gauge five hundred times its size by less than 2 per cent.

Theoretically, square gauges are simpler than circular gauges, but in practice the latter are mostly used, because they are not so apt to get out of shape as the former, and the least denting of the rim of a rain-gauge would interfere with its measurement.

The International Meteorological Congress at Vienna in 1873 suggested for all rain-gauges a circular receiver  $\frac{1}{10}$  square metre in area (about 14 inches in diameter), and considered that the rim should be formed of a strong turned ring of brass, with bevelled edge. But at the Rome Congress, in 1879, it was agreed that, for stations of the second and third



FIG. 58.—METEOROLOGICAL OFFICE RAIN-GAUGE.

order, rain-gauges 8 or even 4 inches diameter are sufficient.

1. *Meteorological Office Gauge*.—This gauge, 8 inches in diameter, is in very general use (Fig. 58). It is made of copper, weighs between  $8\frac{1}{2}$  and 9 pounds, or, with a splayed base, from  $10\frac{1}{2}$  to  $10\frac{3}{4}$  pounds, and has a circular collecting funnel surmounted by a vertical rim,  $5\frac{1}{2}$  inches in depth, in order to catch snow. On top of this rim or cylinder is a stout brass ring about 1 inch in width, ground to a knife-edge above, so that its circular shape is preserved, and the in-splashing of raindrops is entirely pre-

vented. The rain, caught in the funnel, flows through a pipe into a large copper can capable of holding  $4\frac{1}{2}$  inches of rain. From this it is poured into a graduated measure-glass, and its quantity is read off in thousandths, hundredths, and tenths of an inch. A fall of an inch of rain means that a square tray 12 inches long and 12 inches wide would be filled up to a height of 1 inch by such a rainfall.

2. The *Snowdon Gauge* (Fig. 59) resembles the foregoing, but has a diameter of only 5 inches. In it—as in the Meteorological

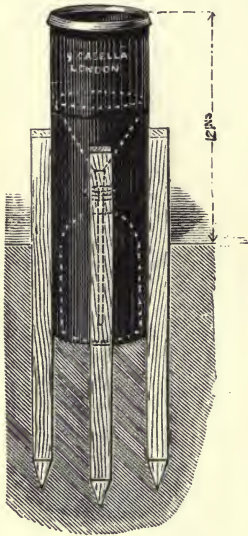

FIG. 59.—SNOWDON RAIN-GAUGE.

Office gauge—a cylinder rises 4 inches vertically from the edge of the cone of the funnel, constituting what is called a “Snowdon rim.” A gauge of this kind in copper is nearly indestructible and independent of frost. The galvanised iron Snowdon gauge is much cheaper, and will last for fifteen or twenty years.

3. The *Mountain Gauge* (Fig. 60) is intended for rough mountain work, and for waterworks purposes in wet districts. It is a float gauge, capable of holding 48 inches of rain. It is superseded by—

4. *The Bradford Gauge* (Fig. 61).—This is a modified Snowdon gauge. The funnel is identical in dimensions with that of the Snowdon gauge, the tube being long enough to reach within an inch of the bottom of the inner can. According to the nature of the site for which this

gauge is intended, the inner can may be made deep enough to contain from 12 to 30 inches of rain, but a total depth of 2 feet is usually sufficient. The bottle is dispensed with.

To check evaporation, a slightly concave sheet of metal should be soldered  $1\frac{1}{2}$  inches below the mouth of the inner can, with a hole  $\frac{3}{4}$  inches in diameter in the centre, and a crescent-shaped opening at one side to facilitate pouring out the contents. To check the measurement, a graduated dip-rod of cedar,  $\frac{1}{2}$  inch wide and  $\frac{1}{4}$  inch thick, tipped with brass, is dropped vertically



into the inner can after the funnel has been removed. The rod, when withdrawn, shows the approximate amount of rain by the dark colour of the portion which was immersed, and the rain is

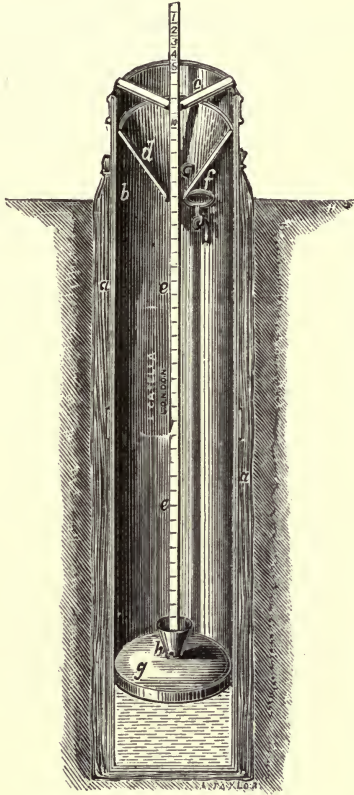

FIG. 60.—MOUNTAIN RAIN-GAUGE.

then measured accurately by means of the measuring-glass, both readings being recorded.

5. *Symons's Storm Rain-Gauge* is not intended for general use, or for yielding continuous records, but for enabling observers to record in detail the rate at which heavy rains fall during thunderstorms. With one of these instruments, in London, on

June 23, 1878, rain was ascertained to be falling for thirty seconds at the rate of 12 inches an hour, or 288 inches a day. The first pattern of this gauge was apt to be broken by frost, and

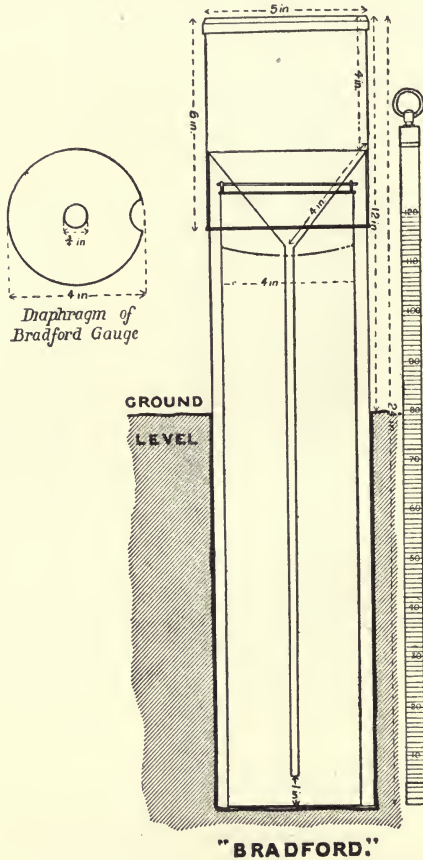

FIG. 61.—BRADFORD RAIN-GAUGE.

therefore could be put out only in summer time. In a second stronger and more elaborate instrument (Fig. 61) the rain passes into a copper cylinder in which is a float, which rises as the rain falls. The float has a string passing round a pulley, and

kept taut by a counterpoise. Therefore, when the float rises, the pulley turns. To the extremity of the axle of the pulley a hand or index is attached, which completes a revolution on a graduated dial when an inch of rain has fallen. Inside the case there is a simple wheel-work whereby another short hand, like the hour-hand of a clock, completes a revolution for 5 inches of rain. With this gauge it is therefore quite easy to read from a window the fall of rain to hundredths of an inch, and by doing this—say, every thirty seconds—the minutest detail of the fall of rain can be ascertained. This instrument is constructed by Negretti and Zambra.

There are several self-registering and recording rain gauges. For example :

6. *Crosley's registering rain-gauge*, of which the area is 100 inches (Fig. 62). Beneath the tube leading from the funnel there is a vibrating divided bucket. When one compartment of this bucket has received a cubic inch of water—that is, when  $\cdot 01$  inch of rain has fallen—the bucket tips, the index advances on the first dial, and the second bucket begins to fill, and so on indefinitely.

Crosley was a gas-meter maker, and brought out his gauge first in the year 1829.

7. Messrs. Yeates and Son, of Dublin, have designed a very ingenious modification of Crosley's instrument, by which it is made to record the rainfall electrically. In their *electrical self-registering rain-gauge* (Fig. 63, p. 230) the funnel is 100 square inches in area, and the measuring bucket (the working parts of which are made of platinum alloy, with agate bearings) is adjusted to turn with 1 cubic inch of water. At each turn of the bucket electrical contact is made, which is recorded on a chart. The recording apparatus can be placed in any convenient position indoors. Each

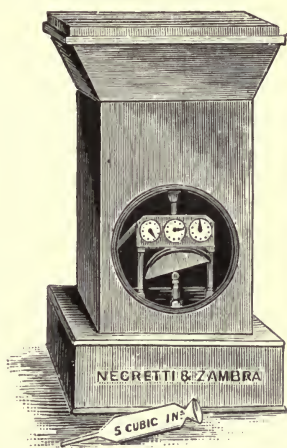

FIG. 62.—CROSLY'S SELF-REGISTERING RAIN-GAUGE.

chart records for one week in a manner similar to the ordinary barograph, and so possesses the advantage of reference at any time. As this apparatus is entirely self-recording, each cubic inch of water, as it is weighed and recorded, is emptied out, so that no error can arise from evaporation.

8. *Casella's Recording Rain-Gauge* (Fig. 64).—In this pattern the rainfall is measured by means of a new form of tilting bucket, in which provision is made that the water dropping in during the actual tilting of the bucket shall be conveyed to the right compartment of the bucket—*i.e.*, to the compartment just coming into position to receive the water.

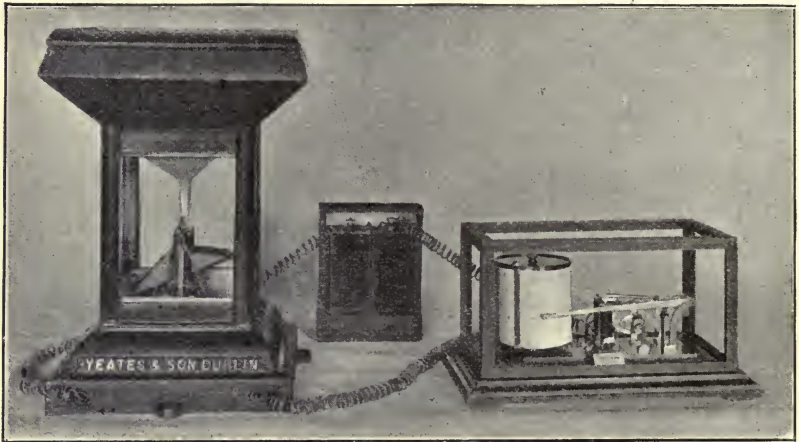

FIG. 63.—YEATES'S ELECTRICAL SELF-REGISTERING RAIN-GAUGE.

The recording mechanism consists of an electro-magnet, the armature of which is connected to a cam, by means of which the pen is raised on the revolving drum. This cam is counter-poised so that the force required to lift the pen is the same in all positions.

The chief advantages of this pattern are as follows :

(1) Rubbing platinum contacts are made use of, which are much more reliable than mercury contacts.

(2) The instrument is not liable to stick when the pen is near the top of the drum.



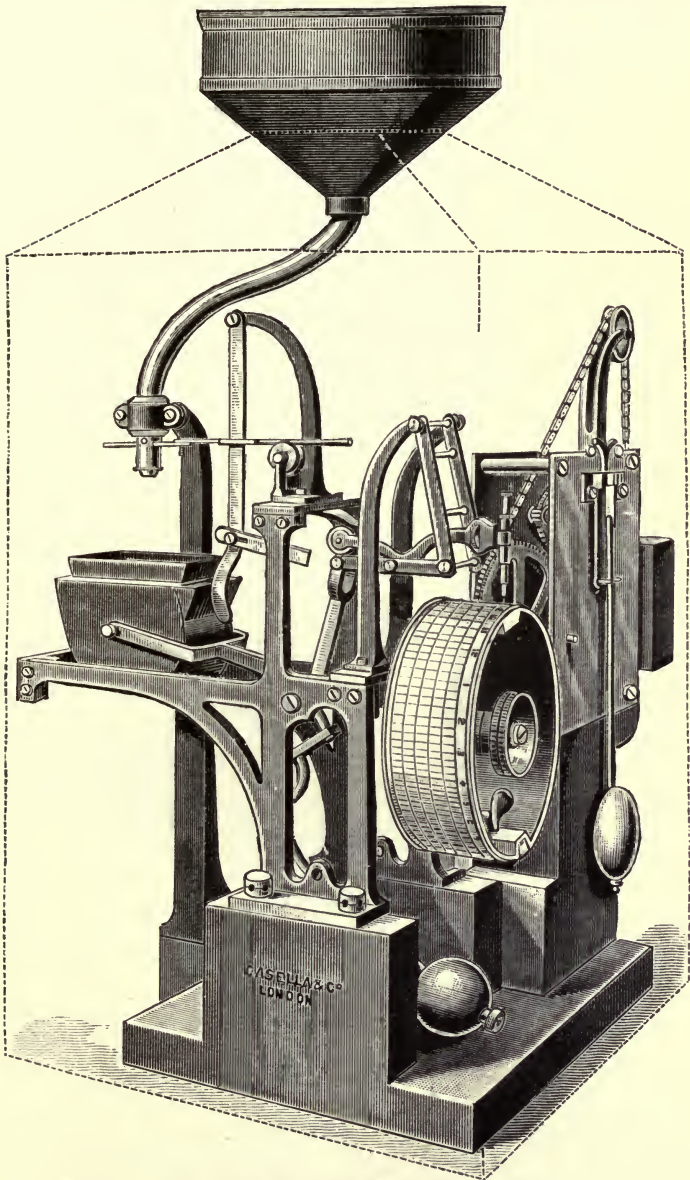

FIG 64 —CASELLA'S RECORDING RAIN-GAUGE.

(3) Every 0.01 of an inch is recorded.

The collecting arrangements are enclosed in a copper or

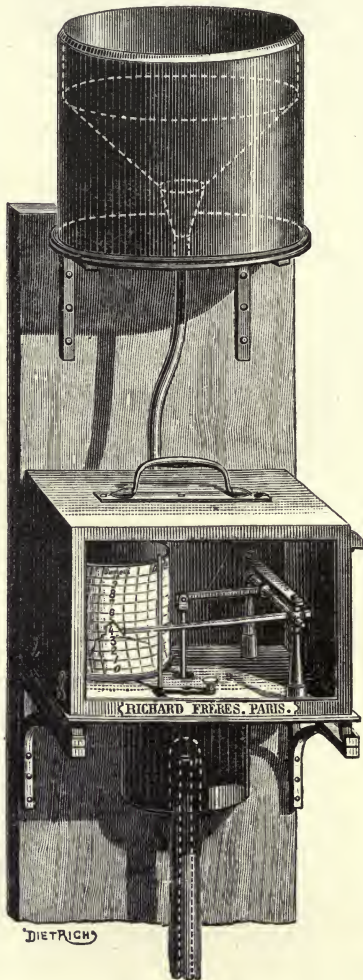

FIG. 65.—RICHARD'S SELF-RECORDING RAIN-GAUGE (FLOAT PATTERN).

galvanised iron case, with an 8-inch funnel, and the recording mechanism, which is kept indoors, is usually placed in a polished mahogany case, with glass windows.

9. MM. Richard Frères, of Paris, have invented a float pattern and a balance pattern *self-recording rain-gauge*. In the float pattern (Fig. 65) a funnel collects the rain, which is carried by a pipe into a reservoir in which there is a float. A style, carrying a writing pen, follows the motion of the float, rising 4 inches

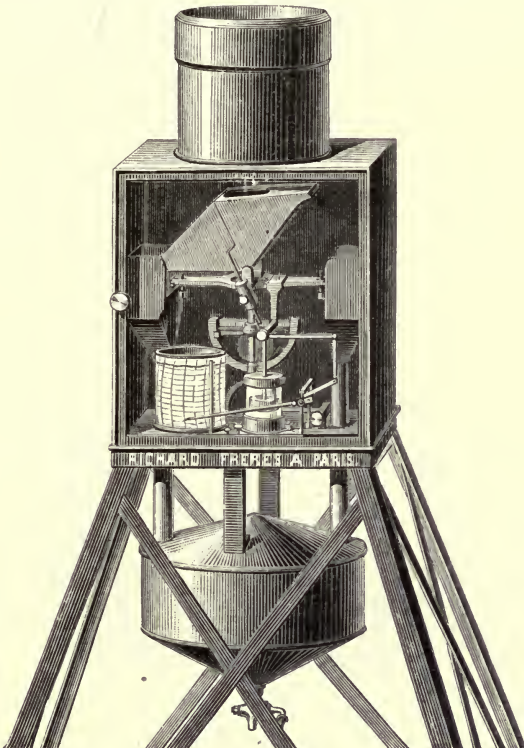

FIG. 66.—RICHARD'S SELF-RECORDING RAIN-GAUGE (BALANCE PATTERN)

for a rainfall of  $\frac{1}{4}$  inch. When the pen reaches the top of a revolving drum, the reservoir empties itself automatically by means of a siphon, the float falls to the bottom, and the pen returns to zero. The siphon is started by an electro-magnet, which, on the circuit of a battery being completed, pulls the float down and causes a sudden rise of the water-level, thereby filling the siphon. In the balance or bucket pattern (Fig. 66) the rain

is led into a tipping bucket divided into two compartments and placed on a balance. One of these compartments being under the funnel, the rain falls into it and causes the balance to descend. A writing pen records this motion on a revolving drum. When the pen has reached the top of the drum ( $\cdot 4$  inch of rain), the tipping-bucket reservoir oscillates, and the water filling the first compartment is emptied into a controlling reservoir. This motion causes the second or empty compartment of the bucket

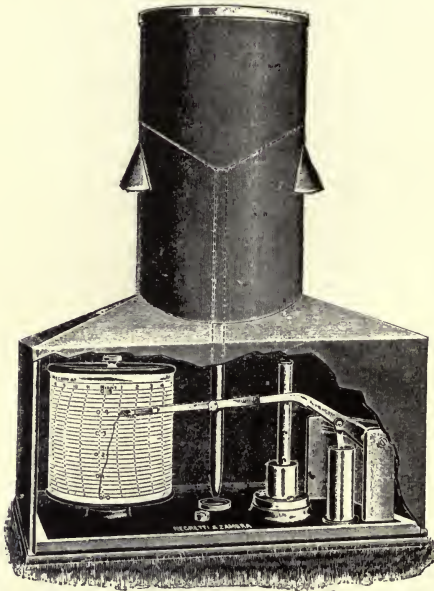

FIG. 67.—NEGRETTI AND ZAMBRA'S HYETOGRAPH (UPPER PART).

to place itself under the funnel. The filling and emptying of each compartment are alternately and automatically produced, and to each of these double operations a rise and a fall of the writing pen corresponds.

*Negretti and Zambra's Hyetograph.*—For obtaining satisfactory records of the duration and intensity of rainfall it is imperative that the rain-scale on the chart should be an open one. This desideratum may be achieved in various ways, the most obvious



of which would appear to be the use of a very high drum (which is a costly matter), or by automatically emptying the collected water at convenient intervals. This latter is usually achieved by the water in the float cylinder being made to siphon away as in the well-known Halliwell's Patent Rain-Gauge, of which

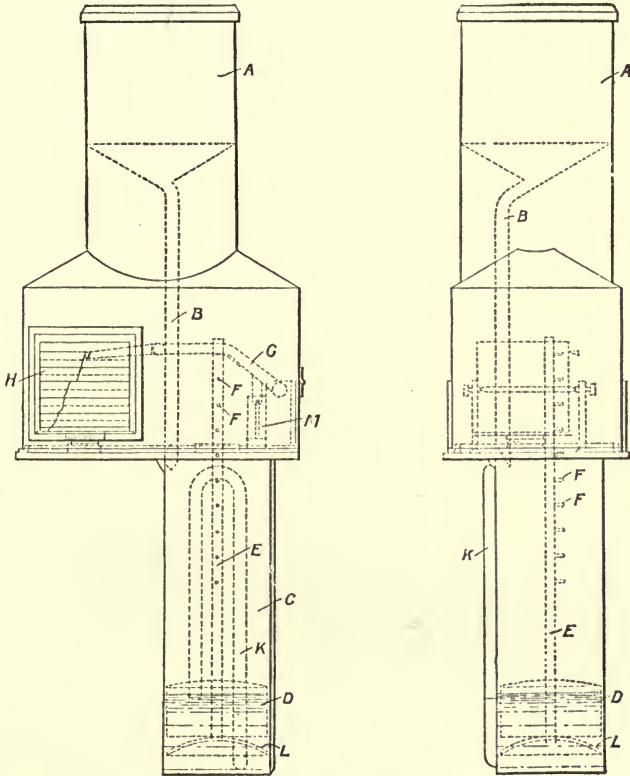

FIGS. 68 AND 69.—NEGRETTI AND ZAMBRA'S HYETOGRAPH.

Messrs. Negretti and Zambra are the makers. An automatic mechanical siphon which can be trusted not to get out of order involves an expense in construction which could not be incurred in a gauge of low price, and for this reason a mechanical device affecting the pen only is substituted in the new instrument styled

the hyetograph, patented in 1908, and marking a new departure in self-recording rain-gauges (Fig. 67). This device enables an open scale of  $\frac{1}{2}$  inch of rainfall to be recorded on a chart measuring about 3 inches in height.

The hyetograph, as will be seen from the plan (Figs. 68 and 69), is built on a cast-iron plate well protected from rust by a special galvanising process. On the plate and underneath is bolted the copper float chamber C, with its accompanying siphon-tube K.

As long as rain continues to fall, the copper float D rises, moving in a guide, up to the maximum capacity of  $4\frac{1}{4}$  inches. On a spindle E, rising from the float D, are a number of projecting pins FF which engage successively with a projection on the lever G, which lever is so pivoted that when the pen reaches the top of the chart, the lever disengages with the pin, and falls by its own weight on to the next lower pin, which is so placed to allow the pen to fall to zero on the chart. The float therefore continually ascends during rainfall, but at each successive  $\frac{1}{2}$  inch of rain the pen descends to zero, and recommences its upward movement.

As no automatic siphon is used, it is obvious that the rain will collect in the float chamber until it is removed, and the float cylinder is constructed of sufficient size to allow an accumulation of over 4 inches of rainfall, which is the maximum likely to occur in one day in any locality in Great Britain and Ireland (except the wettest parts of the Lake District and on high mountains).

In order to remove the water the hyetograph is constructed with a specially designed hand-started siphon K, which is actuated when desired, and empties the float chamber of any water which may have accumulated.

The chart is wound round a clockwork cylinder H, making one revolution in twenty-four hours ; the effective length being 10.8 inches, giving 0.45 inch for an hour.

The whole of the working parts are protected by a stout galvanised iron cover A, hinged at the side, having an observation window, and surmounted by a stout brass rim of 6-inch diameter.

From the above description it will be seen that the hyetograph has very few parts, is extremely simple to erect, and offers practically no opportunities of going out of order. The moving parts

are three only in number, viz., the clock-drum, the float, and the pen lever.

The hyetograph is constructed especially to conform to the standard instructions for fixing rain-gauges—viz., that the funnel should be between 12 and 18 inches above the ground.

It can be fixed with the base plate on the ground and the float chamber underneath; in any way, provided a space is allowed for the water to pass rapidly away after siphoning.

The clock makes one revolution in 24 hours, but need only be wound up once a week. The small dash pot M under the pen lever is filled with the oil supplied, until the piston is just covered when in its highest working position.

If it is desired to empty the hyetograph when less than  $\frac{1}{2}$  inch of rain has accumulated, about a pint of water may be poured into the float-vessel through the aperture in the cast-iron plate, the siphon being then discharged.

It is necessary (say once a week, when winding the clock) to lift the float spindle E to its highest limit in order to clear away any soot or grit deposited from the rain water in the cylinder C. Also at least once a month the whole length of the spindle E and pins FF should be carefully wiped with a clean rag just moistened with good sewing-machine oil.

The case is designed to allow of the circulation of a current of warm air to assist in melting snow as it falls into the funnel.

A night-light or small spirit-lamp will give the necessary heat.

The hyetograph, complete with 100 special charts, costs £6 15s. Extra charts, per 100, cost 7s. 6d.

On May 15, 1907, Dr. Hugh Robert Mill, President of the Royal Meteorological Society, read a paper on "The Best Form of Rain-Gauge."<sup>1</sup> In his opinion the three best patterns are: (1) The Snowdon Rain-Gauge, which he has adopted as the standard for the British Rainfall Organisation, of which he is the very able Director; (2) the Bradford Rain-Gauge, designed by Sir Alexander Binnie, which is simply a Snowdon gauge of great capacity, made of proportionately stout material very strongly put together, and suitable for monthly readings in wet

<sup>1</sup> *Quarterly Journal of the Royal Meteorological Society*, vol. xxxiii., No. 144, p. 265. October, 1907.

localities, such as mountains or moorlands ; and (3) the Meteorological Office 8-inch Rain-Gauge.

No matter what rain-gauge is employed, the instrument should be firmly set in a well-exposed position, at least as far in feet from any building, tree, or high wall as the height of that obstacle. "The angle subtended in each azimuth by the nearest obstacle, such as a building or tree, should not exceed  $30^\circ$ , and the true bearing of the obstacle from the gauge should be carefully measured and noted in the register" (R. H. Scott). The Meteorological Office recommends, in plain language, that the distance between the gauge and the nearest object should be at least twice the height of that object. The gauge should be placed on the ground rather than on a roof, unless in the case of a small town garden, in which it is impossible to obtain a sufficient exposure. The height of the rim of the funnel should be 1 foot above the ground. This should be given in all returns of rainfall, as well as the height of the gauge above mean sea-level. It is essential that the top of the cylinder above the funnel should be absolutely horizontal. The gauges used by the Meteorological Office are now made with a splayed base, which can be firmly embedded in the ground. Secured in this way, the gauge cannot be blown over in a gale or displaced when the funnel is removed for measuring the rainfall.

*Measurement of Rain.*—At Normal Climatological Stations the rainfall should be measured at 9 a.m. daily, and the amount should be entered to the *previous day*, for of the twenty-four hours which elapsed since the last measurement, fifteen belonged to the previous day, and only nine to the day on which the measurement is made. The gauge must be examined daily, whether rain has fallen or not, for dew, hoar-frost, or fog may yield an appreciable precipitation. Daily examination also safeguards against errors arising from the accidental or mischievous addition of water. If there is no water in the gauge, a line or dash should be inserted in the register. The water is poured from the can in the interior of the gauge into the graduated measure-glass, which is scaled to represent hundredths and tenths of an inch up to half an inch of rainfall ( $\cdot 50$  inch). If the fall exceeds half an inch, the measurement



must be made in instalments not necessarily of half an inch precisely. For example, we may measure a fall of 1·581 inches thus:  $\cdot490 + \cdot485 + \cdot496 + \cdot110$  inch. In such a case the water first measured should be carefully preserved until the whole rainfall has been registered and the amount written down. It should then be remeasured as a check on the first reading. The measure-glass must be placed on a perfectly level surface before reading, the observer's eye being brought to bear on the surface of the water at a right angle, so as to avoid errors of parallax. Allowance should be made for capillary attraction, by which the water is drawn a little way up the sides of the glass above the general level in the measure. The reading then should be taken at the bottom of the concave meniscus, or curved surface of the water. The reading should be to the nearest hundredth of an inch in all cases, but it may be to three places of decimals, if extreme accuracy is desired. In the former case, falls of less than  $\cdot01$  inch, but more than  $\cdot005$ , inch may be entered as  $\cdot01$  inch. If the amount collected in the gauge is less than one-tenth of an inch, the decimal point and the first 0 should always be entered in the register. Thus, seven-hundredths should be written  $\cdot07$  inch, and, to three places of decimals, seventy-one thousandths,  $\cdot071$  inch. Even the minutest quantity ( $\cdot001$  inch) should be recorded, but a day is not to be counted a "rain day" unless the measurement amounts to  $\cdot005$  inch (five thousandths of an inch). Very heavy falls of rain should, if possible, be measured immediately after they occur, and noticed in the "Remarks" column of the *Meteorological Register*. The amount should, of course, be included in the next regular entry.

In the modern and improved measuring-glass, the lower part is made to taper to a point internally, so as to enable the critical quantity of  $\cdot005$  inch to be very clearly defined. The divisions for each hundredth of an inch should be distinctly etched on the glass, and the capacity up to each mark should be as follows in grains of water at  $60^{\circ}$  F. (see table on p. 240).

More rain is collected on the ground than on the top of a building or of a stand at a height above the ground. In *British Rainfall*, 1880, will be found papers on this subject by the late Mr. George Dines, F.R.Met.Soc., and the late Mr. G. J. Symons,

F.R.S. The latter writer believed that the deficiency in the amount of rain collected in gauges on high buildings is wholly due to the position of the gauge, to the configuration of that portion of the building which is close to the gauge, and to the strength and direction of the wind during times of rain. In the many experiments which Mr. Symons quoted there was no evidence of any difference between the fall of rain, at various heights from 60 feet to 260 feet above the ground. Observations made at the Wolverhampton Waterworks in the years 1849-52 showed that the rainfall on the top of the water-tower, 180 feet high, was on the average only 76 per cent. of that recorded by a low gauge at the foot of the tower on a post about 7 feet high. Season,

TABLE VI.—CAPACITY OF MEASURING-GLASSES FOR RAIN-GAUGES.

	For 5-inch Gauge.		For 8-inch Gauge.	
		Grains.		Grains.
Up to .005 inch	..	25		63
"   .01   "	..	50		127
"   .02   "	..	99		254
"   .03   "	..	149		381
"   .04   "	..	198		508
"   .05   "	..	248		635
"   .10   "	..	496		1,269
"   .20   "	..	992		2,539
"   .30   "	..	1,488		3,808
"   .40   "	..	1,984		5,078
"   .50   "	..	2,480		6,347

however, had a marked influence, for while the ratio for the summer five months, May to September, averaged 81 per cent., that for the winter and windy five months averaged only 68 per cent.

Symons's explanation is now generally accepted, and it has finally disposed of the old theory that the growth of the raindrop by the condensation of particles of aqueous vapour floating in its path through the air was adequate to explain the difference of rainfall with elevation. Sir John Herschel, it is true, had already demolished this theory, by showing that the latent heat of steam being about 1,000° F., drops of rain, if they acquire an increase in weight amounting to 1 per cent. by condensed vapour, must in so doing have their temperature raised 10° F. If they acquire an increase of 5 per cent., they must have their

temperature raised about 50° F. In the paper from which we have culled these remarks, Mr. Symons observed:<sup>1</sup> “Experimental evidence proves that Mr. Jevons was quite right in his theoretical view—that the fall of rain is practically identical at all elevations, and that the observed differences are due to imperfect collection by the gauges.”

*Size of Raindrops.*—When we consider the enormous mass of material which has been accumulated regarding the quantity of rain which falls, it is remarkable how little attention appears

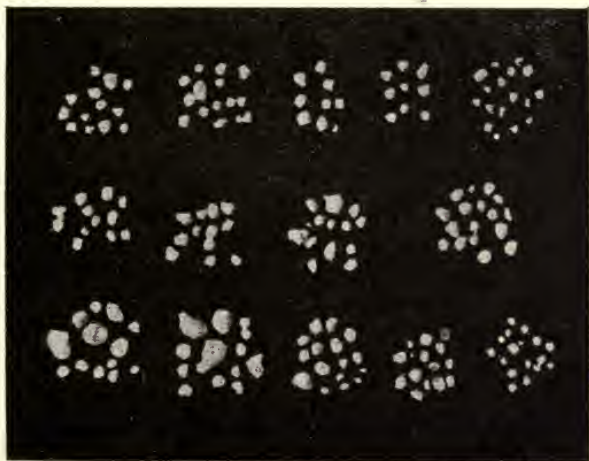

FIG. 70.—FORMS OF RAINDROPS.

Complete set of samples from the great general storm of August 20, 1904. Duration of storm, fifteen hours. One raindrop sample per hour was taken throughout the storm.

(Reproduced by permission of the United States Weather Bureau.)

to have been given to the number and size of the drops. A very simple and ingenious method of studying rain-drops is described in a paper in the *U.S. Monthly Weather Review* for October, 1904, by Mr. Wilson A. Bentley. The raindrops are allowed to fall into a layer of dry flour 1 inch deep, which is exposed to the rain for a few seconds. The flour is allowed to stand for some time, and the pellets of dough, each representing a raindrop, are then picked out and may be preserved. The method was tested by

<sup>1</sup> *British Rainfall*. 1881. P. 45.

allowing measured drops of water to fall from a height into the flour; it was found that the dough pellet differed but little in size from the drop which produced it. In the paper a series of interesting photographs of such dough-pellets is given, illustrating the variation in the size of the raindrops during the course of showers of different types. The largest drops met with somewhat exceeded  $\frac{1}{5}$  inch in diameter. This is in agreement with the observations of Wiesner (quoted by Hann in his *Lehrbuch*), which gave 7 millimetres as an upper limit. Mr. Bentley gives tables showing the relative frequency of occurrence of drops of various sizes in rain from various kinds of clouds.<sup>1</sup>

In reference to the remarkable statements of Sir John Herschel just quoted, the effect of rainfall in warming the air may be imagined from a calculation by the late Rev. Dr. Haughton, F.R.S., Senior Fellow of Trinity College, Dublin,<sup>2</sup> that "1 gallon of rainfall gives out latent heat sufficient to melt 75 pounds of ice, or to melt 45 pounds of cast iron. From this datum it is easy to see that every inch of rainfall is capable of melting a layer of ice upwards of 8 inches in thickness (exactly 8.1698 inches) spread over the ground." From such considerations Dr. Haughton concluded that on the west coast of Ireland the heat derived from the rainfall is equivalent to one-half of that derived from the sun (R. H. Scott).

The *chief physical cause* of rain is the sudden chilling of comparatively warm air, more or less laden with moisture, either by its ascent into the upper and colder regions of the atmosphere, or by its impact against cold mountain slopes or (in winter) the colder surface of the ground, as on the western coasts of Europe. The former cause is more potent in summer, the latter in winter. It was formerly supposed that rain was largely caused by the mixture of masses of air of different temperatures. But, even supposing that any such admixture did take place (which is problematical), Dr. J. Hann, of Vienna, has shown, from a comparison between the units of heat set free by condensation and the weight of aqueous vapour per cubic foot of air at any two given temperatures—one high, the other low—that the mixture of volumes of air cannot be very effective in causing

<sup>1</sup> *Nature*, February 23, 1905.

<sup>2</sup> *Physical Geography*, p. 126.



precipitation ; in fact, the setting free of latent heat in the process of condensation largely prevents that fall of temperature which is assumed to take place and to cause a rainfall.

The electricity of the atmosphere also plays an important part in the production of rain. It may not be generally known that, apart from the sublime and often awe-inspiring electrical phenomena which accompany a thunderstorm, electricity is always at work in the earth's atmosphere. And not the least useful product of that work is the raindrop.

Lucien Poincaré, Inspecteur - Général de l'Instruction Publique, Paris, writes :<sup>1</sup> " If the pressure of a vapour—that of water, for instance—in the atmosphere reaches the value of the maximum pressure corresponding to the temperature of the experiment, the elementary theory teaches us that the slightest decrease in temperature will induce a condensation, that small drops will form, and the mist will turn into rain.

" In reality matters do not occur in so simple a manner. A more or less considerable delay may take place, and the vapour will remain supersaturated. We easily discover that this phenomenon is due to the intervention of capillary action. On a drop of liquid a surface tension takes effect, which gives rise to a pressure which becomes greater the smaller the diameter of the drop.

" Pressure facilitates evaporation, and on more closely examining this reaction we arrive at the conclusion that vapour can never spontaneously condense itself when liquid drops already formed are not present, unless forces of another nature intervene to diminish the effect of the capillary forces. In the most frequent cases these forces come from the dust which is always in suspension in the air, or which exists in any recipient. Grains<sup>2</sup> of dust act by reason of their hygrometrical power, and form germs, round which drops presently form. It is possible to make use, as did M. Coulier as early as 1875, of this phenomenon to carry off the germs of condensation, by producing by expansion in a bottle containing a little water a preliminary mist, which purifies

<sup>1</sup> *La Physique Moderne, son Évolution* (Cf. " The New Physics and its Evolution." The International Scientific Series. Edited by F. Legge. London : Kegan Paul, Trench, Trübner and Co. 1907. Pp. 242-244.)

<sup>2</sup> See p. 195, *supra*.

the air. In subsequent experiments it will be found almost impossible to produce further condensation of vapour.

“But these forces may also be of electrical origin. Von Helmholtz long since showed that electricity exercises an influence on the condensation of the vapour of water, and Mr. C. T. R. Wilson, with this view, has made truly quantitative experiments. It was rapidly discovered after the apparition (*i.e.*, discovery) of the X-rays that *gases* that have become conductors—that is, ionised gases—also facilitate the condensation of supersaturated water vapour.”

Röntgen, in 1895, showed that when a current of electricity was made to pass through a vacuum tube, the tube emitted rays which were capable of passing through bodies opaque to ordinary light. These rays could, for example, pass through the flesh of the body, and throw a shadow of the bones on a suitable screen.

The Röntgen rays, or X rays as they are also called, cause gases, and even liquids and solids, through which they pass to become conductors of electricity. Again, gases exposed to Röntgen rays are found to include particles charged with electricity—some with positive, others with negative electricity. “We know from these investigations,” says Sir Joseph Thomson,<sup>1</sup> “that electricity, like matter, is molecular in structure—that just as a quantity of hydrogen is a collection of an immense number of small particles called molecules, so a charge of electricity is made up of a great number of small charges, each of a perfectly definite and known amount.”

One of the most wonderful and interesting advances ever made in physics was the discovery and investigation of radio-activity—the power possessed by certain metallic substances and their compounds of giving out rays which, like Röntgen rays, affect a photographic plate, make certain minerals phosphoresce, and make gases through which they pass conductors of electricity (Thomson). Examples of such radio-active substances are uranium (Becquerel), thorium (Schmidt), radium and polonium (Monsieur and Madame Curie), actinium (Debierue), and potassium (Campbell). Professors Rutherford, Soddy, and other

<sup>1</sup> “Presidential Address to the British Association for the Advancement of Science,” Winnipeg, Manitoba, August, 1908.

physicists, through their researches, have recently added many new radio-active substances to this classical list.

“The radiation emitted by these substances,” says Sir Joseph Thomson, “is of three types, known as  $\alpha$ ,  $\beta$ , and  $\gamma$  rays. The  $\alpha$  rays have been shown by Rutherford to be positively electrified atoms of helium, moving with speeds which reach up to about one-tenth of the velocity of light. The  $\beta$  rays are negatively electrified corpuscles, moving in some cases with very nearly the velocity of light itself, while the  $\gamma$  rays are unelectrified, and are analogous to the Röntgen rays.”

In his Presidential Address Sir Joseph Thomson also tells us that “a knowledge of the mass and size of the two units of electricity, the positive and the negative, would give us the material for constructing what may be called a molecular theory of electricity, and would be a starting-point for a theory of the structure of matter; for the most natural view to take, as a provisional hypothesis, is that matter is just a collection of positive and negative units of electricity, and that the forces which hold atoms and molecules together, the properties which differentiate one kind of matter from another, all have their origin in the electrical forces exerted by positive and negative units of electricity, grouped together in different ways in the atoms of the different elements.”

On February 1, 1901, Mr. C. T. R. Wilson read a paper before the Royal Society on the “Ionisation of Atmospheric Air.” The principal results of his investigation were (1) that ions are continually being produced in atmospheric air (as is proved also by Geitel’s experiments), and (2) that the number of ions of each kind (positively and negatively charged) produced per second in each cubic centimetre of air amounts to about twenty.<sup>1</sup>

To return to M. Poincaré,<sup>2</sup> “We are thus led by a new road to the belief that electrified centres exist in gases, and that each centre draws to itself the neighbouring molecules of water, as an electrified rod of resin does the light bodies around it. There is produced in this manner round each ion<sup>3</sup> an assemblage of

<sup>1</sup> *Proc. Roy. Soc.*, vol. lxxviii., pp. 151-161. May 4, 1901. <sup>2</sup> *Loc. cit.*

<sup>3</sup> An “ion” is “any minute material particle which carries an electrical charge.” (*Hints to Meteorological Observers.* By W. Marriott, F.R.Met.Soc. Sixth edition. 1906.)

molecules of water, which constitute a germ capable of causing the formation of a drop of water out of the condensation of excess vapour in the ambient air. As might be expected, the drops are electrified, and take to themselves the charge of the centres round which they are formed ; moreover, as many drops are created as there are ions. Thereafter we have only to count these drops to ascertain the number of ions which existed in the gaseous mass.

“To effect this counting, several methods have been used, differing in principle, but leading to similar results. It is possible, as Mr. C. T. R. Wilson and Professor J. J. Thomson have done, to estimate, on the one hand, the weight of the mist which is produced in determined conditions, and, on the other, the average weight of the drops, according to the formula formerly given by Sir G. Stokes, by deducting their diameter from the speed with which this mist falls ; or we can, with Professor Lemme, determine the average radius of the drops by an optical process—viz., by measuring the diameter of the first diffraction ring produced when looking through the mist at a point of light.”

Mr. C. T. R. Wilson has observed that the positive and negative ions do not produce condensation with the same facility. Condensation by negative ions is easier than by the positive. Hence the negative electricity of rain.

In the second edition of Preston's *Theory of Heat* (p. 408), the Editor, Mr. J. Rogerson Cotter, M.A. (Dub.), writes :

“Dust-free air may contain water vapour of a density several times as great as that necessary for saturation. For if a very small drop were to form, it would evaporate unless the vapour pressure were great enough to be in equilibrium with the curved surface. If drops of various sizes were present, the small ones would tend to evaporate and condense on the larger ones.

“C. T. R. Wilson has shown that if air containing water vapour be freed from dust and supersaturated by a sudden expansion, a cloud or fog will form if the air is *ionised* by the passage of Röntgen or similar rays, and this will take place with a much smaller expansion than is necessary to produce condensation if the rays are absent. In this case the charged ions appear to act as nuclei for the condensation of vapour.”



“An ion (atom + electron) can play the part of a condensation nucleus” (L. C. A. Bonacina).<sup>1</sup>

*Coloured Rain.*—Showers of grey, red, yellow, or black rain have been recorded from time to time. Luke Howard, in his *Climate of London* (1833), mentions a fall of chalky rain, which occurred “in the third region of *Mount Ætna*” on the morning of April 24, 1781. The ground was wet with a *coloured cretaceous grey water*. The grey matter “was an *oxide*, produced from a metallic base, or sublimate, ejected, along with a prodigious quantity of steam, from the bowels of the mountain, and condensed along with that into this singular mixed rain.”

In the chronicles of the Middle Ages “showers of blood” are often alluded to. The red colour was probably due to the *Protococcus nivalis*, a minute vegetable organism which causes the red snow of Arctic and Alpine regions. Occasionally, however, the colour was caused by the presence of an inorganic substance, such as ferric oxide.

Towards the end of 1896 a red dust fell heavily in Melbourne and over a considerable area of Victoria. A very clean sample of the dust was collected by Mr. W. E. Appleby, a resident of Moonee Ponds, and analysed by Mr. Thomas Steel, F.L.S., F.G.S., who found that it consisted largely of sand (66 per cent.), but ferric oxide was present to the extent of 4·68 per cent., and ferrous oxide to the amount of ·5 per cent.

L. F. Kämtz, in his *Meteorology* (1845), wrote: “Formerly, and even at the present time, flowers of sulphur have been said frequently to fall with rain. After heavy showers quiet waters were found covered with a yellowish dust, and, as it was easily inflamed, it was concluded to be sulphur. Every year the newspapers contained notices of it. More accurate researches have proved that this dust is nothing else than the pollen of certain flowers, and of pines in particular, which was swept off by the wind and precipitated with the rain. Elsholtz had said this as long ago as 1676.”<sup>2</sup>

<sup>1</sup> “Some of the Causes and Effects of Atmospheric Electricity” (*Symons's Meteorological Magazine*, vol. xli., p. 169, 1906).

<sup>2</sup> See a letter by Mr. H. Sowerby Wallis in *Symons's Monthly Meteorological Magazine*, November, 1886 (vol. xxi., p. 144).

In June, 1879, "showers of sulphur" were reported from various localities in the United Kingdom. Such a shower of yellow rain fell in Dublin, and on examining the resulting water with a low-power microscope, I found the cause of the colour to be merely pollen grains from some species of *Coniferæ*.

The late Dr. Alexander Buchan, F.R.S., in his *Handbook of Meteorology*, published in 1868, stated that "the black showers which occasionally fall in Scotland are in all likelihood the dust or scoriæ from the volcanoes of Iceland transported southwards." A more probable and reasonable explanation is that the black coloration of the falling rain was due to the presence of soot. In *Symons's Meteorological Magazine* for February, 1908 (vol. xliii., p. 2), Dr. Otto Boeddicker, observer at the Earl of Rosse's observatory at Birr Castle, King's Co., describes a "black rain" which fell over the central counties of Ireland, from Tipperary to Armagh, on October 8 and 9, 1907. Large quantities of soot were deposited in some places. At Lynbury, near Mullingar, Co. Westmeath, the deposit of soot in a recently-cleaned tank was sufficient to choke a  $\frac{1}{2}$ -inch pipe. A soot-laden cloud approached Birr from east-south-east about 2 p.m. of October 9. The last tidings of this cloud reached Dr. Boeddicker from Faelduff, twelve miles to the west of Westport, Co. Mayo, where it again discharged black rain "much darker than bog water." He considers that we have here evidence of a soot-laden cloud, originating probably in South Wales, crossing St. George's Channel and the whole of Ireland, and finally disgorging its soot into the Atlantic.

Mr. H. Sowerby Wallis, in a letter on "Remarkable Showers," published in *Symons's Monthly Meteorological Magazine*, November, 1886, quotes Sir J. F. W. Herschell, Bart. (*Meteorology*, 1862) as follows: "Showers of fish, frogs, flannel (matted *Confervæ*), bread (edible fungus), *Infusoria*, and other unaccountable substances, are among the more palpable evidences on record of the elevating and transporting power of whirlwinds."

Under the same heading, "Remarkable Showers," we find references in *Symons's Meteorological Magazine* from time to time to showers of "frogs" (July, 1842 or 1843, in Suffolk), "hazel-

nuts" (May 9, 1867, in Dublin), "sulphur"—*i.e.*, pollen (October, 1867, at Thames Ditton), "larvæ" (April 22, 1871, at Bath, and April 29 of the same year at Aldershot), "hay" (July 28, 1875, at Monkstown, Co. Dublin), "snails" (July, 1886, at Redruth, Cornwall), and "fish" (June 15, 1895, in Co. Clare).

"Red rain" fell in Sicily and many parts of Southern Italy on Sunday, March 10, 1901, alarming the peasants on account of its resemblance to blood. The red colour was proved, on examination by Professor J. W. Judd, to be due to dust or fine sand raised from the Sahara, and carried across the Mediterranean by a sirocco.<sup>1</sup> At the beginning of the same month the blood-rain plant—a motile alga named *Sphærella pluvialis*, closely allied to the better-known *S. nivalis* of red snow—was found by Dr. H. R. Mill in the large evaporation tank (6 feet square and 2 feet deep) at Camden Square, London, N.W. (See note on p. 264).

Before making a few remarks as to the Distribution of Rain, it may be well to say something about the other forms in which precipitation takes place—snow, sleet, and hail.

1. *Snow* consists of watery particles, frozen or congealed into crystalline forms of infinite variety and exquisite beauty. It is white or transparent, and entangles in its loose texture relatively large quantities of atmospheric air (about ten times its own bulk). To this last peculiarity snow owes its property of being a very bad conductor of heat, so that it protects the earth from the effects of terrestrial radiation in winter, the soil underneath it being at times 40° F. warmer than the superincumbent air. The white colour of snow is due to the blending of prismatic colours flashed from the countless surfaces of minute snow-crystals, as well as to the air entangled by these crystals; it is analogous to the whiteness of pounded glass or of foam. *Red snow* and *green snow* have been observed in the Arctic Regions and elsewhere. The coloration is due to the presence of minute micro-organisms,  $\frac{1}{10000}$  inch in diameter, called *Protococcus nivalis* or *Sphærella nivalis*.

In a beautiful word-picture Professor Tyndall describes a fall of snow which he witnessed on the summit of Monte Rosa as

<sup>1</sup> *Nature*, March 28, 1901.

“ a shower of frozen flowers. All of them were six-leaved ; some of the leaves threw out lateral rib-like ferns ; some were rounded, others arrowy and serrated ; some were close, others reticulated, but there was no deviation from the six-leaved type. Nature seemed determined to make us some compensation for the loss of all prospect, and thus showered down upon us those lovely blossoms of the frost, and had a Spirit of the Mountain inquired my choice—the view or the frozen flowers—I should have hesitated before giving up that exquisite vegetation. It was wonderful to think of, as well as beautiful to behold. Let us imagine the eye gifted with a microscopic power sufficient to enable it to see the molecules which composed those starry crystals ; to observe the solid nucleus formed and floating in the air ; to see it drawing towards it its allied atoms, and those arranging themselves as if they moved to music, and ending by rendering that music concrete. Surely such an exhibition of power, such an apparent demonstration of a resident intelligence in what we are accustomed to call ‘brute matter,’ would appear perfectly miraculous, and yet the reality would, if we could see it, transcend the fancy. If the Houses of Parliament were built up by the forces resident in their own bricks and lithologic blocks, and without the aid of hodman or mason, there would be nothing intrinsically more wonderful in the process than in the molecular architecture which delighted us upon the summit of Monte Rosa.”

A very elaborate series of 151 different forms of snow-crystals, drawn by Mr. James Glaisher, F.R.S., will be found in the Fifth Report of the Council of the British Meteorological Society (now the Royal Meteorological Society), published in 1855. The crystals are either hexagonal plates or six-pointed stars, with angles which are always multiples of  $15^\circ$  or  $30^\circ$ , so bearing a close relation to those of a regular hexagon (R. H. Scott).

Beautiful engravings of snow-crystals will be found in the *Philosophical Transactions* for 1742 (vol. xlii.), by Dr. Leonard Stocke of Middelburg, in Zealand ; and in the same publication for 1755 (vol. xlix.), by Dr. John Nettie, also of Middelburg. The latter series includes ninety-one different forms of crystals, which were observed in the intensely cold winter of 1740-41.



For modern work on snow-crystals we are indebted to Dr. G. Hellmann, of Berlin ;<sup>1</sup> Dr. G. Nordenskiöld, of Stockholm ;<sup>2</sup> but especially to Mr. Wilson A. Bentley, of Jericho, Vermont, U.S.A. In the *Monthly Weather Review* of the United States Weather Bureau for May, 1901, the last-named observer gives a sketch of his twenty years of study among snow-crystals, illustrating it by about twenty-five exquisite photomicrographs of snow-forms. In the Annual Summary of the same publication for 1902 (vol. xxx., No. 13, p. 607) Mr. Bentley published his "Studies among the Snow-Crystals during the Winter of 1901-02, with additional Data collected during Previous Winters." That winter proved to be extremely favourable for observing, and over 200 beautiful photomicrographs were obtained, showing snow-forms of infinite variety, which also greatly exceeded in beauty and interest the contributions of any other single winter.

The application of photography to this charming research, as was to be expected, has shown that many of the elaborate drawings of snow-crystals of former times were very misleading.

Mr. Bentley's monograph is illustrated by 22 plates, containing 255 different forms of snow-crystals. His original paper (May, 1901) has 3 plates, including 26 microphotographs selected out of 800.

Like snow, hoar-frost crystals are divisible into two fundamental classes or types—columnar and tabular.

*Snow-rollers.*—Dr. W. N. Shaw, Director of the Meteorological Office, communicated to the Royal Meteorological Society on February 19, 1908, a paper by Mr. Charles Browett on this subject.<sup>3</sup> At Ryton-on-Dunsmore, near Coventry, on the afternoon and evening of January 29, 1907, there were several storms of fine snow, which fell very evenly, and without drifting, to a depth of about 1½ inches. At 8 a.m. next day Mr. Browett noticed that the snow on the lawn to the east of his house was heaped up, as though someone had run with a spade in front of

<sup>1</sup> *Schneekrystalle*, Berlin, 1893.

<sup>2</sup> "Preliminart meddelande rörande en undersökning snokrystaller" (*Fören. i Stockholm Förhandlingar*, Bd. xv., Heft 3, 1893; Geological Society of Sweden, 146-158, Plates 5-26).

<sup>3</sup> *Quarterly Journal of the Royal Meteorological Society*, vol. xxxiv., No. 146, p. 87. April, 1908.

him. On going out he observed that the snow was cleared away to the bare grass (except for slight bars of snow across) in tadpole-like markings, the tails all pointing to N.N.W., the direction whence the wind had been blowing all night, and at the heads the heaped-up snow neatly turned over in a roll. In the discussion which followed the reading of the paper, Mr. H. Mellish said that he had frequently observed the phenomenon. He had looked at his thermograph in 1907 on three occasions when falls of light fluffy snow had been followed by a temperature just above freezing-point. On each of these occasions the minimum had occurred in the early evening, and had been succeeded by a considerable rise before midnight. It therefore appeared that a necessary condition for the formation of these snow-rollers was a temperature slightly above freezing following a rather low reading of the thermometer. (See Appendix V., p. 466).

Snowflakes vary in size to a remarkable extent. The largest are fully an inch in diameter, and are observed at a comparatively high temperature ( $32^{\circ}$ , or slightly above freezing-point), and when the air is very damp. The flakes are seldom less than  $\frac{1}{10}$  inch in diameter, but in an extremely cold, dry atmosphere they may not exceed  $\frac{7}{100}$  inch; they then form "snow-dust," the penetrating power of which nothing can resist when it is driven before a strong wind, as in the "blizzard" of North America.

The following definitions were agreed on at the meeting of the International Meteorological Committee held at Paris in September, 1885 :

*Drifting snow* (Germ., *Schneetreiben* ; Fr., *Chasse-neige*).

*Snowstorm* (Germ., *Schneeegestöber* ; Fr., *Tourmente de neige*).

If more than half of the country surrounding a station is under snow the following symbol is to be employed :  $\square$  (a square surrounding a star). (Munich Conference, 1891.)

When snow falls, its measurement demands constant attention on the part of the observer. Should the wind be high and temperature very low, drifting of "snow-dust" will be apt to vitiate the measurement. Snow will be blown out of the gauge on the one hand or drifted into it on the other. The depth of snow in a sheltered place, free from drifting, should be carefully

measured by a 2-foot rule. On a very rough estimate, 1 foot of dry snow may be taken to represent an inch of rain. The rain-gauge should be visited frequently during a snowstorm, and the snow carefully removed and thawed in a covered vessel protected from evaporation. If snow is not falling at the hour of observation, the gauge (funnel and receiver) may be brought indoors, when its contents will melt and may then be measured as rain. The funnel should be covered with a large plate to prevent loss by evaporation. It is also recommended to melt the snow in the funnel and cylinder of the rain-gauge suddenly by adding a known quantity of hot water, the amount of which should be deducted from the final measurement. In practice this plan does not work well, for the shrinkage of the water in volume caused by its rapid reduction of temperature introduces a considerable element of error into the calculation. In some gauges hot water is poured into an outer casing, and the snow is thawed in the funnel and cylinder without admixture with the water at all. This is an excellent plan, but requires a slightly more costly instrument, such as the snow-melting rain-gauge invented by Mr. James Sidebottom, F.R.Met.Soc. In this instrument the case is double, and warm water is poured into an angular tube, thus melting the snow. When the snow (with which the warm water is never in contact) in the funnel is melted, the water is run off by a tap, and, if needed, a fresh supply is added. By this arrangement any mistake from adding a wrong quantity of water is rendered impossible.

Should the snow have been lifted out of the funnel by the wind a good plan is to take the outside cylinder of the gauge, which has the same diameter as the funnel, and to insert it in the snow, where it lies level and of a uniform depth. The solid cylinder or section of snow thus cut out should then be melted, and the resulting water measured.

2. *Sleet* is half-thawed snow, or mingled snow and rain. It is of rare occurrence in rigorous climates, but is frequently observed in a British winter, and in the vicinity of large lakes or the open sea. Sleet is generally formed by falling through a stratum of air much warmer than that in which condensation has taken place and whence it has come. It is, therefore, just the opposite

of "frozen rain" or "silver thaw"—a phenomenon which occasionally happens in winter, particularly in connection with "glazed frost" (Germ., *Glatteis*; Fr., *verglas*). In this case raindrops, sometimes of large size, fall from clouds in a warm upper current into a stratum of air near the ground, the temperature of which may still be many degrees below freezing-point. The result is that the raindrops freeze before or when they reach the ground. They fall as particles, or pellets, or spicula of clear, transparent ice, and presently the surface of the ground becomes coated with ice, rendering locomotion on roads and footways well-nigh impossible.

On January 22, 1867, a "silver thaw" occurred in the south-east of England, which is thus described by Mr. G. J. Symons in the *Meteorological Magazine* for February, 1867: "At 7.10 p.m., the ground being then frozen and the temperature of the air below freezing-point, some rather sleety hail began to fall on the pavement; it crackled underfoot, and flattened out into diminutive lozenges. About 8 p.m. it turned to rain, although the temperature of the air was still several degrees below freezing-point, and the ground-temperature was about 24°. The necessary result was the coating of everything with a layer of ice. At 9 p.m. the temperature at 4 feet above the ground was 26.2°, and it was still raining, and the rain still freezing on pavement, walls, gravel walks, umbrellas—in fact, on everything. We never recollect being (meteorologically) more mortified than we were at the failure of all our efforts to reach the thermometers 20 feet above the ground; but climbing an iced pole was a feat beyond us, and we know not what was the temperature at that small elevation. . . . Of course, the streets were in a frightful state. . . . There was for some hours (till 3 a.m. in London) no safe mode of traversing the roads or pavements but the very novel one of skating."

In 1672 accounts reached the Royal Society of a remarkable "silver thaw" which visited Somersetshire and Oxfordshire early in December of that year, and caused great destruction of trees in plantations and orchards. One observer weighed the sprig of an ash-tree of just  $\frac{3}{4}$  pound. The ice on it weighed 16 pounds at least.<sup>1</sup>

<sup>1</sup> *Philosophical Transactions* (abridged), vol. i., pp. 455 and 478. London C. and R. Baldwin. 1809.



3. *Hail* (Germ., *Hagel* ; Fr., *grêle*), while as white as snow, is much denser than it, and often consists of a central nucleus of ice or condensed snow, with alternate deposits of hoar-frost and of ice surrounding it, the latter sometimes taking the form of pyramidal crystals. According to Dr. Marcet, the formation of hail requires (1) a large accession of moisture ; (2) a temperature below freezing-point ; (3) the presence of electrified clouds. Typical hailstorms are nearly always associated with thunder and lightning, and Mr. R. H. Scott says that Volta supposed that the hail pellets are kept in a state of constant oscillation between two oppositely electrified clouds, until by continued condensation the stones grow so heavy that at last gravity prevails, and they break through the lower stratum of the clouds and fall to the earth. Hail, strictly speaking, is a day phenomenon, and occurs when the air is warm near the ground, while the upper air is intensely cold. Under these circumstances, dense and electrical cumuli form, and from these clouds the hail descends. Such hailstones vary in size from a small pea to an orange or a goose egg. Before they fall all observers agree that a loud and continuous roar is heard, caused by the stones being dashed hither and thither in the air, either by electrical agency, as Volta thought, or, as seems more likely, by a cyclonic whirl of air in the vicinity of the storm-cloud. This is really Dove's theory. He held that hailstorms are always whirlwinds, but with their axes almost horizontal instead of vertical. I thoroughly endorse this view. It is supported by the behaviour of the barometer in what are called "thunderstorm depressions," by the cyclonic shifting of the wind in any ordinary summer shower, and by the phenomena attending spring tornadoes in North America and elsewhere. One of my earliest recollections is my having been an eyewitness of a tornado of this kind which devastated a part of Dublin on the afternoon of Thursday, April 18, 1850. The Rev. Dr. Lloyd, then President of the Royal Irish Academy, and afterwards Provost of Trinity College, Dublin, communicated a most interesting and graphic account of the tornado to the Academy four days after it occurred, of which the following is an abstract :

"The first indications of the approach of the storm were

observed soon after three o'clock. Massive *cumuli* were seen forming in the south-western portion of the sky. These became denser as they approached, until they formed a mass of an ash-grey colour, projected on a sky of a paler tint, while the rugged outliers from the mass, of the peculiar form (between *cirrus* and *cumulus*) which indicates a high degree of electrical tension, showed plainly that a storm was approaching. About half-past three o'clock it burst forth. The flashes of lightning (generally forked) succeeded one another with rapidity, and at length the roar of the thunder seemed continuous. Some persons who observed the phenomenon from a distance were able to distinguish the two strata of oppositely electrical clouds, and to see the electrical discharges passing between them.

"Hitherto the wind was light, and there was that peculiar closeness in the air which is the result of high temperature and excessive humidity. Shortly before four o'clock the rain commenced; this was followed almost immediately by discharges of hail, and at 4 p.m. the terrific tornado, which was the grand and peculiar feature of this storm, reached us.

"This gale, which appears to have been a true whirlwind, first sprung up from the south-east, driving the hail before it impetuously. It then suddenly, and apparently in an instant, shifted to the point of the compass diametrically opposite, and blew with increased violence from the north-west. The noise about this time of the shifting of the wind was terrific, and arose (as is conjectured respecting similar tropical phenomena) from the confused conflict of hail in the air. The size of the hailstones as well as the vehemence of the gale appeared to be greater during the second phase of the storm than in the first. These masses, many of which were as large as a pigeon's egg, were formed of a nucleus of snow or sleet, surrounded by transparent ice, and this again was succeeded by an opaque white layer, followed by a second coating of ice; in some of them I counted five alternations.

"In less than ten minutes the tornado had passed. The wind returned to a gentle breeze from the south-west, and the weather became beautiful."

Dr. Lloyd adds: "In the tornado, the vortex is of much smaller dimensions (than that of a cyclone or great revolving storm), and is produced by rapidly ascending currents of air, caused by the heating of a limited portion of the earth's surface under the action of the sun's rays. In the temperate zones, accordingly, it is never produced in winter. These ascending currents are loaded with vapour, which (owing to the rapid evaporation) is in a highly electrical state, and when they reach the colder regions of the atmosphere the vapour is condensed, and electrical clouds are rapidly formed."

In the park and garden of Trinity College nineteen trees were uprooted by the tornado, eleven being trees of large size. Ten fell from the south-east, or under the influence of the first half of the gale, and nine from the north-west. The bearings of the fallen trees were accurately taken, and showed that the main direction of the south-east gale was S.  $56^{\circ}$  E., and that of the north-west gale N.  $53^{\circ}$  W. The centre of the vortex, therefore, passed over the College Park.

The barometer fell from 29.964 inches at 1 p.m. to 29.930 inches at 4 p.m., rising again to 29.944 inches at 7 p.m.

From an unofficial return made by the Metropolitan Police, it appears that damage to the amount of £26,332 0s. 11d. was done in the city by the tornado, including the breaking of 388,635 panes of glass.

On the morning of August 31, 1891, Venice was devastated by a hailstorm, of which an eyewitness writes: "I never before realised how property can be destroyed, and personal injury inflicted, and even death incurred, by simple exposure for a minute or two to the blows of hailstones. Now I do. The storm came on with a suddenness that took us all by surprise. A few dark clouds coming over the city from the north and west, and a few flashes of lightning and rattling peals of thunder, and in a moment a tempest of hail was upon us. The awful noise made me think that the hurricane of wind that was raging was sweeping the roofs clear of their tiles and levelling chimneys to the ground. In part that was the case, but the noise was the noise of hailstones, solid pieces of ice as big as eggs, and some as big as oranges, that did not fall, but were being driven with terrific force on to the roofs of

the houses, on to the pavement, and into the water. . . . As they fell into the canal that goes by my door its usually quiet surface seemed to boil furiously. The storm was over in a few minutes, and I went out. Venice seemed to have suffered a bombardment. . . . The officials in the office of the *Adriatica* newspaper secured some of the hailstones as they fell, and had them weighed. Several weighed 250 grammes—that is, more than  $\frac{1}{2}$  pound. In some places the streets seemed to be covered with a bed of white stones.”

In cold weather in spring hail sometimes assumes another form, and falls from cumuli in pyramidal soft masses, like miniature snowballs. This is “*soft hail*” (Germ., *Graupel*; Fr., *grésil*). The front of the pyramid as it falls is convex; the remainder of the soft hailstone is either conical, when the whole resembles a tiny pegtop upside down, or pyramidal with a hexagonal or square base, as if it originally formed part of a large sphere of hail. Mr. H. A. Cosgrave, M.A., describes the former shape as having characterised hailstones which fell on July 3, 1877, at Kilsallaghan, Co. Dublin;<sup>1</sup> while W. T. Black figures the latter shape in an account of a heavy fall of hail at Leamington on March 31, 1876.<sup>2</sup> Hail of moderate size accompanies snow showers in winter, whether by day or by night, coming with northerly (north-west to north-east) winds. Tiny granules of hail also fall from the grey roll-cumulus of winter anticyclones, but never in large quantity. The international symbols distinguish between true hail,  $\blacktriangle$ , and soft hail,  $\triangle$ .

An attempt was made many years ago by Mr. G. J. Symons, in his *Meteorological Magazine*,<sup>3</sup> to determine the weight of hailstones in relation to their size. He gives a table which is based on the assumptions :

1. That the hailstones are truly spherical.
2. That they consist wholly of clear ice.

A cubic inch of water weighs 253 grains, but the specific gravity of ice is .93, therefore a cubic inch of ice cannot weigh more than 235 grains, or a trifle over half an avoirdupois ounce. Each

<sup>1</sup> *Symons's Monthly Meteorological Magazine*, vol. xii., p. 86.

<sup>2</sup> *Loc. cit.*, vol. xi., pp. 55, 56.

<sup>3</sup> Vol. xiv., p. 115. 1879.



·01 inch of rain in the measuring-jar of an 8-inch gauge contains 127 grains. Each ·01 inch in that of a 5-inch gauge weighs 50 grains. If, therefore, ten selected hailstones, when gradually melted in the measuring-glass of the 5-inch gauge, yield ·13 inch, we have :

$$\frac{13 \times 50}{10} \text{ grains} = 65 \text{ grains of water} = \text{the weight of each of the ten hailstones.}$$

A modern work on "Hail" is that from the pen of the Hon. Rollo Russell, F.R.Met.Soc., which was published in 1893 (London: Edward Stanford). The author concludes, as the result of a wide experience, that the clouds in which large hail has its origin are commonly at a great height, between 15,000 and 40,000 feet, or higher. These clouds are the result chiefly of expansion and refrigeration of warm humid air, of the sudden mixture of masses of air greatly differing in temperature and vapour tension, and of free radiation. The nucleus of a hailstone consists of a snowflake, pellet, or spicule, which falls from the uppermost cloud. The snowflake, pellet, or spicule, is electrified as a result of condensation, and as it falls attaches particles of ice and globules of water below the freezing-point to itself, the particles arranging themselves commonly in a stellate form, or concentrically round the nucleus. The variety of form of the primitive kernel is great, and consequently hailstones of many different shapes may be met with. The ordinary top-shaped hailstone is produced by the lower side growing more quickly than the upper, as it comes into contact with more particles; and since the impact is most forcible on the lower side, the ice of the spheroidal base is the hardest. Mr. Russell's book is illustrated by two photographs of hailstones (actual size) taken after a terrific thunderstorm at Richmond, Yorkshire, on July 8, 1893, by Mr. H. J. Metcalfe, photographer, High Row, Richmond, Yorks. Some of the hailstones figured have a diameter of 2 inches.

The recent literature on the "building of hail" includes the following :

1. "Die Bildung des Hagels," by Wilh. Trabert. *Meteorolog. Zeitschrift*, pp. 433-447. October, 1899.
2. "Beiträge zur Hageltheorie," by P. Schreiber. *Meteorolog. Zeitschrift*, pp. 58-70. February, 1901.

3. *Lehrbuch der Meteorologie*, by J. Hann, pp. 682-699. 1901.

4. "Hailstones," by F. W. Verz. *Trans. Acad. of Science and Art*, Pittsburg. (A lecture delivered January 5, 1904.)

5. "Studies on the Thermodynamics of the Atmosphere," by Professor Frank H. Bigelow. *Monthly Weather Review*, U.S. Weather Bureau, vol. xxxiv., No. 11, pp. 514-517. November, 1906.

Professor Bigelow considers that hail is formed at the rear of the rising column of warm air in the front of a storm, at a place of marked changes in the isotherms, when the barometer is beginning to rise rapidly, and the wind shifts from south to north-west. This is the site (*locus*) of the contact of two counter-currents of air having very different temperatures, and hail formation is one of the results of the rapid progress of the warm and cold layers towards thermal equilibrium. He discusses five distinct theories of the formation of hail, in each of which there is probably an element of truth: (1) The oscillation theory, (2) the orbital theory of Professor William Ferrel,<sup>1</sup> (3) the upward current theory, (4) the electrical attraction theory, and (5) what he calls the stratification theory. According to this (Bigelow's) theory, a hailstorm cloud consists of two component portions, separated from each other by isothermal surfaces inclined forward from the vertical. On the front side the air is much warmer than on the back side, and along the line of separation the contour is strongly stratified by the mutual interpenetration from opposite directions of layers of air having different temperature.

*Distribution of Rain.*—This topic may be considered under the headings—geographical and seasonal.

The hyetal (Greek, *ἕτερος*, rain) equator is the line separating areas whose rainfall follows the seasons of the Northern Hemisphere from those whose rainfall follows the seasons of the Southern Hemisphere: This line is south of the geographical equator in the east, and north of it to the west of the continents (A. Supan).

I. *Geographical*—1. *British Islands.*—Thanks in great measure to the energy and organising power of Mr. G. J. Symons, F.R.S., and of his very able colleague and successor, Dr. Hugh Robert Mill, the United Kingdom is now covered with a network of rain-gauge stations, upwards of 4,500 in number in 1908, and the

<sup>1</sup> "Recent Advances in Meteorology," Appendix 71, *Annual Report of the Chief Signal Officer for 1885*, part ii., pp. 302-315.

observations are digested and published in *British Rainfall* each year under the personal supervision and editorship of Dr. Mill. Mr. Symons's coloured rainfall map gives the leading facts in a striking and intelligible form. The average annual rainfall *as a rule* decreases from west to east, both in Ireland and in Great Britain. It exceeds 75 inches in the West of Scotland (151 inches on an average of fifteen to eighteen years at the dismantled Ben Nevis Observatory), the English Lake District, in the mountains of North Wales, and on the top of Dartmoor in Devonshire. Seathwaite in Borrowdale, at the south end of Derwentwater, has an annual fall of 137 inches on the average of fifty years; near Sty Head above it the mean fall is 177 inches, or some 15 feet, rising in wet years above 200 inches, or 17 feet. In Ireland the rainfall is heaviest on Mangerton, in the neighbourhood of Killarney (about 86 inches, based, however, on only eight years' average), at Kylemore, in Connemara (mean for fifteen years being 77·6 inches), smallest in and about Dublin (about 28 inches) and in the Co. Down. On the East Coast of England it falls well below 25 inches. Spurn Head, Yorkshire, on an average of ten years, had only 19·1 inches; and Shoeburyness, in Essex (in twenty-five years), 20·6 inches.

The reason for this distribution is that westerly winds are those which prevail most in the British Islands. They reach the mountainous western coasts off the Atlantic, and laden with moisture in consequence, are forced upwards above the saturation line. When these prevalent winds reach the eastern seaboard they have already lost a great deal of their moisture through condensation, and they are *descending*—a state of things which raises their temperature and increases their capacity for vapour. They are then like the dry, warm, south wind of the northern slopes of the Alps, which is called the *Föhn* in Switzerland. The *Chinook*, or warm westerly wind of the Canadian prairies east of the Rocky Mountains, has a similar controlling effect on the rainfall of the Province of Alberta.

2. In *Foreign Parts*, the *wettest* regions are the Equatorial zone of calms over the Atlantic and Pacific Oceans, and "localities where damp winds meet mountain ranges and are forced upwards" (R. H. Scott). Examples of the latter are the Khasi Hills in Assam (Cherra Poonjee, or Cherrapunji, 464 inches as the mean of thirty-three years), the Western Ghâts in India (Mahabaleshwar,

269 inches, the mean of forty years), the western coast of Norway (Bergen, 73 inches on an average of twenty-five years), Sitka in North-West America, Valdivia in Southern Chili, and Hokitika in New Zealand. The *driest* regions are the Sahara, Egypt, Arabia, and Persia, the southern *steppes* of Russia, the North-West of India (Jacobabad, on the Upper Sind Frontier, has only 4.1 inches per annum), the Great Salt Lake region in North America, the Kalahari Desert in South Africa, the interior of Australia, and Peru and Northern Chili between the Andes and the sea in South America. The desert of Gobi, in Central Asia, is rendered almost rainless by intercepting chains of lofty mountains.

II. *Seasonal*.—On the western shores of Europe the winter rainfall exceeds that of summer in persistence and amount. This is due to the prevalence of westerly winds, and to the coldness of the highlands near the Atlantic seaboard. In winter the rains mainly accompany cyclonic storms. Rain falls most heavily along the western coast-line, as the isotherms run almost parallel to it and perpendicular to the prevailing winds (Drs. A. Angot and A. J. Herbertson). On the continent of Europe the summer rainfall exceeds that of winter, at all events in amount. This is doubtless in consequence of the torrential rains which accompany summer thunderstorms. In fact, as Dr. R. H. Scott puts it, *the rains of low latitudes are essentially summer rains*, as they occur principally when the sun is highest. Another good name for them would be “evaporation rains,” because they fall from cumuli which have been formed by local evaporation and the ascent of the vapour above the saturation or condensation line. The great Indian rains accompany the south-west monsoon—that is, they are caused by the condensation of the vapour-laden winds blowing from the Indian Ocean.

In Dublin the monthly rainfall, on an average of forty years, 1866-1905, is least in April (1.913 inches) and June (1.912 inches), greatest in August (3.130 inches) and October (2.803 inches).

The wettest month in most parts of England and the East of Scotland is October; in the West and North-West of Scotland, however, it is December or January; and in the East of England July or August.

III. The *diurnal* fall of rain is determined by the seasons. As a rule, in winter more rain falls by night than by day; in summer,



more rain falls by day than by night. At ordinary British stations falls more than 2 inches in the twenty-four hours are not common. In Dublin, since 1865, such a fall has occurred only on nine occasions: August 13, 1874 (2·482 inches); October 27, 1880 (2·736 inches); May 28, 1892 (2·056 inches); July 24, 1896 (2·020 inches); August 5, 1899 (2·227 inches); August 2, 1900 (2·135 inches); November 11, 1901 (2·037 inches); September 2, 1902 (2·075 inches); and August 25, 1905 (3·436 inches). This last excessive rainfall is especially noteworthy. On no previous or subsequent occasion within the past forty-five years have 3 inches or upwards of rain been measured as the product of twenty-four hours in the city of Dublin. But these downpours pale into insignificance before the record rainfalls of the world, of which, perhaps, the most notable is that which wrought such terrible ruin in Brisbane at the beginning of February, 1893. In the Blackall Ranges, near the city of Brisbane, 77·305 inches of rain fell in the four days ending February 3, 35·714 inches being the measurement on February 2. But this fall, tremendous as it is, does not stand out as a world's record, for on June 14, 1876, 40·80 inches of rain fell within twenty-four hours at Cherrapunji, Khasi Hills, Assam, being at the rate of 1·7 inches per hour.<sup>1</sup>

*Weight and Bulk of Rain.*—When we speak of an inch of rain, we mean that sufficient has fallen to fill to overflowing a vessel which is 1 *inch in length*, 1 *inch in breadth*, and 1 *inch in depth*—that is, a volume of 1 *cubic inch*. Now, an acre contains 6,272,640 square inches, each of which would receive an inch depth of rain if the rainfall was 1 inch. One inch of rain over an acre is therefore 6,272,640 cubic inches. But, according to recent determinations,<sup>2</sup> 1 imperial gallon contains 277·123 cubic inches. So that—

$$\frac{6,272,640}{277\cdot123} = 22,635 \text{ gallons; or } 101 \text{ tons } 0 \text{ cwt. } 3 \text{ qrs. } 26 \text{ lbs.}$$

In round numbers, therefore, a rainfall of 1 inch means a downpour of 101 tons of water on every acre. As there are 640 acres in a square mile, a rainfall of 1 inch means a precipitation of 64,640 tons of water on every square mile.

<sup>1</sup> Professor John Eliot, "The Rainfall of Cherrapunji." *Quarterly Journal of the Meteorological Society*, vol. viii., pp. 47, 51. 1882.

<sup>2</sup> *Table-Book*, p. 35. By Rev. Isaac Warren, M.A. Longmans, Green and Co. 1888.

“*Blood-rain*” due to a *Dust-fall*.—On February 21 and 22, 1903, a remarkable dust-fall occurred over the whole of the South of England, the greater part of Wales, the Low Countries, the German Empire, and Switzerland. The dust fell over nearly all parts of England and Wales south of a line drawn from Anglesey through Wrexham and Northampton to Ipswich. The area over which dust fell comparatively thickly in England and Wales was certainly not less than 20,000 square miles, and the total quantity of deposit in England alone has been roughly estimated at not less than 10,000,000 tons. The dust usually attracted attention either as a dense yellow haze, or as a reddish-yellow powder, lying thickly on trees or roofs. In some instances it fell as a dry powder; in others it was noticed in the form of drops of muddy rain. The fall was often accompanied by temperatures considerably above the average, and by remarkably low relative humidities; at Uccle, near Brussels, for example, with a dry-bulb temperature of  $58^{\circ}$ , the relative humidity was only 32 per cent. of saturation. At a meeting of the Royal Meteorological Society on November 18, 1903, Dr. H. R. Mill, D.Sc., and Mr. R. G. K. Lempfert, M.A., read a paper on this great dust-fall. In this paper the authors attempted to trace the origin of the dust which was brought to our islands by a south-west wind. With the help of a series of daily weather charts, trajectories were drawn for the air which reached the North-West of Europe on the morning of February 22. Four trajectories were obtained. They seem to show that the air which reached the British Isles on the morning of the 22nd was derived from three sources: The North of Scotland, where temperature was low, was supplied with air from the Northern Atlantic; Ireland, and the North of England were deriving their air from the Central Atlantic; while over Wales and the South of England, apparently, air was being derived from the North-West Coast of Africa.

Appended to the communication of Dr. Mill and Mr. Lempfert is a note on the microscopic characters of this “blood-rain,” by Mr. John S. Flett, M.A., D.Sc. He concluded that the only part of the dust which could reasonably be supposed to have come from beyond the British Isles was an exceedingly fine reddish clay, none of the particles of which could greatly exceed  $\cdot 01$  millimetre ( $\cdot 0004$  inch) in diameter.

## CHAPTER XIX

### ANEMOMETRY AND ANEMOMETERS

WIND is air naturally in motion with any degree of velocity ; it is a current of air. Wind is produced by differences of atmospheric pressure, and these differences are in turn referable to—indeed, largely dependent on—variations in temperature. It has already been shown that the *force* of the wind is governed by the steepness of barometric *gradients*—in other words, by the closeness to each other of the isobars, or lines of equal atmospheric pressure. All mechanical obstacles, however, interfere with the velocity or force of the wind—for these two terms come to mean the same thing, owing to the substantial nature of the air—and, accordingly, we find that in general the force of the wind is greater at sea than on dry land, at a distance above the earth than on the surface of the ground—that is, in what is now called “the free air”—on the sea-coast than at an inland station, on the slope or summit of a mountain than on a plain, on a bare plain than in a wooded or hilly district.

In the *Narrative of a Voyage to the Southern Atlantic Ocean in the Years 1828-30, performed in H.M. “Chanticleer,” Captain the late Henry Foster, F.R.S.*,<sup>1</sup> Mr. W. H. B. Webster, surgeon, R.N., stated the general principles of the relation of wind to atmospheric pressure, and foreshadowed Buys Ballot’s Law. His remarks were based on personal observation of the singular difference between the mean height of the barometer at the Cape of Good Hope and at Valparaiso, on the coast of Chili (about 30 inches), and that at Cape Horn, Staten Island, and New South Shetland (29·3 to 29·4 inches). He says :<sup>2</sup> “If

<sup>1</sup> From the *Private Journals of W. H. B. Webster*, 2 vols. London, 1834.

<sup>2</sup> *Op. cit.*, vol. i., p. 316.

we suppose that at any time the barometer is high at one place and low at the other, we shall have at Cape Horn the barometer at 28·3 inches, while at Valparaiso or the Cape it will be at 30·6 inches, being an occasional (nay, frequent) difference of more than 2 inches. Now, if we consider these changes to take place principally in the lower strata of the atmosphere, which in fact must be the case, and that they range within the limits of five or six miles' altitude, how great must be the difference of the weights and pressures of the reciprocal columns. It is not surprising, then, that there should be continual gales endeavouring to restore the equilibrium. From the foregoing statements it may be safely inferred that 'the mean height of the barometer at the level of the sea being the same in every part of the globe' is by no means correct; but, on the contrary, that every place has its own peculiar height of the barometer; and to this permanent variation, a circumstance not heretofore recognised, may be attributed the perpetual interchange and motions of the atmosphere."

In this connection it may be incidentally mentioned that it is the steep gradient over the immense Southern Ocean which gives rise to the strong and gusty anti-trades or westerly winds which blow in the "Roaring Forties" of that ocean, and which prevail as far south as lat. 50°.

The oldest method of observing wind is by sensation or by estimation. It is a rough but ready method, and in the hands of a skilled observer yields fairly satisfactory results.

The earliest attempts at estimating wind *force* were doubtless made by sailors, from whom we have learned the expressions: a "gale," a "whole gale," a "squall," a "strong breeze," a "capful of wind," a "light breeze," a "dead calm." It has been already stated that such expressions were reduced to a scale by Admiral Sir F. Beaufort in 1805, whose Table of Wind Force (revised) is printed at p. 39 of this book. The nautical part of this table is of little use to a landsman, and, accordingly, the equivalent velocities and pressures have been calculated at the Meteorological Office, London, and included in the table. The mean velocity in English miles per hour being known, the equivalent velocities according to the metric scale—*i.e.*, in metres



per second—are obtained by multiplying the figures in the fifth column—that is, the number of English miles—by the factor .447. The scale of velocities included in the table must, however, be regarded as merely provisional, and as applicable chiefly to coast stations. At inland stations the velocity corresponding to a given force is much smaller, because the *general motion* of the air is retarded by inequalities in the surface of the ground, while wind force is naturally estimated from that of the *gusts*.

*Wind Direction.*—By this term is meant the point of the compass *from* which the wind is blowing. It may be ascertained by observing for a few moments the movements of a properly set and freely movable vane or weathercock. Chaucer has it—

“As a *wedercock* that turneth his face with every wind.”

When a weathercock is not available, the drift of the smoke from exposed chimneys should be carefully noted. *Under all circumstances*, the bearings should be true and not magnetic (by compass). In the British Islands the *variation* of the compass at the present time ranges from 15° in the extreme east of England to 22° in the extreme North-West of Ireland—the magnetic north lying so many degrees to west of the true north, or the true north so many degrees to east of the magnetic north. Roughly speaking, a true north and south line lies along the line north-north-east to south-south-west by compass. Accordingly, we get the following table for the conversion of directions observed by mariner's compass in the United Kingdom to approximate true bearings :

Compass Bearings.	True Bearings.
North	North-north-west
North-north-east	North
North-east	North-north-east
East-north-east	North-east
East	East-north-east
East-south-east	East
South-east	East-south-east
South-south-east	South-east
South	South-south-east
South-south-west	South
South-west	South-south-west
West-south-west	South-west
West	West-south-west
West-north-west	West
North-west	West-north-west
North-north-west	North-west

In the absence of a mariner's compass, we can ascertain the north point by means of the pole star, or the south point by means of the sun. The pole star, Polaris, is practically due north in January and July at 6 a.m. and 6 p.m., in February and August at 4 a.m. and 4 p.m., in March and September at 2 a.m. and 2 p.m., in April and October at noon and midnight, in May and November at 10 a.m. and 10 p.m., in December and June at 8 a.m. and 8 p.m. In order to ascertain the position of due south, we must know the longitude of a given place, and also the *equation of time*, or the difference between mean and apparent time—that is, the difference between the time of day indicated by the sun's position on the meridian and that indicated by a perfect clock going uniformly all the year round. As a matter of fact, the sun is not always on the meridian at 12 o'clock noon. It was so in 1909 on April 16, June 15, September 1, and December 25; but on November 2, 3, and 4 it reached the meridian 16 minutes 21 seconds before noon, and on February 10, 11, and 12 it was 14 minutes 25 seconds late, not arriving at the meridian until 0 hour 14 minutes 25 seconds p.m. Greenwich time is converted into local time by *subtracting* four minutes for every degree of west longitude, by *adding* four minutes for every degree of east longitude. Thus, noon at Greenwich becomes 11 hours 35 minutes a.m. in Dublin, the longitude of the Irish capital being  $6^{\circ} 15'$  west ( $6^{\circ} \times 4 \text{ m.} = 24 \text{ m.} + 1 \text{ m.} = 25 \text{ m.}$ ). In *Bradshaw's British Railway Guide* a map gives longitude from Greenwich in time direct, without calculation.

A "windrose" may be constructed "by calculating the percentage proportion of the number of wind observations from each point of the compass, and printing the results either in a tabular form or representing them by a diagram. Windroses may be made to show the force, as well as the direction, of the wind from different points" (R. H. Scott).

The Meteorological Congress at Vienna, in 1873, decided that, in the construction of windroses, winds of velocity less than  $\frac{1}{2}$  metre per second (one mile per hour) were to be disregarded, and counted as calms. A year previously, at Leipzig, it was arranged by the Meteorological Conference that calms should be enumerated separately, and designated by a special abbreviation,

such as the letter "C." The accepted abbreviation at present is the letter "Z," standing for force 0, or zero.

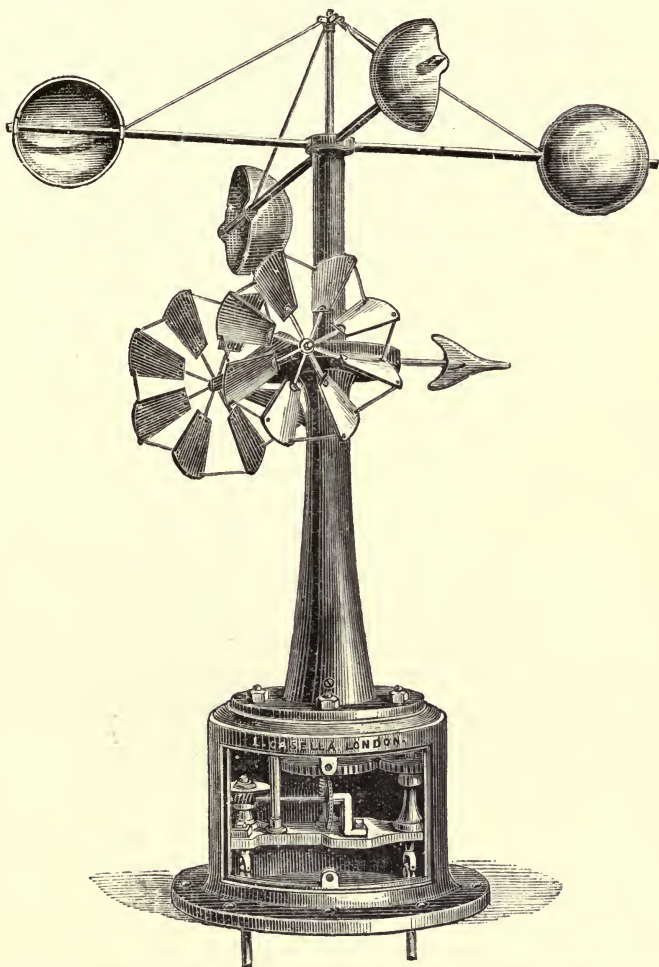

FIG. 71.—CASELLA'S SELF-RECORDING ANEMOMETER OR ANEMOGRAPH (see p. 289).

*Anemometers.*—The history of mechanical anemometry (Greek, *άνεμος*, *wind*; *μέτρον*, *a measure*) may be held to date from the year 1667, when the Royal Society published a revised

edition of "Master Rooke's" *Directions for Seamen*. The editors were Dr. Hooke and Sir Robert Moray, who say, *inter alia*, "The strength of the wind is measured by an instrument such as is represented." The representation shows a plate suspended by a bar from a pivot, and thus able to swing upwards when pressed by the wind along a graduated quadrant, the quadrant itself, with the plate, turning freely as a vane on a vertical shaft.

On March 15, 1882, Mr. J. K. Laughton, M.A., F.R.G.S., read his presidential address to the British Meteorological Society, entitling it a "Historical Sketch of Anemometry and Anemo-

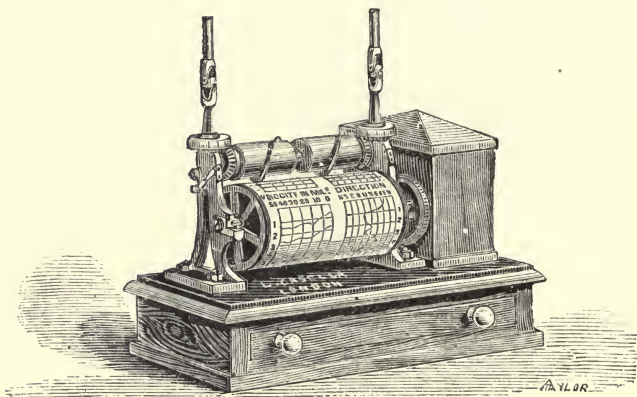

FIG. 72.—RECORDING CYLINDER OF CASELLA'S ANEMOGRAPH (see p. 289).

meters."<sup>1</sup> To this address I am indebted for the foregoing information, as well as for the following classification of anemometers :

A. *Pendulum*.—Such as Hooke's (1667), Pickering's anemoscope (1744), Dalberg's (1780), Schmidt's, of Giessen (1828), Wild's (1861), Howlett's (1868). The Vienna Congress (1873) recommended the introduction of Professor Wild's gauge, which is in use in Russia and Switzerland. It consists of a rectangular plate hung on hinges on a horizontal axis. The angle which this makes with the vertical indicates the force of the wind. This

<sup>1</sup> *Quarterly Journal of the Meteorological Society*, vol. viii., No. 43, p. 161. 1882.



instrument measures the force of light winds accurately, but fails in the case of strong winds, because the plate will be kept almost horizontal by even a moderate breeze.

B. *Bridled*.—Wolf (1708), Leupold (1724), Leutmann (1725), Beaufoy (1821), Francis Galton's "torsion anemometer" (1879), in which a set of Robinson's cups are bridled by a spring on a vertical shaft; Ronalds (1844), Stokes (1881). In Sir F. Ronalds's instrument the force of the wind is determined by means of a simple balance.

C. *Pressure Plate*.—Bouguer's (*Traité du Navire*, 1746), in which a piece of cardboard, 6 inches square, was fixed perpendicularly on to a light rod, which pressed into a tube against a spring; Abbé Nollet (*L'Art des Expériences*, 1770); Osler's (1836), in which the plate was separated from the wedge-shaped vane, and acted on a wire passing down the hollow spindle of the vane. In this way Mr. Osler obtained two distinct registers—one of direction, the other of pressure. Mr. Osler more recently adapted a windmill vane to give direction instead of the original wedge-shaped vane.

Jelinek (1850), in order to avoid the vacuum behind the pressure plate, cased it in by a cylinder, closed behind, against which it bore by three spiral springs. Cator (1864) made the back of the plate the base of a cone, and received the pressure on a system of levers instead of a spring. Professor Wilke, of Stockholm (1785), described another form of pressure anemometer, which he called an Anemobarometer. Pujoulx (1830 ?) adopted the same plan in causing the pressure to act on a bladder containing air, which by means of a double siphon-shaped tube forced a column of coloured liquid to rise.

The principle of the pressure plate anemometers is shown in the drawing on the following page (Fig. 73) used to illustrate Mr. Dines's anemometer comparisons at Oxshott (*Quarterly Journal of the Royal Meteorological Society*, vol. xviii., No. 83, July, 1892, p. 165 *et seq.*).

*Dines's Patent Pressure Portable Anemometer*.—This instrument meets a want long felt in the shipping interest; it is very compact, and with moderate care is not likely to be damaged

or get out of order. It shows accurately the force of the wind, the scale having been calibrated by direct experiment.

To use the anemometer, hold the case and pull up the projecting nozzle as far as it will go. The case then forms a convenient

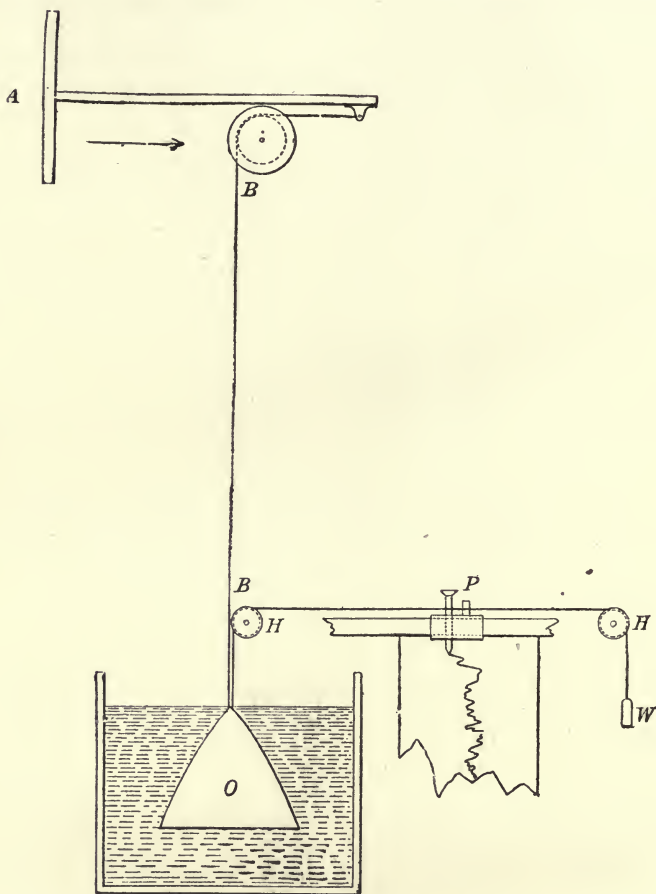

FIG. 73.—PRESSURE PLATE ANEMOMETER.

handle. Unscrew the milled head at the top a few turns, and hold the instrument in a vertical position, with the nozzle facing the wind. The velocity is then shown on the scale by the height

of the coloured liquid in the glass tube. Before replacing in its case and putting away, screw down the milled head gently until the rubber washer inside seals the end of the glass tube, taking care not to screw too hard for fear of breaking the glass.

When using the instrument, be careful to choose a fully exposed situation, and stand facing the wind, holding it at least 1 foot in front of the body. The nozzle should face the wind as nearly as possible, but the registration is not affected so long as it points within  $15^{\circ}$  to  $20^{\circ}$  of the right direction.

If bubbles get accidentally formed in the glass tube, they may be dislodged by gently sucking the nozzle.

When the milled head is unscrewed and the instrument is held vertically in still air, the liquid should stand at zero. If it does not, a little must be added or subtracted to make it do so; but the anemometers are sent out with the right amount of liquid in them, and there is no reason why this adjustment should be required.

It is desirable, though not necessary, to keep these instruments with the upper end of the scale highest; hence a loop has been provided, so that they may be kept hung on a nail. The milled head should be screwed down before the instrument is removed from the vertical position. This instrument is made by L. Casella.

*D. Pressure on a Fluid.*—Lind's (1775) anemometer consisted of a Pitot's or U-tube, swinging freely on a vertical spindle, so as to form a direction vane (Fig. 75). The tube nearer the spindle was bent back at right angles, so as to present its mouth to the wind, which, acting on water in the bend of the tube, forced it up the other leg of the U, the difference of level giving a measure of

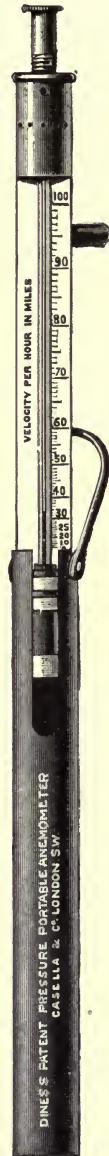

FIG. 74.—DINES'S PATENT PRESSURE PORTABLE ANEMOMETER.

the wind force. Wollaston (1829) modified this principle in the construction of his "differential barometer." Adie (1836) caused the air to blow down a bell-mouthed tube, led into the inside of a cylinder, air-tight above, but open below, which floats in a vessel containing water. This small "gasometer" rises as the pressure of the air inside is increased.

### E. Velocity.

1. Wheel with axis, horizontal or vertical, perpendicular to the direction of the wind. Lomonosow (1751).

2. Windmill sails, or fan, with axis in the direction of the wind. Woltman (1790); Whewell (1837); Rev. W. Foster (1844).

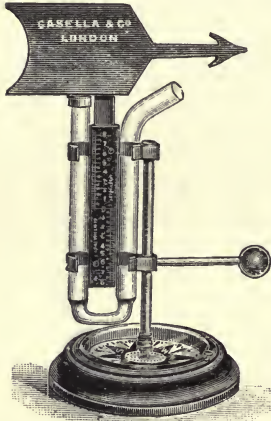

FIG. 75.—LIND'S ANEMOMETER.

3. Hemispherical cups (Fig. 76). The Rev. W. Romney Robinson, D.D., in 1846 applied a fact, "which," he said, "he had learned from the late Richard Lovell Edgeworth, that if hemispherical cups be carried by horizontal arms attached to a vertical axis, with their diametral planes vertical, they constitute an effective windmill, which he (Dr. Robinson) had found revolves with one-third of the wind's velocity." "To the bottom of the axis is attached wheel-work actuating a revolving disc, which rotates through a degree for every mile traversed by the wind."

The principle of this anemometer is based entirely on the difference of the wind pressure on the concave and convex sides of the cups. Dr. Robinson adopted 3 as a general and constant co-efficient to express this ratio. It is now known that the original "constant" of 3, as settled by the inventor, is far too high. The co-efficient 2.5 was proposed by Professor Sir George Stokes, Bart., in a paper in the *Proceedings of the Royal Society* (vol. xxxii., p. 170), but Mr. Laughton considers that this is only an approximation, and ought in strictness to be changed for each individual instrument and every different wind. The Kew authorities have finally decided to use the figure 2, and



Mr. Dines's experiments, referred to later on, indicate that at times 1.85 is nearer the truth (see p. 287 *et seq.*).

Dr. Robinson's anemometer is described in the *Transactions of the Royal Irish Academy* for 1850. The readings on the dials of this anemometer are as follow: One complete revolution of the *first* stamped index-wheel equals  $\frac{1}{10}$ th of a mile; the *second*, 1 mile; the *third*, 10 miles; the *fourth*, 100 miles; the *fifth*, 1,000 miles. Necessarily, in noting such reading, it must be done backwards, according to the indications on the instrument. The cups travel at a rate equal to one-third that of the wind; but allowance having been made for this in graduating the circles, a

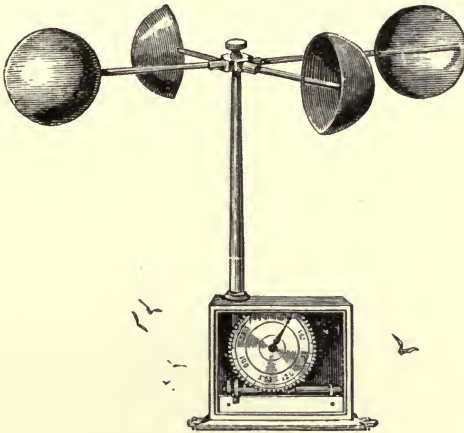

FIG. 76.—ROBINSON'S ANEMOMETER.

true reading is at once obtained. Negretti and Zambra's Improved Robinson's Anemometer (Fig. 77), as described by Colonel Sir H. James, R.E., F.R.S., has two graduated circles. The outer circle is graduated into five miles, each divided into tenths, and the inner circle from 5 to 505 miles. The velocity of the wind at any particular moment is found by observing this index before and after a certain interval of time—as one or five minutes—and then multiply the rate by sixty or twelve to find the velocity in miles per hour.

In recommending a modification of Robinson's cup anemometer, which he calls the "Step" anemometer, Mr. Walter Child points

out that the shortcomings of "the Robinson" are two—its results apply only to the motion of one thin, horizontal stratum of air, and they are, as is nowadays well-known, vitiated by the "sheltering error." This is especially the case with high winds. The cups in their revolution set the contiguous air in rotation in the same direction. In this way the resistance to the motion of the cups is lessened—an effect which culminates in a gale. The instrument, on this account, registers what actual wind there is at too high a velocity. Also, when the wind drops, the instrument runs on by the inertia of its part, and so registers

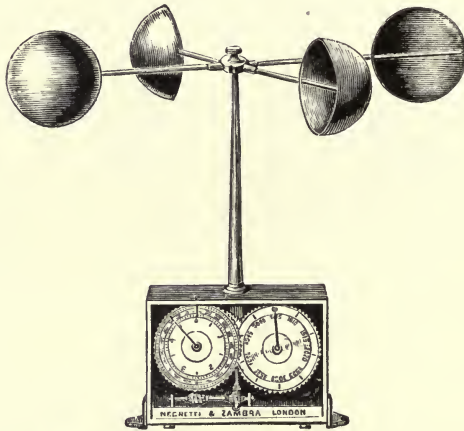

FIG. 77.—NEGRETTI AND ZAMBRA'S IMPROVED ROBINSON'S ANEMOMETER.

wind when there is none. This may be called the error of "over-running."

In order to obviate these drawbacks, Mr. Child arranges the four cups of the Robinson anemometer no longer at the same level, but in tiers or "steps" one above another, though at right angles as before.

The "Step" anemometer was tried at Kew Observatory, and yielded results which were some 25 per cent. less than the standard. This discrepancy, so Mr. Child submits, is the "apparent" measure of the "sheltering error" of the standard at the wind velocities under notice.<sup>1</sup>

<sup>1</sup> *Quarterly Journal of the Royal Meteorological Society*, vol. xxxiii., No. 144, p. 295. October, 1907.

4. Current meter. In a portable magnetic anemometer and current meter for maritime use, designed by Mr. R. M. Lowne in 1874,<sup>1</sup> the measurement of a current of air or water is effected by the revolution of a wheel carrying a number of plates of very thin aluminium, so arranged that their flat surfaces lie at an angle of  $45^\circ$  to the plane of the wheel's motion. When a wheel so formed is placed in a current, it revolves in a given time a number of turns that exactly express the velocity of the current which passes the wheel. The number of the revolutions of the wheel is indicated by pointers turning on a dial, and traversing circles on which the lineal feet of the current are expressed by graduations and figures.

At the suggestion of the late Sir Edmund Parkes, F.R.S., of the Royal Victoria Hospital, Netley, Mr. Casella, of London, constructed an air-meter for measuring the velocity of currents of air passing through mines, hospitals, and other public buildings (Fig. 78).

F. *Evaporation or Temperature.*—These anemometers are based on the principle enunciated by Leslie in his *Experimental Inquiry* (1804), that “the refrigerant power of a stream of air is exactly proportional to its velocity. Hence we may determine the rate of cooling that corresponds to any given velocity.” Leslie’s anemometer is a thermometer with a bulb larger than usual. Sir David Brewster (1829) adopted the principle that “when water is exposed to wind, the quantity evaporated in a given time is proportional to the velocity of the wind, the capacity of the air for moisture remaining the same. His anemometer consisted of a light frame, on which was stretched a surface of sponge

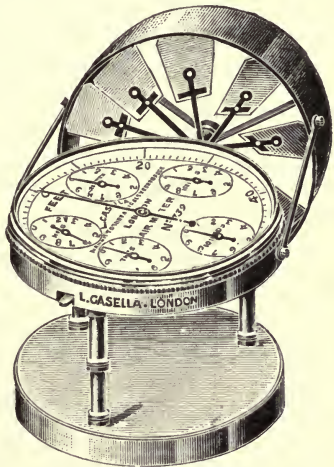

FIG. 78.—AIR-METER.

<sup>1</sup> *Quarterly Journal of the Royal Meteorological Society*, vol. ii., p. 285-1874.

or coarse flannel to be wetted. This frame was fixed perpendicularly on a light horizontal rod, pivoted on an upright spindle, round which it turned so as to face the wind. On the other arm of the rod was a sliding weight, the rod being graduated as a steelyard. The observed loss of weight gave a measure of evaporation, and so of the wind's velocity. Phillips (1848-49) re-invented the methods of calculating the velocity of the wind from its power of cooling or evaporating.

G. *Suction*.—Anemometers coming under this heading are based on a principle, first illustrated by Bernoulli about 1738, that the friction of masses of fluid in motion induces a power of suction as a result of the production of a partial vacuum. Professor Overduyn, of Delft (1854), and M. Bourdon (1882) applied this principle to the measurement of wind. G. A. Hagemann (1876) designed two anemometers, one for stationary observations, the other for observations on board ship or when travelling. The latter combines the pressure with the suction principle; the former adopts the suction principle only.

In his anemometer for stationary use, Hagemann<sup>1</sup> uses only the rarefaction produced by the wind on an open perpendicular tube. This tube is usually a piece of ordinary gas-pipe,  $\frac{1}{4}$  to  $\frac{1}{2}$  inch in diameter, and is fastened either to a mast or on a prominent place, such as a high chimney or a church tower. The pipe has at the top a gilt brass mouthpiece, with an opening of not less than 3 millimetres. It is carried down to the anemometer, properly so called, which consists of a vessel about half filled with pure water. From the bottom of this vessel a pipe enters and opens above the water surface into the cavity of a small gasometer, made of very light tinned sheet brass, and having an upper surface of exactly 100 square centimetres. The gasometer dips into the water, and is hung by a strong silk, which, after first having passed over a pulley connected by a wheel with an index-hand, has its other end fastened to a spring properly tempered. The open perpendicular tube is connected by means of a caoutchouc tube with the pipe which enters the anemometer. When the connections are thus made, it is evident

<sup>1</sup> *Quarterly Journal of the Royal Meteorological Society*, vol. v., p. 208. 1879.



that any change in rarefaction will turn the index-hand. A rarefaction of 1 millimetre water pressure will act as if a layer of 1 millimetre of water were laid on the whole surface of the gasometer; this on 100 square centimetres is a weight of 10 grammes. Hence, by loading the gasometer with 10, 20, 30, 40, up to 100 grammes, the position of the index will correspond to 1, 2, up to 10 millimetres suction, and the scale is divided accordingly. A scale for velocity of wind, in metres per second, is calculated by the formula  $V = 3.9 \times \sqrt{h}$  ( $h$  being the water pressure in millimetres), and is also marked. The velocity of the wind is, so to speak, weighed. Neither temperature, pressure, moisture, rain, snow, nor hail has any influence upon this anemometer, the action of which is regarded by the inventor as perfectly satisfactory. The Hagemann anemometers are manufactured by Nyrop of Copenhagen.

*H. Direction.*—Lomonosow (1751) attached to the vane-spindle of his anemometer a vertical wheel, with a tube containing mercury running round the greater part of its circumference—perhaps  $300^\circ$ . As this wheel, bridled by a spring, turned on its axis, a small quantity of the mercury was poured out into a tray beneath, divided into thirty-two radiating compartments; the compartment in which the mercury was afterwards found indicated the direction of the wind, the quantity of mercury its force. Beaudoux (1777) registered the direction only by fine sand falling into a similarly divided tray. Goddard (1844) used water in the same way. Craveri (1866?) adopted a similar method of registry, corn grains being the weight employed.

*I. Inclination.*—Various instruments have been designed with the object of showing whether any given current of wind has an upward or downward tendency. Benzenberg (1801) caused the windward end of the direction vane to carry a vertical fork open to the wind; across this was fixed the axis of a horizontal vane, which showed the inclination of the wind. Cacciatore (1840), Director of the Observatory at Palermo, caused the velocity of the wind to be given by a horizontal fan of four curved sails, which, being segments—apparently quadrants—of

a cylinder, necessarily revolved in one direction. A similar fan on a horizontal axis was fixed in a rectangular frame fastened to an upright spindle, so as always to swing away from the wind and rotate in a plane at right angles to the wind's direction. It could be acted on only by the vertical component of the wind. More modern instruments for observing the inclination are those invented by Professor Hennessy (1856) and Father Dechevrens

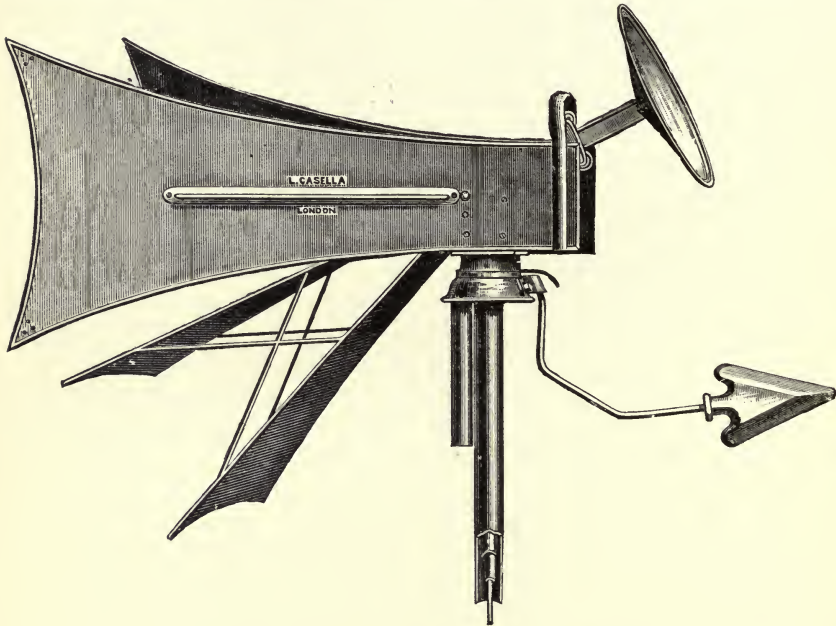

FIG. 79.—VANE OF CASELLA'S ALTAZIMUTH ANEMOMETER.

(1881), of the Observatory of Zi-Ka-Wei, near Shanghai (*Sur l'Inclinaison des Vents*).

In 1886, Mr. Louis Marino Casella, F.R.Met.Soc., described to the Royal Meteorological Society an altazimuth anemometer which he had designed and patented. The object of the instrument is to record continuously the vertical angle, as well as the horizontal direction and force, of the wind. A full description of his instrument will be found in the *Quarterly Journal of the Royal Meteorological Society*, vol. xii., No. 60, October, 1886,

p. 246. The existence of air currents moving in a direction more or less inclined to the plane of the horizon, or "*inclined currents*," as Mr. Casella calls them in his paper, being conceded, the necessity for the study of their inclination and velocity is at once apparent. Mr. Casella's anemometer, which includes in its construction the principle of the engineering instrument known as

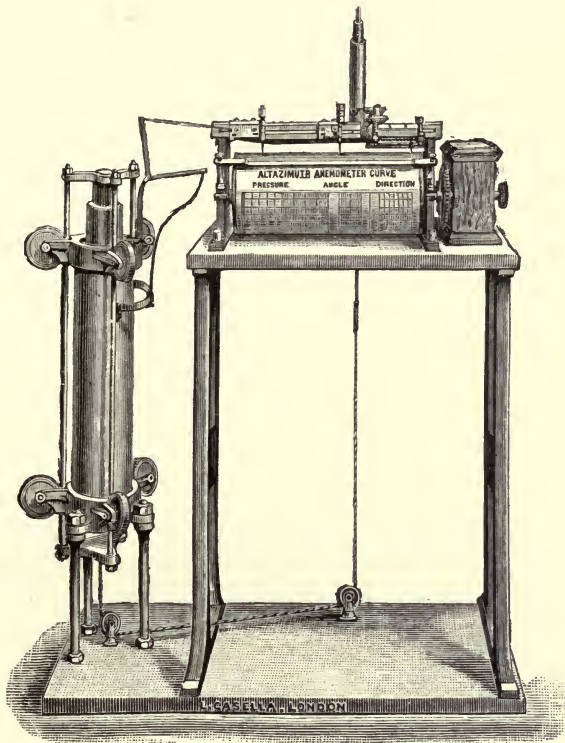

FIG. 80.—CASELLA'S ALTAZIMUTH ANEMOMETER.

the altazimuth, records continuously on one sheet of paper the pressure, direction, and inclination of the wind, with all its changes, the pressure plate being always maintained truly at a right angle to the wind. The apparatus for indicating the direction of the wind consists of a vane (Fig. 79), constructed of a pair of diverging blades fixed to a cap, mounted so as to

rotate about a vertical axis, the motion of this vane being transmitted by a vertical tubular shaft passing downwards through the usual fixed column to the registering mechanism. This tubular shaft, called the "direction tube," is made to operate the styles which record its movements through the medium of pinions and wheels, conveying motion to two discs, which are made to carry pencils in a vertical position and equidistant; three styles are used, so that one is always ready to enter on the scale at one side when another leaves it at the other side (Fig. 80).

The apparatus for indicating the inclination of the wind—that is, its divergence from a horizontal plane—consists of a similar vane (composed of a pair of diverging blades), mounted on a horizontal axis within the direction vane, so balanced as to assume normally, when no wind is blowing, a position in which its longitudinal axis is horizontal. To insure this, the vane is brought to a condition of stable equilibrium as closely approximating to that of instability as it is possible to bring it.

The oscillating motion of this inclination vane is transmitted to its registering mechanism by a tubular connecting rod, jointed to the vane by a pair of links, which move up and down inside the direction tube. The inclination tube is so connected with the carriage of a style. Thus its longitudinal motion affects only the latter, which thus records upon the scale the oscillations of the vane due to the varying inclination of the wind.

The pressure plate is a disc, having an area of  $1\frac{1}{2}$  square feet, fixed to a guide rod, fitted to slide between pairs of guide rollers in the frame of the inclination vane, and moving with it. This plate should have had a cone at the back, which was omitted in its construction. In order to prevent the varying positions of the pressure plate affecting the balance of the vane, its motion is constantly and exactly compensated by a movable weight running on rollers, so arranged that the weight moves to a proportionate extent in the opposite direction to the pressure plate, so as to maintain the balance of the vane in all positions of the pressure plate. The motion of the pressure plate is transmitted to the apparatus for measuring the force by means of a chain



attached to the guide rod of the plate, and passing down over a pulley through the tubular shaft of the inclination vane. To prevent the weight of this chain affecting the accuracy of the records, it is exactly balanced by a counterpoise hanging in a casing carried by the cap. In this way the pressure plate is kept perpendicular to the direction of the air current, not only in azimuth, but also in altitude.

The apparatus for measuring the pressure consists of a cistern containing mercury, and a displacement plunger immersed therein, connected to a frame of guide rods joined together above and below the mercury cistern, which works up and down against guide wheels mounted around the cistern, the chain being attached to the bottom of the frame. The plunger has a varying ratio of displacement for successive depths of immersion, so that the scale may be open for the smaller and compressed for the greater (and less frequent) pressures. In order to check the motion of the plunger and avoid inaccuracy in the indications, due to the momentum of the parts, the lower end of the plunger is provided with a disc, fitting more or less closely to the sides of the mercury cistern, so as to prevent the too rapid passage of the mercury from one side of the disc to the other.

The frame is connected to the carriage of the marker for registering the motions of the plunger by means of a bell-crank lever. The carriage carrying the recording pencil is mounted to travel upon rollers running upon the oppositely bevelled edges of a horizontal bar and rollers running on the front and back surfaces, by which it is truly guided with the least possible friction. The markers are all metallic, sliding in sockets and pressing by their own weight or by springs on the paper. The scales for the different records are marked upon a single sheet of paper wrapped round a cylinder, rotated at a uniform speed by a clock movement in the usual manner.

As a mere anemoscope, Mr. Laughton considers that none of these elaborate contrivances excels the simple little feather vane in daily use on board our men-of-war. It is a tapering tail, 8 inches long by  $1\frac{1}{2}$  inches wide where broadest, made of the softest down or feathers, and tied to the top of a staff by a

short thread. Let the wind blow how it will, this must stream with it.

J. *Musical Anemometers* have been suggested and designed by Hooke (1667), Athanasius Kircher, Leupold (1724), and Delamanon (1782). These instruments were so constructed as to emit musical sounds when the wind blew upon them. They were scientific toys at the best.

K. *The Helicoid Anemometer*.—In the *Quarterly Journal of the Royal Meteorological Society* (vol. xiii., p. 218, 1887), Mr.

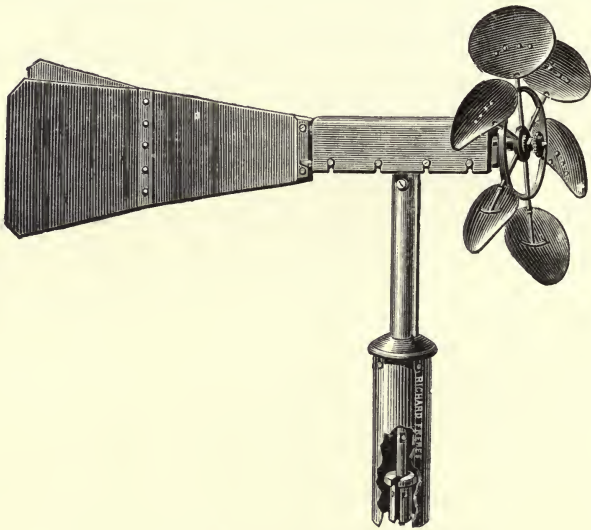

FIG. 51.—VANE OF RICHARD'S ANÉMO-CINÉMOGRAPHE.

W. H. Dines, B.A., F.R.Met.Soc., has a paper on a "New Form of Velocity Anemometer," which he read before the Society on April 20, 1887. In this instrument an attempt was made to measure the velocity of the wind by the rotation of a small pair of windmill sails, the pitch of the sails being altered automatically, so that their rate may always bear the same ratio to that of the wind. These sails present what is called a "helicoid" surface (Greek, ἑλιξ, a spiral; and εἶδος, resemblance), or one which may be rotated about its axis in a current of air (the

axis, of course, pointing in the direction of the current) without causing any deflection or whirl in the air passing over it.

L. *The Anémo-Cinémographe*.—On May 19, 1892, the late Mr. G. M. Whipple, B.Sc., Superintendent of the Kew Observatory, laid before the Royal Meteorological Society the results

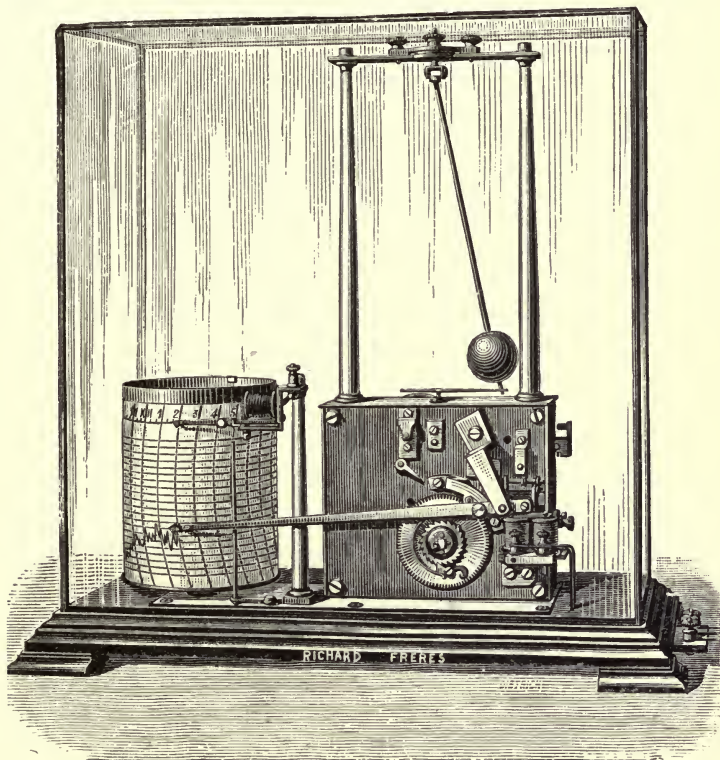

FIG. 82.—RICHARD'S ANÉMO-CINÉMOGRAPHE.

of a comparison of Richard's *Anémo-Cinémographe* with the standard Beckley Anemograph at the Kew Observatory.<sup>1</sup> This ingenious instrument (Figs. 81, 82, 83, and 84) is a modification of the old Whewell fan, or windmill vane, the change being in the shape of each blade of the vane, which is made oval and

<sup>1</sup> *Quarterly Journal of the Royal Meteorological Society*, vol. xviii., p. 257. 1892

fitted at an angle of  $45^\circ$  to the axis. The vanes are said by MM. Richard to have been carefully calibrated. The fan is formed by six little wings or vanes of sheet aluminium, 4 inches in diameter, inclined at  $45^\circ$ , riveted on very light steel arms, the diameter of which is so calculated that the vane should make exactly one turn for the passage of a metre of wind (Fig. 81). Its running is always verified by means of a whirling frame fitted up in an experimental room where the air is absolutely calm, and, if necessary, a table of corrections is supplied. The recording part of the apparatus is called the *Anémo-Cinémographe*,

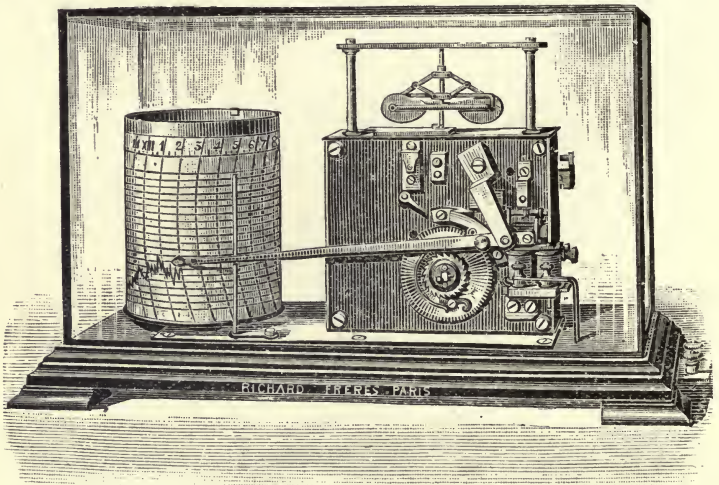

FIG. 83.—RICHARD'S ANÉMO-CINÉMOGRAPHE (Second Form).

and in principle is as follows: The pen, recording on a movable sheet of paper, is lowered at a constant rate by means of a conical pendulum acting through a train of wheel-work, whilst a second train, driven by the fan, is always tending to force it up from the lower edge of the paper. Its position is, therefore, governed by the relative difference in the velocity of the two trains of wheel-work, being at zero of the scale when the air is calm, but at other times it records the rate of the fan in metres per second (Fig. 82). Fig. 83 represents another pattern of the same instrument, which, however, does not record the direction of the wind,



MM. Richard having constructed another apparatus for that purpose.

Another pattern of the anémo-cinémographe (Fig. 84), with endless paper running  $1\frac{1}{4}$  inches a minute, has been made by MM. Richard for the Bureau Central Météorologique of France for studying the storms on the top of the Eiffel Tower in Paris.

Notwithstanding the recommendation of the Vienna Meteorological Congress (1873), Robinson's and Osler's anemometers still hold the field—in British observatories, at all events. A Robinson anemometer should be well exposed, its machinery should be kept well oiled, and the following particulars should always be furnished with a register of its indications: (1) Length of arm (axis to centre of cup); (2) diameter of cups; (3) how the registration is effected (mechanically, electrically, or otherwise); (4) name of maker; (5) height above the general surface of the ground (William Marriott).

The Munich International Meteorological Conference (1891) was of opinion that it is desirable to publish wind velocities in metres per second; and the International Meteorological Committee, at the Southport meeting in 1903, held that the height of the anemometer above the ground ought always to be given at the head of all published tables of wind velocities.

The *mean direction* of the wind may be calculated by the formula proposed by Lambert towards the close of the last century. It is given by Dr. Scott as follows:

$$\tan \phi = \frac{E. - W. + (N.E. + S.E. - S.W. - N.W.) \cos 45^\circ}{N. - S. + (N.E. + N.W. - S.E. - S.W.) \cos 45^\circ}.$$

In this equation  $\phi$  is the deviation of the mean direction from north round by east.

In 1889-90 Mr. W. H. Dines, B.A., F.R.Met.Soc., carried out a series of experiments on the resistance of plates of various forms at oblique incidences to the wind, and communicated the results to the Royal Society in a valuable paper.<sup>1</sup> Mr. Dines subsequently carried out a series of comparisons between specified anemometers at the request of the Council of the Royal Meteorological Society.

<sup>1</sup> "On Wind Pressure on an Inclined Surface," *Proceedings of the Royal Society*, vol. xlviii., pp. 233-257.

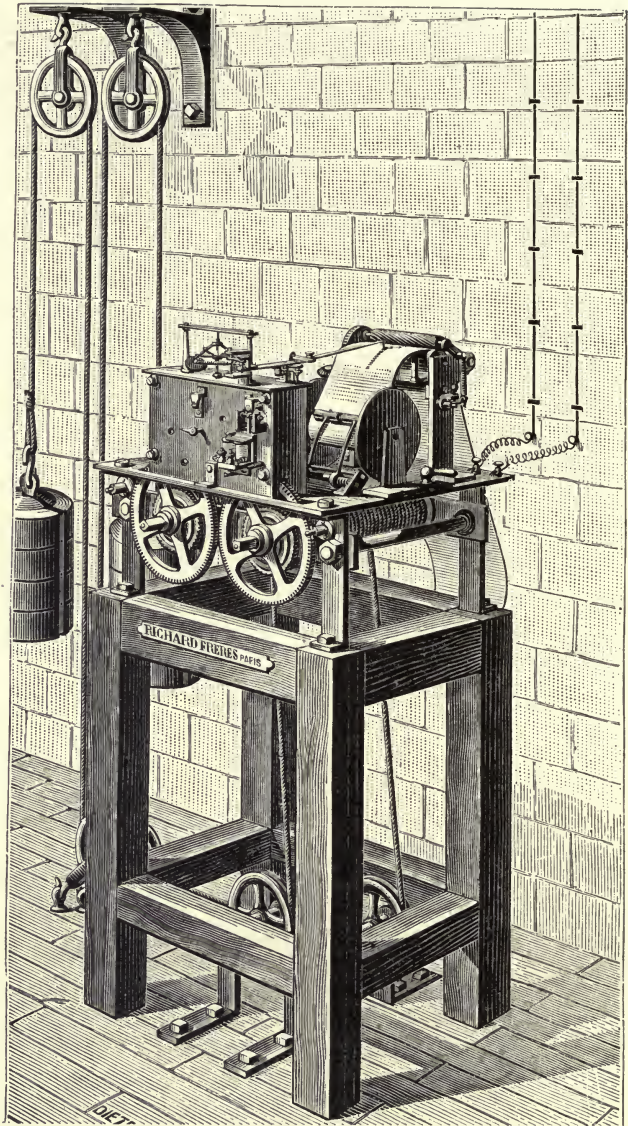

FIG. 84.—ANÉMO-CINÉMOGRAPHE IN POSITION.

logical Society, the cost being defrayed by the Meteorological Council. The instruments compared were :

- |                         |   |   |
|-------------------------|---|---|
| Velocity<br>Instruments | { | 1. Kew Pattern Robinson Anemometer.   |
|                         |   | 2. Self-adjusting Helicoid Anemometer (Dines). This instrument is described, as stated above, in the <i>Quarterly Journal of the Royal Meteorological Society</i> , vol. xiii., p. 218. 1887. |
|                         |   | 3. Small Air-Meter.   |
| Pressure<br>Instruments | { | 4. Foot Circular Pressure Rate.   |
|                         |   | 5. A special modification of the Tube Anemometer.   |

The conclusions arrived at are given in a note appended to the Report of the Meteorological Council to the Royal Society for the year ending March 31, 1892 (pp. 23, 24). They are to the effect that, with proper precautions, the tube anemometer—a combination of Lind's and Hagemann's instruments—will form a most useful and convenient instrument, that the relation between pressure and velocity for a foot circular plate, and at ordinary barometrical pressure, is  $P = \cdot 003 V^2$ , and that the factor of the Kew Pattern Robinson Anemometer is practically constant for all velocities except very low ones, that its value must lie between 2·20 and 2·00, and that there is a very great probability that it is within  $2\frac{1}{2}$  per cent. of 2·10.

Mr. Dines read his paper on "Anemometer Comparisons" before the Royal Meteorological Society on April 20, 1892. It is fully illustrated, and was published in the *Quarterly Journal* of the Society (vol. xviii., No. 83, July, 1892, p. 165).

At pages 269 and 270, illustrations are given of an enlarged anemometer or anemograph, constructed by Mr. L. Casella for harbours and public observatories. In this arrangement (Fig. 71) windmill fans are added to the wind vane, causing the mean direction of the wind to be accurately indicated by means of a revolving cylinder (Fig. 72) to which paper is attached. The direction as well as the velocity is continuously shown for every minute of time by means of a clock, which forms part of the instrument. The exposed part of this anemometer may be placed at any height, whilst the registering part is kept in a room or other covered place for observation.

The climate of the British Isles is essentially windy, or even stormy. Hence the following will prove of interest to the student of that climate.



In a paper read before the Royal Meteorological Society on June 20, 1894, Mr. R. H. Curtis stated that the greatest force of an individual gust which he had met with was registered in December, 1891, and amounted to a rate of 111 miles per hour, which, with the old factor, would be equivalent to a rate of about 160 miles per hour. Gusts at a rate of from 90 to 100 miles per hour have many times been recorded, but the usual limit for gusts may be taken to equal about 80 miles per hour, which on the old scale would be equivalent to about 120 miles per hour. Gales and strong winds differ much in character. There are gales which are essentially squally. In these the gusts constitute the main feature. In an average gale the ordinary gusts occur at intervals of about ten to twenty seconds; the extreme gusts at intervals of about a minute. Another class of gales show a tolerably steady wind velocity. In the third class are gales which appear to be made up of two series of rapidly succeeding squalls—the one series at a comparatively low rate of velocity, the other at a much higher one, the wind-force shifting rapidly and very frequently from one series to the other. Mr. Curtis has not infrequently found very distinctly marked in the anemometer tracings a prolonged pulsation in the wind-force, which recurs again and again with more or less regularity, sometimes every twenty minutes or half an hour, sometimes at longer intervals of about an hour or so.

Between sunset of February 26 and noon of February 27, 1903, the British Isles were swept by a storm of most unusual violence. A vast amount of damage was done to trees and buildings by gales from the south or south-west, particularly in the neighbourhood of Dublin, where very large numbers of trees were uprooted, and in Lancashire. This storm of almost hurricane force was the subject of an able paper by Dr. W. N. Shaw, D.Sc., F.R.S., Director of the Meteorological Office, with the assistance of Mr. R. G. K. Lempfert, M.A., and F. J. Brodie, F.R.Met.Soc. This paper was read before the Royal Meteorological Society on June 17, 1903.<sup>1</sup> The appended Table gives the wind velocities from anemograph records.

<sup>1</sup> *Quarterly Journal of the Royal Meteorological Society*, vol. xxix., No. 128, p. 233 : 1903 ; and *Monthly Weather Review*, vol. xxxi., p. 218 : 1903.



## STORM OF FEBRUARY 26-27, 1903 (WIND VELOCITIES FROM ANEMOGRAPH RECORDS).

Observatories.	Wind Direction.	Time of Occurrence.	Maximum Velocity Recorded.
Valentia ..	W.S.W.	Midnight, 26th, to 1 a.m., 27th	63 miles in the hour.
Falmouth ..	S. by W.	Midnight, 26th, to 1 a.m., 27th	37 " "
Armagh ..	S.S.E.	11.50 p.m., 26th to 3 a.m., 27th	88 miles per hour, in squalls.
Kingstown ..	W.S.W.	4 to 5 a.m., 27th	33 miles in the hour.
Holyhead ..	S.W.	5 to 6 a.m., 27th	66 " "
Southport ..	W.S.W.	6 to 7 a.m., 27th	52 " "
Stonyhurst ..	W.S.W.	5.55 a.m., 27th	65 " "
Glasgow ..	W.	6 to 7 a.m., 27th	87 miles per hour, in squalls.
Deerness ..	E.	Noon to 1 p.m., 27th	43 miles in the hour.
North Shields	S.W.	7 to 8 a.m., 27th	26 " "
Aberdeen ..	S.E.	3 to 4 a.m., 27th	36 " "
Kew ..	S.S.W.	3 to 4 a.m., 27th	70 " "
Oxford ..	S.S.W.	4.7 a.m., 27th	33 " "
Berkhamsted	S.	3 to 4 a.m., 27th	32 " "
		2 to 3 a.m., 27th	59 miles per hour, in squalls.
			34 miles in the hour.
			23 " "

But the main interest in this highly scientific study of a historic tempest centres in the attempt made—and not unsuccessfully—by Dr. Shaw to trace the actual paths of definite masses of air in a travelling storm. For ease of distinction he calls the actual path of the air a “trajectory,” reserving the use of the word “path” for the motion of the storm centre. Dr. Shaw arrives at the following conclusions :

1. The more central area of the storm circulation is fed from outside by winds passing to a region in front of the centre, with directions in the quadrant between the direction from which the storm comes and the direction at right angles thereto on the left facing the coming storm.

2. When the storm centre has passed, corresponding winds blow out from behind the centre with directions from the adjacent quadrant on the other side of the path.

3. The winds from the remaining quarters will be comparatively transient in any locality, as the changes in them take place with great rapidity. These winds are represented by the parts of the loops of the curves above the path of the centre.

4. No air is taken into the storm area from the "northern" side of the path.

5. There is a great convergence of winds behind the centre to points in the line of the "trough." This convergence is associated with corresponding divergence in front of the trough, and apparent crossing of the trajectories at the trough itself (Fig. 85).

Dr. Shaw adds that the convergence and divergence must have reference to upward and downward convection.

The whole subject of the surface trajectories of moving air is

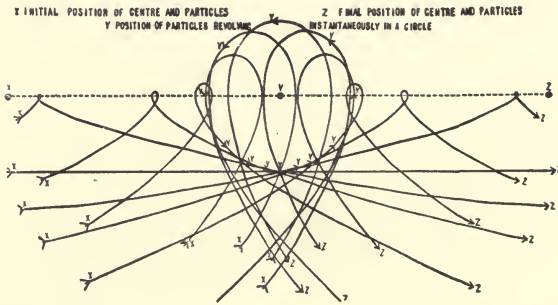

FIG. 85.—DIAGRAM OF LOOPED TRAJECTORIES FOR AN "IDEAL" STORM OF CIRCULAR ISOBARS AND UNIFORM WIND TANGENTIAL TO THE ISOBARS, TRAVELLING WITH THE SAME SPEED AS THE WIND.

discussed in detail by Dr. Shaw and Mr. R. G. K. Lempfert, M.A., in the *Life History of Surface Air Currents*, published by the authority of the Meteorological Committee in 1906 (M.O. 174). From that publication is taken this diagram of looped trajectories for an "ideal" storm of circular isobars and uniform wind tangential to the isobars, travelling with the same speed as the wind.

The curves are represented by the equation :

$$(a - y) (2a + y)^2 = 9 ax^2.$$

## CHAPTER XX

### ATMOSPHERIC ELECTRICITY

IN his Presidential Address to the British Association for the Advancement of Science, delivered at Winnipeg, Manitoba, in August, 1909, Professor Sir Joseph J. Thomson, M.A., LL.D., D.Sc., F.R.S., speaks of "the great ocean of the ether, the substance with which the whole universe is filled." He goes on to say: "The ether is not a fantastic creation of the speculative philosopher; it is as essential to us as the air we breathe. For we must remember that we on this earth are not living on our own resources; we are dependent from minute to minute upon what we are getting from the sun, and the gifts of the sun are conveyed to us by the ether. It is to the sun that we owe, not merely night and day, springtime and harvest, but it is the energy of the sun, stored up in coal, in waterfalls, in food, that practically does all the work of the world.

"How great is the supply the sun lavishes upon us becomes clear when we consider that the heat received by the earth under a high sun and a clear sky is equivalent, according to the measurements of Langley, to about 7,000 horse-power per acre. Though our engineers have not yet discovered how to utilise this enormous supply of power, they will, I have not the slightest doubt, ultimately succeed in doing so; and when coal is exhausted and our water-power inadequate, it may be that this is the source from which we shall derive the energy necessary for the world's work. When that comes about, our centres of industrial activity may perhaps be transferred to the burning deserts of the Sahara, and the value of land determined by its suitability for the reception of traps to catch sunbeams.

“ This energy, in the interval between its departure from the sun and its arrival at the earth, must be in the space between them. Thus this space must contain something which, like ordinary matter, can store up energy, which can carry at an enormous pace the energy associated with light and heat, and which can, in addition, exert the enormous stresses necessary to keep the earth circling round the sun and the moon round the earth.

“ The study of this all-pervading substance is perhaps the most fascinating and important duty of the physicist.

“ On the electro-magnetic theory of light, now universally accepted, the energy streaming to the earth travels through the ether in electric waves ; thus practically the whole of the energy at our disposal has at one time or another been electrical energy. The ether must, then, be the seat of electrical and magnetic forces.”

It is to the operation of these forces that the phenomena of atmospheric electricity and of the aurora are due.

The identity of atmospheric electricity with that obtained from an electrical machine, foreshadowed by Dr. Wall in 1708, was finally proved by Benjamin Franklin in June, 1752. His classical experiment of obtaining electricity from the clouds by flying a kite need not be referred to in detail. In a letter to Mr. Peter Collinson, F.R.S., dated Philadelphia, October, 1752, Franklin describes his electric kite.<sup>1</sup> Suffice it to say that the experiment is a dangerous one. In June, 1753, M. de Romas in France repeated it, using a fine wire 550 feet long instead of a string, with the result that he obtained flashes 9 or 10 feet in length, which were accompanied by a loud report. On one occasion De Romas was struck down, but not killed, by such a charge. In August of the same year, Professor Richmann, of St. Petersburg, lost his life during a thunderstorm. He approached the end of the conducting wire, when a ball of fire apparently leaped to his head, killing him on the spot.

Lemonnier proved, by means of insulated metal rods, that the atmosphere is charged with electricity even in fine weather. Volta and de Saussure, subsequently, each constructed an instru-

<sup>1</sup> *Philosophical Transactions*, vol. xcvi., p. 565. 1752.



ment, called an *electroscope*, for collecting atmospheric electricity and demonstrating its effects. In de Saussure's electroscope the electricity conducted from a rod to two little pith balls suspended by fine wires in a glass case caused them to diverge from one another. Alessandro Volta of Pavia substituted two blades of straw an inch long for the pith balls. The most delicate of all electroscopes is that which is called the "gold-leaf electroscope."

Before, however, I attempt to describe the chief electrical phenomena in nature, it will be desirable to draw attention to certain rudimentary facts relating to the nature of electricity. These are admirably summarised in the following sentences taken from an address on "Atmospheric Electricity," delivered before the Royal Meteorological Society on March 21, 1888, by the late Dr. W. Marcet, F.R.S., then President of the Society.<sup>1</sup>

"Like *heat*," says Dr. Marcet, "electricity is the manifestation of a peculiar condition of a body, and bodies are said to be *electrified* when, after having been rubbed, or placed in communication with an electrified object, they exercise an attraction or repulsion, more or less great, upon other light bodies. On inquiring into this phenomenon, it is found that the *electricity* developed by friction from different substances such as *glass* on the one hand, and *sealing-wax* on the other, is not identical, and that there are consequently two electricities, varying from each other in some of their characters. It may be said in a general way—

"1. That there is an attraction between an electrified body and another not electrified.

"2. That there is an attraction between two bodies electrified, the one by a rubbed glass rod, the other by a rubbed stick of sealing-wax, or of some resinous substance.

"3. That there is a repulsion between two bodies, both of which are electrified either by glass or by sealing-wax.

"To put these laws of Nature more clearly, electricities of different kinds attract each other, and electricities of the same kind repel each other.

"In order to distinguish between the two kinds of electricity, the one is called *vitreous* electricity, from its being generated from

<sup>1</sup> *Quarterly Journal of the Royal Meteorological Society*, vol. xiv., p. 197, 1888.

glass, and is known as *positive*, while the other is called *resinous* electricity, and is known as *negative*."

Atmospheric electricity may, from time to time, reveal its presence by very unequivocal phenomena, of which the chief are (1) thunder and lightning, (2) hailstones, (3) aurora—the aurora borealis being peculiar to the northern hemisphere, the aurora australis to the southern. The aurora is an electrical phenomenon of cosmical origin. It is usually associated with magnetic storms, and usually appears as a bright arch beneath which the sky looks darker than in the surrounding regions. Frequently streamers of white or rose coloured light shoot out in long rays from the arch towards the zenith. Sometimes the arch resembles a swaying sheet or curtain of light, or, again, several arches may be seen simultaneously.

But apart from these manifestations, observations should be made upon the electricity existing in the air under ordinary circumstances, so as to determine, firstly, whether it is positive or negative; secondly, what is its intensity or tension.

In a Report on Atmospheric Electricity, drawn up at the request of the Permanent Committee of the First International Meteorological Congress at Vienna, and published by the Meteorological Council in 1878, Professor J. D. Everett, M.A., Queen's College, Belfast, observes that in discussions relating to the electrical condition of the air at a specified point three things must be carefully distinguished: electrical density, electrical force, and electrical potential.

(a) The electrical *density* at a point in the air is the quantity of electricity, per unit volume, with which the air at the point is charged.

(b) The electrical *force* at a point is the force with which a unit of positive electricity would be acted on, if brought to the point without altering, by its inductive action, the previously existing distribution.

(c) The electrical *potential* at a point is the work which would be done by electrical force upon a unit of positive electricity passing from the point to the earth, the movement of this unit being supposed not to disturb the pre-existing distribution.

In Dr. R. H. Scott's *Instructions in the Use of Meteorological*

*Instruments*<sup>1</sup> concise information as to the apparatus used in researches on atmospheric electricity will be found. From that source chiefly the following is culled :

1. The *electroscope* is intended to show the *nature* or *kind* of electricity present in the air. By far the most sensitive instrument for this purpose is the gold-leaf electroscope (Fig. 86), in which electricity collected from the neighbouring atmosphere is made to act through a metal rod, called a conductor, upon two delicate gold leaves suspended at the end of the rod, and applied closely to each other. The leaves, when brought under the influence of the same kind of electricity, will diverge or repel each other. As very little electricity can be observed near the ground, the conductor should be placed in contact with the air at some height above the earth's surface, by means of a—

2. *Collector*.—This may be a metallic arrow tied to one end of a conducting string, and then shot upwards into the air. The electroscope will be found elec-

trified as the arrow mounts. A gilded fishing-rod may be substituted as a conductor, its lower end being *insulated*—that is, surrounded by a non-conductor such as caoutchouc.

Volta's collector is a flame burning at a height, either in a lantern hung to a mast and connected with the electroscope by a wire, or in the form of a slow-burning match attached to the top of a long metal rod. The electricity of the air, in the neighbourhood of the flame, by its inductive action on the conductor, causes

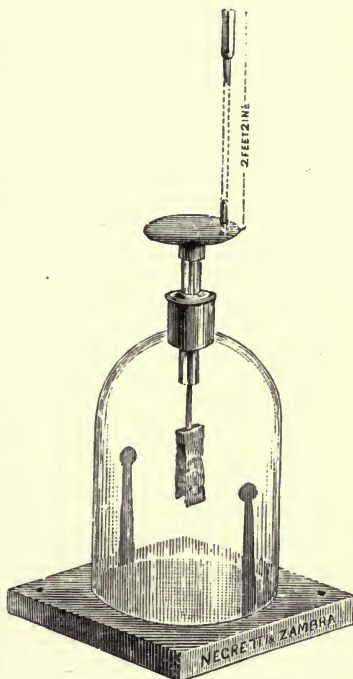

FIG. 86.—GOLD-LEAF ELECTROSCOPE.

<sup>1</sup> Reprinted, p. 60 *et seq.*, 1885. London : E. Stanford.

electricity of the opposite kind to accumulate at the upper extremity, whence it is constantly carried off by the convection currents in the flame, leaving the conductor charged with electricity of the same kind and potential as the air.

It is necessary again to explain that the term *potential*, as applied to electricity, means the energy of an electrical charge measured by its power to do work ; it is electro-motive force. " When one body is charged with electricity to a higher potential than another, electricity tends to pass off, so as to equalise the potential on the two bodies " (R. H. Scott).

Dr. Scott says that " when we speak of the motion of the electricity from one body to another, we say that this is effected owing to difference of potential." He adds : " Difference of electric potentials may very well be termed ' difference of electric heights.' "

The water-dropping collector, invented by Sir William Thomson, afterwards Lord Kelvin, Professor of Natural Philosophy in the University of Glasgow, who died in 1907, is on the same principle as Volta's method. A copper can is placed on an insulating support, either of ebonite, with its surface thinly coated with paraffin, or of glass surrounded with pumice-stone impregnated with sulphuric acid. From the can a small pipe projects far into the air, and terminates in a fine jet. The can being filled with water, and the tap which opens into the jet being turned on, a small stream of water is allowed to flow out *guttatim*, in drops. In half a minute the can is found to be electrified to the same extent and in the same way as the air at the point of the tube.

This collector cannot be employed in frost, for the water freezes in the jet. At such times the use of a slow-burning match, made of blotting-paper, steeped in a solution of nitrate of lead, dried and rolled, was recommended by Lord Kelvin.

Since electrical density is greater on projecting surfaces and less on hollow surfaces than on planes, the collector should not be near trees, or houses, or within a closed space.

3. *Electrometer*.—This is an instrument which is intended to measure the *amount* of electricity, or the electric intensity, tension, or potential. The earliest electrometer was Coulomb's



Torsion Balance, by means of which one of the principal laws of electricity was discovered—that two electrified bodies, whose size is very small in comparison with their distance apart, attract or repel each other with a force proportional to the inverse square of the distance which separates them. Lord Kelvin designed two kinds of electrometer—(1) the Quadrant Electrometer for observatory use; (2) the Portable Electrometer.

In the Quadrant, or modified Divided-Ring, Electrometer, a needle of thin sheet aluminium, cut so as to resemble in form a figure "8" with the hollows filled in, and carrying above it a small light mirror weighing only a fraction of a grain, is suspended from its centre by two fine silk threads, the distance between which can be varied at will. The needle swings horizontally inside a shallow cylindrical brass box, which is cut into four equal segments or quadrants, each insulated separately by glass supports, but connected alternately by thin wires. Each pair of quadrants is also connected to a stiff wire passing through the case of the instruments, to form the two electrodes, or terminals, for the attachment of the collecting and earth wires.

The base of the electrometer contains a Leyden jar, partially filled with strong sulphuric acid, and a platinum wire, hung from the lower surface of the needle, is made to dip into the acid.

A lamp and a divided scale are placed about a yard in front of the instrument, and the light shining through an aperture in the frame of the scale is reflected by the mirror on the scale, where the position of the image of a wire stretched across the hole can be accurately observed.

In order to make use of this electrometer the needle must be charged with electricity from a small electrophorus or electricity-bearer, brought into contact with a wire (charging electrode) dipping into the sulphuric acid at the bottom of the Leyden jar. One of the electrodes connected with the segments is then joined by a wire to the water-dropping collector; the other is placed in communication with the earth through a wire attached to a gas-pipe, or similar conductor. The needle will then be deflected towards either one side or the other, according as the electricity of the atmosphere is of the nature to repel or attract it, and the extent of repulsion, as measured on the scale, is proportional to

the amount of difference of potential between the atmospheric and terrestrial electricities.

To secure that the needle shall remain fully charged, an auxiliary apparatus for the generation of electricity, termed a *replenisher*, is fixed inside the case, by turning which the charge can be restored to its original potential. This is indicated by a small gauge consisting of a light lever, made of thin aluminium, and fixed to the top of the instrument. One end of this gauge carries an index which moves in front of a small scale. The other end is flattened into a plate of about a square centimetre in area, which is repelled by another plate, similarly electrified, fixed to the top of the instrument, and in metallic connection with the sulphuric acid of the Leyden jar, so as to be charged to the same potential as the indicating needle. The position of the index being therefore once determined, it is easy, by giving a few turns to the replenisher, at least once daily, to bring the potential of the charge of the instrument up to its original value.

The scale value of each electrometer must be experimentally determined by means of a galvanic battery of constant intensity such as Daniell's. Knowing the electro-motive force of the cell employed in the battery, the indications of the electrometer scale may be converted into terms of the absolute unit of electro-motive force or "volts."

If the electrometer is used as a self-recording instrument, a drum carrying photographic paper, and maintained in rotation at a uniform rate by a chain of clockwork, is substituted for the divided scale, and the aperture is reduced so as to form a mere dot of light on the cylinder.

Thomson's quadrant electrometer was used, in conjunction with a water-dropping collector, for photographically recording atmospheric electricity at the Kew Observatory from 1874 to 1885. It has been in use at the Royal Observatory, Greenwich, since 1877. The instrument was described, with illustrations, in the *British Association Report* for 1867, p. 489.

In Lord Kelvin's Portable Electrometer (Fig. 87) the electricity is collected by means of a burning fuse at the extremity of a vertical wire. An illustrated description of it is given in the *British Association Report* for 1867, p. 501.

Another electrometer which is highly recommended is Peltier's. It was used for more than thirty years by the late M. Quetelet at Brussels, and for upwards of twenty years at Utrecht. This electrometer is described in the *Annuaire Météorologique de France*, 1850, p. 181, and in the *British Association Report*, 1849 ("Transactions of Sections," p. 11).

Quetelet, according to Dr. R. H. Scott, drew the following conclusions from five years' observations with the electrometer at Brussels :

1. The diurnal march of electricity, at a constant height above the ground, exhibits two maxima and two minima.

2. The maxima and minima of electrical tension precede by about an hour those of barometric pressure (see Chapter XIII., p. 151 above). The maxima occur when temperature is either rising or falling most rapidly—8 a.m. and 9 p.m. in summer, 10 a.m. and 6 p.m. in winter. The day minimum corresponds with the period of maximal temperature and minimal humidity. The epoch of the night minimum has not been satisfactorily determined, but was referred by de Saussure and Schübler to shortly before daybreak.

3. The annual march of electricity presents one maximum in summer (June) and one minimum in winter (January).

In nature the atmosphere, whether clear or cloudy, always shows an electric reaction—it is in a state of electric tension, which increases remarkably with altitude, as has been observed by de Saussure, Erman, Quetelet, Lord Kelvin, and the Hon. Ralph Abercromby (by the last named on the Peak of Teneriffe in July and August, 1878). Lord Kelvin found in the island of Arran, at a height of 9 feet above the ground, a difference of

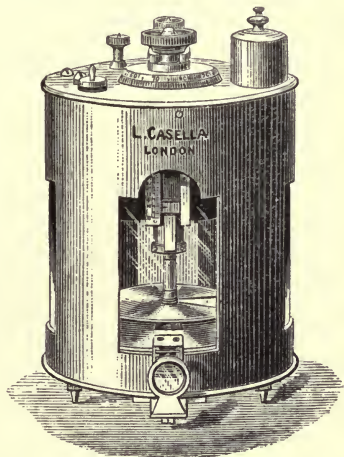

FIG. 87.—THOMSON'S PORTABLE ELECTROMETER.

potential equal to 200 to 400 Daniell cells, or from 216 to 432 "volts"—a volt being the standard of electro-motive force, or "potential," on the C.G.S. system of fundamental units of mass, length, and time (namely, centimetre, gramme, and second). This difference of potential, or *electric pressure*, represents a rise of potential of from 24 to 48 volts for each foot of ascent. This is subject to great variations. With north and north-east winds the potential was often six to ten times as much as the higher of the amounts just given. The change of potential is most rapid in cold, dry weather, when the quantity of moisture in the air is at its lowest.<sup>1</sup>

Under a clear sky atmospheric electricity is nearly always *positive*. According to Peltier, land is always *negative* in its electrical character, while Becquerel observed that sea-water is always *positive*. M. de la Rive holds that the positive electricity of the air is derived mainly from the sea. Clouds are in general electrified, positively as a rule, but sometimes negatively. Negative clouds are supposed to result from ground fogs charged with negative electricity, which they retain as they rise into the atmosphere. Or they may become negatively electrified by induction from superimposed positive clouds. In these facts we gain a clue to the origin of thunderstorms and other atmospheric phenomena of an electric character.

Professor Henry Mohn, Director of the Norske Meteorologiske Institut, Christiania, has classified thunderstorms into two groups—*Heat Thunderstorms* and *Cyclonic Thunderstorms*. The former type belongs to summer and to hot climates; the latter to winter and to insular climates.

*Cyclonic Thunderstorms* are so called because they accompany deep atmospheric depressions such as traverse the North Atlantic Ocean and the north-western seaboard of Europe, especially in winter. Scarcely a gale of wind of any extreme intensity occurs without attendant electrical phenomena. Occasional flashes of sheet-lightning light up the sky over wide areas during the passage of a winter storm, and here and there sharp hail and sleet squalls, with a few vivid flashes and loud peals of thunder, are experienced.

<sup>1</sup> *Ganot's Physics*, p. 1075. By Atkinson and Reinold. Sixteenth edition, 1902.



While these cyclonic thunderstorms are not so violent, they are quite as dangerous as summer thunderstorms, if not more so, because in them the clouds drift at a lower level, so that the lightning is more likely to strike the ground.

*Heat Thunderstorms* are especially associated with sudden and extreme alterations in atmospheric temperature. Perhaps a cool night has been followed by a blazing sun and a light south or south-east wind. Vast quantities of aqueous vapour rise in the atmosphere as the result of rapid evaporation. Massive cumuli form, the upper edges of which become more and more dense, and appear snowy white as the sun shines upon them. These clouds are probably surcharged with positive electricity. Then a light surface current of air arises and blows *towards* the approaching cumuli, while an angry-looking, lurid cloud stratum, negatively electrified, forms in the lower strata of the air, and is seen constantly to change its shape and density. Presently the top of the piled-up cumuli spreads out into a dense cirriform sheet, and at once thunder is heard, and rain or hail begins to fall in great quantities. With flash after flash, peal upon peal, the storm momentarily gathers strength and increases in violence. The hail and rain fall intermittently in drenching showers, and the whole sky becomes overcast, while the wind either falls light, dies down to a calm, or shifts perhaps to the opposite point of the compass in a fierce squall. The rain then lightens, the thunder and lightning become less frequent and more distant, and gradually the sky clears and the air feels cool and fresh—temperature perhaps being  $10^{\circ}$ ,  $15^{\circ}$ , or even  $20^{\circ}$  lower than before the storm.

From a careful analysis of the thunderstorms of 1888 and 1889 over the south and east of England, undertaken at the instance of the Council of the Royal Meteorological Society, Mr. William Marriott, F.R.Met.Soc., arrives at the conclusion that thunderstorm formations are small atmospheric whirls—in all respects like ordinary cyclones. The whirl, which is most probably confined to a stratum of air at only a short distance from the earth's surface, not more than 4,000 to 6,000 feet, may vary from one mile to ten miles or more in diameter. Thunderstorms usually occur when the isobars show large areas of ill-defined low pressure containing several shallow minima, called "thunderstorm de-

pressions," or when there is a "lane" or "trough" of low pressure between adjoining areas of relatively high pressure. Mist and fog often precede thunderstorms, which may accompany high barometer readings as well as low. On May 21, 1888, there was a thunderstorm with the barometer at 30.40 inches. On March 26, 1888, there was one with pressure below 29.00 inches. When isobars are drawn for hundredths, instead of tenths, of an inch, a number of small but distinct areas of low pressure, or cyclones, with regular wind circulation, may generally be recognised in thundery weather. In nearly all cases a sudden upward movement of the barometer is noticed when a thunderstorm breaks out. This increase of atmospheric pressure is usually well shown on barographic tracings.

These "thunderstorm depressions" often circulate round a large but shallow area of low barometer, forming secondary or subsidiary depressions to it as a primary. At other times they travel perhaps for hundreds of miles along a direct line, the rate of progression being sometimes as much as fifty miles an hour. On May 18-19, 1888, a storm passed across England from Christchurch, Hants (8.15 p.m.), to Edinburgh (4 a.m.) and Cupar-Fife (4.5 a.m.). Similarly, on June 2, 1889, a storm travelled northwards from Wiltshire (3 a.m.) to Edinburgh (10.44 a.m.), and probably to Kirkwall, in the Orkneys (3.37 p.m.), a distance of 550 miles, at a uniform rate of 50 miles an hour.

Thunderstorms often break out over the same line of country on consecutive days, and nothing is more curious than to watch thunder-clouds springing into existence in the sky time after time above a particular place or district, as if there was a direct electrical attraction for the time being between the earth just there and the superincumbent atmosphere, and this no doubt is in reality the case.

Heat thunderstorms show a diurnal and an annual periodicity. In tropical climates their periodicity is best marked. According to Arago, Jamaica is peculiarly liable to thunderstorms. From November to April the day breaks cloudless, but between 11 a.m. and 1 p.m. the mountains of Port Royal become covered with towering thunder-clouds. At the last-named hour rain falls in torrents, lightning flashes in all directions, and the crash of

thunder is incessant and deafening. But the storm is quickly spent, and a brilliant evening follows. It is an old observation of Caldcleugh<sup>1</sup> that at Rio Janeiro it was customary to state in invitations whether the guests were to assemble before or after the thunderstorm, which was practically a daily episode.

Europe presents examples of both types of thunderstorms. On the Continent and in England heat thunderstorms are prevalent in the summer months, the result being that the rainfall of July and August is particularly heavy, if not excessive. In Ireland, Scotland, and Norway heat thunderstorms are less frequent, while cyclonic thunderstorms are apt to occur, especially in the south-east quadrant of deep winter depressions. In Iceland thunderstorms are almost unknown in summer, whereas they frequently occur in winter. Dr. Alexander Buchan, in papers contributed to the Scottish Meteorological Society on the "Meteorology of Iceland"<sup>2</sup> and on the "Rainfall of Scotland,"<sup>3</sup> stated that during the twenty-five years 1846-1870 thirty-one thunderstorms occurred at Stykkisholm, Iceland, in January, seventeen in February, eight in March, six in April, two in May, none in June, two in July, none in August, five in September, five in October, fourteen in November, and twenty-five in December. In the second of the two papers mentioned, Dr. Buchan shows that the thunderstorms of the north-west of Scotland belong to the cyclonic type, while those of the south-east are heat thunderstorms for the most part.

England is celebrated for its thunderstorms in summer. They are far more severe and far more frequent than those felt in Ireland. This is due to the fact that the southerly winds in front of the depressions, which the thunderstorms accompany, have crossed the sea in the case of Ireland, but land—that is, France—in the case of England. The contrast of temperature between the south wind in front and the north wind behind the centre or trough of low pressure is, therefore, much greater for England than it is for Ireland. Again, the heated air rising over France is negatively electrified, while the warm sea air in Ireland is

<sup>1</sup> Quoted by Daniell in his *Meteorological Essays and Observations*. First Edition, p. 335. 1823.

<sup>2</sup> *Journal of the Scottish Meteorological Society*. New Series, vol. ii., p. 289. 1863.

<sup>3</sup> *Loc. cit.*, vol. iii., p. 251. 1873.

positively electrified. There is, then, attraction between the negative electricity of the ascending current and the positive electricity of the atmosphere over England, whereas over Ireland both the atmosphere and the ascending current of warm moist air are positively electrified. Hence there is no attraction, and no electrical energy is evoked. At the same time, it is true that negative electricity forecasts rain, of which there is no lack in Ireland. On the other hand, as Dr. Scott points out, a sudden development of positive electricity in wet weather is a certain sign of the sky clearing.

*Electrical State of the Upper Atmosphere.*—An investigation into this subject has been recently made at the Howard Estate Observatory, Glossop, Derbyshire, by the observers, W. Makower, Margaret White, and E. Marsden. The observatory stands at a height of 335 metres (1,099 feet) above mean sea-level. The results of a large series of experiments were communicated to the Royal Meteorological Society by Mr. J. E. Petavel, F.R.S., F.R.Met.Soc., on November 18, 1908.<sup>1</sup> As is well known, there exists under normal atmospheric conditions a potential gradient in the atmosphere surrounding the earth. The earth being negatively charged with respect to the air, a continuous electric current flows from the upper atmosphere to the earth's surface. The magnitude of this current has been estimated at  $2.2 \times 10^{-16}$  ampères per cubic centimetre of the ground by Mr. C. T. R. Wilson, F.R.S.,<sup>2</sup> and at  $2.4 \times 10^{-16}$  ampères per cubic centimetre of the ground by H. Gerdien.<sup>3</sup> An *ampère*, or the unit of current, is the current due to an electro-motive force of 1 volt working through a resistance of 1 *ohm*—the unit of resistance. A kite attached to an earth-connected wire will tend to assume the potential of the air surrounding it, and an electric current will flow continuously down the wire to earth through the winding machine with which the wire is connected. The experiments at Glossop were undertaken with the view of determining the magnitude of this current when the kite was at different heights above the ground.

<sup>1</sup> *Quarterly Journal of the Royal Meteorological Society*, vol. xxxv., No. 149, p. 7. January, 1909.

<sup>2</sup> *Proceedings of the Royal Society*, vol. lxxx., p. 537.

<sup>3</sup> *Physikalische Zeitschrift*, vol. vi. 1905.



The authors illustrate their communication with a series of figures showing the strength of the electric current at various specified heights expressed in ampères  $\times 10^{-5}$ . At heights exceeding 3,000 feet the currents were so large that it was found necessary to shunt the galvanometer with low resistances in order to get readable deflections. In general a high value of the current corresponded with a high velocity of the wind, a low value of the current with a low wind-velocity. The wind therefore is an important (though not the only) factor in causing large fluctuations from day to day in the strength of the electric current flowing to earth.

## CHAPTER XXI

### ATMOSPHERIC ELECTRICITY (*continued*)

*LIGHTNING*, according to Professor Balfour Stewart, owes its brilliancy to the generation of heat along the path of the electric discharge so intense as to render the various constituents of the air momentarily incandescent. This generation of heat is due to the resistance of non-conductors in the air to the discharge which takes place when clouds charged with different electricities approach each other.

*Thunder* is the noise, or atmospheric vibrations, produced in the first place by the tremendous expansion due to the heat of the lightning flash, and then by an inrush of air to fill up the vacuum so caused. Its prolonged reverberations are merely an acoustic phenomenon—an echo on a stupendous scale. When thunder is heard close at hand, it sounds first like a volley of musketry, because a separate report accompanies each zigzag movement on the part of the flash which is pursuing its uneven, if rapid, paths through masses of air of different conducting powers—moist air being a better conductor than dry air. As sound travels infinitely less quickly than light, a flash which is a mile away will be seen about five seconds before the thunder is heard.

Lightning may be described as of three kinds: (1) *Zigzag* or *forked* lightning; (2) *diffused*, *summer*, or *sheet* lightning; (3) *globular* or *ball* lightning.

Forked lightning does not occur in nature as drawn by artists. We know this, thanks to Mr. James Nasmyth's observations, communicated to the British Association in 1856. His statements have been amply confirmed by sixty photographic reproductions of lightning flashes, received by the Thunderstorm Committee of the Royal Meteorological Society in 1888, in reply

to a circular sent out in June, 1887. The first report of that Committee, drawn up by the Hon. Ralph Abercromby, F.R.Met.Soc., goes to show that lightning assumes certain



[F. Holmes, Mere, Wilts.

FIG. 88.—THUNDERSTORM AT MERE, MAY 13, 1906. PHOTOGRAPH TAKEN 9.40 P.M.  
(Reproduced by permission.)

Photo, Copyright]

typical forms—(1) Stream lightning ; (2) luminous lightning ; (3) ramified lightning ; (4) meandering lightning ; (5) beaded or chapped lightning ; (6) ribbon lightning.

Flashes of forked lightning take place horizontally or vertically between oppositely electrified clouds; or vertically between the negative earth and a positive cloud. The latter is very dangerous. And even when a living object is not in the direct path of the discharge, and so killed by the effect of the electricity on the nervous centres or muscular system, death may ensue by induction from what is called the "return shock." Suppose two clouds of opposite electricities are hovering over the earth at no great elevation. They will induce opposite electricities to their own in objects on the ground beneath them. A discharge now takes place between the clouds, establishing electrical equilibrium so far as they are concerned. When this takes place, the induced electricity in objects on the ground disappears, causing such a nervous shock to living beings as to deprive them of life. When a telephone gong sounds during a thunderstorm, it indicates that a return shock is taking place. Fig. 88 shows a remarkable flash of forked lightning with secondary streams, which was cleverly photographed by Mr. F. Holmes, Castle Hill Studio, Mere, Wiltshire, at 9.40 p.m. of Sunday, May 13, 1906.

Summer or sheet lightning (German, *Wetterleuchten*) is the diffused flash of light which illuminates the horizon or the distant clouds when a thunderstorm is raging at a great distance from the observer, perhaps 100 or even 150 miles away—far beyond the limits (15, or at the most 20, miles) at which thunder is audible.

Globular or ball lightning—"fire-balls"—is more persistent than forked lightning, remaining visible for several seconds, or even as long as *three minutes*, as happened at Milan in 1841 (Arago). It shows itself as a luminous sphere or ball of fire, in diameter varying from a few inches to 2 or 3 feet, which moves slowly, and at last bursts with a loud report like a bomb-shell. Dr. Scott, in his *Elementary Meteorology*, adduces several instances of this rare form of lightning.

The destructive effects of lightning are twofold, mechanical and combustible. If a flash of lightning strikes a sandy soil, it fuses or vitrifies the silicious particles into a *fulminary tube* or *fulgurite* (Latin, *fulgur*, *flashing lightning*). The German term is very expressive—*Blitzröhren*, *lightning tubes*. As a matter of fact, there is no such thing as a *thunderbolt*. In a paper on



“The Non-existence of Thunderbolts,” contributed by Mr. G. J. Symons, F.R.S., to the Royal Meteorological Society, on March 21, 1888,<sup>1</sup> the author effectually disposes of this myth.

Investigations made by Dr. Carl Müller, and reported in *Himmel und Erde*, show that lightning prefers to strike certain kinds of trees. Under the direction of the Lippe-Detmold Department of Forestry, statistics were gathered showing that in eleven years lightning struck fifty-six oaks, three or four pines, twenty firs, but not a single beech-tree, although seven-tenths of the trees were beech. It would seem, then, that in a thunderstorm one is safer under a beech-tree than under any other kind of tree.<sup>2</sup> The *Electrical Review*, August 10, 1906, however, reports that, while six men were sheltering under a beech-tree in the English Midlands during a severe storm a few days previously, two were killed and the others were struck down insensible. At the inquest, the Coroner said he had specially examined the tree, as for years he had read and understood that there was no record of a beech-tree being struck by lightning. In this case the lightning had not injured the tree to the extent of damaging a leaf. The accident was probably due to the “return shock.”

The lightning flash moves with inconceivable velocity. Sir Charles Wheatstone, by means of a rapidly revolving mirror, showed that the duration of a spark,  $\frac{1}{24000}$  inch in length, in air at ordinary atmospheric pressure was about  $\frac{1}{24000}$  second. He also ascertained that its velocity along the insulated wire with which he experimented was nearly 290,000 miles in a second—that is, half as great again as the velocity of light, 186,000 miles in a second.

Dr. R. H. Scott acknowledges, in his *Elementary Meteorology*,<sup>3</sup> his indebtedness to M. de la Rue for the following calculation of the potential, or electric pressure, necessary to produce a flash of lightning a mile in length. By his and Dr. Müller’s experiments (*Philosophical Transactions*, vol. clxix., p. 118) with his magnificent battery, the striking distance, between points, when 11,000 cells were used, the potential of each being 1.06 “volts,”

<sup>1</sup> *Quarterly Journal of the Royal Meteorological Society*, vol. xiv., p. 208. 1888.

<sup>2</sup> *Symons’s Meteorological Magazine*, vol. xxxi., p. 74. 1896.

<sup>3</sup> P. 180.

was .62 inch. This striking distance varies with the square of the number of cells employed. Then, as 1 mile = 63,360 inches, we have  $\sqrt{\frac{63,360}{.62}} \times 11,000 = 3,516,480$  cells, as the amount requisite to produce such a flash.

*St. Elmo's Fire*—a luminous electrical display—is the *Castor and Pollux* of the ancients. It is an induction phenomenon, and occurs when an electrified cloud approaches a prominent or pointed obstacle like the mast of a vessel, a flagstaff, a tree-top, or a lightning-conductor. The electricity of the cloud and of the earth combine, not in a flash of lightning, but more slowly and continuously, so that a flame seems to rise from the projecting point. Cæsar noticed it after a hailstorm, and described it in the words: "Eâdem nocte legionis quintæ cacumina suâ sponte arsêrunt." The phenomenon, according to Dr. Scott, is of the nature of the "brush" discharge of the electrical machine. It has received many names, such as "St. Elmo's Fire" and "Comozants"—a corruption of "corposants"—from the Latin *corpus sanctum* (Italian, *corpo santo*). Displays of St. Elmo's Fire, accompanied by hissing or loud crackling sounds, are not uncommon at great elevations: on the top of Ben Nevis, in the Alps, and at the high-level observatory on the summit of Pike's Peak in Colorado, United States of America. Pike's Peak, 14,151 feet above the sea, was until lately the highest observatory in the world.

*Colour of Lightning*.—On May 20, 1908, Mr. Spencer C. Russell, F.R.Met.Soc., communicated to the Royal Meteorological Society the results of observations he had made on the colour of lightning at Epsom during the years 1903-1907.<sup>1</sup> Forked lightning was observed in fifty-seven storms, sheet lightning on seventy-eight occasions. In the fifty-seven storms red alone occurred nine times, red and blue eight times, and blue alone seven times. Red and blue in combination with other colours occurred fourteen times, red combined with colours other than blue six times, and blue in combination with colours other than red once. White was twice observed alone, and so was yellow. The greatest

<sup>1</sup> *Quarterly Journal of the Royal Meteorological Society*, vol. xxxiv., No. 148, p. 271. October, 1908.

number of colours seen during a single storm amounted to seven—namely, red, blue, violet, orange, yellow, white, and green. This combination happened on three occasions. Cyclonic thunderstorms in the winter months are accompanied by lightning either red or blue in colour, or in combination. As to sheet lightning, red, yellow, and white alone were each seen on nine occasions. Violet was seen on seven occasions, golden on six, blue and orange on five. In sheet lightning green was the only colour which was not observed alone.

Mr. Russell thinks that the various colours which lightning assumes appear to depend on—(1) The height of the storm-clouds; (2) the electrical energy; (3) the density of the air; (4) the moisture of the air; (5) the presence of suspended matter in the air; and (6) the distance of the flash from the place of observation. In the discussion which followed the reading of Mr. Russell's paper, Mr. W. W. Bryant said that one would expect, for physiological reasons, that, when two flashes occurred at a very short interval, the second would be of the colour complementary to that of the first flash. Storms with frequent flashes would in this way tend to come under Mr. Russell's red and blue class of lightning.

*Hail* is intimately related to atmospheric electricity, as was stated in Chapter XVIII. (pp. 255 and 259). Professor Colladon, of Geneva, considers that the heavy rainfall preceding a hailstorm causes a strong downward current of air, which induces by suction a partial vacuum in the upper clouds. At once a fall of temperature takes place, accompanied by a sudden reduction of vapour tension, which causes a condensation of moisture into frozen particles. These are alternately attracted and repelled by intensely electrified masses of cloud, thus increasing rapidly in size until they become so heavy that they fall to the ground as hailstones. Mr. Colladon supposes that the cloud masses become strongly electrified through the agency of lateral up-draughts of air caused by the central down-draught from the shower of rain preceding the hailstorm. It will be observed that this theory closely agrees with the views of Volta as to the formation of hail referred to in Chapter XVIII. (p. 255).

Mr. Russell, in discussing the colour of lightning, states that

the presence of hail in association with a thunderstorm seems to be intimately connected with blue lightning.

*Aurora.*—This electrical phenomenon is rarely seen in low altitudes or at the Equator. It is a luminous appearance in the northern sky (*Aurora borealis*), or in the southern sky (*Aurora australis*), and assumes most frequently the aspect of an arch of light above a “dark segment” of sky at right angles to the magnetic meridian, from which arch bright rays or luminous pillars, called *streamers*, shoot up with a wavy, quivering motion towards the magnetic zenith. According to Professor Loomis, in America the aurora borealis appears most frequently between latitude 50° and latitude 62° north. In Europe and Asia the auroral region is situated farther north than in America—the region of maximal frequency lying between the parallels of 66° and 75°. In fact, the aurora is seen oftencst within an oval zone surrounding the North Pole, the central line of which zone crosses the meridian of Washington in latitude 56° north, and that of St. Petersburg in latitude 71° north. Auroral displays are therefore more common in America than in Europe. The shape of this auroral zone bears some resemblance to the line of equal magnetic dip, as well as to a “magnetic parallel”—that is, a “line everywhere perpendicular to a magnetic meridian.” Professor Loomis thinks it probable that an auroral display round the North Magnetic Pole of the earth is uniformly attended by a simultaneous display round the South Magnetic Pole. That a connection exists between the aurora and terrestrial magnetism is proved by the extreme agitation of the magnetic needle during an auroral display. In a note, further, on the relation between sun-spots and weather,<sup>1</sup> Dr. R. H. Scott points out that modern observations show that the appearance of an unusually large spot on the sun’s surface is almost invariably accompanied by a “magnetic storm” felt simultaneously in all parts of the globe. When such magnetic storms occur, brilliant displays of the aurora usually take place—the aurora thus also exhibiting a periodicity allied to that of sun-spots, which show epochs of greatest frequency every ten or eleven years. The last epoch of this kind fell in 1902-03.

<sup>1</sup> *Elementary Meteorology*, Appendix V., p. 392. 1883.



In his presidential address on "Atmospheric Electricity," delivered at the meeting of the Royal Meteorological Society, March 21, 1888,<sup>1</sup> Dr. W. Marcet, F.R.S., says that the aurora borealis is now generally considered to be due to positive electricity from the sea between the tropics being carried into the upper atmospheric regions, and thence wafted to the poles by the higher aerial currents. In the vicinity of the poles it descends towards the earth and meets the terrestrial negative electricity in a rarefied atmosphere. Luminous discharges then take place, their brightness being increased by the presence of masses of ice-particles in the atmosphere. These phenomena occur in the neighbourhood of what are called the North and South Magnetic Poles, and from this circumstance assume the form of bands so peculiar to these auroræ.

Researches carried out by Messrs. de la Rue and Müller<sup>2</sup> go to prove that the aurora may appear at any height between a few thousand feet and 80 to 100 miles. Experiments made with M. de la Rue's battery of 11,000 cells established the interesting fact that the colour of the discharge with the same potential varied with, and was apparently determined by, the tenuity of the gas or air. The authors give the following Table of the pressures at which they actually obtained discharges, represented by the corresponding calculated heights, and also of the tints at each height :

Height in Miles.	Tint.	Height in Miles.	Tint.
81·47	Pale and faint	27·42	Carmine
37·67	Maximal brilliancy	17·86	"
33·96	Pale salmon	12·42	"
32·87	Salmon-coloured	11·58	Full red
30·86	" "		

The roseate and salmon-coloured tints are always near the positive source of the electric or magnetic current. The discharge at the negative terminal, in air, is always of a violet hue,

<sup>1</sup> *Quarterly Journal of the Royal Meteorological Society*, vol. xiv., p. 207. 1888.

<sup>2</sup> *Proceedings of the Royal Society*, vol. xxx., p. 332.

and, accordingly, this tint in the aurora indicates the proximity of the negative source.

On Saturday, September 25, 1909, a magnetic storm of unusual intensity swept over the whole earth. Dr. Charles Chree, the Superintendent of the Observatory Department of the National Physical Laboratory at Richmond, Surrey, states that the records at the Observatory show that the disturbance began at 11.22 a.m. on Saturday, September 25, that the magnetic conditions of the earth remained highly disturbed until 8.30 p.m., and that the disturbance had almost disappeared at 1 a.m. on Sunday, September 26. The most remarkable feature of the disturbance was its extremely oscillatory character—a direct evidence that there was aurora well outside the Arctic regions. Clouds interfered with observations over the greater part of the British Isles, but a brilliant display of aurora borealis was reported from Russia, Switzerland, and Northern Italy, while an equally brilliant aurora australis was seen throughout Australia and in South Africa.

In reply to inquiries as to the magnetic storm from the *Times* Correspondent in Birmingham, Sir Oliver Lodge, F.R.S., made the following statement :

“ A cosmic electromagnetic disturbance, such as the earth experienced on Saturday, is now believed to be due to solar radioactivity. For in addition to its ordinary radiation on which the earth entirely depends, the sun is at times technically radioactive, and the eruption not only produces sun spots, but also expels crowds of *electrons*, which fly with prodigious speed in straight lines after the manner of the Beta rays in radium. Whenever a torrent of these minute electrified projectiles rush past the earth, as they do at the rate of some thousand miles a second, they constitute a powerful electric current, and are liable to deflect magnetic needles.

“ Some of them, however, as in the recent case, actually encounter the earth's atmosphere, and though they are mostly deflected to the poles, some of them, especially at the times of the equinox, may come down near the Equator. Those which journey to the poles are accompanied by an opposite current in the crust of the earth from the Equator to the poles, and this it is

which disturbs the telegraphs, being picked up or tapped by them *en route*. They also produce auroras in the neighbourhood of the poles.

“Those which enter the atmosphere elsewhere act as nuclei for condensation of moisture, and by screening the sun’s rays are probably responsible for some of the dull and overcast weather. Local thunderstorms are also a not unlikely result.

“These atmospheric conditions might be mitigated, at least so far as the dull weather is concerned, by artificial supplies of positive electricity to the upper atmosphere in large quantities ; but no one has as yet thought the experiment worth trying on a sufficient scale.

“There is no remedy for the magnetic storms due to cosmic causes, nor for the corresponding earth-currents, but telegraphic disturbance can be eliminated by the use of double lines or return wires.”

*Lightning-Conductors.*—B. Franklin devised the lightning-rod, or lightning-conductor, which is now universally adopted. The principle of the lightning-conductor (French, *paratonnerre* ; German, *Blitzableiter*) is that electricity selects the better of two conducting passages, and that when it has got a sufficient conducting passage, it is disarmed of all destructive energy. A lightning-conductor is a metallic rod, usually of galvanised iron or of copper, which terminates above in one or more sharp points, and below in *moist* earth or in a sufficient expanse of water. This metallic rod, when placed on a building or on the mast of a vessel, protects it by affording a ready passage to the electricity of the earth into the atmosphere, so establishing electric equilibrium gradually and silently. As Dr. R. H. Scott well observes,<sup>1</sup> “The action depends on what is called the ‘power of points.’ The electricity on a sphere is uniformly distributed over the surface ; on an oval figure it tends to accumulate at the ends. On a cylinder this tendency is more strongly developed, and, when the cylinder becomes a fine wire, the tension is so great at the end that the electricity soon forces its way into the surrounding air and escapes.”

A lightning-conductor consists of three parts—the pointed

<sup>1</sup> *Elementary Meteorology*, p. 183.

rod, overtopping the building ; the conductor, or part connecting the top with the ground ; and the part in the ground. In a very able paper, entitled "Remarks on some Practical Points connected with the Construction of Lightning-Conductors,"<sup>1</sup> the late Dr. Robert J. Mann, F.R.A.S., at the time (1875) President of the British Meteorological Society, laid down the indispensable conditions for an efficient lightning-conductor as follows : (1) The lightning-conductor must be made of good conducting material, metallicly continuous from summit to base, and of a dimension which is sufficient for the ready and free conveyance of the largest discharge that can possibly have to pass through it. (2) It must have ample earth-contacts, and these contacts must be examined frequently, to prove that they are not getting gradually impaired through the operation of chemical and electrical erosion. (3) It must terminate above in well-formed and well-arranged points, which are fixed and distributed with some definite regard to the size, form, and plan of the building. (4) There must be no part of the building, whether it be of metal or of less readily conducting material, which comes near to the limiting surface of a conical space, having the highest point of the conductor for its apex, and having a base twice as wide as the lightning-conductor is high, without having a point projecting out some little distance beyond, and made part of the general conducting line of the lightning-rod by a communication with it beneath. (5) There must be no mass of conducting metal, and, above all things, no gas-pipe, connected with the main, within striking distance of the lightning-rod, lest at any time either the points or the earth-contacts shall have been so far deranged or impaired as to leave it possible for discharges of high tension, instead of continuous streams of low tension, to pass through the rod, and to be diverted from it into such undesigned routes of escape.

The Royal Meteorological Society many years ago organised a Conference of delegates from various scientific and professional societies to examine into the whole question of lightning-conductors, and the Conference drew up a code of rules<sup>2</sup> very much on the lines indicated by Dr. Mann in his paper published in 1875. The chief matters to be attended to are these : (1) The

<sup>1</sup> *Quarterly Journal of the Royal Meteorological Society*, vol. ii., p. 417. 1875.

<sup>2</sup> *Report of the Lightning-rod Conference*, p. 16. London : Spon. 1882.



point of the upper terminal should not be sharp, not sharper than a cone of which the height is equal to the radius of its base. All points should be platinised, gilded, or nickel-plated, so as to resist oxidation. (2) Rods should be taken down the side of the building most exposed to rain, and held firmly, but not too tightly, by holdfasts, so as to allow of contraction and expansion by changes of temperature. (3) The rod should consist of copper, weighing not less than 6 ounces per foot-run, and the conductivity of which is not less than 90 per cent. of that of pure copper, either in the form of tape or rope of stout wires, no individual wire being less than No. 12 B.W.G. Iron may be used, but should not weigh less than  $2\frac{1}{4}$  pounds per foot-run. (4) Although electricity of high tension will jump across bad joints, they diminish the efficacy of the conductor; therefore, every joint, besides being well cleaned, screwed, scarfed, or riveted, should be thoroughly soldered. (5) Iron rods should be painted, whether galvanised or not. (6) The rod should not be bent abruptly round sharp corners. (7) As far as practicable, it is desirable that the conductor should be connected to extensive masses of metal, such as hot-water pipes, both inside and outside the building; but it should be kept away from all soft metal pipes, and from internal gas-pipes of every kind. (8) It is essential that the lower extremity of the conductor should be buried in permanently damp soil, hence proximity to rain-water pipes and to drains is desirable.

It is a very good plan to make the conductor bifurcate close below the surface of the ground, and adopt two of the following methods for securing the escape of the lightning into the earth: A strip of copper tape may be led from the bottom of the rod to the nearest water *main*, not merely to a lead pipe, and be soldered to it; or a tape may be soldered to a sheet of copper 3 feet  $\times$  3 feet, and  $\frac{1}{16}$  inch thick, buried in permanently wet earth, and surrounded by cinders or coke; or many yards of the tape may be laid in a trench filled with coke, taking care that the surfaces of copper are, as in the previous cases, not less than 18 square feet. Where iron is used for the rod, a galvanised iron plate of similar dimensions should be employed.

A lightning-conductor should be kept away from a gas-pipe, because if there was any defect in the connections, an electric

discharge of high potential might cause a spark and so ignite the gas.

*The Brontometer.*—In 1890 MM. Richard Frères, of Paris, acting under instructions given by the late Mr. G. J. Symons, F.R.S., made for him an elaborate apparatus, which he called a “Brontometer,” or thunderstorm measurer (Greek, βροντή, *thunder*). A full description of the instrument by Mr. Symons will be found in the *Proceedings of the Royal Society* (vol. xlviii., 1890, p. 65). The traces are made in ink, by a series of Richard pens, on endless paper, 12 inches wide, travelling under the various recording pens at the rate of 1·2 inches per minute, or 6 feet per hour. The first pen records the time, minute by minute. It produces a straight line for fifty-five seconds; then begins to go, at an angle of about 45°,  $\frac{1}{10}$  inch to the left, and at the sixtieth second it flies back to its original position. This movement enables the time of any phenomenon to be read off with certainty to a single second of time. The second pen is driven by one of Richard’s anemo-cinemographs (see p. 285), and gives a tracing of the wind’s force. The third pen, actuated by a handle, indicates the intensity of the rainfall. This movement should be made automatic if possible. The fourth pen is actuated somewhat like a piano. On the occurrence of a flash of lightning, the observer presses a key, the pen travels slightly to the right, and flies back to zero. The fifth pen works in a similar way; but, as it is intended to record the thunder, the observer will continue to hold down the key until the roll is inaudible. Referred to the automatic time-scale, the instant at which these keys are depressed is given to the second. The sixth pen, similar to the third, is intended to record the time, duration, and intensity of hail. The seventh and last pen is devoted to an automatic record of atmospheric pressure.

Owing to the rapid motion of the paper, which is indispensable for studying the details of a thunderstorm, it was imperative that the barometer scale should itself be greatly enlarged. To meet this difficulty, a modification of an ingenious instrument of Richard, called a “statoscope,” was adopted. This measurer of air-pressure “is so sensitive that it will indicate the opening or shutting of a door in any part of a house, gives a scale for 30 inches for each mercurial inch (*i.e.*, about three times that of

a glycerine barometer), and yet requires only 4 inches breadth of the brontometer paper." This wonderful apparatus records accurately .001 inch of mercurial barometric pressure.

Mr. William Marriott, F.R.Met.Soc., has used Symons's brontometer, and the records taken at his residence, West Norwood, London, S.E., during a very severe thunderstorm, on June 4, 1908, are reproduced in a diagram which appears in the number of the *Quarterly Journal of the Royal Meteorological Society* for July, 1908 (vol. xxxiv., No. 147, p. 211). The International Meteorological Conference which took place at Innsbrück in September, 1905, expressed the opinion that autographic thunderstorm recorders—that is, brontometers—are still in the experimental stage, and it consequently could not recommend the general adoption of these instruments at observatories.

*Ozone.*—In 1785 the Dutch physicist Van Marum, while passing a succession of electric sparks from a powerful electric machine through a tube containing oxygen, was attracted by a peculiar odour which developed in the oxygen, and which he attributed to the "electric matter," calling it accordingly the "smell of electricity." In 1840 M. Schönbein, of Basle, named the substance which gave rise to this odour *ozone*, from the Greek ὄζω, *I have a smell*. His views as to the exact nature of ozone passed through several phases. At first he thought it was an element analogous to the halogen group—chlorine, bromine, iodine, and fluorine. Then he considered the possibility of its being a constituent of nitrogen, or a higher oxide of hydrogen, because he found that it could also be produced by the action of phosphorus on moist air (1845). Lastly, in 1852, he came to the conclusion, with other observers, de la Rive and Marignac, that ozone is really oxygen in an *allotropic* state, just as diamond is an allotropic form of carbon, coke or charcoal being the usual forms of this latter element.

This view was fully confirmed by the experimental researches of Dr. Andrews in 1856. He proved that ozone was really an allotropic form of oxygen, and that it was identical in its nature by whatever process it was prepared. Andrews also demonstrated that ozone can be turned back into oxygen by exposing it to high temperatures (300° C.).<sup>1</sup>

<sup>1</sup> *Philosophical Transactions of the Royal Society*, 1856.

In 1858 Schönbein started a new and plausible hypothesis. He announced that ordinary oxygen was a neutral combination of two oppositely electrical and therefore very active bodies. One of these was ozone, or *negative oxygen*, which was formed during the electrification of oxygen or air, the electrolysis of water, the slow oxidation of phosphorus, and the decomposition of most metallic peroxides. He called those substances which evolved this kind of oxygen *ozonides*. The other, the *positive oxygen*, or *antozone*, he failed to isolate, but he assumed its existence in a certain class of peroxides, which he called *antozonides*, examples being the peroxides of hydrogen and barium in particular, also the so-called ozonised turpentine, cod-liver oil, and ether. This ingenious theory was demolished in 1863 by Sir Benjamin C. Brodie.

In 1860 Andrews and Tait presented a very important communication on the subject of ozone to the Royal Society. These observers, in the first place, confirmed a previously known fact, that only a small proportion of oxygen (*one-twelfth*, at most) can be converted into ozone by the electric discharge. But they also found that a constant and considerable diminution of volume accompanied the change—one hundred volumes of oxygen, subjected to the silent discharge, contracting to ninety-two volumes. Hence ozone must be denser than oxygen. Nor was this all, for when mercury, or some other oxidisable substance, was introduced into the ozonised oxygen, and the ozone entirely absorbed, the residual oxygen had precisely the same volume as it had before the removal of the ozone, so that the density of ozone appeared to be absolutely infinite.

Dr. Odling suggested that the formation of ozone might really consist in the condensation of another atom of oxygen into each diatomic or dyad molecule of ordinary oxygen. The chemical formula for free oxygen being  $O_2$ , that for ozone would therefore be  $O_3$ ; and the density of ozone would be one-half greater than that of oxygen. When one hundred volumes of oxygen were reduced by ozonisation to ninety-two, it might be supposed that eight volumes of oxygen combined with sixteen volumes of oxygen to produce sixteen volumes of ozone. The reaction might be represented in this way :





The absorption of the ozone by the mercury, or iodine, etc., might really be only the removal of the third atom of oxygen, which would, of course, leave the volume unaltered—

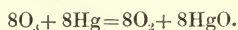

The same view would account for the mutual reduction which ozone and hydrogen dioxide exercise upon one another, and, in fact, for all known reactions of ozone—

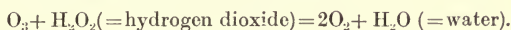

This beautiful hypothesis received a remarkable experimental verification at the hands of M. Soret,<sup>1</sup> who succeeded in finding a body, oil of turpentine, which, instead of removing *only one atom* of oxygen from each molecule of ozone, as most substances do, *absorbs the entire molecule, the whole three atoms of oxygen.* To take our previous illustration, if the ninety-two volumes of ozonised oxygen were treated with oil of turpentine, a dense white cloud would appear, the ozone would vanish, but instead of the volume remaining the same, it would contract to seventy-six volumes, the  $16\text{O}_3$  having been removed bodily, instead of being merely reduced to  $16\text{O}_2$ .<sup>2</sup>

A great number of experiments have given the atomic weight of ozone as twenty-four, and consequently its molecular weight as forty-eight. This is just the weight of three atoms of oxygen—namely,  $16 \times 3 = 48$ , of which, accordingly, it is now universally believed to be composed.

Mr. Francis E. Twemlow, F.M.S., in a paper on ozone, read before the British Meteorological Society on March 17, 1875, indicates the chief points of difference between ozone and ordinary oxygen :

1. It liberates iodine from iodide of potassium.
2. It oxidises rapidly the precious metals.
3. It destroys vegetable colours.
4. It possesses a remarkable smell, like weak chlorine, whilst oxygen is odourless.

Ozone bleaches most vegetable colours, and is a strong oxidiser and so it may be called “nascent,” or “active,” oxygen. The

<sup>1</sup> *Comptes Rendus*, November 27, 1865.

<sup>2</sup> *Medical Times and Gazette*, pp. 383, 384. October 5, 1867.

latter fact probably affords the real clue to the supposed connection between an absence of ozone in the atmosphere and outbreaks of cholera, dysentery, and other like diseases. Their relation attracted the attention of M. Quetelet in Belgium, and of M. Andrand, of Paris, in the cholera outbreak of 1849. According to Glaisher, Moffat, Hunt, and others, the occurrence of cholera and choleraic diarrhoea is coincident with an absence or diminution of ozone, and their departure with a return of ozone (C. B. Fox, M.D.<sup>1</sup>). On the other hand, Dr. Moffat remarks that "the prevalence of influenza, and the spread of catarrhal affections, are invariably connected with an excess of ozone in the atmosphere." The fact is that ozone irritates the mucous membranes, and so has been credited with producing epidemic catarrh.

Although colourless in its gaseous form, ozone appears as a blue fluid when liquefied by cold and pressure. It decomposes a solution of iodide of potassium and sets free iodine, which gives a blue coloration when brought into contact with a solution of starch. Ozone test-papers are strips of blotting-paper or filter-paper steeped in a solution of potassic iodide and starch. When moistened and exposed to an ozone-laden atmosphere, such test-papers turn blue.

Testing for ozone is even still in an unsatisfactory state. Any other oxidising agent in the air, such as hydrogen dioxide or nitric acid, will reduce the potassic iodide, so that the test given above is open to serious fallacy. Dr. Cornelius B. Fox, who has paid particular attention to this question in his work on *Ozone and Antozone*,<sup>2</sup> says that, if we wish to ascertain the amount of ozone present in the air to the exclusion of the other air purifiers, we employ a paper which is *alone* acted upon by ozone, such as the iodised litmus paper. With this test, we do not take any notice of the amount of iodine set free, but we observe the amount of potash formed by the union of the ozone with the potassium. Potash, being an alkali, has the property of turning red litmus blue. The greater or less conversion of the red litmus into blue shows a greater or less quantity of ozone in the air.

<sup>1</sup> *Ozone and Antozone*. London: J. and A. Churchill. 1873.

<sup>2</sup> P. 168. London: J. and A. Churchill. 1873.

## CHAPTER XXII

### INVESTIGATION OF THE UPPER ATMOSPHERE

At the meeting of the British Association for the Advancement of Science held at Winnipeg, Manitoba, Canada, in August, 1909, an important Report was presented by a Committee consisting of Mr. E. Gold and Mr. W. A. Harwood, on the present state of our knowledge of the Upper Atmosphere as obtained by the use of kites, balloons, and pilot balloons. This Report is the most recent comprehensive scientific contribution to the literature of the subject.

In a letter to the editor of *Symons's Meteorological Magazine*, dated July 4, 1896, Mr. A. Lawrence Rotch, F.R.Met.Soc., Director of the Blue Hill Meteorological Observatory, U.S.A., points out that, as far as he knows, kites were first used for meteorological purposes in the year 1749. The credit for introducing this method of investigation belongs to Dr. Alexander Wilson, Professor of Practical Astronomy at Glasgow, who in July of that year, with a student named Thomas Melville, explored the temperature of the atmosphere in the higher regions at Camlachie, near Glasgow, by raising a number of paper kites, 4 to 7 feet in height, one above another upon the same line, with thermometers attached to those which were to be most elevated.<sup>1</sup>

In 1752 Benjamin Franklin, in his historic experiment, obtained electrical discharges from a thunder-cloud by means of a cord carried up to the cloud by a kite.

During the winter of 1822-23 the Rev. George Fisher and Captain Sir Edward Parry, at the island of Igloodik, in the Arctic regions (lat.  $69^{\circ} 21' N.$ , long.  $81^{\circ} 42' W.$ ), obtained tem-

<sup>1</sup> Cf. "The Biography of Alexander Wilson, M.D.," in the *Trans. Roy Soc. Edin.*, vol. x., pt. ii., pp. 284-286.

peratures in the upper air by means of self-registering thermometers attached to kites.<sup>1</sup>

In 1883 Mr. E. Douglas Archibald, at Tunbridge Wells, raised a Biram's anemometer by means of tandem kites. Four of these anemometers were suspended at different levels. They registered on dials the total wind movement during the time they were suspended.<sup>2</sup> Mr. Archibald appears to have been the first person to fly kites with steel wire, although copper wire was so used by Robert Stevenson when a boy.

At the instigation of the British Association for the Advancement of Science, Mr. James Glaisher, F.R.S., shortly after the middle of the nineteenth century, explored the upper regions of the atmosphere by means of balloons. This work was spread over a period of five years, and embraced about thirty ascents, the most remarkable of which was also one of the earliest. His historic balloon ascent was made from Wolverhampton on September 5, 1862, when a height estimated at about 7 miles was reached, and both Glaisher and his aëronaut, Coxwell, narrowly escaped the loss of their lives. Subsequently these "free" ascents were supplemented by others, made with a large "captive" balloon at Chelsea. Glaisher afterwards wrote the article on Aëronautics for the ninth edition of the *Encyclopædia Britannica*, and he edited English translations of works on the subject by the French writers, MM. Tissandier and Flammarion. An article from his pen, on "The Variation of Temperature with Altitude in the Neighbourhood of the Ground," was published in the *Comptes Rendus* of the Paris Academy of Sciences, and in *Nature* in 1877. In an obituary notice in *Symons's Meteorological Magazine* for April, 1903, from which the above particulars are taken, the author, Mr. R. H. Curtis, reminds us that Mr. Glaisher was born so long ago as 1809, and at the time of his death, on February 7, 1903, he was within a couple of months of completing his ninety-fourth year.

In 1898 M. Teisserenc de Bort equipped a kite-station at the

<sup>1</sup> *Symons's Meteorological Magazine*, vol. xxxii., April, 1897, and article, "Meteorology," by G. Harvey, F.R.S., in the *Encyclopedia Metropolitana*, 1834, p. 73.

<sup>2</sup> *Quarterly Journal of the Royal Meteorological Society*, 1883, vol. ix., p. 62; and *Nature*, vol. xxxi., p. 66, and vol. xxxiii., p. 593. Also cf. *British Association Report*, 1884, p. 639; *ibid.*, 1885.



Observatory of Trappes, near Paris. Four years later (1902) kite experiments were made by Mr. W. H. Dines on land, and also over the sea, from a small steam-vessel, on the west coast of Scotland. In 1907 kite-stations were established in Egypt and at Glossop, Derbyshire.

The International Commission of Scientific Aëronautics, at a meeting at Milan in 1906, resolved, on the recommendation of M. Léon Teisserenc de Bort, to carry on, during the years 1907 and 1908, the investigation of the upper atmosphere in the Northern Hemisphere on a much more extended scale than had hitherto been attempted. The Royal Meteorological Society was invited, and agreed, to take part in the scheme, and the matter was placed in the hands of the Kite Committee, consisting of the President and Secretaries of the Society, Colonel J. E. Capper, R.E., Mr. Richard H. Curtis, and Captain Hepworth. This Committee co-operated with a Committee of the British Association, and with the Meteorological Office.

In connection with the investigation of the upper air by the Kite Committee, balloons (*ballons-sondes*) which carried self-recording instruments, and also smaller balloons, were used, the heights and drifts of which were determined by two theodolites placed at the ends of a fixed base.

A thermograph of Richard's pattern, constructed of aluminium by Mr. Fergusson, of the Blue Hill Observatory, was for the first time raised by kites from Blue Hill in 1894; and during the following year meteorographs, recording several elements, were there lifted by the same method. The Blue Hill Observatory was founded and maintained by Professor Rotch, and much of the experimental work was carried on by H. H. Clayton.

When describing the apparatus and instruments employed in ascents of balloons and kites, Messrs. Gold and Harwood observe<sup>1</sup> that the increasing use of captive balloons, which were subject to sudden shocks and jars, of *ballons-sondes* (small free balloons), and of kites, gave a strong impetus to the work of designing really satisfactory self-recording instruments. The light self-recording aneroid barometers, Bourdon tube<sup>2</sup> thermometers, and

<sup>1</sup> Report to the British Association, Winnipeg, August, 1909.

<sup>2</sup> See p. 133.

hair hygrometers of Richard Frères, of Paris, came to be considerably used with kites and *ballons-sondes*. They recorded through levers and metal styles on smoked paper, wrapped round a revolving clockwork drum. They were used with kites at the Blue Hill Observatory, Massachusetts, U.S.A., alongside a meteorograph designed by Fergusson, which included also an anemometer; and by Hermite and Besançon with *ballons-sondes* in the years 1893 to 1898.

The type of instrument finally evolved for use with *ballons-sondes* had (1) a completely exhausted Bourdon tube<sup>1</sup> barometer,

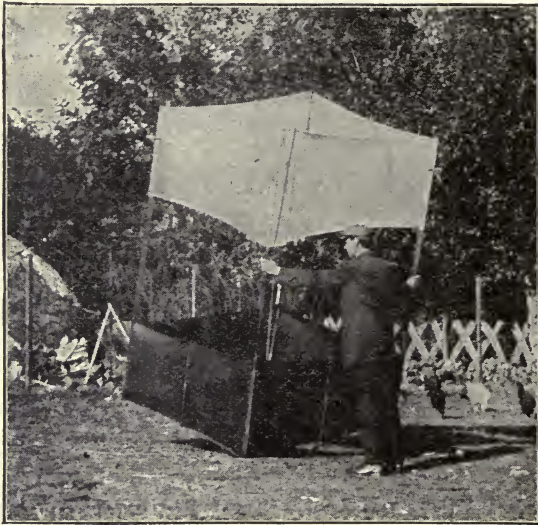

FIG. 89.—KITE CONSISTING OF TWO STRIPS OF MATERIAL STRETCHED INTO QUADRANGULAR SAILS ON A LOZENGE-SHAPED PLAN UPON FOUR TRANSVERSE BARS KEPT APART BY TWO PAIRS OF CROSS-STRUTS.

which was found to show less fatigue effect than the aneroid barometer; (2) Teisserenc de Bort's bimetallic thermometer—consisting of a blade of German silver fixed in a frame of Guillaume steel, which had small thermal inertia (requiring only fifteen seconds to indicate a sudden change of temperature of 9° C.), and which was not affected by shocks—and Hergesell's German-silver tube thermometer; (3) a hair hygrometer. The working parts of the instrument were enclosed in an aspiration-tube. Similar instruments were designed for use with kites.

<sup>1</sup> See p. 133.

The principal self-recording instruments which have at various times been used have been designed by Richard Frères, C. F. Marvin, Fergusson, L. Teisserenc de Bort, R. Assmann, H. Hergesell, and W. H. Dines. Richard, Marvin, Hergesell, and Dines designed instruments for use with kites; and Richard, Teisserenc de Bort, Assmann, Hergesell, and Dines, *ballons-sondes* instruments.

Special balloon ascents were made in 1907, on July 22 to 27, September 4 to 6, and November 6 to 8. Reports on the International Balloon Ascents of July 22 to 27, 1907, by W. H. Dines, F.R.S., J. E. Petavel, F.R.S., W. A. Harwood, and Professor W. E. Thrift, M.A., Fellow of Trinity College, Dublin, will be found in the number of the *Quarterly Journal of the Royal Meteorological Society* for January, 1908.<sup>1</sup>

The instruments — Dines's light meteorographs — which were used are described in *Symons's Meteorological Magazine* for July, 1906,<sup>2</sup> while a detailed account of Dines's instruments and methods is contained in *The Free Atmosphere in the Region of the British Isles* (Meteo-

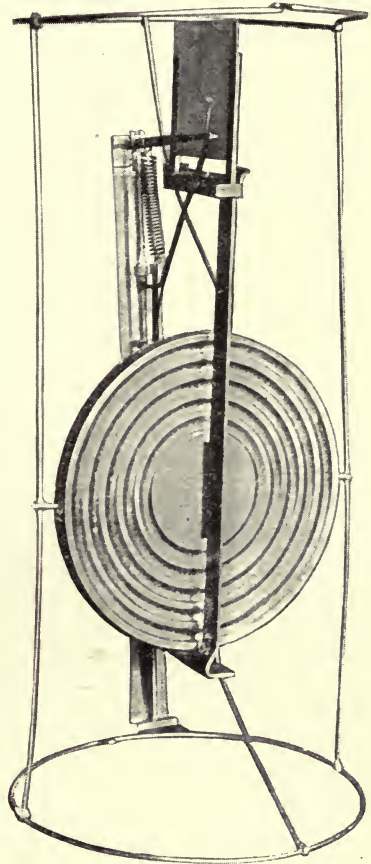

FIG. 90.—DINES'S BALLOON METEOROGRAPH.

logical Office Publications, No. 202). Briefly, it may be said that Dines's light meteorograph is a baro-thermograph, no measurements of humidity being attempted. The barometer

<sup>1</sup> Vol. xxxiv., No. 145, p. 1.

<sup>2</sup> Vol. xli., p. 101.

is, in general, a partially exhausted German-silver aneroid, and the thermometer is bimetallic, consisting of a strip of aluminium or German-silver and a rod of invar. The partially exhausted aneroid is used because it gives a larger scale than the totally exhausted box, and leaves a record scratched by two hard steel points on a small piece of sheet metal electro-plated with copper (Fig. 91). The scale is very small, but the traces are read under a low-power microscope. The marks consist of two lines roughly parallel; at least, they would be parallel were there no change of temperature. In the usual form of trace, these lines are about  $\frac{1}{2}$  inch (12 millimetres) long, and start about  $\frac{1}{30}$  inch

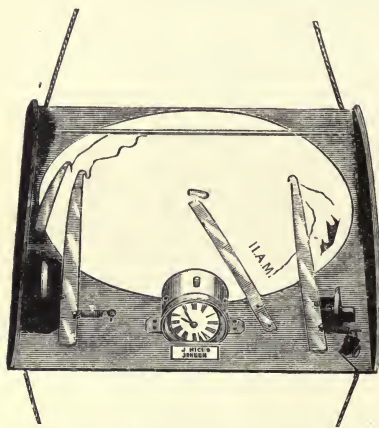

FIG. 91.—RECORDING PLATE OF DINES'S METEOROGRAPH.

apart, diverging to perhaps  $\frac{1}{10}$  inch at the top. The distance between the lines gives the temperature. Under a microscope it is easy to read this distance to about  $\cdot 001$  inch (or  $\cdot 025$  millimetre), and this distance corresponds to about  $1^{\circ}$  C. The record of height is more uncertain. The atmospheric pressure recorded can be ascertained with fair accuracy, but heights where the pressure amounts to only a few inches of mercury (under 150 milli-

metres) are frequently reached, and at such heights—40,000 feet and upwards—a small error in the pressure means a large error in the height.

The heavier of the meteorographs weighs  $3\frac{1}{2}$  ounces (100 grammes). In the second and lighter form of instrument, which weighs 1 ounce (28 grammes), the thermometric arrangement consists of a round steel (invar) rod and a strip of very thin aluminium, both 6 inches long; and their difference in length, which is multiplied about twenty times by a lever, produces the varying distance between the scratches.

As regards the balloon ascents of July, 1907, balloons carrying



recording instruments—the 1-ounce Dines's meteorographs—were sent up at 11 a.m. daily between July 22 and 28 from Manchester.

The balloons were observed from three trigonometrical stations, unfortunately in unfavourable hazy weather. Indiarubber balloons of the nominal size, 2 feet (60 centimetres) diameter, were used. These were filled to about 39 inches (1 metre) diameter. The instruments, together with instructions to the finder, were attached to a small silk parachute (11 inches square), suspended some 6 feet below the balloon. On July 23 the temperature of the air at the time of the ascent at Manchester was  $59^{\circ}$  F.; at a height of 40,000 feet it was  $-52^{\circ}$  F. The ascents confirm the interesting theory put forward by M. Teisserenc de Bort with regard to the existence of a nearly isothermal layer above some 6 miles (10,000 metres).<sup>1</sup> His results were confirmed immediately afterwards by Dr. Richard Assmann, Director of the Royal Prussian Aëronautical Observatory, Lindenberg, Germany.<sup>2</sup> Its existence over North America was demonstrated by Mr. A. L. Rotch. Teisserenc de Bort found the average height at which the change occurred to be about 11 kilometres. He discovered also that the height was greater near centres of high atmospheric pressure than near centres of low pressure, the average heights for the two cases being 12·5 and 10 kilometres respectively. Later observations agree on the whole with these results. Between the ground-level and a height of about 5 miles the temperature falls continuously. The average gradients over this range varied during the week of the ascents between  $0\cdot28^{\circ}$  and  $0\cdot33^{\circ}$  C. per 100 feet ( $0\cdot5^{\circ}$  and  $0\cdot6^{\circ}$  C. per 100 metres). Above 7 miles all the Manchester curves show a more or less marked temperature inversion. In his report, read before the Royal Meteorological Society on November 20, 1907, Mr. W. H. Dines remarks that “the thirty-four successful ascents that have been made in England since June last (1907) have, in my opinion, proved conclusively the existence of the isothermal conditions above some  $7\frac{1}{2}$  miles (12,000 metres).” The heights attained by the balloons ranged to over  $12\frac{1}{2}$  miles (20 kilometres), the average being about  $7\frac{1}{2}$  miles (12 kilometres).

<sup>1</sup> *Comptes Rendus*, April, 1902, vol. cxxxiv., pp. 987-1000; January, 1904, vol. cxxxviii., pp. 42-45; July, 1907, vol. cxlv., pp. 149-152, etc.

<sup>2</sup> *Ergebnisse aëronautischen Obs.*, Berlin, May, 1902.

In the international balloon ascents of July, 1907, England headed the list for height with two ascents at Manchester of 69,000 feet (21,000 metres); and out of nine ascents of over 65,000 feet (20,000 metres), four took place in England.

During July and August, 1908, balloon observations were made at Birdhill, Co. Limerick, Ireland, by Captain C. H. Ley, F.R.Met.Soc. Twenty-five balloons were despatched, including seven registering balloons, which latter were sent up on the international days in July—namely, the 2nd, 27th, 28th, 29th, 30th, and 31st. One of the balloons was observed, by means of an 8-inch special theodolite, to a height of nearly 33,000 feet; four were observed to over 20,000 feet; seven to over 15,000 feet; and four to over 10,000 feet. As regards horizontal distance, several balloons were observed to 126,000 feet (24 miles), and one to an actual range of 130,000 feet. This may be considered the practical limit of vision on an opaque balloon  $2\frac{1}{2}$  feet in diameter with a 35-power telescope in a clear atmosphere. A feature developed during the course of the experiments was the observation of balloons at night by means of naked acetylene lights. After some trouble, these proved quite successful, gave long runs with less risk of being lost in small clouds, and afforded points of light which could be observed with great accuracy.<sup>1</sup>

Investigations of the variations in velocity and direction of wind in the great middle strata of the atmosphere by means of balloons followed by special theodolites were also made by Captain Ley in the summer of 1907 at Sellack, about 3 miles north-west of Ross, Herefordshire. The formulæ used for theodolite calculations were the following:

$$1. h = a \frac{206085d \sin A}{B}.$$

$$2. h. d. = h \cot A,$$

where  $h$  = vertical height in feet.

$h. d.$  = horizontal distance in feet.

$d$  = diameter, in feet, of balloon at start.

$A$  = angle of altitude (to minutes).

$B$  = observed diameter in seconds.

$a$  = expansion percentage.

<sup>1</sup> *Quarterly Journal of the Royal Meteorological Society*, January, 1909, vol. xxxv., No. 149, p. 15.

A direct estimation of range of the balloon from its apparent diameter, as measured by cross-threads in a telescope, of which the aperture was 1·9 inches and the focal length was  $13\frac{1}{2}$  inches, was also made.

Based on this series of balloon observations, Captain Ley read a paper on the possibility of a topography of the air before the Royal Meteorological Society on December 18, 1907.<sup>1</sup>

Systematic investigations of the upper air are now carried out at four British stations by means of kites and balloons. These stations are :

1. Pyrton Hill, near Watlington, Oxfordshire, 500 feet above sea-level.
2. Ditcham Park, near Petersfield, Hampshire, 400 feet.
3. Brighton, Sussex, 380 feet.
4. Glossop Moor, Howard Estate, Peak District, Derbyshire, 1,100 feet.

The work is under the general direction of Mr. W. H. Dines, F.R.S., who has designed most of the special apparatus in use.

The work carried on may be classified under five heads :

1. Observations by means of kites.
2. Observations by means of registering balloons.
3. Observations by means of pilot balloons followed by one or more theodolites.
4. The making of apparatus and instruments for use at Pyrton Hill and other stations.
5. Calibration of the instruments and working up the records obtained.

The kites carry meteorographs, which give a continuous record of temperature, wind velocity, humidity, and height.

At the meeting of the Royal Meteorological Society held on November 20, 1907, a paper was read, written jointly by Miss Margaret White, Mr. T. V. Pring, and Mr. J. E. Petavel, F.R.S., in which the authors discussed the observations (some 5,000 in number) made at the British kite-stations during the session of 1906-1907.<sup>2</sup>

<sup>1</sup> *Quarterly Journal of the Royal Meteorological Society*, January, 1908, vol. xxxiv., No. 145, p. 27.

<sup>2</sup> *Quarterly Journal of the Royal Meteorological Society*, January, 1908, vol. xxxiv., No. 145, p. 15.

To the Third Annual Report of the Meteorological Committee for the year ended March 31, 1908, Mr. Dines contributed a report on the work done during that year at the Pyrton Hill station, a little over 14 miles south-east by east of Oxford, and on the north-western slope of the Chiltern Hills. During the year April 1, 1907, to March 31, 1908, 113 kite ascents were accomplished, and the average height was 3,500 feet. The first registering balloon was sent up on June 5, 1907. Up to March 31, 1908, twenty such balloons had been despatched, of which fifteen were found, though only fourteen records were obtained, because in one case the finder abstracted the meteorograph, and returned only the empty case.

In general, rubber balloons weighing 8 ounces (227 grammes) are used singly: they are filled with hydrogen, and at starting have a radius of about 19 to 20 inches ( $\frac{1}{2}$  metre). They carry a meteorograph, which, with a bright metal cylindrical case, weighs just 2 ounces. The parachute is made out of very thin red silk, 10 inches square, with a  $1\frac{1}{2}$ -inch hole, and threads running from the four corners to a thin wire cross. Apart from the balloon, the total weight to be carried is  $2\frac{1}{2}$  ounces, and a free lift of about 10 ounces is generally given. This affords an ascensional velocity of from 600 to 700 feet per minute. The average height attained has been 48,500 feet (14.8 kilometres), and in most cases the isothermal layer has been reached. The balloons are sent up a short time before sunset.

Up to April 2, 1908, forty-five records had been obtained from these meteorographs by balloons sent up either from Pyrton Hill, Manchester, Ditcham Park, Sellack in Herefordshire, or Crinan in Argyllshire. The map (Fig. 92) shows the geographical positions from which the instruments were returned by the finders. Fig. 93 shows the relation between temperature and height obtained from the results. The diagram on the small scale of the reproduction is too confused for the individual curves to be traced, but three points may be made out: (1) A notable complication within the first 2 miles above the surface; (2) remarkable parallelism in the slope of the curves, showing nearly identical temperature gradients up to 10 or 12 kilometres; (3) the isothermal layer above 12 kilometres. The figures are reproduced



## Investigation of the Upper Air 1907-8

Map showing the positions at which Sounding Balloons sent up from the following stations have been found

- Crinan ⊙
- Manchester □
- Sellack X
- Pyrlton Hill ○
- Ditcham Park △

The circles round the several stations represent a radius of 25 miles

Corresponding dates are indicated by the same number.

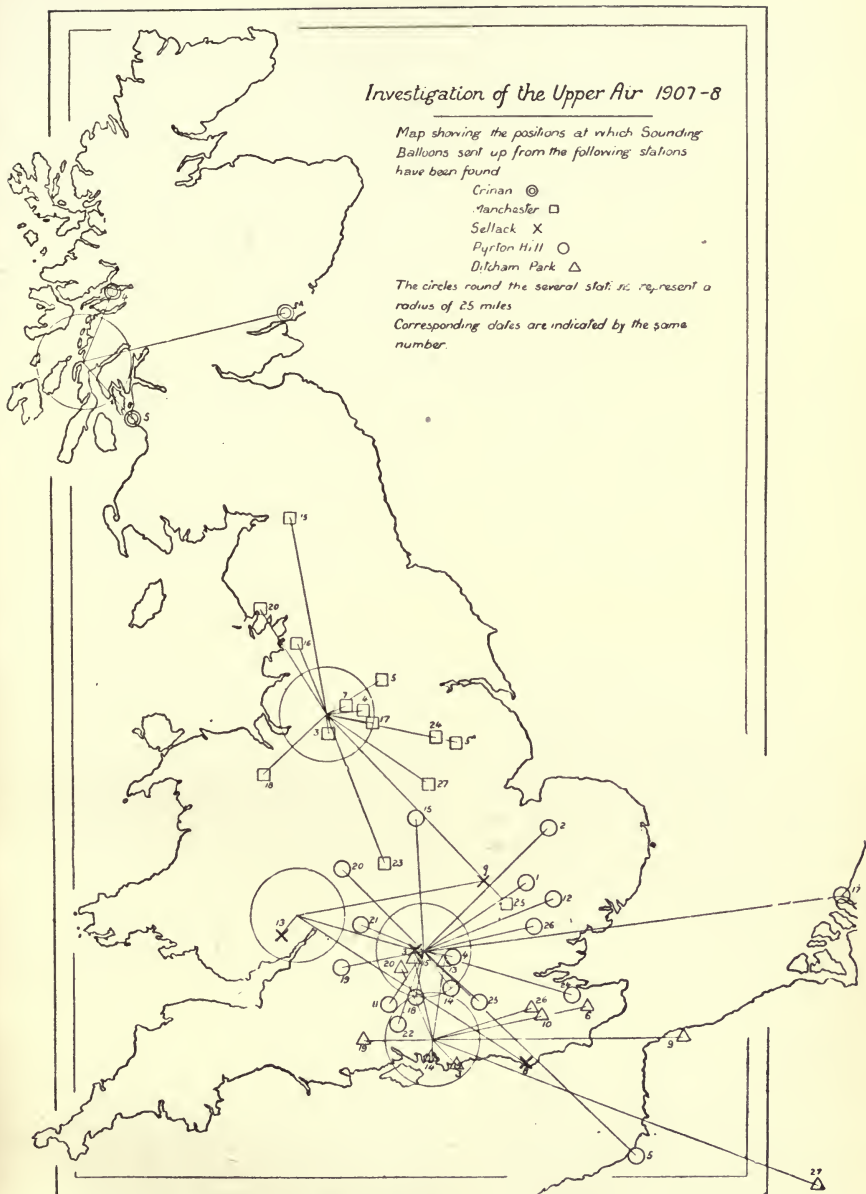

FIG. 92.—MAP SHOWING THE POSITIONS AT WHICH SOUNDING BALLOONS SENT UP FROM CERTAIN OBSERVING STATIONS IN 1907-1908 WERE FOUND.

by the kind permission of the Controller of His Majesty's Stationery Office, London.

"Perhaps the most remarkable phenomenon revealed by the investigation of the upper air with balloons carrying self-recording instruments," write Messrs. Gold and Harwood, "is the comparatively sudden cessation of the fall of temperature at a height varying with the time and the latitude. Above this height, which may be regarded as the height of an irregular but roughly horizontal surface dividing the atmosphere into two regions, the temperature at any time varies very little in a vertical direction, showing on the average a slight tendency to increase. This comparative absence of regular vertical variation of temperature in the upper region led to the name 'isothermal layer or region,' to distinguish it from the lower atmosphere, in which the vertical variation of temperature is about 6° C. per 1,000 metres."

The upper region has been usually described as the "isothermal layer," but Teisserenc de Bort has recently introduced the terms "stratosphere" and "troposphere" to denote the upper and lower regions respectively.

It is difficult to form a mental picture of the condition of the atmosphere to be inferred from observations at different places on the same day, and in order to help towards that object Dr. Shaw has constructed a model of the block of the atmosphere over the area of observation in the British Isles for each of the two days, July 27 and July 29, 1908, on which observations were taken on an extended scale. Simultaneous soundings by balloons (*ballons-sondes*) gave data for temperature up to great heights at the corners of a triangle, about 300 miles in the side. The observations used in the representation are from records of balloons sent up at Petersfield (Hants), Watlington (Oxon), Crinan (Argyll), and Limerick, on the 27th; and at Watlington, Manchester, Crinan, and Limerick on the 29th, together with additional observations of a pilot balloon at Petersfield on the 29th.

A frame of vertical plates of glass represents a block of atmosphere, 15 miles thick, standing on the triangle. The horizontal scale of the original models is 25 miles to an inch, the vertical scale 5 miles to 4 inches. The observed temperatures are set

PLATE III.

TEMPERATURES AND PRESSURES IN A BLOCK OF ATMOSPHERE FIFTEEN MILES THICK  
OVER A PORTION OF THE BRITISH ISLES. JULY 27<sup>TH</sup> AND 29<sup>TH</sup> 1908.

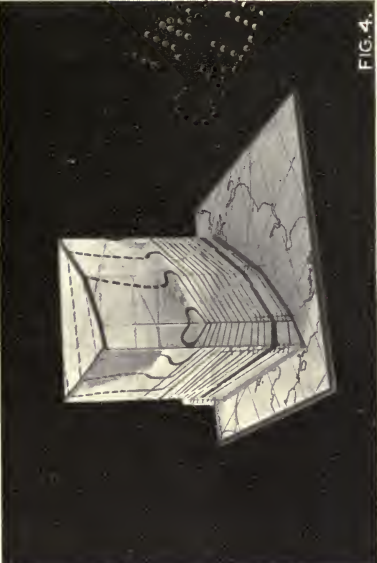
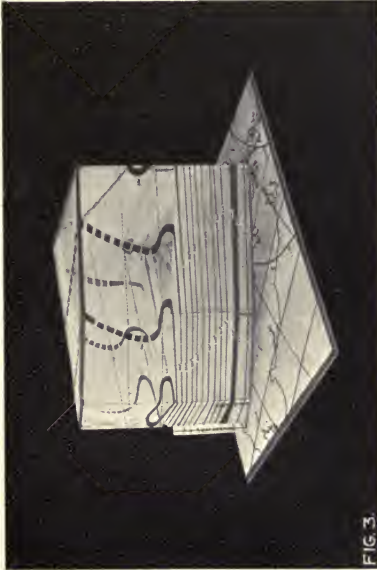
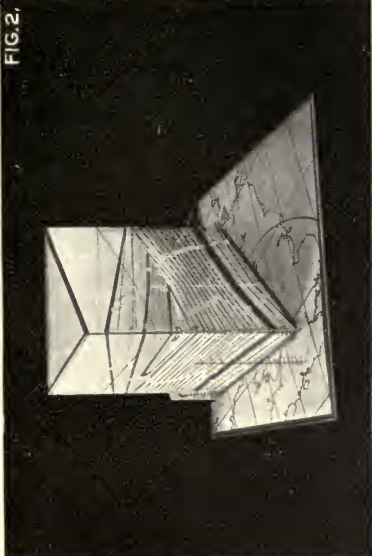
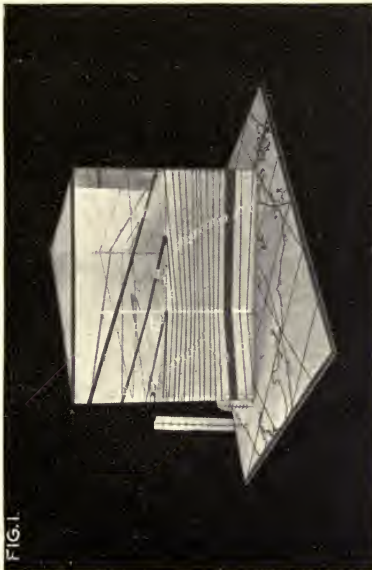



21



CURVES SHOWING CHANGE OF TEMPERATURE WITH HEIGHT ABOVE SEA-LEVEL OBTAINED FROM BALLON-SONDE ASCENTS 1907-8.

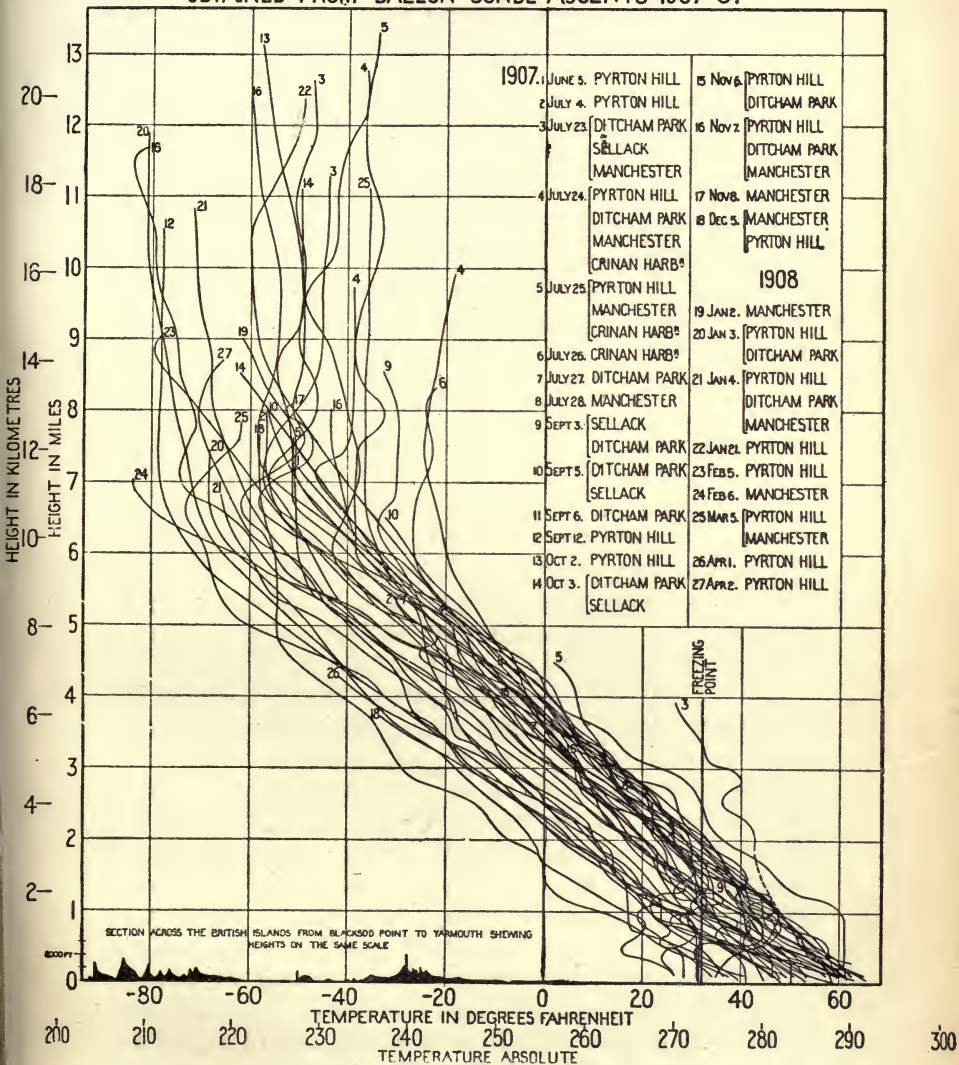

FIG. 93.—SHOWING THE RELATION BETWEEN TEMPERATURE AND HEIGHT OBTAINED BY THE ASCENTS OF "BALLONS-SONDES."

out at the angles. The distortion due to the horizontal drift of the balloons is neglected. Points of equal temperature are joined by lines on the glass sides; the thickness of the lines is adjusted to cover half a degree of temperature. These isothermal lines are drawn for every  $5^{\circ}$  C., and the space between the two lines on either side of the freezing-point, to be found at a height of about 3 kilometres, is filled in so that it appears as a thick band in the photographs.

The lines as thus drawn suggest the distribution of temperature "in the solid." They give a vivid representation of the reversal at the top of the troposphere. The temperature of the closed ring shown at the south-eastern angle (Petersfield) on the 27th (Plate III., Figs. 3 and 4) is  $-58^{\circ}$  C., and that of the smaller closed ring on the 29th (Plate III., Figs. 1 and 2) at an angle (Watlington), which is nearly identical, is  $-68^{\circ}$  C. On the 27th the isothermal lines indicate a wedge of cold air ( $-58^{\circ}$  C.) invading the block at the reversal layer near the south-east corner. On the 29th the cold wedge is shown nearly covering the triangle. Lines of equal pressure are drawn in red on the original models to show the levels of one-fifth and one-tenth of an atmosphere; they are shown as beaded lines on the photographs.

Winds, as far as they are known from observations of pilot balloons, are shown by means of arrows representing wind vanes, mounted on long vertical pins.

Messrs. Gold and Harwood point out that the absence of vertical temperature fall in the upper atmosphere implies that general direct convection in that region is also absent, and that, in general, interchange of air in the stratosphere would be mainly by advection. They accordingly suggest that the two regions of the atmosphere might be approximately named *advective* and *convective* regions, so expressing the characteristic difference between them. The terms "convective" and "advective" need somewhat more detailed explanation, which I can best give in Mr. Gold's own words in answer to a query addressed to him by me.

If a quantity of matter undergoes changes such that no transference of heat takes place between it and external matter, the changes are said to be *adiabatic* (Greek, *ἀδιάβατος*, *not to be passed*). If the transference of air from one level in the atmo-

sphere to another takes place adiabatically, the difference of temperature between the two places is proportional to their difference of level. It is equal to  $9^{\circ}$  C. for a height of 1 kilometre. If the air is saturated with water vapour, the difference of temperature is no longer strictly proportional to the difference of level. Near the earth's surface the difference is nearly  $5^{\circ}$  C. per kilometre, but it increases with increasing height. Of course, it is always less than  $9^{\circ}$  C.

If the motion of the atmosphere consists of vertical currents or of horizontal currents with considerable vertical interchange, it is said to be in the *convective* state. It must then be also approximately *adiabatic*. *Adiabatic* and *convective* are frequently used as interchangeable terms, although they are not strictly so. The idea implied by "convective" is that vertical interchange is the dominating factor in determining the vertical distribution of temperature.

If vertical interchange is practically absent and the atmospheric currents are nearly altogether horizontal, the state is said to be *advective*. Of course, there will be some vertical interchange as long as there are horizontal currents, but the vertical motion will exercise only a secondary influence on the temperature distribution.

In a paper recently published,<sup>1</sup> on "Vertical Temperature Gradients of the Atmosphere, especially in the Region of the Upper Inversion," Professor W. J. Humphreys arrives at the following (among other) conclusions :

1. Considered from the standpoint of temperature gradients, the explored portion of the atmosphere is divisible into three parts : (1) The region of terrestrial disturbance, extending from the ground to an elevation of about 3,000 metres above its surface ; (2) the region of uniform changes, from the top of (1) to, roughly, 10,000 metres above the sea ; (3) the region of permanent inversion, or all that explored portion, at least, that lies above the plane of the upper inversion.

2. Spectroscopically, the known atmosphere is divisible into three parts : (1) The black body portion, coincident with the region of, and due to, the relatively dense water vapour ; (2) the

<sup>1</sup> *Bulletin of the Mount Weather Observatory*, March 24, 1909, vol. ii., pt. i. Washington, U.S., Weather Bureau.

diathermanous, or the dry air next above the water vapour ; (3) the selectively absorptive, or the air of the isothermal layer, presumably rich in ozone.

On December 10, 1908, Dr. W. N. Shaw communicated to the Royal Society a paper by E. Gold, M.A., Fellow of St. John's College, Cambridge, and Reader in Meteorology, on "The Isothermal Layer of the Atmosphere and Atmospheric Radiation."<sup>1</sup> Having shown that there can be no question of the isothermal layer of the atmosphere being merely a local or temporary phenomenon, Mr. Gold states that it is clear that there cannot be convection currents to any marked extent in this region. He proceeds to show that in an atmosphere which is not transparent, but absorbs and emits radiation, the process of radiation would prevent the establishment of the temperature gradient necessary for convective equilibrium in the upper layers of the atmosphere, and that in the lower layers of our atmosphere it can be maintained only by transference of energy from the earth to the atmosphere by direct convection or by the process of evaporation of water at the earth's surface, and subsequent condensation in the atmosphere. The heat necessary for the evaporation of water vapour at the earth's surface is supplied mainly by absorption of solar radiation, and is not taken from the atmosphere, but the heat given up on condensation is added almost entirely to the heat of the atmosphere, and in this way we get a supply of heat to the atmosphere at a rate that may be estimated approximately from the annual rainfall.

The attempts to furnish a reasonable explanation of the phenomenon on theoretical grounds led to various suggestions. Trabert<sup>2</sup> showed that if there were a decrease of temperature in a horizontal direction in passing eastwards over Europe, and if the air moving eastwards also had a small ascending motion, then the adiabatic fall of temperature would not exist in a vertical direction. It appears probable, however, that the causes which produced a horizontal decrease of temperature in one layer would also produce a similar decrease in the layer above it, and in that case Trabert's effect would vanish.

<sup>1</sup> *Proceedings of the Royal Society*, A. vol. lxxxii., p. 43.

<sup>2</sup> *Met. Zeit.*, 1907.



Fenyi<sup>1</sup> considered the question of the absorption of solar radiation in the upper atmosphere. He concluded that, if the phenomenon were due to this, there must be absorption of dark radiation, since the ultra-violet radiation would be insufficient even if it were all absorbed. Humphreys<sup>2</sup> pointed out that, if the effective radiating power of the earth and atmosphere were the same as that of a black body at temperature  $T_1$ , the effect on any radiating and absorbing matter near enough to the earth for the radiating surface to be regarded as an infinite plane would be to keep the matter at a constant temperature, such that the radiation from it would be half the radiation from it at temperature  $T_1$ . If the radiating matter were such as to admit of the application of Stefan's law, its temperature would be  $T$ , where  $T^4 = \frac{1}{2}T_1^4$ .

From a careful examination of the results of MM. Dulong and Petit's classical experiments as to the laws of cooling (*Annales de Chimie et de Physique*, 2<sup>e</sup>, tome vii., pp. 225 et 337, 1817), M. J. Stefan was led to the conclusion that the total radiation emitted by any body is proportional to the fourth power of the absolute temperature of the body.<sup>3</sup>

This was shown by Boltzmann to be a necessary relation from thermodynamic considerations. "Thus, if  $T$  is the absolute temperature of a 'black' body," writes Mr. E. Gold, "and  $R$  the number of units of energy radiated from unit surface of it in unit time, then—

$$R = \sigma T^4."$$

This is Stefan's Law. "The law strictly applies only to a black body, which means a body radiating for every wave-length, and capable of absorbing all the energy of any wave-length which falls upon it from an external radiation. Such a 'body' radiates as much energy at a given temperature as it is possible for any 'body' to radiate. Of course, it would be possible for the law to apply also to other bodies which radiated, say, a definite fraction for all wave-lengths of the radiation of a black body. It has

<sup>1</sup> *Met. Zeit.*, 1907.

<sup>2</sup> *Astrophysical Journ.*, 1909.

<sup>3</sup> *Sitzungsberichte d. k. Akademie der Wissenschaften in Wien*, vol. lxxix., 1879; and *Journal de Physique*, tome x., p. 317, 1881. Cf. Preston's *Theory of Heat*, 1894, p. 458.

been suggested that such bodies might be called 'gray' bodies." The whole subject is treated clearly and simply in Poynting and Thomson's *Heat*.

The observed value of  $T$  agrees with the value deduced from this equation by giving  $T_1$  the value estimated by Abbott and Fowle<sup>1</sup> from the value of the solar constant, regard being paid to the proportion of the incident solar radiation which is reflected, and does not affect the temperature of the earth.

Gold<sup>2</sup> developed a theory based on the experimental results for atmospheric absorption obtained by Paschen and others. His argument rests on the principle that a necessary condition for convection is that in the upper part of the convective system the radiation from any horizontal layer must exceed the absorption by it. He takes the temperature in the convective region to be given with sufficient approximation by the equation  $T^1 = kp$  where  $n = 4$  and  $p$  is pressure, and represents the radiating power of the atmosphere by  $a = 1(q - p)$ , where  $a$  and  $q$  are constants, in order to allow for the diminution with height arising from the decrease in the amount of water vapour present.<sup>3</sup> He finds that

<sup>1</sup> *Annals of Observatory of Smithsonian Institution*, vol. ii.

<sup>2</sup> *Proceedings of the Royal Society*, A. vol. lxxxii.

<sup>3</sup> Messrs. Gold and Harwood state that it has been suggested that the upper limit of the convective region may be also the upper limit of the water vapour atmosphere. But it appears certain that at this upper limit the atmosphere must always be saturated with water (ice) vapour, and that in the advective region the water vapour atmosphere will be such that the difference of vapour pressure between two points will be equal to the weight of the vapour in the intervening column. For the processes of diffusion and of convection of water vapour alone would tend to produce a water vapour atmosphere, in which the amount of vapour present at any height in the convective region would be more than sufficient to produce saturation at that height for the temperature in the actual atmosphere. The only process which prevents the atmosphere being saturated at all heights is the descent of air carrying with it the water vapour it contained at the beginning of the descent, an amount insufficient to saturate it at lower levels. But at the upper limit of the convective region there can be no considerable descent of air from above, and the air arriving there from below will necessarily be saturated, since it must contain sufficient water vapour to saturate it at the lowest temperature to which it has been exposed—*i.e.*,  $T_c$ . Of course, the actual amount of water vapour present is small compared with the amount present near the earth's surface; but a small amount of water vapour is sufficient, at ordinary temperatures at least, to produce considerable absorption of terrestrial radiation, and the absorption extends through a large part of the spectrum of radiation at terrestrial temperatures. In fact, it is probably chiefly due to the presence of this water vapour that it is possible to obtain theoretical results agreeing with the observed facts by using the assumption that the absorption, and therefore

for an atmosphere of uniform constitution the adiabatic state cannot exist to a height greater than that for which  $p = \frac{1}{2}p_0$ , where  $p_0$  is the surface pressure, because if it extends at any time to a greater height, the absorption in the upper part will exceed the radiation. He shows that for the actual atmosphere the adiabatic state can exist to a limited height only, and that if the atmosphere consist of an adiabatic and an isothermal region the adiabatic state must extend to a height greater than 5.5 kilometres, and cannot in general extend to a height greater than 10.5 kilometres. He shows also that the radiation from the lower half of the convective region exceeds the absorption by it, and deduces that its temperature must be maintained by convection from the earth's surface and by condensation of water vapour. It follows also from the theory that, if in the upper region the temperature increases with the height, the conditions for thermal equilibrium are satisfied if the convective atmosphere extends to a height greater than that for the case of an isothermal upper region—*i.e.*, the limits for  $H_c$  are greater than 5.5 and 10.5 kilometres.

Shaw<sup>1</sup> has recently considered the connection between a depression of the lower surface of the advective region and the temperature distribution in that region. He finds that if such a depression is produced artificially or through a disturbance in the convective region, the first effect will be to produce a horizontal difference of temperature in the advective region. If the advective region is initially isothermal, it will still be *vertically* isothermal, but the temperature of the vertical columns will not be the same for all. Over the depression the temperature will be raised. He finds that the value of  $H_c$  is diminished by 3.5 times the difference of height of the "homogeneous" stratosphere at the normal and increased temperatures. If the increase of temperature is 20° C., the decrease in  $H_c$  is about 2 kilometres.

At the Winnipeg meeting of the British Association, on

---

also the radiation, is sufficiently extensive to warrant the application of Stefan's law. It follows, also, from this reasoning that the mean amount of vapour present at any height above the lower cloud level will be at least half the sum of the amount for saturation at that height, and the amount necessary for saturation at the height  $H_c$ —namely, the height of the dividing surface between the advective and convective regions.

<sup>1</sup> *Perturbations of the Stratosphere*, Publications of the Meteorological Office, No. 202. 1909.

August 31, 1909, to the department of Section A. (Mathematics) devoted to Cosmical Physics, Professor Humphreys, of the United States Weather Bureau, communicated a paper on "Seasonal and Storm Vertical Temperature Gradients." The paper dealt mainly with results obtained by *ballons-sondes* in Europe, and showed that in regions of high pressure (pressure above 770 millimetres, or 30.3 inches) the mean temperature was higher than in regions of low pressure (pressure < 750 millimetres, or 29.5 inches) both in summer and winter. This result is in agreement with that found from the manned-balloon observations by von Bezold, and is corroborated by the results given by Gold and Harwood in their Report on the Present State of Our Knowledge of the Upper Atmosphere. In this Report, as has been explained above, the names "Advective" and "Convective" Regions are used to denote the upper and lower parts of the atmosphere, and  $H_c$  is used to denote the height at which the advective region begins.

The three sets of terms applied to the same phenomena are therefore :

Isothermal Layer.

Adiabatic Atmosphere.

Stratosphere.

Troposphere.

Advective Region.

Convective Region.

The European observations showed remarkable minima in the value of  $H_c$  in March and September, and an attempt was made in the Report to connect these with the general circulation of the atmosphere. The interesting law discovered by Egnell,  $V\rho = \text{const.}$  where  $V$  is wind velocity and  $\rho$  air-density, was shown to be only approximately true, and was proved to be a consequence of the difference in temperature between regions of high and low pressure.

H. Hergesell's exploration of the upper atmosphere over the Northern Atlantic showed that the temperature distribution in the vertical was very irregular, and not like that in the lower latitudes. The higher strata of the air were, on the whole, rather warmer, probably owing to the continued heating by the Arctic sun. Immediately above the sea the temperature frequently fell rapidly, while the humidity rose—a bank of clouds would limit this stratum. On the Island of Spitzbergen strong land winds were very persistent, blowing in the same direction even at night, especially with a bright sky.



In the Wijde Fjord, which penetrates 100 kilometres southward into the land, the wind blew almost constantly at 7 metres per second from the south. But these cold winds from the glaciers were purely local, and died away over the open sea: they were confined to the lower strata of a few hundred metres, above which kites would not rise. In the higher strata the winds were much stronger, blowing at the rate of 20 or 30 metres per second at an altitude of 10,000 metres, as shown by pilot balloons and telescopes. But the winds were very irregular; the westerly component was the most powerful, and winds from the south were as frequent as winds from the north. It will be seen from this most important exploration of the upper atmosphere within the Arctic circle—the results of which were communicated to the French Academy of Sciences—that the winds from the south are purely local, and that, if any strong winds predominate at all, it is those from westerly points.

During the months of July to September, 1908, an aërological expedition to Tropical East Africa was carried out by the Royal Prussian Aëronautical Observatory, Lindenberg, Germany, of which Dr. Richard Assmann, honorary member of the Royal Meteorological Society, is Director.

The object of the expedition was the exploration of the upper air in the heart of a tropical continent, in the very middle of the Equatorial belt. It was intended also to contribute to the elucidation of a well-known important problem—the origin and interior structure of the monsoon winds of the Indian Ocean—the influence of which on precipitation in India and the subsequent crops is of the highest and most practical interest.

The expedition left Europe in the middle of June, and arrived, viâ the Uganda Railway and the Victoria Nyanza, on July 24, at Shirati, in German East Africa, a town situated on the east coast of that vast lake in  $1^{\circ} 7'$  S. latitude. The members of the expedition were Professor Berson, director; Dr. Elias, formerly assistant at the Royal Aëronautical Observatory; and Mr. Mund, balloon superintendent of that Observatory.

In the interval between the end of July and the middle of September twenty-three ascents of self-registering balloons were made on the lake; fifteen of the balloons were recovered with their apparatus. In the two highest ascents of these balloons—namely

to 65,000 feet (19,800 metres) and 56,000 feet (17,000 metres)—the upper isothermal layer was duly found. It is, therefore, now proved to exist in the actual Equatorial belt, as it does over the Arctic Seas. The lowest temperature encountered at 65,000 feet was  $-119^{\circ}$  F. ( $-84^{\circ}$  C.), when the thermometer on the ground (3,800 feet=1,150 metres above sea-level) read  $79^{\circ}$  F. ( $26^{\circ}$  C.). The variability of temperature at high altitudes was very marked: in two subsequent ascents at 56,000 feet  $-105^{\circ}$  F. ( $-76^{\circ}$  C.) and  $-62^{\circ}$  F. ( $-52^{\circ}$  C.) were registered, while the whole annual variation on the ground does not exceed  $3^{\circ}$  or  $4^{\circ}$  C.

Besides these ascents of registering balloons, a large number of smaller pilot balloons, carrying no apparatus, were sent up, soaring in some instances to enormous heights, in order to complete a study of the wind. Their flight was observed with theodolites from fixed points on the shore. The most surprising result was the discovery of an uppermost current of air blowing nearly from due west, and flowing above the regular *easterly* current of the Equatorial region.<sup>1</sup> In a note by E. Gold he points out that according to Oberbeck's theoretical solution of the problem of the general circulation, the belt of easterly currents gets rapidly narrower with increase of height, and at very great heights the current will be westerly even close to the Equator.

The name of Léon Teisserenc de Bort is so intimately associated with the investigation of the upper air that it is allowable to cull the following facts relative to his life from the Minutes of the Council Meeting of the Royal Meteorological Society of October 16, 1907, at which meeting it was resolved that the Symons Memorial Gold Medal for 1908 should be awarded to him "for distinguished work done in connection with meteorological science."

Léon Teisserenc de Bort commenced his scientific work in 1878 as a member of the staff of the Bureau Central Météorologique de France. From 1880 to 1892 he was chief of the department of General Meteorology. He resigned his appointment in 1892 in order to devote himself to experimental research in meteorology. In 1896 he founded an observatory for the study of dynamical meteorology at Trappes, which has become famous for the bold-

<sup>1</sup> Dr. Assmann contributed a full descriptive account of this notable expedition to the Royal Meteorological Society on January 31, 1909 (*Quarterly Journal of the Society*, vol. xxxv., No. 149, p. 51).

ness of its enterprise and the success of its methods in the study of the upper air.

M. Teisserenc de Bort has also organised and directed for special purposes in connection with that study schemes for exploration of the upper air in Denmark and Lapland, on the Cattegat, and the Zuyder Zee. He has transformed a Hull fish-carrier into a floating meteorological observatory, which, under the name of the yacht *Otaria*, has carried out—partly with the assistance of Professor Rotch—extensive researches in the Mediterranean and over the intertropical belt of the Atlantic Ocean.

But M. Teisserenc de Bort is best known for his work upon the upper air by means of *ballons-sondes* and kites. The equipment used was designed and constructed at Trappes, and the results obtained have added largely to our knowledge of the upper air. The establishment of the existence of the so-called isothermal layer at a height of about 10 kilometres is largely due to the work of the Observatory. The identification of the return anti-trade above the north-east trade-wind; the structure of the intervening layer; and the comparison of the temperatures in the highest layers in various latitudes, which apparently show a gradient of temperature from the pole to the Equator, instead of one, as might be expected, in the opposite direction, are scientific achievements of M. Teisserenc de Bort, in collaboration, as regards some parts of the work, with colleagues of various countries.

With Professor Hildebrandsson, M. Teisserenc de Bort has recently completed an historical treatise on dynamical meteorology. The advances made in that subject by his personal exertions and at his own charges must always remain for future historians among the most original achievements of the present generation.

One of M. Teisserenc de Bort's most recent researches has been on the composition of air at great altitudes, with special reference to argon and its allies.<sup>1</sup> The collecting vessel was a glass tube with a finely drawn-out end, which was sealed after a very perfect vacuum had been made inside. When the tip of the capillary tube was broken at the desired height, the air was expected to enter readily and fill the tube, so that it only remained to fuse the capillary tip in order to secure the sample. The tube is opened by

<sup>1</sup> *Quarterly Journal of the Royal Meteorological Society*, July, 1908, vol. xxxiv., No. 147, p. 189.

the tip being broken off by the fall of a little hammer, released by an electric contact, and it is sealed by another contact allowing the current from a small accumulator to raise to red-heat a platinum wire wound round the capillary tube, by which means heat is produced sufficient to melt the glass. Both contacts can be made either by the barometer at a pressure previously arranged, or by the clockwork of the meteorograph, and the whole operation is so conducted that no impurity can possibly affect the air in the tube, the apparatus being hung at such a distance below the balloon (*ballon-sonde*) that there can be no trace of hydrogen in the air.

The apparatus, as first made on a very small scale, secured several little tubes of air in July, 1907. The quantity of air collected was too small to permit of an ordinary chemical analysis, and M. Teisserenc de Bort decided to confine himself to spectrum analysis, paying special attention to argon, neon, and helium. He proceeded by two different methods—one, by absorbing all the elements of the air, except helium and neon, by means of carbon; the other, by first separating the argon.

The result of the first experiment proved the presence of argon in all the samples of air taken between 8,000 and 14,000 metres (5 to 8 miles), as one would expect. Helium, distinguished by its yellow line in the spectrum, was detected in most of the specimens; but the highest of all, that taken at 14,000 metres, showed no trace of it. Neon was clearly discernible in every case. The attempts to disclose krypton have not as yet given any result, but the experiments on this gas have not been sufficiently numerous to allow an opinion to be formed on the subject (Paris, June 16, 1908).

From the commencement of 1909 the results of observations in the Upper Air have been stated by the Meteorological Office and other scientific bodies in absolute or metric units. The units adopted for each element are as follow: Altitude—Metres (m.) or kilometres (km.). Wind Direction—Angular Measures from North ( $360^\circ$ ) through East ( $90^\circ$ ). Wind Velocity—Metres per second (m.p.s.). Pressure—Megadynes per Square Centimetre (m.g.d.). Temperature—The Absolute Scale of Centigrade Degrees (freezing-point of water =  $273^\circ$ ; normal boiling-point of water =  $373^\circ$ ). Values at or below the freezing-point of water ( $273^\circ$ ) are printed in heavy type.



Tables for converting from British units to absolute or metric units are given in the Introduction to the Weekly Weather Report of the Meteorological Office for 1909, pp. 6, 7.

The explanation of the metric units is as follows: In order to avoid negative values, the temperatures are given in Centigrade degrees from the "absolute zero"—or, more strictly speaking, from  $273^{\circ}$  below the freezing-point of water—and in recording the air-pressure for different points of the ascents the unit of one megadyne per square centimetre, or 1,000,000 absolute c.g.s. (centimetre-gramme-second) units of pressure, are employed, because the megadyne represents practically the normal surface pressure at the level of the observing-stations; and, consequently, the pressure figures in megadynes per square centimetre (m.g.d.) give the fraction of pressure of the atmosphere which is still above the instrument. Thus, an entry in the pressure column of  $\cdot 527$  m.g.d. means that the instrument was at a point where the atmospheric pressure was reduced approximately to  $\cdot 527$  of the surface value. It is noteworthy that the conversion from millimetres of mercury (in latitude  $45^{\circ}$ ) to m.g.d. can be carried out with an accuracy of  $\cdot 1$  millimetre by adding one-third and moving the decimal point, and that a megadyne per square centimetre exceeds the kilogramme per square centimetre by less than 2 per cent.

In expressing the results of temperature measurements, the figure in the "hundreds" place is omitted. Thus, the freezing-point of water =  $32^{\circ}$  F. =  $0^{\circ}$  C. =  $73^{\circ}$  A. (*i.e.*, absolute temperature  $273^{\circ}$ ).

The vertical gradient of temperature is expressed in degrees C. per kilometre, and is reckoned positive when temperature diminishes with increasing height.

The most recent contributions to the investigation of the upper air are comprised in a report by Mr. W. H. Dines, B.A., F.R.S., on apparatus and methods in use at Pyrton Hill, Oxfordshire, with an introduction and a note on the "Perturbations of the Stratosphere," by W. N. Shaw, Sc.D., F.R.S., Director of the Meteorological Office, London.<sup>1</sup> At p. 13 of this monograph, which has only just been published, will be found a very full bibliography of the subject.

<sup>1</sup> *The Free Atmosphere in the Region of the British Isles*, Meteorological Office Publications, No. 202, 1909. Folio.

## PART III.—CLIMATE AND WEATHER

### CHAPTER XXIII

#### CLIMATE

IN his work on *Elementary Meteorology*, Dr. R. H. Scott, F.R.S., observes<sup>1</sup> that the old division of the world by Parmenides<sup>2</sup> into five zones—a central torrid zone, northern and southern temperate and frigid zones—has been found to be quite inadequate as a representation of the climatology of the globe.

In its original and stricter etymological sense, the word *climate* (Greek, κλίμα, *a slope* or *inclination*) was applied to one of a series of regions or zones of the earth running parallel to the Equator, from which the earth's surface was supposed to slope to the poles; hence the Latin rendering of κλίμα, *inclinatio cæli*.

According to this view, put forward by Claudius Ptolemy, the author of the *Ptolemaic System of the Universe* (A.D. 120-149), climate was determined solely by latitude, and one climate differed from another only as regards the relative length of the midsummer day and the relative altitude of the noontide sun. As a matter of fact, latitude is only one, and that, as we shall see presently, by no means the most important, factor in the determination of climate.

We may define climate as the condition of a country, district, or place, in relation to certain meteorological elements—notably air temperature, atmospheric pressure and wind, atmospheric moisture and electricity—viewed more particularly in their effects upon animal or vegetable life. It is these effects which determine the distribution of a fauna or of a flora in a given

<sup>1</sup> At p. 338.

<sup>2</sup> Of Elis. Flourished circa 430 B.C.

region of the globe. Dr. Scott points out<sup>1</sup> that the distribution of the plants of most importance to mankind, such as the cereals, depends chiefly on the summer temperature, while the distribution of animals is more dependent on the winter temperature. For example, the province of Manitoba in Canada yields magnificent crops of wheat, although its winter temperature often falls far below zero of the Fahrenheit scale. Maize, again, succeeds well in extreme climates, the summer season alone being sufficient for its whole life. On the other hand, plants which, so to speak, are *alive throughout the year*, like the fuchsia, the laurel, or even the hawthorn, would perish in the bitter winter of the "Canadian North-West," although they flourish in climates like that of the British Islands, where the fate of the wheat crop trembles yearly in the balance, and where maize entirely fails to grow.

In connection with this topic, attention has already been drawn to the estimation of accumulated temperature, or warmth available for agricultural purposes, expressed in "day-degrees" (see Chapter IV., p. 36). It may be well to repeat that a "day-degree" signifies 1° F. continued for twenty-four hours, or any other number of degrees for an inversely proportional number of hours, the term "accumulated temperature" indicating the combined amount and duration of an excess or defect of temperature above or below 42° F. for the period named.

Animals can bear a greater range of temperature than plants, and so their territorial distribution is more extensive than that of individual members of the vegetable kingdom. As Dr. Scott puts it, "The distribution of animals is more dependent on the winter temperature."

Climate depends chiefly on (1) distance from the Equator, or latitude; (2) physical configuration of the surface; (3) elevation; (4) nearness, or otherwise, of oceans; (5) prevailing winds. In his Lumleian Lectures on "Aëro-therapeutics in Lung Disease," delivered before the Royal College of Physicians of London in 1893, Dr. C. Theodore Williams, M.A., F.R.C.P., gives the principal factors of climate as follows:

1. *Latitude*—Naturally the greatest influence as describing the position of the sun towards the earth in a certain

<sup>1</sup> *Elementary Meteorology*, p. 338. 1883.

region, and thus determining the length and intensity of sunshine.

2. *Altitude*—By which the effects of latitude may be to some extent neutralised, for even in the tropics, at a height of 16,000 feet, snow and ice may exist, the temperature falling in ascending mountains  $1^{\circ}$  F. for every 300 feet.
3. *Relative Distribution of Land and Water*, and especially the presence of vast tracts of either desert or ocean; the former accentuating extremes of temperature, and the latter tempering them.
4. *Presence of Ocean Currents*, flowing from higher or lower latitudes (as the case may be), and thereby qualifying the climate.
5. *Proximity of Mountain Ranges*, and their influence on the shelter from wind and on the rainfall.
6. *Soil*—Its permeability or impermeability to moisture.
7. *Vegetation*.
8. *Rainfall*—Its amount and annual distribution.
9. *Prevailing Winds*.

It will be necessary to consider these factors in more detail.

I. *Latitude*.—A writer in *Chambers's Encyclopædia* (Art. "Climate") says: "The effect of the sun's rays is greatest where

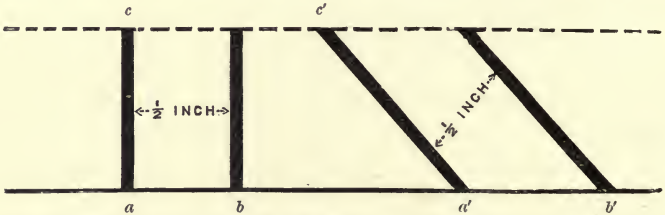

FIG. 94.—DIAGRAM ILLUSTRATING THE EFFECT OF THE PERPENDICULAR AND THE OBLIQUE FALLING OF THE SUN'S RAYS.

they fall perpendicularly on the surface of the earth, and diminishes as their obliquity increases; the surface which receives any given amount of the sun's rays increasing with their increased obliquity, as  $a'b'$  is greater than  $ab$  in the annexed figure; whilst, at the same time, the oblique rays being subjected to the influence of a greater number of particles of the atmosphere, as  $c'a'$  is longer than  $ca$ , a greater amount of their heat is absorbed before



they reach the surface of the earth at all. The greater or smaller extent of surface receiving a certain amount of heat, also makes important differences to arise from *exposure* by slope towards the Equator or towards the nearer pole."

II. *Altitude*.—It has been already shown (see Chapter IX., p. 99 *et seq.*) that temperature decreases with increasing elevation above sea-level, and that this is largely due to diminishing density of the atmosphere, as well as to reduced humidity. Even on the Equator perpetual snow and ice are found above a certain height, and Quito, the capital of Ecuador, at an altitude of 9,451 feet, enjoys an eternal spring, the mean temperature of the whole year and of every season being steady at 60° F.

The fall of temperature with altitude is not, however, uniform at all places having the same latitude. A striking example of this is met with in the climates of the Himalayan mountains. On the southern slopes of this vast and gigantic chain the snow-line, or limit of perpetual snow, is depressed by the precipitation of large quantities of snow and rain from the moisture-laden south-west winds coming from the Indian Ocean. These winds, first chilled and deprived of their moisture, but afterwards warmed by the latent heat set free in the condensation of their vapour into rain or snow, cross the summits of the Himalayan peaks and descend towards the plains of Central Asia. Being abnormally dry, these winds have an immense capacity for both heat and moisture, and so, as they descend, they become rapidly still warmer, and at the same time lick up both water and snow. The result is that the snow-line on the northern slopes of the Himalayas is at least 4,000 feet higher than it is on the southern side. Strictly analogous phenomena attend the passage of a south wind across the Alps, where it is called the *Föhn*; of a south-east wind across the mountainous interior of Greenland, bringing with it comparative warmth to North Greenland and Smith Sound; of the "Chinook" wind of the Rocky Mountains in Western Canada; and of a "nor'-wester" across the mountains of New Zealand. This last wind, taking its origin in the South Pacific, deposits its moisture on the western slopes of the New Zealand Alps, and appears in the Province of Canterbury on the east coast as a *very dry, and often a hot, wind, unaccompanied with rain.*

It is said that, when the Föhn is blowing in the Alps, the snow melts with marvellous rapidity, so that it is popularly called the "snow-devourer" (*Schneefresser*).<sup>1</sup>

III. *Relative Distribution of Land and Water*.—In our study of climate we may lay down as aphorisms—

*First*. That hot air is lighter than cold air.

*Secondly*. That the rapidity with which the processes of heating and cooling of air goes on is in direct proportion to the amount of aqueous vapour contained in that air—dry air becoming heated or cooled more rapidly and more completely than moist air, other conditions being alike.

*Thirdly*. That, consequently, the air over large areas of land, being drier, becomes more rapidly heated in summer and more rapidly cooled in winter than air which is in contact with extensive water-surfaces; and

*Fourthly*. That the radiation-heating power of dry land is greater than that of water, as also the radiation-cooling power of dry land is greater than that of water.

This group of facts is of paramount importance in climatology. The effect of them upon the climate of the great continent of Europe and Asia has already been described in Chapter XIII. (see p. 156).

We can, indeed, form but little idea of the enormous changes of temperature which take place in Central and Northern Asia between the seasons of summer and winter. But that these changes are sufficient to produce the great variation in barometrical pressure on which depends the varying wind-system of the continents of Europe and Asia in those seasons may be easily shown by a comparison of the range of temperature between July and January in an insular<sup>2</sup> climate like our own, and at Yakutsk, in Siberia, which is situated close to the centre of lowest and highest barometrical pressures in those months respectively. At Dublin the mean temperature of July is about

<sup>1</sup> For a full account of the Swiss Föhn wind, see a paper by Dr. Wild, the Director of the Imperial Observatory at St. Petersburg, *Ueber Föhn und Eiszeit*. Bern, 1868.

<sup>2</sup> The terms *Insular* and *Con'inen'al*, as applied to climate, usually signify merely that it is characterised by a small or by an extreme range of temperature respectively, without any reference to the geographical position of a place as regards the seaboard.

60° F., of January about 40° F.—a range of only 20°. The corresponding mean temperatures at Yakutsk are 66° F. and -45° F. respectively—a range of 111°. For weeks in summer the thermometer ranges between 80° and 90° at this place, while in winter it may descend 90° below the freezing-point of water. Well does Humboldt observe :<sup>1</sup>

“The inhabitants of the countries where such *continental climates* prevail seemed doomed, like the unfortunates in Dante’s *Purgatory*—

“ ‘ A soffrir tormenti caldi e geli.’ ”

Or, as Milton has so admirably expressed it—

“From beds of raging fire to starve in ice.”

“The capability of man to endure variations and extremes of temperature,” says Dr. Theodore Williams, “has been proved to be very great, for General Greely states that at Fort Conger, U.S.A., in February, 1882, he experienced the low temperature of -66·2° F., and at another time, in the Maricopa Desert, Arizona, he saw noted the air temperature of 114° F., while the metal of his aneroid beside him as he rode assumed a temperature of 144° F.”

The lowest mean monthly temperature ever recorded is -88·8° F. (-67·1° C.) at Werchojansk (or Verkhoyansk), in Siberia, lat. 67·5° north, in January, 1886. This cold station lies in the valley of the River Jana, 330 to 460 feet above sea-level. At Poplar River, Montana, North America, the thermometer fell to -63·1° in January, 1885.

The principal laws of distribution of annual range of temperature, given by Professor A. Supan in a paper which appeared in the first volume of Kettler’s *Zeitschrift für wissenschaftliche Geographie*, are thus summarised by Dr. R. H. Scott :

1. The annual range of temperature increases from the Equator towards the poles, and from the coast towards the interior of a continent. It is greatest—100° F. and upwards—in Siberia, near Yakutsk. It is least—under 20° F.—over almost the whole of the sea surface of the globe, in South America and South Africa.

<sup>1</sup> *Kosmos*, vol. i., p. 352.

2. The regions of extreme range in the northern hemisphere coincide approximately with the districts of lowest temperature in winter. On the whole, the range curves in their course resemble the isotherms of January.

3. The range is greater in the northern than in the southern hemisphere.

4. In the middle and higher latitudes of both hemispheres, with the exception of Greenland and Patagonia, the western coasts have a less range than the eastern.

5. In the interior of the continents the range, in mountainous districts, diminishes with the height above the sea.

Probably nowhere is the influence of the ocean in restricting the annual range of temperature more marked than off the extreme south-west coast of England. In the Scilly Isles the mean temperature of the sea surface ranges between  $49^{\circ}$  in February and  $61^{\circ}$  in August—that is, through  $12^{\circ}$ . The mean temperature of the air is  $46.3^{\circ}$  in January and  $61.5^{\circ}$  in July—a mean annual range of only  $15.2^{\circ}$ . At Yarmouth, also *on* the sea, but not *in* the ocean, the temperature of the sea surface ranges from  $37^{\circ}$  in January to  $61^{\circ}$  in July—the mean temperature of the air being  $37.9^{\circ}$  and  $62.5^{\circ}$  in the months named—a mean annual range of  $24.6^{\circ}$ .

Perhaps no single element has a greater influence upon climate than the presence of water. Its specific heat<sup>1</sup> is four times that of dry land, and consequently it absorbs heat more slowly, stores up a larger amount of it, and parts with it less rapidly. Again, owing to condensation by cold, surface water, when exposed to low temperatures, sinks, and its place is taken by the deeper strata of warmer liquid. Equilibrium of temperature is thus maintained in the neighbourhood of extensive areas of water. In warm weather evaporation from water surfaces tends to cool the superincumbent air, to increase the humidity, and to fill the atmosphere with clouds. Hence the equable, cloudy, and moist climates of seaboards. Extensive lakes produce similar effects on a smaller scale. Thus, in the Canadian winter, what may be a storm of rain on the shores of Lake Superior

<sup>1</sup> The *specific heat* of a substance is the number of units of heat required to raise the temperature of 1 pound of it by  $1^{\circ}$ .



is often a fall of snow a few miles inland. When districts of country are partly covered with water, the climate is rendered damp and cool, for the evaporation from wet earth is much greater than that from a uniform water surface. Under such circumstances there is reason to believe that a climate would even be improved by changing marshes or morasses into sheets of open water. Like good results often follow the carrying out of effective drainage works, and there can be no doubt that, if the water-shed of the Shannon, for example, were properly drained, the climate of the whole of Ireland would be made drier and warmer. This is a subject of vital importance to all who have agricultural interests in view, as well as to those who have regard to the public health.

In estimating the effect of water surfaces upon climate it should not be forgotten that, while fresh water attains its maximal density at  $39\cdot2^{\circ}$  F., and freezes at  $32\cdot0^{\circ}$  F., sea water continues to contract until it is chilled down to  $26\cdot2^{\circ}$  F., and does not freeze above  $28\cdot4^{\circ}$  F. The result is that sea water in the open will not begin to freeze on its surface until all its depths have been cooled nearly to freezing-point, whereas fresh water needs to be chilled throughout only to  $39\cdot2^{\circ}$  F. before ice commences to form on its surface.

Turning to the question of the influence of dry land on climate, we find that the *configuration of the surface* of the ground exercises an effect second only to that of the *amount* of land. Thus, as a rule, when the surface slopes away from the sun, the rigour of the climate is intensified. We have especially striking examples of this in North Germany, Siberia, and those parts of North America which slope towards Hudson Bay. The converse is also true, and is exemplified in the excessive summer heat of Northern Italy, India, and Southern China. Most winter resorts are situated on grounds having a southern, or solar, aspect. But, leaving out of consideration the *direct* influence of the presence or absence of the sun's rays, the cooling of the air by terrestrial radiation is found to affect localities in very different degrees. Where the surface is uniformly level, as in the case of plains or table-lands, radiation proceeds uniformly, and the whole district is equally chilled. If the air is calm and the sky clear, radiation

goes on rapidly, and the temperature falls. Should the sky be clouded and the air in motion, radiation is uniformly checked. The alternations in either case are similar over the whole area of level ground. In hilly or mountainous districts radiation acts as before, but the air which is cooled becomes specifically heavier, and immediately commences to flow down the mountain sides. As it is replaced by warmer air, the temperature remains comparatively high and uniform. On high ground, also, the atmosphere is seldom calm, so that radiation is usually more or less checked, and warmth is maintained. Valleys, however, experience extreme variations of temperature for two reasons—first, because the cooled air flows down into them from the surrounding high grounds; and, secondly, because, being so much shut in, they are fully exposed in the absence of wind to the influence of radiation.

Great diurnal range of temperature is a marked feature in inland districts, particularly when the earth's surface is desert or scantily dotted with vegetation. Thus at Mooltan (where the thermometer ranges yearly from  $29^{\circ}$  to  $126^{\circ}$  F. in the shade), Rawal Pindi, and other stations in the Punjâb, the daily range in April and November may amount to  $40^{\circ}$  F. The same state of things is observed in Egypt, on the steppes of Southern Russia, and on the prairies of North America. Even in the British Islands in anticyclonic weather, with a dry atmosphere and easterly wind in spring, a large diurnal range of temperature is often noticed. For example, at Nairn, in the north-east of Scotland, the thermometer rose to  $72^{\circ}$  F. in the screen on May 5, 1909, but fell to  $32^{\circ}$  F. in the course of the following night. On Good Friday, April 17, 1908, Mr. Sydney Wilson recorded at Perth a range of  $40\cdot2^{\circ}$  F. in a few hours. About 6 a.m. of that day a minimum reading of  $27\cdot8^{\circ}$  F. occurred, whereas about 2 p.m. the thermometer had risen to a maximum of  $68^{\circ}$  F.

A third instance of extreme diurnal range of temperature may be given. At Marlborough, Wiltshire, during the great heat-wave of 1906, the thermometer rose on August 30 from a minimum of  $37\cdot1^{\circ}$  F. in the early morning to a maximum of  $83\cdot6^{\circ}$  F. some twelve hours later—a swing of  $46\cdot5^{\circ}$ .

IV. *Ocean Currents* of either warm or cold water modify climate in a remarkable degree. They are named according to

the direction *towards which they flow*. The ameliorating effects of the presence of a vast water-surface are intensified in the case of oceans, such as the Pacific and Atlantic, in winter-time, by the setting towards the Arctic and Antarctic regions of immense surface-currents of warm water. The best known of these currents is the North Atlantic surface drift, commonly, but not quite correctly, called the "Gulf Stream," which flows north-eastward along the western shores of the British Isles and Norway, and to which we are so largely indebted for our wonderfully mild British winters.

"Its climatic effect," says Mr. J. Knox Laughton, M.A.,<sup>1</sup> "when stated in measures of heat, is stupendous—it is the very poetry and romance of arithmetic." He proceeds to show that the heat brought by the Gulf Stream into the North Atlantic has been fairly estimated as not less than one-fifth of the whole heat possessed by the surface water of that division of the ocean. Assuming, with Sir John Herschel, that the temperature of space is 239° F. below zero, and taking the existing temperature of the North Atlantic as 56° F. above zero, we find that the heat which it actually has corresponds to a temperature of 295° F. (namely, 239° + 56° F.), the fifth part of which is 59° F. If, then, the fifth part of its heat—that is, the heat derived from the Gulf Stream—were taken away from it, the surface water of the North Atlantic would have an average temperature of -3° F., or 35° F. below the freezing-point of fresh water.<sup>2</sup> It is roughly estimated that about five billions of cubic feet of water are hourly poured through the Straits of Florida into the North Atlantic. This water has at the time an average temperature of not less than 65° F., but after performing a circuit in the North Atlantic, it returns to the Tropics as an undercurrent with an average temperature not above 40° F. It has imparted to the air over the North Atlantic the heat corresponding to a difference in temperature amounting to 25° F. Now, the British standard measure of heat—the *thermal unit*—is the quantity of heat required to raise the temperature of 1 pound of water by 1° F., while a cubic foot of water weighs about 64 pounds. With these data, we find that the heat

<sup>1</sup> In a lecture on "Air Temperature: its Distribution and Range." *Modern Meteorology*. Edward Stanford. 1879.

<sup>2</sup> Croll's *Climate and Time*, p. 35 *et seq.*

thrown out by the Gulf Stream every hour into the air of the North Atlantic is  $25 \times 64 \times 5,000,000,000,000$  thermal units.

But every thermal unit, according to the "Law of Equivalence," experimentally established by Dr. Joule, of Manchester, is capable of lifting a weight of 772 pounds through a height of 1 foot. Consequently, the heat hourly dispersed from the water of the Gulf Stream, if stored up and applied as power, would be capable of lifting each hour  $772 \times 25 \times 64 \times 5,000,000,000,000$  pounds through a height of 1 foot—that is, of doing the work of steam-engines having an aggregate horse-power of 3,119,000,000,000, a power equal to that of nearly 400,000,000 ships such as our largest ironclads.<sup>1</sup>

Ocean currents of *cold* water also exist. Of these the most notable, probably, is that which flows out of Baffin's Bay down the eastern shores of North America, and which is known as the American Arctic Current. Its cooling influence is felt as far south as Cape Cod, in latitude  $42^\circ$ .

On Friday, August 13, 1909, I left Liverpool for Quebec as a passenger on board the Royal Mail Steamer *Empress of Ireland*, of the Canadian Pacific Railway's Atlantic Service. Her commander was Captain J. V. Forster, R.N. Reserve, who courteously placed at the disposal of the passengers full information relating to the ship's "log." This included observations on the state of the barometer, the temperature of the air and of the sea, the direction and force of the wind, made at the various four-hourly "watches," besides the usual noontide record of the distance run in knots and the latitude and longitude of the ship's meridian position. From 8 a.m. on Saturday, August 16, till the afternoon of the following day, the sea-temperature remained steady at about  $56^\circ$  F. From the afternoon of Sunday, the 17th, until 4 p.m. on Monday, the sea-water ranged from  $54^\circ$  to  $49^\circ$  F. The position of the ship at the latter hour was approximately  $55^\circ$  N. latitude,  $40^\circ$  W. longitude. Four hours later—at 8 p.m. of the 16th—the temperature of the sea was only  $38^\circ$  F., a fall of  $11^\circ$  in four hours. In the course of the next afternoon—Tuesday, the 17th—several icebergs were sighted, two of unusual size. The mathematicians on board calculated that one berg to the

<sup>1</sup> Croll's *Climate and Time*, p. 25.



northward was distant seven miles on the beam N.N.W., was 220 feet high, and 900 feet long. At noon on this day the sea-temperature was 40° F.; by 8 p.m. it had fallen to 33° F. At 10.30 p.m. the lights of the Strait of Belleisle were sighted. It was quite evident that the ship had passed on the afternoon of the 16th from the warm north-easterly surface drift current into the chill waters of the American Arctic current, setting south from the west and east coasts of Greenland past the inhospitable shores of Labrador. The "Pilot Chart" for September, 1909, of the North Atlantic Ocean, issued by the Hydrographic Office, Washington, D.C., shows that icebergs in large numbers were reported during August in and near the Strait of Belleisle, and in smaller numbers on the Grand Banks. From August 10 to 13 the Strait was full of bergs, the British s.s. *Montfort* sighting seventy-nine, and the British s.s. *Hesperian* eighty-five, of which twenty-two were west of Greenlet Island, Newfoundland. On August 2, Captain Best, of the British s.s. *Shimosa*, reported a piece of ice, 18 feet long and 5 feet wide, in latitude 37° 16' N., longitude 42° 06' W.

An Arctic current of far less magnitude flows into the North Pacific through Behring's Straits. It chills the air over Kamchatka and Japan in the summer season, throwing the isotherms over the North Pacific into remarkable loops in July, when the current is strongest owing to the melting of the polar ice. In the southern hemisphere the oceanic polar currents form a still more striking feature in the physical geography. According to Sir F. Evans,<sup>1</sup> all the surface water between the Antarctic Circle and the parallel of 45° S. seems to drift northwards and eastwards, causing the isotherms on the western coasts of America, Africa, and Australia to dip down towards the Equator (R. H. Scott). The best-known of these currents is the Peruvian, or Humboldt's current, which washes the west coast of South America. Dr. Scott also points out that the influence of the Antarctic Atlantic current on the west coast of Africa is such that the temperature of the sea near Cape Town is sometimes 20° F. lower than in the corresponding latitude on the eastern side of the continent.

<sup>1</sup> *British Association Report*, p. 175. 1876.

## CHAPTER XXIV

### CLIMATE (*continued*)

V. *Proximity of Mountain Ranges*.—Dr. Alex. Buchan, in his *Introductory Textbook of Meteorology*,<sup>1</sup> stated that, apart from diverting the winds from their course, the chief effect which mountain ranges have upon the temperature (and so upon climate) is to drain the winds which cross them of their moisture. Colder winters and hotter summers in places to the leeward, as compared with places to the windward, are thus caused ; for the protecting screen of aqueous vapour is partially removed by condensation, and so the country to the leeward of a mountain chain becomes more fully exposed to both solar and terrestrial radiation. For the same reason, the rainfall is lessened in such sheltered localities, although it is, of course, proportionately increased on the windward side of the mountains. Dr. Theodore Williams cites the extraordinarily dry climate of Colorado, which lies under the lee of the Rocky Mountains, as an instance of the influence of a mountain-range on climate. Nearer home we have similar examples on a much smaller scale in several parts of the British Isles : heavy and continuous rainfalls in the mountainous districts of Kerry, Cumberland, and the west of Scotland, contrasting with comparatively dry climates in Dublin, the Lowlands of Scotland, and the coasts of the Moray Firth, Nairnshire, and the Carse of Sutherland. These last-named districts, according to Dr. Scott, owe their good fortune mainly to the fact of their lying on the lee-side of an extensive mountain district. As regards Dublin, a range of mountains lies a few miles south of the city, with summits varying in height from 1,000 to more than 2,500 feet. This mountain chain intercepts the vapour-laden

<sup>1</sup> William Blackwood and Sons : Edinburgh and London. 1871. P. 73.

winds at all points between south-south-east and south-west. In consequence, the rainfall is diminished and the sky is comparatively cleared during the continuance of the southerly and south-westerly winds which so frequently prevail. Dublin and its neighbourhood are the only part of Ireland where the annual rainfall falls short of 30 inches—it is about 28 inches—and this depends on the geographical situation of the city on the east coast and to the leeward of high lands, grouped into mountains to the south-east, south, and south-west, whereby the rain-bearing winds are drained of their superabundant moisture before they reach the valley of the Liffey and the plains lying north of that river. This relatively dry region stretches along the east coast northwards to Dundalk Bay.

It is everywhere recognised at the present day that the chief cause of the condensation of the aqueous vapour of the atmosphere by a mountain chain is the adiabatic cooling of the rising mass of air, for a current of air impinging on high ground must, in order to pass over it, necessarily rise. A thoroughly scientific attempt to investigate the process of adiabatic cooling of ascending air currents quantitatively was made some years ago (in 1901) by Professor F. Pockels, of the School of Technology, Dresden, Germany. His memoir on the subject, entitled “The Theory of the Formation of Precipitation on Mountain Slopes,” appeared originally in *Annalen der Physik*, 1901.<sup>1</sup> A translation of the article will be found in the *Monthly Weather Review*, of the United States of America Department of Agriculture, for April, 1901.<sup>2</sup>

VI. *Soil*.—With regard to the absorbing power of heat possessed by soils, Schübler has arranged them in the following order,<sup>3</sup> 100 being assumed as the standard :

Sand with some lime, 100 ; pure sand, 95·6 ; light clay, 76·9 ; gypsum, 73·2 ; heavy clay, 71·11 ; clayey earth, 68·4 ; pure clay, 66·7 ; fine chalk, 61·8 ; humus,<sup>4</sup> 49. This list shows the high absorbing power of the sands, and the comparative coldness of

<sup>1</sup> Vol. iii., pp. 459-480.

<sup>2</sup> Vol. xxix., No. 4, pp. 152-159.

<sup>3</sup> Parkes's *Manual of Hygiene*, p. 312. Fourth edition.

<sup>4</sup> Humus is the organic matter of the soil, which is made up of the products of the decomposition of vegetable substances. These products may be arranged in three classes: (1) Those soluble in water—crenic, apocrenic, and ulmic acids; (2) those soluble in alkaline solutions, but not in pure water—humic and geic acids; (3) those insoluble—humin and ulmin.

the clays and humus. The absorbing power of water possessed by soils varies in a similar manner. Sands retain but little water, clays about ten to twenty times as much as sands, and humus double as much again. Clays and humus are comparatively unsuitable as sites for building, owing to their characters of coldness and dampness. In some diseases they are very injurious, as, for example, in phthisis, rheumatism, and catarrh. If damp soils be exposed to a high temperature, they may cause ill-health, owing to decomposition of the organic matter mixed with them. Marshy soils, alluvial soils, old estuaries, and deltas contain much organic matter, and should be regarded with suspicion. Peaty soils also are largely composed of organic matter, but they are not so injurious to health, owing probably to the preservative properties of peat. Granite, metamorphic and trap rocks, clay-slate, chalk, sandstone, gravels, and the pure sands, are healthy, and suited for building sites. The limestone and magnesian limestone rocks and mixed sands are only moderately healthy.<sup>1</sup>

Three diseases, leaving malaria and mosquitoes out of the question, appear to be intimately connected with the presence of water in the soil. In 1862 Dr. Bowditch, of Boston, U.S., drew attention to the relations between the prevalence of phthisis and the amount of sub-soil water. His researches were amply confirmed by Dr. (afterward Sir George) Buchanan,<sup>2</sup> who discovered that the death-rate from phthisis in various towns in England was greatly reduced in consequence of efficient drainage and removal of the sub-soil water. Many years ago Pettenkofer of Munich advanced the doctrine of the ultimate dependence of enteric fever and of cholera on the varying level of the sub-soil or "under-ground" water,<sup>3</sup> the most dangerous period, according to him, being that of the sinking of the water after a previous rise.

The high absorbent power of loose sandy soils is doubtless due to the presence of large quantities of imprisoned air, which converts the sand into a bad conductor of heat. Hence such soils heat readily in summer and cool readily in winter *near the*

<sup>1</sup> Cf. Parkes, *Manual of Hygiene*, p. 314 *et seq.*

<sup>2</sup> *Ninth and Tenth Reports of the Medical Officer of Health to the Privy Council.*

<sup>3</sup> *Zeitschrift für Biologie*, 1868.



surface ; but these extremes of temperature do not penetrate by conduction to any depth. Dr. Williams states<sup>1</sup> that the sandy soil in an Arabian or Egyptian desert may be heated to 120°, 140°, or even 200° F., and when the particles of this hot sand are carried through the air by the terrible simoom, the shade temperature may rise to 125° F. On the other hand, Dr. Buchan mentioned in his *Introductory Textbook of Meteorology*,<sup>2</sup> that in Scotland, for a period of nine years, the temperature at 3 inches below the surface fell to 26·5° F. in loose sandy soils, but at a depth of 12 inches the freezing-point was only once observed. In clay soils, at 3 inches the lowest temperature recorded was 28° F., whilst at 12 inches the temperature often fell to freezing, and even at 22 inches 32° F. was more than once recorded.

VII. *Vegetation*.—A district covered with a luxuriant growth of plants and forest trees has a comparatively uniform and temperate climate. By day the heat is lessened, because the vegetation intercepts a large proportion of the sun's rays, which would otherwise heat the earth's surface ; also, because the evaporation from leaves and grasses renders heat latent, and so keeps the atmosphere cool. By night radiation from the surface of the ground is checked, and so the fall of temperature is diminished. Forests control evaporation and increase the humidity of the air ; they are also said to increase the rainfall, but this seems not to be satisfactorily established. As moist air prevents excessive heat in summer and excessive cold in winter, forests are thus seen to be of use in mitigating extremes of climate. In winter they afford shelter from storms, and in tropical climates the spread of malaria is said to be prevented by the interposition of a belt of trees between a malarial swamp and a village. Sir Patrick Manson suggests, in explanation, that the trees may filter out the mosquitoes by affording them protection from winds, and so the houses on the leeward of the trees escape infection.<sup>3</sup>

The third number of *Petermann's Mittheilungen* for 1885 contained an article of exceptional interest by Herr A. Wojeikof on the influence of forests on climate. The first step towards a

<sup>1</sup> *Lum'ean Lectures*, 1893.

<sup>2</sup> P. 46. 1871.

<sup>3</sup> *Tropical Diseases*, p. 104. Fourth edition. By Sir Patrick Manson, K.C.M.G., M.D., LL.D.(Aberd.). London : Cassell and Co. 1907.

scientific investigation of this subject was taken when the Bavarian forest meteorological stations were established, and when Prussia, Alsace-Lorraine, France, Switzerland, and Italy followed the example. As a general rule, it may be laid down that during the warmer season, (1) the temperatures of the earth and air are lower in the forests than in contiguous woodless places ; (2) their variations are less ; (3) the relative humidity is greater. The influence of forests in diminishing evaporation from water and the soil is so great that it cannot be accounted for solely by the lower temperature of the warm months, the greater humidity, or even by the shade—the protection from the wind afforded by the trees is regarded by Herr Wojeikof as more important than all these factors together in reducing the amount of evaporation. With respect to the influence of forests on rainfall and snowfall, there is as yet only a single series of observations supplying comparative statistics, and extending over a sufficiently long period—namely, six years. These were taken in the neighbourhood of Nancy by the pupils of the School of Forestry of that city, under the direction of M. Mathieu, sub-director of the school. These observations, reported in *Polybiblion*, 1882, prove that—

1. Forests increase the quantity of meteoric waters which fall on the ground, and thus favour the growth of springs and of underground waters.

2. In a forest region the ground receives under cover of the trees as much water as, or more than, the uncovered ground of regions with little or no wood.

3. The cover of the trees of a forest diminishes to a large degree the evaporation of the water received by the ground, and thus contributes to the maintenance of the moisture of the latter, and to the regular flow of springs.

4. The temperature in a forest is much less variable than in the open, although, on the whole, it may be a little lower ; but the *minima* are there constantly higher, and the *maxima* constantly lower, than in regions not covered with wood.

M. Fautrat, when sub-inspector of forests at Senlis, made observations on forestal meteorology during four years. These, although conducted on a different method, fully corroborate

those of M. Mathieu in several respects. He adds the following interesting remarks: Rain falls most abundantly over forests with trees in full leaf; the humidity of the air is much higher over masses of *Pinus sylvestris* than over masses of leafed species; and the leafage and branches of leafed trees intercept one-third, and those of resinous trees one-half, of the rain water, which afterward returns to the atmosphere by evaporation.

The influence of forests on the dampness of the soil and on the yield of springs was discussed by Professor H. Gravelius in *Petermann's Mittheilungen* for March, 1901. The result of the Professor's study of the recent Russian literature on the subject is to show very clearly that forests do not preserve the moisture of the ground or promote the flow of springs. All the experiments showed that the level of ground water was lower under great forests than in open country, even in the Russian steppe. The forest appears to protect the ground altogether from light rains, which are absorbed by the foliage or evaporated from the immense surface formed by the leaves as the drops trickle downwards. Heavy rains reach the ground nearly as freely as in open land, but here the tree roots play their part, and the transpiration of the vegetation keeps the soil dry to a considerable depth. These facts go to prove the immense value of forests on mountain sides for checking floods, and of the planting of woods in swampy country as an aid to drainage in drying the land.<sup>1</sup>

Herr Wojeikof endeavoured to ascertain the influence of forests on the climatic conditions of their neighbourhood in the western parts of the Old World, between the 38th and 52nd degrees N. latitude, the places selected being in all cases in the open. Thus, for the 52nd degree, eight stations were taken between Valentia Island, in Ireland, on the west, and the Kirghiz steppe on the east; for the 50th, Guernsey on the west, Semipalatinsk on the east, and ten other intervening stations; and so on for each two degrees of latitude to 38° N. The general result of the observations at fifty stations in six different degrees of latitude is that in Western Europe and Asia large forests have a great effect upon the temperature of places near them. The

<sup>1</sup> *Symons's Meteorological Magazine*, vol. xxxvi., p. 116. 1901.

normal increase of temperature as we travel eastward from the Atlantic Ocean to the interior of the Continent is not merely interrupted by the influence of forests, but places far removed from the coast through that influence enjoy a cooler summer than those actually on the sea. A striking example of this is Bosnia, where the summer is  $4.5^{\circ}$  to  $8.1^{\circ}$  F. cooler than in Herzegovina. Bosnia, separated by lofty mountain ranges from the sea, has extensive forests; Herzegovina, on the contrary, is almost disafforested. Even on the Island of Lissa, where under the full influence of the Adriatic Sea the summer should be cooler, the temperature is more than  $1.8^{\circ}$  F. higher than it is in Bosnia. In Portugal, which is poor in forests, the temperature rises very rapidly towards the interior during the almost rainless summer. The heat is still greater in stony Attica, notwithstanding the proximity of the sea. On the eastern shore of the Caspian, owing to the desert of sand and stone, the summer temperature is extremely high, whereas at Lenkoran, on the western shore of that vast inland sea, a cool though dry summer is enjoyed. In the great Lenkoran forest vegetation is more luxuriant than in any part of Europe, for a tangled mass of climbing plants encircles the trees, so that it is always humid in the forest. Yet here the rain curve is a sub-tropical one—very little rain falling in the summer, but large quantities in autumn and winter. The water is stored up in the forest, so maintaining evaporation during the summer droughts.

“To sum up: Forests exercise an influence on climate which does not cease on their borders, but extends over a larger or smaller adjacent region, according to the size, kind, and position of forest. Hence man, by afforestation and disafforestation, can modify the climate around him; but it is an extreme position to hold that by afforestation the waste places of the earth can be made fertile. There are places incapable of being afforested, which would not give the necessary nourishment to trees” (*Nature*, vol. xxxii., 1885, p. 115).

Some thirteen years ago (February 15, 1897) the following query was addressed to me by a distinguished Medical Journalist: “Is it regarded as insanitary to have ivy and other evergreens clinging to walls of hospitals?” My reply was as follows:



An ivy-clad wall is a *dry* wall. Rain is intercepted when beating against such a wall, and the rootlets (or tendrils) of the ivy absorb all moisture from the mortar, bricks, and even stones, of which the wall is built.

An ivy-clad wall is a *warm* wall. Radiation of heat from the wall is interfered with, and temperature does not fall in cold weather under the shelter of the ivy within several degrees of the temperature of the open air.

Other evergreens produce similar effects, though in a less degree, owing to their inherent greater moisture and less close foliage, which is also less regular.

An ivy or evergreen covering has the disadvantage of harbouring insect life near windows and doors. In any case, such a covering should be periodically trimmed, so as not to interfere with the free access of both air and light to windows and doors.

VIII. *Rainfall*.—The influence of precipitation on climate has already been discussed at some length in Chapter XVIII. (pp. 221, 242, 261-263). In estimating it, regard should be had to the monthly, seasonal, and yearly rainfall, both in individual periods and on an average of many such periods. Equally important is it to know the number of "rain days" (or days upon which '005 inch of rain or upwards is measured in the gauge) which may be expected to occur in each month, season, or year. Nor should the probability of heavy or torrential rainfalls—1 inch or upwards—be left out of account. It is evident that a moderate rainfall spread over many days throughout the year may constitute a *wet* climate, while a still heavier rainfall restricted to a given season may characterise what is essentially a *dry* climate. Another element worthy of consideration is the frequency of thunderstorms, so often attended by torrential rains, and of hailstorms. Lastly, the seasonal limits of snowfall should be investigated, and the average and extreme duration of an unbroken snow-covering.

This last topic has been ably handled by Dr. Alexander Wojeikof in a paper on the "Influence of Accumulations of Snow on Climate," which was read before the Royal Meteorological Society, June 17, 1885.<sup>1</sup> It has already been shown in these

<sup>1</sup> *Quarterly Journal of the Royal Meteorological Society*, vol. xi., p. 299. 1885.

pages that snow is a bad conductor of heat, and accordingly protects the underlying soil from excessive cold. But much depends on the structure of the snow. If it consists of loosely piled small feathery flakes, which entangle air in large quantity, it is a thoroughly bad conductor, and so affords most protection. If, however, by alternate thawing and freezing, it solidifies into ice—assuming the form called in Germany *Firn*, and in France *névé*—it is a far better conductor of heat, and the underlying soil will quickly freeze.

Again, the air over a snow-covered surface will become extremely cold—first, because the snow cuts off from it the warmth of the ground, and, secondly, because dry feathery snow is a good radiator of heat. Then, as there is but little dust in the air over a snow-covered country upon which the solar rays can act, these rays will be unable by themselves to thaw a deep snow covering. How, then, is it that the winter snow *does* melt in the northern parts of Europe, Asia, and North America? Dr. Wojeikof has no doubt that the thaw is first caused by winds from warmer quarters, or from open oceans. These warm winds cause the upper layer of snow to melt. After it has been frozen again, it is changed to *névé*—that is, to a condition in which it is somewhat diathermanous to solar heat, and radiates heat much less freely. Once this happens, the melting of snow goes on much more easily. To a small extent the melting of the snow may be helped by dust brought by the winds from continental areas already free from snow. No doubt a great quantity of heat is expended on the melting of the snow, and so the warm winds are chilled, and lose their power of thawing the snow. But near the border of the snow-covered country, when the snow has mostly melted there, the surface of the ground can be heated by the sun, and thus become a source of heat for the country lying still farther to the northward. The melting of the snow is progressive from, say, February to June in the northern hemisphere. It begins close to seas which do not freeze, and continental areas which are not permanently covered with snow even in mid-winter. Thence it proceeds intermittently by leaps and bounds until all the lowlands of our hemisphere are freed from their snow-covering.

In high southern latitudes no such happy event takes place. Sir James Ross proved that the mean temperature of the shores of the Antarctic Continent, or the islands bound together by glacier ice, and so appearing like a continent, is much below the freezing-point even at midsummer. There is no notable melting of snow, and what is melted is very soon replaced by fresh snow. The geographical position explains this. The shores of the Antarctic Continent are washed by an ocean, the surface water of which has a temperature below freezing-point to about  $62^{\circ}$  S. even in summer, while they lie at a distance of  $20^{\circ}$  or more from any land area of lower latitude which could supply warmth for the thawing of their eternal snows. We see, then, that the sun's rays are of themselves unable to raise the temperature above freezing-point, notwithstanding the nearness of the sun to the earth in the summer of the southern hemisphere.

Mr. L. C. Bernacchi, Physicist to the National Antarctic Expedition of 1902-04, states that the mean temperature observed by Lieutenant C. W. R. Royds, R.N., at the winter quarters of the *Discovery*, in latitude  $77^{\circ} 50' 55''$  S., longitude  $166^{\circ} 55' 45''$  E., for the two years from February 9, 1902, to January 31, 1904, was  $-1.7^{\circ}$  F. The lowest mean temperature for any one month was  $-21.1^{\circ}$  F.—for July, 1903; and the highest mean temperature  $26.1^{\circ}$  F.—for January, 1903. The absolute maximal temperature observed in 1902 was  $39.0^{\circ}$  F., in December, and in 1903  $42.0^{\circ}$  F., also in December. The summers were very cold; only a few days gave a mean temperature above freezing. Mr. Bernacchi states that the large mass of land ice and the remarkable dryness of the air would seem to be partly responsible for this. The air, he adds, is very transparent, fogs are infrequent, and precipitation is slight. An outstanding feature is the abundance of bright sunshine in the summer. The total of 490 hours in December, 1903, is equal to 66 per cent. of the possible amount. On one occasion there was continuous sunshine for 87 hours. Solar radiation temperatures were very high, although the sun, when it attained its greatest altitude in December, was more than  $60^{\circ}$  from the zenith. The mean black bulb temperatures for December and January are only  $14^{\circ}$  F. less than the corresponding means (June and July)

at Madras, with an almost vertical sun. The maximal solar radiation reading came within 3° F. of the Madras maximum.

In our northern hemisphere the melting of the snow keeps the temperature for a long time near freezing-point. This is the reason why April is so much colder than October in Central European Russia, in Canada, and in the more northern of the United States. Hence also the keenness of the easterly winds of spring in Western Europe, even in the British Islands. It is clear that at the period when the mean temperature begins to rise above the freezing-point, very much depends on the store of cold existing in the vicinity in the form of snow and ice. The larger it is, the slower and more irregular will be the rise of temperature. At the beginning of winter, also, a heavy fall of snow over a large continental area intensifies and gives a permanency to succeeding cold.

IX. *Prevalent Winds*.—The division of winds into (1) Permanent, (2) Periodic, and (3) Variable, must now be considered. Dr. Theodore Williams well observes that, beyond the use of winds for propelling vessels and machinery, they serve a distinctly hygienic object in dispersing noxious exhalations, whether animal or vegetable, in permitting free evaporation, and thus preventing accumulation of moisture, and maintaining the circulation of the air, which is necessary for the purification of the atmosphere. Their influence upon climate is indisputable. They raise or lower temperature, increase or diminish humidity, cause or prevent rainfall, interrupt sunshine by bringing up clouds, or clear the sky when descending from the higher strata of the atmosphere.

Apart from the permanent aerial currents, which are called the "Trade Winds," and which blow within the Tropics as a north-east wind north of the Equator, and as a south-east wind south of the Equator; and from the periodic aerial currents, of which the most striking examples are the Indian monsoons—the south-west monsoon (of summer) and the north-east monsoon (of winter), there are certain local winds, which prevail occasionally and produce very decided effects upon both animal and vegetable life. This class may be subdivided into *occasional cold winds*, prevalent in winter and spring, and *occasional warm winds*,



prevalent in summer and autumn. On this subject Mr. W. Marriott, Secretary of the Royal Meteorological Society, made a valuable communication at one of the Conferences on "Meteorology in Relation to Health," held at the International Health Exhibition in London in July, 1884.

The cold winds are :

1. The *East Wind* of the British spring, which is dry, cold, and keenly penetrating. The late Sir Arthur Mitchell, in a "Note on the Weather of 1867 and on some Effects of East Wind,"<sup>1</sup> shows how much a cold dry wind must chill the surface of the body by conduction, and also by evaporation. He adds: "The quantity of heat which our bodies lose in this way is far from insignificant, and the loss cannot be sustained without involving extensive and important physiological actions, and without influencing the state of health. In feeble and delicate constitutions the resources of nature prove insufficient to meet the demand made on them, and a condition of disease then ensues."

2. The *Mistral* is a violent north-west wind, dry, cold, and parching, which sweeps the shores of the Gulf of Lions, drying up and withering vegetation, and predisposing to pleurisy and pneumonia in the inhabitants of Provence. Writing of it, Dr. Scott quotes the old couplet :

" Le Parlement, le Mistral, et la Durance  
Sont les trois fléaux de la Provence."

3. The *Tramontana* is a searching northerly blast, which is felt along the eastern shores of the Adriatic. A similar furious northerly wind is known in Trieste and Dalmatia as the *Bora*.

4. The *Nortes* (*Norther*s) of the Gulf of Mexico have a pernicious influence upon health and vegetation. Mr. R. Russell, in his *North America: its Agriculture and Climate*, states that in Southern Texas, in January, 1855, with a Norther, temperature fell from 81° to 18° F. in forty-one hours.

5. The *Pampêro* is a dry, cold, south-west wind, which prevails on the coast of Brazil, blowing with great force across the pampas, or plains, of the River Plate. In the Argentine Republic similar winds are called *Tormentos*.

Dr. C. R. Harper, now of Peckham Rye, London, S.E., in a

<sup>1</sup> *Journal of the Scottish Meteorological Society*, vol. ii., p. 80.

letter to me, dated August 8, 1907, describes a pampero which he experienced off the mouth of the Rio de la Plata, South America. He writes : " The evening was overcast and extremely oppressive, considering we were at the mouth of the River Plate. About 6 p.m. I noticed grit in my mouth and hair, and the ship's deck was covered with a fine layer of sand. When the storm broke about 8 p.m., it was accompanied by intensely vivid lightning, thunder, and torrents of rain. After about one and a half hours it gradually ceased. We dragged our anchor about half a mile, and at times were broadside on, owing to the violence of the wind. An Italian barque was capsized near us, because she had not made herself snug. We could not have rendered any aid, owing to the great noise caused by the storm. We sustained no damage, our fellows, no doubt, having been warned by the barometer."

6. The *Etesian Winds* of South-Eastern Europe blow across the Mediterranean towards North Africa, apparently to supply the place of the heated air which rises from the Sahara and other African deserts.

The chief hot winds are :

1. The *Scirocco*, a hot south-east wind blowing from the immense deserts of Northern Africa. It is a dry wind on the African coast, but blows in Italy and Sicily as a hot, moist wind, from the oppressiveness of which there is no escape. Mr. Marriott states the case well when he says : " Though not fatal to human life, it is deadly to human temper." In Sicily, during its continuance, the thermometer sometimes rises to 110° F. in the shade.

2. The *Solano* is the scirocco of Spain. It is a very hot, dry, and dusty south-east wind, most deleterious to health and to temper ; hence the Spanish proverb : " Ask no favour during the Solano." So also is the *Leveche* or hot south-west wind of the Iberian Peninsula.

3. The *Harmattan* of the west coast of Africa is a hot easterly wind, laden with dust and sand from the Sahara. It prevails in December, January, and February.

4. The *Khamseen*, or *Khamsin*, is the hot wind from the desert in Egypt. It is so called, not because it lasts for fifty

days, but because it is liable to occur during the fifty days following Easter. It blows from S. or S.S.E., the more easterly variety being the most disagreeable. It usually blows for three days, but may last for seven days at a time. The number of Khamseen days in any one year would seem to vary from four to twenty. During its prevalence the air becomes extremely dry, and is filled with fine sand in a highly electrified condition (F. M. Sandwith<sup>1</sup>).

5. The dreaded and deadly *Simoom* of the deserts of Arabia, Kutchee, and Upper Scinde, is really a circular storm, or tornado—in fact, a whirlwind which lasts only ten minutes or thereabouts.

6. The *Hot Wind* of Australia, locally known as a “Brickfielder,” blows from the north. It is most severe in the months of November, December, and January. In Sydney it may send the thermometer up to 100° F.—once it rose to 106·9° F.—but in Central Australia the heat is even more intense, Captain Sturt having reported a shade temperature of 131° F. on January 21, 1845. Dr. Hann, in his *Handbuch der Klimatologie*, p. 639, quotes an observation of Dr. Neumann, formerly Director of the Melbourne Flagstaff Observatory, respecting the hot wind of January 21-22, 1860, that “the apples were literally roasted on the trees, where the north wind had set in.” This north wind is displaced by a sudden south wind which is called a “burster,” and its effect is to reduce temperature with marvellous rapidity.

7. The *Föhn*, or warm, dry wind of the valleys in the north-east of Switzerland, has already been described. So also has been described the *Chinook* wind of the Rocky Mountains, in Western Canada (Chapter XVIII, p. 261, and Chapter XXII., p. 353).

8. The *Leste* is a very dry and parching wind, sometimes very hot, which blows over Madeira from E.N.E. or E.S.E., taking its origin in the Sahara. Its dryness is remarkable, for it traverses 300 miles of sea before it reaches the island.

There is no doubt that, among the elements which make up climate, temperature holds the foremost place. Accordingly,

<sup>1</sup> *Egypt as a Health Resort*, p. 32. London: Kegan Paul, Trench and Co. 1889.

CHART C.

Thermometer showing the Mean Annual Temperature of certain places in various parts of the World.

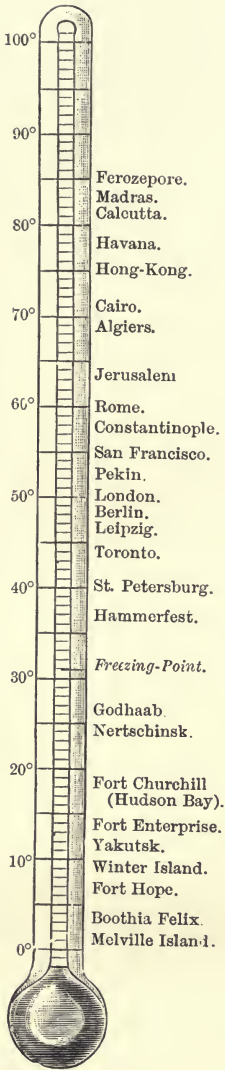

Thermometer showing the HIGHEST and LOWEST Temperatures observed at certain places in various parts of the World.

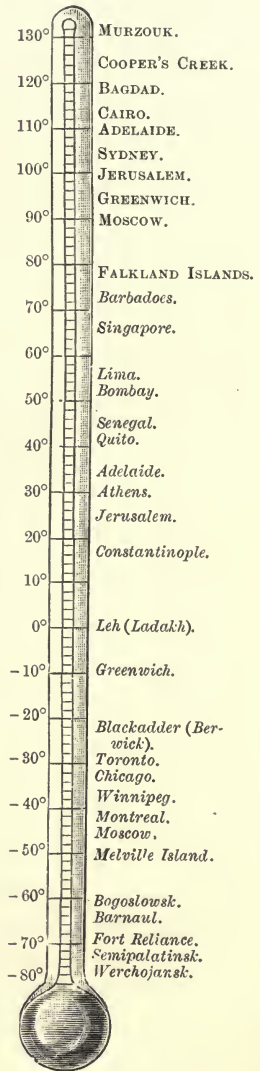



the preceding Chart (C) will both interest and instruct the reader. It was prepared by Mr. William Marriott, F.R.Met.Soc., some years ago by direction of the Council of the Royal Meteorological Society. The mean annual temperature in the shade in degrees Fahrenheit of certain places in various parts of the world is shown on the thermometer scale to the left-hand side, while the highest and lowest shade temperatures, observed at the specified places in all parts of the world, are drawn on the right-hand scale. When the highest temperatures are indicated the names of the places are printed in SMALL CAPITALS ; when the lowest temperatures, in *italics*.

## CHAPTER XXV

### THE CLIMATE OF THE BRITISH ISLANDS

WITHIN the limits of a small book it would be impossible to do full justice to the great theme of Climatology. It must suffice to repeat that, because water by its presence not less than by its motion so profoundly modifies climatic conditions, climates are, by universal consent, divided into *insular* or *moderate*, and *continental* or *excessive*. Of the former, the climate of the British Islands affords a typical example; of the latter, the climate of Siberia may be taken as a type. But an *insular* climate is by no means confined to *islands* (Latin, *insulæ*). The western shores of all continents enjoy moderate climates which are fully entitled to be described as "insular." On the other hand, the interior of continents and their eastern shores are exposed to extremes of heat and cold, which equally justify the appellation "continental," applied to their climate.

The great changes which take place in the distribution of atmospheric pressure over the immense continent of Europe and Asia and the adjoining oceans—the North Atlantic and the North Pacific—have been already described and explained (Chapter XIII., pp. 156-158). It was there shown that, in summer, a vast *cyclonic* system develops over Europe and Asia—the wind blowing against the hands of a watch in accordance with Buys Ballot's Law, round an area of low barometer formed over the heated inland regions, from S.W. in India and China (the south-west monsoon); from S., S.E., and E. in Japan, and North-Eastern Siberia; from N.E. and N. in North-Western Siberia; from N.W. and W. over most of Southern Europe and South-Western Asia.

In winter, on the contrary, over the ice-bound, snow-covered,

boundless Eurasian plain, an immense anticyclone is formed, the winds circulating round and *out from* the centre of high pressure in a direction with the hands of a watch—blowing from N.W. and N. in Japan and China ; from N.E. in India (the north-east monsoon) ; from E. and S.E. in Russia and Southern Europe ; from S.W. in the British Isles ; and from W. in Northern Russia and Siberia.

These considerations facilitate an explanation of the climate of the British Isles (1) in summer and (2) in winter.

It will easily be seen how the summer continental depression influences the climate of the British Isles. Air is drawn from W. and N.W. over these countries, and as this air blows over the surface of a wide ocean and from high latitudes, it is cool and moist. Do not these two words describe our summer ? These ocean winds prevail chiefly on the W. and N.W. shores of Ireland and Scotland, which have thus the rainiest and the coolest summer, while this season is warmer and drier as we go eastward and southward, to the south-eastern counties of England. This is well illustrated in Dr. Buchan's Chart<sup>1</sup> of the Isothermals<sup>2</sup> of the British Isles in July.

It is not necessary to consider at length the influence of the winter system of barometrical pressure on our climate. During the earlier winter months a great stream of warm, very moist air, as a rule, flows north-eastward and northward over these islands round the Atlantic depression, the centre of which lies near Iceland. But this stream does not flow evenly. Along its eastern edge it is in continual conflict with the cold anticyclonic air, which is travelling westward from Russia and Siberia, and immense volumes of the latter are frequently rushing in to supply the place of those volumes of the warm air which, owing to their low density, have presumably risen from the earth's surface towards the higher strata of the atmosphere. The close juxtaposition of two such opposite currents of air causes our storms, and those violent and rapid alternations of temperature which are so prejudicial to health in the winter months.

<sup>1</sup> "The Mean Temperature of the British Islands." By Alexander Buchan. *Journal of the Scottish Meteorological Society*, vol. vi. New Series. No. 64, p. 22. 1882.

<sup>2</sup> Greek, *ἴσος* = equal, and *θέρμη* = warmth.

The reason for the occurrence of these alternations of temperature will be explained when we remember that most of these gales, or *bourrasques*, as they have been termed, are cyclonic in character, and that they generally cross the British Isles from S.W. to N.E., less frequently from W. to E., and still less frequently from N.W. to S.E. The southerly winds which blow over the country in front of the centre of the storms are warm and moist, while the northerly winds, which prevail over those districts already reached and passed by the centre, are cold, and after a time dry. No better examples of this can be given than the remarkable gales of December 8 and 9, 1872, and of February 2, 1873. In front of the former, temperature rose generally to about 50° F. over the south of Ireland, most part of England, and the whole of France; while it fell almost to the freezing-point over those districts a few hours later when the centre had passed. The second gale referred to was accompanied by a range of 18° F. over the whole of France. Dr. Scott says<sup>1</sup> that a great contrast of temperature between adjacent stations—or, so to speak, a great “thermometric gradient”—being an indication of serious atmospheric disturbance, is the precursor or concomitant of a serious storm. He quotes, as an example, the gale of November 14, 1875, which followed hard upon a difference of 36° F. in temperature at 8 a.m. of the previous day between Scilly (57° F.) and Wick (21° F.).

The effect of the warm Atlantic air-current on the Isothermals of the British Isles is well represented in Dr. Buchan’s Chart for January.<sup>2</sup>

Anticyclonic wind-systems sometimes prevail over Western Europe, but much less frequently than cyclonic systems. They cause dry, often cold, weather, and are much more persistent than cyclones.

Anticyclones are better marked, as a rule, in winter than in summer, and historical “hard frosts” in the British Isles are almost invariably connected with one of these systems. The

<sup>1</sup> *Weather Charts and Storm Warnings*, p. 134. London: Henry S. King. 1876.

<sup>2</sup> “The Mean Temperature of the British Islands.” By Alexander Buchan. *Journal of the Scottish Meteorological Society*, vol. vi. New Series. No. 64, p. 22. 1882.



great frost of 1890-91, which lasted in the south-east of England, almost without interruption, from November 25, 1890, to January 22, 1891, was connected with the presence of a large area of high barometric pressure which maintained a nearly permanent position over Central Europe. The incoming disturbances from the Atlantic could not effect a passage into Europe, but were fended off by the European anticyclone, their centres being kept well out in the Atlantic. Ireland and Scotland came from time to time under the warming influence of these Atlantic depressions or cyclones, and consequently the frost was neither severe nor continuous in those countries; but England was not affected by them, and so the cold held in its intensity, particularly in the eastern, south-eastern, and midland parts of the country. Mr. Charles Harding, F.R.Met.Soc. in a paper<sup>1</sup> on this historical frost, states that the very dry character of the weather over England during the frost was also attributable to the fact that the European anticyclone embraced the southern portion of the kingdom, and although on two or three occasions there were some rather heavy falls of snow, the aggregate fall of snow and rain was but trifling in comparison with the average.

In the chapter on "Weather" in his *Elementary Meteorology* (p. 360), Dr. R. H. Scott well observes :

"The weather we experience in Western Europe is distinctly related to these areas of depression and anticyclones, to the rate at which they respectively travel over the earth's surface, and to the distance which intervenes between their respective centres. As in a system of either kind we may meet with winds from any point of the compass, which will have different qualities as to temperature, humidity, etc., according as they belong to one or the other, we see the great importance of the consideration, first pointed out by W. Köppen,<sup>2</sup> and subsequently by Captain Toynbee,<sup>3</sup> that *the climatic character of a wind depends on its origin—i.e., on its belonging to a depression or to an anticyclone.*" He adds : "Anticyclones are generally more or less stationary,

<sup>1</sup> Read before the Royal Meteorological Society on February 18, 1891.

<sup>2</sup> *Repertorium für Meteorologie*, vol. iv. 1875.

<sup>3</sup> *The Meteorology of the North Atlantic during August, 1873*, p. 97. London, 1878.

but depressions move over the earth's surface, usually from west to east in these latitudes, their paths as they advance, though chiefly ruled by the distribution of pressure, being liable to modification by the irregularities of the surface over which they pass; and their effects, as to the amount of cloud and rain to which they give rise, being influenced by the same causes. A south-west wind, for instance, may blow over a flat country with a clear sky, but as soon as the air reaches a hill-side and is forced to ascend, the moisture it contains is condensed, clouds are formed, and rain is frequently the result."

An important contribution to the climatology of England and Ireland is a paper by Mr. Francis Campbell Bayard, F.R.Met.Soc., which was read before the Royal Meteorological Society on June 15, 1892.<sup>1</sup> The author carefully analysed the observations taken during the ten years, 1881-1890, at nineteen Second Order Stations (sixteen in England and three in Ireland), and at thirty-three Climatological Stations (thirty-two in England and one in the Channel Islands), and he arrives at the following general conclusions :

1. With respect to *mean temperature*, the sea-coast stations are warm in winter and cool in summer, whilst the inland stations are cold in winter and hot in summer.

2. The *mean maximum temperature* occurs at all stations in July or August, while the *mean minimum temperature* takes place mostly in December or January, except at Llandudno and the south-western sea-coast stations, where it is later, taking place in February or March.

3. *Relative humidity* is lowest at the sea-coast stations and highest at the inland ones.

4. The south-western district seems most *cloudy* in winter, spring, and autumn, and the southern district the least cloudy in the summer months; and the sea-coast stations are, as a rule, less cloudy than the inland ones.

5. *Rainfall* is smallest in April, and, as a rule, greatest in November, and it increases as we travel from east to west.

Mr. Bayard's paper, it is true, does not include Scotland in

<sup>1</sup> See the *Quarterly Journal* of the Society, New Series, vol. xviii., No. 84, p. 213.

its scope, and three stations in Ireland—Londonderry, Dublin, and Killarney—are far too few to serve as a basis for climatological conclusions. Nevertheless the foregoing sentences epitomise the facts relating to the climate of the British Islands at large. This is shown by referring to a series of elaborate communications on the subject, which Dr. Alexander Buchan from time to time since 1862 laid before the Scottish Meteorological Society.

### I. SEA TEMPERATURES.

In an article on the "Temperature of the British Islands,"<sup>1</sup> Dr. Buchan observed that a very cursory examination of the British isothermals is enough to show the powerful influence of the sea in modifying their course in the different months of the year. Hence, the temperature of the sea which washes our shores is a question of the first importance in investigating the climate of these islands. Observations on sea temperature have been made at different points round the Scottish coasts since 1855, when the Scottish Meteorological Society was founded, and more recently in Faeroe and Iceland. During the three years, July, 1879, to June, 1882, observations, from which maps of the sea temperature all round the British Isles have been constructed in the Meteorological Office, London, were taken at certain coastguard stations, lighthouses, and lightships to the number of forty-nine. The results have been embodied in a Meteorological Atlas of the British Isles, published by the authority of the Meteorological Council in 1883.

In the year ending March 31, 1909, there were in communication with the Meteorological Office fifty-nine sea-temperature stations scattered round the coasts of the British Isles. The Sea-Forecast Districts were twelve in number—namely, Shetland and the Naze, Great Fishery and Dogger Banks, North Sea north of the Wash, North Sea south of the Wash, Straits of Dover, English Channel east of the Isle of Wight, English Channel west of the Isle of Wight, Bristol Channel, St. George's Channel, Irish Sea, North Channel, the Minch. It will be observed that the whole western seaboard of Ireland is left out of this scheme for the

<sup>1</sup> *Journal of the Scottish Meteorological Society*, New Series, vol. iii., 1873. p. 102.

protection of shipping by means of Weather Forecasts and Storm Warnings. Of course, such forecasts and warnings may be sent to Malin Head, Co. Donegal, Blacksod Point, Co. Mayo, and Valentia, Co. Kerry, at each of which places there are land stations in telegraphic communication with the central Meteorological Office, London.

The mean temperatures of the sea surface vary as follows :

<i>January</i>	.. Highest, 49°—Cleggan, Co. Galway ; Scilly, Truro, Penzance. Lowest, 37°—Yarmouth, Berwick.
<i>February</i>	.. Highest, 49°—Scilly, Seven-Stones L.V., <sup>1</sup> Cornwall. Lowest, 37°—Burntisland, Fifeshire.
<i>March</i>	.. Highest, 51°—Cleggan, Co. Galway. Lowest, 40°—Dunrobin, Holkham, Leman and Ower L.V.
<i>April</i>	.. Highest, 51°—Cleggan, Valentia Island, Scilly. Lowest, 42°—Berwick, Leman and Ower L.V., Norfolk.
<i>May</i>	.. Highest, 56°—Valentia Island. Lowest, 45°—Berwick.
<i>June</i>	.. Highest, 58°—West Coast of Ireland, Bristol Channel, Padstow, Cornwall ; Yarmouth. Lowest, 49°—North Unst, Shetland ; Berwick.
<i>July</i>	.. Highest, 62°—Bristol Channel. Lowest, 52°—North Unst, Wick, Berwick.
<i>August</i>	.. Highest, 64°—The Owers L.V., off the Sussex coast. Lowest, 52°—North Unst, East Yell, Shetland.
<i>September</i>	.. Highest, 62°—Cleggan, Co. Galway ; Dover. Lowest, 52°—Shetland.
<i>October</i>	.. Highest, 59°—Mouth of the Thames. Lowest, 47°—Fraserburgh.
<i>November</i>	.. Highest, 54°—Truro. Lowest, 44°—Fraserburgh, Berwick.
<i>December</i>	.. Highest, 52°—St. Agnes' Head, Cornwall. Lowest, 39°—Berwick.

WINTER.—According to Dr. Buchan, the high temperature of the northern islands in winter is one of the best illustrations which could be adduced of the powerful influence of the ocean on climate. The conserving influence of the sea on the temperature is also seen, though in a less degree, in the openings of the Irish Sea and the English Channel. The isothermals indicative of the mildest British climate in winter are seen enveloping Ireland in January. The west and north coasts of Wales share in the genial influence of this offshoot from the warm waters of the Atlantic. The mildest winter climate of Great Britain, however, is found in the peninsula of Devon and Cornwall, which is not only farther south, but is also more completely enveloped

<sup>1</sup> L.V. = Light-vessel.



by the ocean than any other part of the British Islands. A rapid lowering of temperature takes place from the Land's End eastwards to Kent, because the English Channel is comparatively shallow, is near the colder continent, and is connected with the colder North Sea.

SUMMER.—Owing to the great preponderance of sea over land in the vicinity of the Hebrides, the Orkneys, and the Shetlands, the temperature of these islands is remarkably reduced in summer. A tendency to *northing* in the summer winds is also mentioned by Dr. Buchan as another cause for the marked diminution of summer heat in the northern parts of Great Britain. The Irish Sea and the English Channel moderate the heat of summer along their coasts. Conversely, warmth is relatively greatest in those parts of the British Islands which are most removed from the direct and indirect influence of the sea. Hence there is a curving northwards of the isothermals of June, July, and August through the central parts of Great Britain, from the Thames Valley northwards to the Moray Firth. The patch of highest mean temperature corresponds closely with the Thames Valley, and is most marked in the immediate vicinity of London.

In an account of the climate of Dublin, written in 1907, and printed in the *Handbook to the Dublin District*, prepared for the meeting of the British Association for the Advancement of Science which took place in September, 1908, I showed how beneficial was the influence of the Irish Sea upon that city—not only in winter and spring, when it softened and warmed by some 5° F. the keen, dry, searching easterly winds of those seasons—but also in summer. In calm, clear weather in summer time, no sooner has the sun mounted high in the heavens than a cool, refreshing sea breeze—a typical “inbat,”<sup>1</sup> as the modern Greeks call it—sets in towards the land, so that extreme or oppressive heat is rarely experienced. Indeed, an oppressive atmosphere happens only when a damp, warm, south-west wind is blowing, with a more or less clouded sky. On July 15, 1876, the thermometer no doubt did rise in the Irish capital to 87·2° F., but this was altogether a phenomenal occurrence. Temperatures above 80° F. in the screen in Dublin nearly always coincide with winds off the land, from some point between

<sup>1</sup> Evidently a derivative from *ἐμβαίνω*.

south and west, and a clear or only slightly clouded sky. On July 14, 1905, the maximum in Dublin was  $81\cdot8^{\circ}$  F. (practically  $82^{\circ}$ ), with brilliant and hot sunshine, a freshening south-west wind, and the clouds also coming from the south-west. Since January, 1868, the extreme readings of the thermometer in Stevenson's stand recorded at Fitzwilliam Square, Dublin, have been  $87\cdot2^{\circ}$  F. on July 15, 1876, and  $13\cdot3^{\circ}$  F. on December 14, 1882—a range of  $73\cdot9^{\circ}$  F. The average annual range of mean temperature in the forty years 1866-1905 was not quite  $19^{\circ}$  F.—namely, January,  $41\cdot6^{\circ}$  F. ; July,  $60\cdot4^{\circ}$  F.—that is,  $18\cdot8^{\circ}$  F.

Speaking on his paper on the “Mean Temperature of the British Islands,” at a meeting of the Scottish Meteorological Society on July 20, 1881, Dr. Buchan laid special stress on the influence of the Atlantic and other surrounding seas upon the temperature. He pointed out the great influence of the Irish Sea in affecting the course of the isothermals, and also that of the Atlantic, particularly off the north-west of Scotland. In winter the temperature of St. Kilda is as high as that of Penzance, and the temperature at Cape Wrath as high as that of the Isle of Wight. Taking the British Islands as a whole, the mean annual temperature in the west,  $52\cdot0^{\circ}$  F., was represented about the same latitude in the east by a mean annual temperature of  $51\cdot0^{\circ}$  F.—in other words, the west was one degree warmer than the east.

## II. AIR TEMPERATURES.

Observations upon this element fully justify Dr. Buchan's dogmatic statement that “the climate of the British Islands is eminently insular—that is, it is not subject to great extremes of heat and cold, but is remarkably equable throughout the year—being much milder in winter and cooler in summer than in continental regions in the same latitudes.”

We now possess two series of Temperature Charts, which may be accepted as conclusive evidence of the distribution, annually and monthly, of air temperature throughout the British Isles. The first series was drawn up by Dr. Buchan for the Scottish Meteorological Society, originally in 1871. It was based upon observations extending over thirteen years, beginning with January, 1857, and terminating with December, 1869. These

observations on the daily maxima and minima were taken at seventy-six stations in Scotland, sixty-seven in England, twelve in Ireland, and fifteen in adjoining countries on the Continent. The mean temperatures used by Dr. Buchan are the arithmetical means of the daily maximal and minimal thermometer readings. In order to reduce the means so obtained to their sea-level value, they were increased by an addition at the rate of one degree for every 300 feet of elevation above the sea, and were set down, so corrected, in their proper position on thirteen charts, from which the isothermals for each of the twelve months and for the year were drawn. Dr. Buchan's paper will be found in vol. iii. (New Series) of the *Journal of the Scottish Meteorological Society*, 1873, p. 102.

Of this paper a still more elaborate communication on the "Mean Temperature of the British Islands," based on twenty-four years' observations ending with 1880, and laid before the Scottish Meteorological Society by Dr. Buchan in 1882,<sup>1</sup> may be regarded as a revision. The observations embrace a period nearly double the length of that of the earlier paper, and were taken at 24 places in Ireland, 132 in Scotland, and 138 in England. Thus, the series of Plates illustrating this second paper, and giving the isothermal lines for each month, may be accepted as faithfully representing the temperature of the British Islands in exceedingly close agreement with the true mean annual temperature of this portion of the globe—"a datum," says Dr. Buchan, "of no small importance in many inquiries which deal with the physics of the atmosphere and underground temperature."

Plate VI. in the *Atlas of Meteorology*, which constitutes the third volume of *Bartholomew's Physical Atlas*, published in 1899, contains a revision of Dr. Buchan's Isothermal Charts of the British Isles, together with two additional Charts specially prepared for the Atlas. Of these, one shows the annual range of temperature over these islands. It was prepared by Dr. A. J. Herbertson from Dr. Buchan's figures, and demonstrates very clearly the increasing variability of the seasonal temperature from west to east, and more particularly from north-west to

<sup>1</sup> *Journal of the Scottish Meteorological Society*. New Series. Vol. vi., p. 22. 1882.

south-east. The second additional Chart, prepared by Dr. A. J. Herbertson, shows the actual annual temperature over the British Isles, which may be obtained by calculation from the ordinary temperature map in which the isotherms are reduced to sea-level, provided the height of the place and the vertical temperature gradient are known. In this chart the mean actual annual temperature is shown not reduced to sea-level. The isotherms in a great measure follow definite contour lines, but they slope downhill from south to north, and also, to a less extent, from west to east. All the fifteen maps are based on the mean temperatures of 400 stations reduced to the forty-year period, 1856-1895. The lowest mean annual temperature in the British Isles is  $31.2^{\circ}$  F. ( $-0.4^{\circ}$  C.), on the summit of Ben Nevis. The highest mean annual temperature is  $52.2^{\circ}$  F. ( $11.2^{\circ}$  C.), registered in the Scilly Isles and at Truro. The capitals have the following actual mean temperatures: London,  $50.4^{\circ}$  F. ( $10.2^{\circ}$  C.); Edinburgh, 276 feet (84 metres),  $47.1^{\circ}$  F. ( $8.4^{\circ}$  C.); Dublin,  $49.5^{\circ}$  F. ( $9.7^{\circ}$  C.).

The second series of Temperature Charts was drawn up by the authority of the Meteorological Council, and published, in 1883, in the *Meteorological Atlas of the British Isles*. It is based upon observations of the maximum and minimum thermometers made daily during the twenty years 1861-1880 inclusive at seventy-five stations—thirty-one in Scotland and the adjacent islands, thirty-five in England (including the Channel Islands), and nine in Ireland. The mean temperatures given in the Atlas, which consists of twelve monthly maps and one yearly map, are the arithmetical means of the daily maxima and minima. They have been reduced to their sea-level value by the addition of a correction at the rate of one degree Fahrenheit for each 300 feet of vertical elevation. The isotherms in these maps are drawn for each degree, the value for each being inserted in large figures at one of the extremities of each line.

In 1902 the Meteorological Office published temperature tables for the British Islands, together with a supplement giving "Difference Tables for each Five Years for the Extrapolation of Mean Values."<sup>1</sup>

<sup>1</sup> Official Publication, No. 154.



An analysis of the maps in the *Meteorological Atlas of the British Isles* shows that the isotherm of  $46^{\circ}$ , representing the mean temperature of the whole year, skirts the north coasts of the Hebrides and Scotland. The mean temperature then increases as we travel southwards, with many interesting local irregularities, until the isotherm of  $52^{\circ}$  is found off the extreme south-west of Ireland, whence it passes east-south-eastward by the Land's End in Cornwall to Jersey. The mean annual temperature in the Scilly Islands is  $53\cdot1^{\circ}$  (nearly a degree higher than Dr. Herbertson's estimate). Scotland lies between the isotherms of  $46^{\circ}$  ( $45\cdot8^{\circ}$ ) and  $48^{\circ}$  ( $48\cdot3^{\circ}$ ); England between those of  $47^{\circ}$  and  $52^{\circ}$ ; Ireland between those of  $48^{\circ}$  ( $48\cdot4^{\circ}$ ) and  $51^{\circ}$  ( $51\cdot3^{\circ}$ ).

Taking the first month of each quarter of the year, we obtain the following results :

*January*.—The area of greatest cold is represented in Scotland by the isotherm of  $36^{\circ}$ , which embraces Aberdeenshire. Temperature increases from that low value to  $40^{\circ}$  all along the extreme western coast of Argyllshire and the Hebrides to the Shetlands. In England the area of greatest cold is represented by the isotherm of  $37^{\circ}$ , which covers parts of Norfolk, Lincolnshire, Huntingdonshire, and Cambridgeshire near the Wash. The isotherm of  $42^{\circ}$  passes southwards down the west coast of Wales, across the borders of Devon and Cornwall; that of  $45^{\circ}$  just touches the Land's End, while that of  $46^{\circ}$  ( $46\cdot3^{\circ}$ ) passes through the Scilly Islands. In Ireland the isotherm of  $40^{\circ}$  embraces an oval-shaped area on what may be called the "lee-side" of the island, extending from the western, or inland, half of Antrim southwards to the counties Kilkenny and Carlow. The isotherm of  $41^{\circ}$  passes through Dublin south-westwards to Fermoy, and then in a curve towards north-west and north to the extreme north of the island near Lough Swilly. On the other hand, the isotherm of  $45^{\circ}$  sweeps southwards down the extreme western coast from Achill Island to Valentia.

*April*.—This is a transitional month—the characteristic winter isotherms are now giving place to those equally characteristic of summer. In Scotland the isotherms run from north-west to south-east, with local interruptions— $44^{\circ}$  crosses Caithness;  $47^{\circ}$ ,

Wigtonshire and Dumfries. In England the isotherms run in the same direction— $46^{\circ}$  skirting the north-east coast, and  $50^{\circ}$  showing itself near London north of the Thames, and also over Devonshire and Cornwall. In Ireland temperature is very uniform, ranging from  $47^{\circ}$  in the extreme north to  $49^{\circ}$  in Kerry and Cork.

*July.*—The summer distribution of temperature is now seen to full advantage, inland districts being warmest, and coast districts coolest. In Scotland, the isotherm of  $55^{\circ}$  sweeps in a convex curve round the north-west and north coasts from the Hebrides to the Orkneys. The almost circular isotherm of  $59^{\circ}$  covers the centre of Scotland, including Perthshire, Lanarkshire, and the Lothians. The English coasts vary from  $59^{\circ}$  in Northumberland to  $62^{\circ}$  along the shores of the English Channel and Suffolk. Inland,  $63^{\circ}$  covers the Midlands, and  $64^{\circ}$  is found surrounding and especially to the north of London. In Ireland,  $58^{\circ}$  skirts the north, and  $59^{\circ}$  the west coast, while  $61^{\circ}$  embraces a large area extending from the southern shores of Lough Neagh to Cork. Tipperary and North Cork, with Kilkenny and Carlow, enjoy a mean temperature of  $62^{\circ}$ . The great central plain extending from Galway to Dublin is somewhat cooler— $60.4^{\circ}$  to  $60.8^{\circ}$ . This is doubtless due to the immense quantity of water with which the Bog of Allen and other less extensive peat-bogs are charged, as well as to the number of lakes in the centre and west of the country.

*October.*—In this month the winter distribution of temperature begins to appear in the drawing of the isothermal lines. Scotland varies from below  $47^{\circ}$  in the north, north-east, and south-east, to  $49^{\circ}$  in the south-west; England from  $48.4^{\circ}$  in Durham to  $53.6^{\circ}$  at Penzance, and  $55.1^{\circ}$  in the Scilly Islands; Ireland from  $49^{\circ}$  in a large oval in the north and centre to  $52^{\circ}$  in the south-east, and  $53^{\circ}$  off the promontories of Kerry and South-West Cork.

With respect to the reduction of mean temperature to sea-level in these charts, I may remind the reader that, while it is expedient from a scientific point of view that such a reduction should be made, it is quite unnecessary—nay, even misleading—from either an agricultural or a medical standpoint. We want

to know what are the *actual* climatic conditions under which both plants and animals live. Further, in a suggestive address on "The Relations of the Official Weather Services to Sanitary Science," delivered before the American Public Health Association some years ago at a Conference at Mexico, Mr. Mark W. Harrington, the very able Superintendent at that time of the Weather Bureau of the United States Government, wisely and properly pointed out that the meteorological data required by sanitarians and physicians may not be furnished in a form suitable for their purpose. For instance, among the temperature data—for health resorts especially—physicians particularly want to know the *extreme range* as well as the *mean*. Two places may have the same mean temperature—say, 45° F.—but they may be as far apart as the Poles in their relative availability for invalids. One place may have an occasional range of 40° F. within a few hours, the other may not have an absolute annual range of that amount.

"For hygienic purposes," says the writer of the Address, "the details of temperature are of interest, as on a sunny day the temperature may differ greatly in short distances, depending on the exposure and the character of the surroundings. The meteorologist has defined the air temperature as that of the free air at about the height of a man, the thermometer being protected from all radiation. With such a definition the temperature data which could be prepared from observations now taken, and which might be of use to sanitarians, would appear to be as follows :

"The *mean temperatures* of the hours, months, seasons, and year.

"The *mean maxima and minima* for the months, seasons, and year.

"The *absolute maxima and minima* for the same.

"The *mean and absolute amplitudes* for the same.

"*Interdiurnal variability* (*i.e.*, the mean change in mean daily temperatures).

"*List of sharp changes* of temperature of short duration.

"*Frequency of freezing days* (mean temperature less than 32° F.); of *frost days* (minimum temperature below 32° F.);

of *hot days* (maximum temperature, 86° F.); and of *very hot days* (maximum temperature, 95° F.).

“ *Mean and absolute dates of the last and first frosts.* ”

“ *Mean and absolute duration of freezing, of hot, and of very hot weather.* ”

“ *Means of temperature of evaporation (i.e., of the wet-bulb thermometer).* ”

“ This is an element which has not been discussed, so far as known to the writer, though Lieutenant Glassford suggested it to him some time ago. Its significance lies in the fact that it would approximately represent the temperature of the person in hot weather. It would help to distinguish between the distressing moist heat of some stations and the more endurable dry heat of others. It should probably be given in means, and associated with the corresponding air temperature (or temperature by the dry-bulb thermometer). It could be given thus :

Air Temperature.	Mean.	Temperature of Evaporation.
70° to 80°	75°	..
80° to 90°	85°	..
90° to 100°	95°	..
100° or more	..	..

“ A similar table for low temperatures might be of use, as it is thought that dry, cold weather is less hard to endure than wet, cold weather.”

### III. ATMOSPHERIC PRESSURE.

The *Meteorological Atlas of the British Isles* (1883) includes also thirteen maps, showing the distribution of mean barometrical pressure over the United Kingdom for each month and for the whole year, during the twenty years 1861-1880. For purposes of comparison the readings have in all cases been reduced to their mean sea-level value ; but I agree with the Superintendent of the Weather Bureau of the United States Government in thinking that, from a hygienic or medical point of view, it is the pressure to which an individual is actually exposed, and not that felt



at sea-level, perhaps 1,000 feet below him, which is required in investigations as to the influence of climate on health.

This view was evidently shared by the compilers of the Atlas, for each map bears the following "Note":

"The approximate mean pressure for the month (or year) may be found by subtracting from the pressure indicated by the nearest isobars a correction obtained as follows: From 1·21 inches, subtract for each 10° above zero, F., ·025 inch; the residue will be the correction for an elevation of 1,000 feet, and the correction for the actual elevation will be proportional to this."

The barometrical maps, moreover, are full of interest, particularly as the monthly distribution of pressure gives a clue to the direction and force of the predominant winds.

In this series of maps, isobars have been drawn for the even hundredths of an inch of pressure, so as to correspond as nearly as practicable with the actual observations recorded. The readings are reduced to sea-level, and also to 32° F.

In the chart for the whole year, and, indeed, in that for every one of the twelve months, the isobars have a cyclonic or concave trend in the north, but an anticyclonic or convex trend over the south of the United Kingdom. This at once explains the more settled weather of the south contrasted with the less settled weather of the north. Next, we observe that throughout the year pressure is on the average lower in the north than in the south. The differences in pressure are not uniform, however, throughout the year. Thus, in January the isobar of 29·66 inches runs across the extreme north of Scotland from south-west to north-east, that of 29·98 inches crosses Kent in a north-easterly direction. Here we have a difference of pressure amounting to ·32 of an inch, and gradients for *south-westerly* winds over the whole kingdom. This difference steadily diminishes from January through February (when it is ·22 inch—29·74 and 29·98 inches), March (·14 inch—29·76 and 29·90 inches), April (·10 inch—29·86 and 29·96 inches), to May, when it is only ·08 inch—29·91 inches and 29·99 inches. It will at once occur to the reader that this equalisation of pressure means the dying out of the strong south-west winds of winter, and the inter-

spersing of a large proportion of easterly winds with the predominant westerly winds of our latitudes. Once May has passed a gradual reverting to the winter type of distribution may be noticed, thus :

<i>June</i>	..	N. 29·88 inches ;	S. 30·01 inches—	difference, ·13 inch.
<i>July</i>	..	N. 29·84	” S. 30·00	” ” ·16 ”
<i>August</i>	..	N. 29·82	” S. 29·98	” ” ·16 ”
<i>September</i>	..	N. 29·76	” S. 29·96	” ” ·20 ”
<i>October</i>	..	N. 29·72	” S. 29·92	” ” ·20 ”
<i>November</i>	..	N. 29·74	” S. 29·94	” ” ·20 ”
<i>December</i>	..	N. 29·70	” S. 29·98	” ” ·28 ”

I have compared these values with those given in Dr. Buchan's charts of the isobars, showing in inches the mean atmospheric pressure of the British Isles, monthly and yearly, on an average of forty years, ending with 1894, and I find a remarkable agreement between the two sets of observations.

A necessary consequence of the changes in the monthly distribution of atmospheric pressure above indicated is, that January is the stormiest month in the British Isles. A careful analysis of the reports of storms received at the Meteorological Office, London, for the fourteen years, 1870-1883, has led Dr. R. H. Scott to the conclusion that there is no strongly-marked storm-maximum at either equinox—in September storm prevalence is increasing from a marked minimum in June and July ; in March it is decreasing from a sharply-defined maximum in January. Equinoctial gales, as such, are non-existent.<sup>1</sup>

<sup>1</sup> *Quarterly Journal of the Royal Meteorological Society*, vol. x., p. 236. 1884.

## CHAPTER XXVI

### THE CLIMATE OF THE BRITISH ISLANDS (*continued*)

#### IV. RAINFALL.

IT is well said by Dr. A. Buchan, in his third paper on "The Climate of the British Islands,"<sup>1</sup> that, as regards these islands, the greatest differences in local climates arise from differences in the rainfall. Thus, on comparing the climate of Skye with that of the southern coasts of the Moray Firth, their mean temperatures in no month differ so much as 2·0°, and for several months of the year they are nearly identical. But the annual rainfall of Skye rises to, and in many places exceeds, 100 inches, whereas at Culloden it only amounts to 26·17 inches (24·6 inches in the twenty-five years 1866-1890), and at Burghead to 25·23 inches. This difference in the rainfall, with the clear skies and strong sunshine which accompany it, renders the south shore of the Moray Firth one of the finest grain-producing districts of Scotland. It is this aspect of the rainfall which gives it so prominent a place in the climatology of a country.

Dr. Buchan's article on "The Annual Rainfall of the British Islands" is based on observations of the rainfall made at 547 stations in Scotland, 1,080 in England and Wales, and 213 in Ireland; in all, 1,840. The period selected for discussion was the twenty-four years extending from 1860 to 1883, inclusive. Dr. Buchan handsomely acknowledges his obligations to Mr. Symons's *British Rainfall*, a publication which rendered such an inquiry possible. The observed, but in some instances calculated, twenty-four years' averages were transferred to a map of the British Islands, which was then coloured with six different tints

<sup>1</sup> *Journal of the Scottish Meteorological Society*. New Series. Vol. vii., p. 131. 1886.

—these shadings showing the districts where the mean annual rainfall did not exceed 25 inches (*pale pink*), was from 25 to 30 inches (*red*), from 30 to 40 inches (*dark red*), from 40 to 60 inches (*pale blue*), from 60 to 80 inches (*blue*), and, lastly, above 80 inches (*dark blue*).

In the *Meteorological Atlas of the British Isles* (1883), the rainfall for the whole year is shown on a map by lines drawn, for each 5 or 10 inches of rain, from place to place having the same annual rainfall. This rainfall map was constructed by plotting on a large scale all the mean annual rainfall values for the fifteen years 1866-1880, inclusive, which are given in *Rainfall Tables of the British Isles*, compiled from the records of 366 stations by Mr. G. J. Symons, F.R.S., and published by the authority of the Meteorological Council in 1883. The rainfall indicated by the lines upon a map, drawn on a reduced scale for the Atlas, is the mean quantity actually observed at these selected stations. It is not claimed that this map is perfect, for a much larger amount of rain is known to fall in some places, notably on mountain slopes, of which no such record exists as to admit of its being shown on so small a map. In Ireland and the west of Scotland this defect is aggravated by the fact that for large areas no record whatever is obtainable for the period embraced in the inquiry.

It should be mentioned that the Rainfall Tables, prepared by Mr. Symons at the request of the Meteorological Council, are illustrated by three coloured maps of England, Scotland, and Ireland respectively, which exhibit, not only the geographical position of the 366 stations furnishing the rainfall records, but also the area in square miles of the river catchment basins in which these stations are severally situated.

The key to the distribution of rainfall in the British Islands is "the direction of the rain-bearing winds in their relation to the physical configuration of the surface" (Buchan).

The regions of heaviest rainfall, 60 to 80 inches or upwards, are: Skye and the Western Highlands, the Lake District in Cumberland and Westmoreland, the mountainous district in North Wales, the mountainous district in the south-east of Wales, Dartmoor in Devonshire, the Highlands of West Galway,



and the neighbourhood of Killarney and the Macgillicuddy's Reeks in Kerry. This distribution of heavy rainfall is determined by (1) prevalent south-west winds, blowing vapour-laden from the Atlantic Ocean; (2) the exposure to these winds of mountains, or high tablelands like Dartmoor, with valleys opening to the westward or south-westward. On the mountain slopes the warm, moist air is condensed into mist, cloud, and rain.

Over the south of Scotland the rainfall is not excessive, because the rain-bearing south-westerly winds have been partially dried in their passage across Ireland before they reach the district in question.

The absolutely largest annual rainfalls are: In *Scotland*, at Ben Nevis summit, 4,404 feet above the sea, [fifteen to eighteen years] (151 inches), and at Glencroe, Argyllshire, at an elevation of 520 feet (128·50 inches); in *England*, at the Styne, Cumberland, 1,077 feet (185·96 inches—so far as yet observed, the heaviest rainfall anywhere in the British Islands), at Seathwaite, Cumberland, 422 feet (143·21 inches in the twenty-four years 1860-1883; 139·29 inches in the fifteen years 1866-1880); in *Wales*, at Beddgelert, Carnarvonshire, 264 feet (116·90 inches), Rhiwbrifdir, Merionethshire, 1,100 feet (102·56 inches), Ty-Draw-Treherbert, Glamorgan, 735 feet (96·18 inches), Glyncorrwg, Neath, [twenty years] (87·5 inches); in *Ireland*, on Mangerton, near Killarney, [eight years] (86 inches), at Kylemore, County Galway, 105 feet, [fifteen years] (77·6 inches), at Foffany, County Down, 920 feet (72·26 inches), at Newcastle, County Down, and at Derreen, Kenmare, County Kerry, 74 feet (69·40 inches).

A rainfall of 40 inches a year, or upwards, occurs over about a fourth part of the surface of England and Wales, about half of that of Ireland, and considerably more than half of that of Scotland (Buchan). Nowhere along the whole east coast of Great Britain, or for some distance inland, does the average yearly rainfall reach 40 inches. On the east coast of Ireland, however, the rainfall rises to, or exceeds, 40 inches in the mountainous districts of Wicklow, Down (the Mourne Mountains), and Antrim. On the other hand, the annual rainfall is well below 30 inches in Dublin and its vicinity, for reasons which have been already explained (see Chapter XXIV., p. 363).

Wherever mountains or "downs" run east and west, a heavy rainfall is propagated eastwards along their southern face, while the precipitation is diminished to the northward of the barrier which they oppose to the rain-bearing south-west winds. Thus the mountains of Sutherland, the Grampians, the Cheviots, the Pennine Range, and the Downs of the south of England, all cause an extension eastward of a heavier rainfall along their southern slopes, but a diminution in the rainfall to the northward and north-eastward. Precisely the same thing on a smaller scale is found in connection with the Pentland Hills, near Edinburgh, the Mourne Mountains in the County Down, and the Dublin and Wicklow mountains. Leith (28·00 inches), Edinburgh (28·31 inches), Donaghadee (31·08 inches), and Dublin (27·672 inches in the forty years 1866-1905), all owe their comparatively small precipitation to their geographical position north-east of the mountain ranges mentioned. The rainfall at Belfast (Queen's College) is, on the average, 34·73 inches. This is no doubt due to the proximity of Divis and other mountains north-west of the city, heavy rains falling with south-east winds, which impinge upon those hills.

"The influence of the breakdown of the watershed of Scotland between the Firths of Forth and Clyde," writes Dr. Buchan, "is strikingly manifested in the overspreading of western parts of Perthshire, Stirlingshire, and Dumbartonshire, with a truly western rainfall as regards amount, and the direction of the winds with which it falls; and in the extension eastwards, through Kinross-shire, of a rainfall of fully 40 inches, which occurs nowhere else over comparatively level plains so far to the east of the watershed separating the western and eastern districts."

Turning to the regions of least rainfall, we find a large area in England, extending from the Humber to the estuary of the Thames (exclusive of the higher grounds of Lincoln and Norfolk), over which the annual precipitation falls short of 25 inches. In Cambridgeshire it is generally about 23 inches, except at Wisbech Observatory, where it rises to 26½ inches. The smallest rainfall of all is at the eastern point of Spurn Head, Yorkshire (ten years), 19·1 inches. At Shoeburyness, in Essex, the average for the twenty-five years 1866-1890 was only 20·6 inches. In

1874 only 14·20 inches fell at this station. On the higher grounds of Lincoln and Norfolk the rainfall exceeds 25 inches, because the precipitation with easterly winds is increased. Similarly, the rainfall of the Yorkshire Wolds is made to exceed that of neighbouring districts. A small patch in the valley of the Thames, from Kew to Marlow, in Bucks, has an annual fall of less than 25 inches—Kew Observatory, twenty-four years 1860-1883 = 25·26 inches ; fifteen years 1866-1880 = 24·67 inches. Between the valley of the Thames and the Humber the rainfall nowhere reaches 30 inches, except near the Chiltern Hills (Buchan).

In Scotland the annual rainfall falls short of 30 inches in the north-eastern part of Caithness, round the Moray Firth from Tain to the mouth of the Spey, along the east coast from Peterhead in Aberdeenshire to Burntisland in Fifeshire, the low ground of Midlothian and East Lothian, and lower Tweeddale from Kelso to Berwick. The absolutely smallest rainfalls are observed on the very shores of the Moray Firth from Tarbet-Ness to Burghead (25 to 28 inches), the extreme north-east of East Lothian (25 to 29 inches), and the lower Tweed from Coldstream to Jedburgh (26½ inches). Nairn, in the twenty-five years 1866-1890, had only 23·3 inches annually on the average.

The only parts of Ireland where the rainfall falls short of 30 inches are Dublin and its vicinity (about 28 inches) and Dundalk (29·9 inches on an average of ten years). The reason for this diminished rainfall has been given above (p. 363).

#### V. GEOLOGICAL FORMATION.

In a lecture on "The Physical Influences which affect the British Climate," delivered early in the year 1893, in the Public Health Department of King's College, London,<sup>1</sup> Mr. H. G. Seeley, F.R.S., Professor of Geography in the College, aptly observes : "The areas of heavier rainfall are the regions of higher land, and a rainfall map in England closely approximates in its broad features to a geological map." Allusion has already been made to the marked influence on rainfall exercised by the high lands and mountain chains in various parts of the United Kingdom.

<sup>1</sup> See *The Journal of State Medicine*, vol. i., No. 4, p. 165. April, 1893.

The configuration of the coast-line and the distribution of high and low ground govern the rainfall to a remarkable extent, and in this way control climate generally. As Mr. Seeley remarks, "Next to the situation of our islands upon the earth's surface, the most important element in climate is the geological structure and contour of the surface of the country."

In his lecture Professor Seeley shows that there are two ways in which the geological structure affects climate: first, it has a local influence on temperature; secondly, it is a main element in modifying the relative durability of the rock material which determines the elevation of the surface. It would be foreign to the purpose of this book to enter into details as to the geology of the British Islands. Suffice it to say, with Professor Seeley, that the chief geological formations which have a bearing upon climate may be classed as (1) pebble beds, sands, and sandstones; (2) clays and shales; (3) limestones. There are, in addition, certain altered conditions of these simple forms, in which a more or less crystalline texture is developed, which may be the micro-crystalline texture of slate or the micro-crystalline texture of schist.

1. The pebble beds, sands, and sandstones are commonly warmer and drier than other rocks. Their *dryness* is due to the existence of porous interspaces between the quartz grains of which these rock forms are so largely composed. This wholesome property may be interfered with by the presence of a cement which will bind the grains of quartz together, or of a bed of clay, which will render the sand impervious. The dryness, or otherwise, of sand strata will also largely depend on the angle at which they are inclined; horizontal strata are naturally less dry than inclined strata. The *warmth* of a sandy soil is probably due to its dryness as well as to the low specific heat of the quartz.

2. The particles of which *clays* are composed are extremely small, and consist chiefly of silicate of alumina. Some clay soils contain as much as 40 per cent. of alumina, but the usual proportion is much smaller. In Scotland clay soils are found chiefly on the coal-measures, the boulder clay, and as alluvium in the valleys. The last named is the richest form of clay and is known as *carse* clay. In the North of England, the aluminous



shales of the coal-measures yield soils in their properties very like those in Scotland. England also abounds in clay soils derived from other geological formations, such as London clay, plastic, weald, gault, and blue lias clay. An astonishing quantity of water may be held in a clay soil, which has an almost boundless affinity for moisture. In a warm, dry summer, wide and deep chasms open in clay, owing to the evaporation of the water it contains. Clay land is looked upon as cold—a condition attributed by Professor Seeley, theoretically, to the small size of its constituent particles and the way in which they are divided from each other by films of water. Through evaporation from a clay soil, the superincumbent atmosphere is rendered moist and cool. Precisely the same effect is produced in Ireland by the water-soaked morasses or *bogs*, which, according to Sir Robert Kane, M.D., cover 2,830,000 acres, or about one-seventh part of the entire surface of the island. The Bog of Allen stretches in a vast plain across the centre of the island, having a summit elevation of 280 feet. Its apparent influence on the mean temperature has been alluded to above (see p. 390).

Owing to the retentive and non-porous nature of clay soils, there is no deep filtration and underground storage of water. The superficial strata become water-logged, and the imprisoned waters are very liable to contamination with surface impurities or with the products of chemical decomposition in the clay itself.

3. The third great group of water-formed rocks is that of the *limestones* (Seeley). The carboniferous limestone covers an immense area in the Pennine Chain and North of England, and forms the base of nearly all our coalfields. It also underlies the peat-moss bogs of Central Ireland. The oolitic limestones, more or less continuous, and chalk, stretch from the Yorkshire coast to the South of England, forming parallel ridges of hills. Being soluble under flowing waters charged with carbonic acid gas, the surface is always deeply scored with valleys (Seeley). The ancient and oolitic limestones are not as absorbent as the newer chalk, which is very pervious to water. As water percolates through these limestones, it becomes highly charged with lime salts. According to Professor Seeley, limestones always give up a good deal of vapour under sunshine, and have

a warm steamy atmosphere above them in summer, which is in marked contrast to the bracing air of sandstones with silicious or calcareous cements. When there is even a thin bed of clay on the summit of a limestone ridge, such as forms the insoluble residue left by atmospheric denudation, the climatic conditions are changed.

4. The crystalline rocks, whether slates or schists, usually occur in elevated country in the West of England, in Scotland, and in parts of Ireland. They are remarkable, chiefly, for their impervious and almost insoluble character. "The high and irregular ground which they form, like their western position, causes them to have a great effect in radiating heat, and therefore in producing winds which descend from the mountainous regions, and in condensing rain."

Professor Seeley, in the paper from which I have so largely quoted, observes with justice that "the influence of the soil upon climate is complicated by the effects of the climate in transporting and forming the superficial soil."

The foregoing sketch of the climate of the British Islands may fitly conclude with Climatological Tables for the City of Dublin, lat.  $53^{\circ} 20' N.$ , long.  $6^{\circ} 15' W.$ , altitude 18 to 67 feet.

TABLE VII.—SHOWING THE AVERAGE MEAN TEMPERATURE, ATMOSPHERIC PRESSURE, RAINFALL, AND RAIN DAYS IN THE CITY OF DUBLIN DURING THE FORTY YEARS 1866-1905.

Month.	Average.			
	Mean Temp.	Pressure.	Rainfall.	Rain Days.
	° F.	Inches.	Inches.	
January ..	41·6	29·913	2·287	18·0
February ..	42·5	29·915	1·954	15·8
March ..	43·4	29·892	2·030	16·9
April ..	47·6	29·896	1·913	15·7
May ..	51·9	29·976	2·027	14·9
June ..	57·7	29·994	1·912	14·3
July ..	60·4	29·948	2·510	16·6
August ..	59·5	29·917	3·130	17·0
September ..	55·8	29·938	2·243	15·2
October ..	49·5	29·887	2·803	17·4
November ..	45·1	29·896	2·587	16·6
December ..	41·9	29·863	2·275	17·5
Annuals ..	49·7	29·920	27·672	195·9

The materials for Table VII. (see p. 402) were culled from the records of observations taken by me in the City of Dublin during the forty years 1866-1905, inclusive.

The following averages of temperature, rainfall, and duration of bright sunshine are based on observations taken during the thirty-five years, 1871-1905, at three Normal Climatological Stations situated in the Irish metropolis. They are extracted from Appendix III. of the *Weekly Weather Report*, 1906, published by the Meteorological Office, London.

*Trinity College Meteorological Observatory.*—In January, 1904, the Provost and Senior Fellows of Trinity College established a Normal Climatological Station within the precincts of the College. The station occupies an open space in the Fellows' Garden, and is fully equipped. In addition to the usual instruments—barometer, dry-bulb, wet-bulb, maximum and minimum thermometers, and rain-gauge, all of which are read at 9 a.m. and 9 p.m.—the equipment includes a Campbell-Stokes sunshine-recorder and two earth-thermometers, of which the bulbs are placed underground at a depth of 1 foot and 4 feet respectively. The Observatory is under the superintendence of Erasmus Smith's Professor of Natural and Experimental Philosophy, W. E. Thrift, M.A., F.T.C.D.

The tables on pp. 405-406 have been compiled from the records of this Climatological Station, extending over the five years 1904-1908, inclusive. They show the monthly and yearly values of the underground temperatures at 4 feet, and of the duration of bright sunshine in hours and percentages.

## TEMPERATURE.

Month.	Dublin City (Fitzwilliam Square).			Royal Botanic Gardens (Glasnevin).			Ordnance Survey (Phoenix Park).		
	Mean Max.	Mean Min.	Mean.	Mean Max.	Mean Min.	Mean.	Mean Max.	Mean Min.	Mean.
	° F.	° F.	° F.	° F.	° F.	° F.	° F.	° F.	° F.
January ..	46·0	37·4	41·7	45·8	35·2	40·5	45·5	34·7	40·1
February ..	46·9	37·9	42·4	47·1	35·3	41·2	46·5	34·7	40·6
March ..	49·2	38·2	43·7	49·3	35·6	42·4	48·7	35·0	41·9
April ..	53·6	41·5	47·6	53·5	38·4	46·0	52·8	37·8	45·3
May ..	58·8	45·5	52·2	58·2	41·9	50·1	57·7	41·3	49·5
June ..	64·5	51·3	57·9	64·5	47·9	56·2	63·9	47·1	55·5
July ..	66·8	54·2	60·5	67·0	51·3	59·2	66·1	50·6	58·4
August ..	65·7	53·6	59·7	66·2	50·7	58·5	65·4	50·1	57·7
September ..	61·7	50·2	55·9	62·4	47·0	54·7	61·6	46·3	54·0
October ..	54·7	44·3	49·5	55·2	41·4	48·3	54·5	41·1	47·8
November ..	49·9	40·8	45·3	50·0	38·2	44·1	49·6	37·7	43·7
December ..	46·3	37·6	42·0	46·0	35·0	40·5	45·8	34·6	40·2
Whole Year	55·3	44·4	49·9	55·4	41·5	48·5	54·8	40·9	47·9

The respective heights of the three stations above mean sea-level are : Fitzwilliam Square, 47 feet ; Glasnevin, 67 feet ; Phoenix Park, 155 feet.

## RAINFALL AND RAIN DAYS.

Month.	Dublin City (Fitzwilliam Square).		Royal Botanic Gardens (Glasnevin) (1875-1905).		Ordnance Survey (Phoenix Park).	
	Rainfall in Inches.	Rain Days.	Rainfall in Inches.	Rain Days.	Rainfall in Inches.	Rain Days.
January ..	2·21	18	2·28	15	2·24	20
February ..	2·01	15	1·99	14	1·89	17
March ..	1·91	17	2·05	14	2·03	19
April ..	1·94	16	1·94	14	1·84	17
May ..	1·97	15	2·01	13	1·99	16
June ..	1·99	15	2·08	13	2·08	15
July ..	2·68	17	2·75	16	2·84	19
August ..	3·24	18	3·45	17	3·32	19
September ..	2·21	15	2·33	13	2·22	16
October ..	2·87	18	2·86	16	2·85	19
November ..	2·72	17	2·78	15	2·87	19
December ..	2·25	17	2·29	16	2·35	19
Totals ..	28·00	198	28·81	176	28·52	215



TABLE VIII.—SHOWING THE MONTHLY AND YEARLY DURATION OF BRIGHT SUNSHINE IN HOURS, WITH THE PERCENTAGE OF THE GREATEST POSSIBLE DURATION, TOGETHER WITH THE AVERAGES FOR FIVE YEARS, RECORDED IN TRINITY COLLEGE, DUBLIN.

Month.	1904.		1905.		1906.		1907.		1908.		Average.	
	Hours.	Per Cent.	Hours.	Per Cent.	Hours.	Per Cent.	Hours.	Per Cent.	Hours.	Per Cent.	Hours.	Per Cent.
January ..	45.3	18	39.5	16	42.7	17	47.0	19	33.7	14	41.6	16.80
February ..	37.3	13	84.9	31	84.6	31	76.0	28	46.8	17	65.9	24.00
March ..	89.8	25	146.0	40	122.8	34	138.0	38	104.0	29	120.1	33.20
April ..	168.0	40	105.0	25	182.0	44	117.0	28	138.8	33	142.2	34.00
May ..	192.5	39	215.7	44	132.5	27	173.0	36	193.9	40	181.5	37.20
June ..	231.5	46	217.6	44	210.3	42	129.0	26	181.4	36	194.0	38.80
July ..	201.0	40	162.2	32	184.8	37	173.0	35	174.3	35	179.1	35.80
August ..	183.8	41	121.9	27	176.9	39	151.0	34	148.7	33	156.5	34.80
September	150.0	40	120.4	32	169.4	45	98.0	26	101.0	27	127.8	34.00
October ..	84.3	26	92.7	29	99.7	31	55.5	17	87.6	27	84.0	26.00
November ..	35.2	14	47.3	19	43.8	17	34.0	13	48.1	19	41.7	16.40
December ..	33.3	15	31.3	14	19.9	9	24.0	10	21.3	9	26.0	11.40
Yearly Totals and Means	1452.0	33	1384.5	31	1469.4	34	1215.5	28	1279.6	29	1360.4	31.00

TABLE IX.—SHOWING THE MONTHLY AND YEARLY MEAN TEMPERATURE OF THE SUBSOIL AT A DEPTH OF 4 FEET BELOW THE SURFACE, TOGETHER WITH THE AVERAGE SUBSOIL TEMPERATURE FOR THE FIVE YEARS 1904-1908, RECORDED IN TRINITY COLLEGE, DUBLIN.

Month.	1904.	1905.	1906.	1907.	1908.	Average.
	° F.	° F.	° F.	° F.	° F.	° F.
January .. ..	42·9	44·7	44·7	44·0	43·0	44·6
February .. ..	42·5	44·2	43·4	42·2	44·3	43·3
March .. ..	43·3	44·1	44·0	44·2	43·9	43·9
April .. ..	46·3	46·4	45·9	46·4	45·8	46·2
May .. ..	50·0	50·3	48·6	49·8	50·0	49·7
June .. ..	54·2	54·6	53·9	52·9	54·1	53·9
July .. ..	56·7	58·6	56·5	55·7	57·7	57·0
August .. ..	57·9	58·5	58·4	57·3	58·4	58·1
September .. ..	56·4	56·1	58·0	56·3	56·2	56·6
October .. ..	53·2	51·9	54·0	53·8	55·6	53·7
November .. ..	50·0	46·7	48·8	49·4	51·2	49·2
December .. ..	45·3	45·6	46·7	45·3	47·1	46·0
Yearly means	49·9	50·1	50·2	49·8	50·6	50·1

*Is our Climate changing?* To this question I endeavoured to give an answer in a paper read before the Cosmical Physics Subsection of the Section of Mathematics and Physics, at the Dublin Meeting of the British Association for the Advancement of Science, September, 1908.

In 1770 Dr. Thomas Rutton published an octavo work of 340 pages, entitled *A Chronological History of the Weather and Seasons, and of the Prevailing Diseases in Dublin*. The results of forty years' observations are recorded in this most valuable volume. More than a century earlier Dr. Gerard Boate, State Physician to the Parliamentary Forces in Ireland, made observations on climate and diseases, and, with the assistance of his brother Arnold, who had been for many years a medical practitioner in Dublin, wrote his work on *Ireland's Natural History*. It was first published in London in 1652, three years after Gerard Boate's death. A French edition appeared in Paris in 1666.<sup>1</sup>

From 1805 to 1841 Dr. Thomas H. Orpen made observations on the weather in Dublin, which are still preserved in manu-

<sup>1</sup> *Census of Ireland*, 1851. Part V., "History of Epidemic Pestilences in Ireland, A.M. 2820 to A.D. 1851."

script in the Library of the Royal Irish Academy. Some years of Dr. Orpen's Tables were likewise published in the *Dublin Philosophical Journal* in 1825, which also contains a meteorological table for 1823-24, by Mr. Semple, of Malahide. From 1829 down to the present time a careful series of observations has been made at the Ordnance Survey Office, Mountjoy Barracks, in the Phoenix Park, and at the beginning of the nineteenth century the observations taken at the Royal Botanic Gardens, Glasnevin, were published yearly in the *Proceedings of the Royal Dublin Society*.

Rutty's remarks on the weather in the early years of the eighteenth century would serve to describe accurately the weather of the twentieth century. Here is one brief quotation :

1760-61. "The winter very open and warm. December and January windy and stormy."

And then this shrewd observer remarks : "December (1760) was healthy, as was this whole winter quarter, though uncommonly wet and warm, an express contradiction to the vulgar tradition that a green Christmas makes a fat churchyard" (p. 254).

1763. "A remarkably cold and wet summer, but healthy. . . . The wet summer, particularly the month of August, was less productive of diarrhoeas, dysenteries, and the cholera than drier and warmer seasons, which seems to furnish occasion for refuting a vulgar and long-established error and prejudice respecting the cause of these diseases, which have been ordinarily attributed to an obstructed perspiration and the use of fruit in the summer and autumn" (pp. 297, 298).

Having extracted evidence from the records of the past which goes to prove that the climate of the British Isles was much the same long ago as it is at the present day, I submitted, in further proof of this contention, the results of my personal observations in Dublin through a long series of years. As a matter of fact, I have kept a Weather Journal since the year 1861 to the present date. The period dealt with began with the year 1866, and ended with the year 1905—that is to say, an even period of forty years, or of eight lustrums. My son, Maurice Sydney Moore, B.A. Dublin, prepared the tables, which set forth the mean

temperature, rainfall, rain-days, and atmospheric pressure of the period, and worked out the necessary calculations.

The average annual mean temperature of the forty years was  $49.7^{\circ}$  F., the lustrum averages being— $50.1^{\circ}$ ,  $50.2^{\circ}$ ,  $49.3^{\circ}$ ,  $49.4^{\circ}$ ,  $48.6^{\circ}$ ,  $49.4^{\circ}$ ,  $50.8^{\circ}$ , and  $50.0^{\circ}$  F.

A careful study of the analysis of the behaviour of temperature in the forty years under discussion shows that, no matter what fluctuations take place between individual months in successive years or between individual years in successive lustrums, the temperature pendulum swings back to its original position at either side of the average. The question of periodicity in such movements awaits solution.

Even in the matter of rainfall, with the wide swing of the pendulum from 45 per cent. in excess, to 40 per cent. in defect of the average—that is, from a maximal yearly fall of 35.566 inches to a minimal fall of 16.601 inches—we see a tendency to return to that average as the years roll by.

In the forty years, 1866-1905, the mean annual atmospheric pressure was lowest—29.731 inches—in 1872, and highest—30.015 inches—in 1887. In 1872 the monthly pressure was below the average in every month except in April and August. In 1887 the monthly pressure was above the average except in January, September, November, and December.

In conclusion, the facts which I put forward in this paper prove that, within the past six centuries at all events, no appreciable change has taken place in the climate of the British Isles.

There is not a scintilla of evidence to show that—within historic times—any such change has taken place in the past, or is likely to take place in the future. The weather—“*varium et mutabile semper*,” as it is—resembles the river which, in the words of Horace, “*Labitur, et labetur in omne volubilis ævum.*”



## PART IV.—THE INFLUENCE OF SEASON AND OF WEATHER ON DISEASE

### CHAPTER XXVII

#### ACUTE INFECTIVE DISEASES

OBSERVATIONS as to the influence of weather upon health are as old as meteorology itself—nay, older, if we admit that Aristotle was the founder of the science. More than four hundred years before Christ, Hippocrates of Cos, the “Father of Medicine,” had penned his immortal *Aphorisms*, and had written “Περὶ ἀέρων, ἰδάτων, τόπων” (*On Air, Waters, and Places*), and “Περὶ διαίτης” (*On Regimen*). In these works we meet with passages as applicable to-day as they were some twenty-four centuries ago.

The suggestions thrown out by the Greek physician were allowed to remain almost a dead-letter. His doctrines as to the close relations of Climatology to Medicine became dimmed by the rust of time, and were neglected or forgotten.

In the Introduction to his splendid *Geographical and Historical Pathology*, August Hirsch observes that only in a few of the best Greek and Roman medical authors, such as Celsus, Asclepiades, and Aretæus, do we find here and there indications that they gave some attention to the various effects of “climate” and “diet” upon the human organism in health and disease. Such questions were unfamiliar to the physicians of the Middle Ages, and it was only in the sixteenth century that naturalists and physicians again began to investigate the changing aspects of organic life, including the life of man, in various quarters of the globe.

That in these countries but little attention was given to the

subject is evident from the antiquity and popularity of the proverb, "A green Christmas makes a fat churchyard." Even Sydenham stated<sup>1</sup> that a prevailing epidemic ceased on the approach of winter—a statement which is no doubt true in the case of Asiatic cholera, but is of by no means universal or even common application. On the whole, however, Sydenham's observations on the dependence of disease on season are accurate, and well worth perusal.

The first modern paper on Weather and Disease was a communication made to the Royal Society in 1797 by Dr. William Heberden, jun., F.R.S., on the "Influence of Cold on the Health of the Inhabitants of London."<sup>2</sup> The author showed that a difference of above 20° F. between the mean temperatures in London in January, 1795, and that in the same month in 1796—the former being an excessively cold month, and the latter an equally mild one—caused the deaths in January, 1795, to exceed those in January, 1796, by 1,352.

In my remarks on the influence of season and weather on disease, I shall confine myself almost exclusively to three meteorological factors—*mean temperature, rainfall, and humidity*. Of these the first is the most important, as it is, in truth, the resultant of many other factors. In the following chapters we shall consider the influence of season and weather upon some of the principal acute infective diseases.

### 1. *Influenza.*

On February 28, 1890, I read a paper before the Royal Academy of Medicine in Ireland on the "Influenza Epidemic of 1889-90, as observed in Dublin." The two earliest cases of the disease which came under my notice dated from Thursday and Friday, December 5 and 6, 1889, respectively. The outbreak was at its height in the first half of January, 1890—a month which proved one of the sickliest ever experienced within living memory. The whole "Epidemic Constitution"—to use Sydenham's classical phrase—was changed for the worse; the power of resisting disease was lessened; and extreme languor and prostra-

<sup>1</sup> Swan's *Sydenham*, p. 9. 1769.

<sup>2</sup> *Philosophical Transactions*, vol. lxxxvi., No. 11.

tion passed over the population like a pandemic. Towards the close of January the epidemic waned, but in the middle of February there was a recrudescence of it. The duration of the outbreak was practically eleven weeks. In Dublin, while the mean temperature of the first two weeks of the epidemic period was about equal to the average, a remarkable excess of temperature afterwards set in, lasting for at least five weeks, and culminating in the second and third weeks of the new year, the mean temperatures of which were no less than  $7.5^{\circ}$  and  $7.9^{\circ}$  F. respectively above the average. Now, if any one fact has been established in relation to the winter death-rate in Dublin, it is that the deaths from all causes, and particularly from diseases of the respiratory organs, such as bronchitis and pneumonia, vary in number inversely with the temperature. If the thermometer is high in winter, the death-rate is moderate or low; if the thermometer is low, the death-rate is high.

For example, the mean temperature of the first six weeks of 1881 was only  $35.6^{\circ}$  F., or  $5.4^{\circ}$  F. *below* the average. The mean weekly number of deaths from all causes in that period were  $40.1$  *above* the average in a population of 350,000; and the mean weekly number of deaths from diseases of the respiratory organs were  $29.1$  *above* the average. On the other hand, in 1884 the mean temperature of the first six weeks was  $45.1^{\circ}$  F., or  $4.1^{\circ}$  F. *above* the average. The mean weekly number of deaths were  $37.2$  *below* the average, while the mean weekly number of deaths from respiratory diseases were  $19.2$  *below* the average.

And now we come to the opening six weeks of 1890, when the mean temperature shows an excess comparable with that of 1884—it was  $44.2^{\circ}$  F., or  $3.2^{\circ}$  F. above the average, and only  $0.9^{\circ}$  F. below the value for 1884. Under these circumstances, a low rate of mortality from all causes, and especially from respiratory diseases, was to have been looked for. But how different were the facts! The mean weekly number of deaths were  $60.8$  *above* the average— $285.0$  against  $224.2$ . The mean deaths from respiratory diseases were  $40.0$  *above* the average— $98.7$ , against  $58.7$ . The mean weekly deaths from bronchitis were  $65.0$ , compared with the average,  $42.4$ ; while the mean weekly deaths from pneumonia were  $23.3$ , compared with an average of  $8.6$ .

It is of interest to observe that, whereas the deaths referred to bronchitis were only 53 per cent. in excess of the average, those referred to pneumonia were no less than 171 per cent. in excess.

The prime cause of this heightened death-rate at the beginning of 1890 was manifestly the epidemic of influenza, which proved more pernicious to the population of Dublin than the extreme cold of January, 1881.

But the incidence of the outbreak in a winter month was only accidental. Recent experiences confirm Hirsch's statement that influenza has prevailed in all seasons of the year, in all climates, independently of telluric conditions, and under the most various states of the weather—high and low temperature, steady and changeable weather, much or little atmospheric humidity. There is not the slightest ground for assuming a causal relation between the production of influenza and certain states of the barometer. Hirsch gives a table embracing 125 epidemics or pandemics, which ran their course independently of one another; and of these outbreaks, 50 are shown to have begun in winter (December to February), 35 in spring (March to May), 16 in summer (June to August), 24 in autumn (September to November). Certainly winter comes out very decidedly as the season of the year most favourable to the setting up of the disease, but we must remember that an epidemic, once developed, runs its course equally through all seasons of the year, of which fact the pandemics of 1580, 1781-82, 1831, 1832-33, 1836-37, are striking illustrations.

We may conclude, then, that the prevalence of this strange disease is absolutely independent of season and weather—a fact which distinguishes influenza from epidemic bronchial catarrh.<sup>1</sup> “Et tempore frigidiori et calidiori, et flante tam Austro quam Borea, et pluvioso et sereno cœlo, peragravit hasce omnes Europæ regiones, et omnia loca indiscriminatim.”<sup>2</sup> As Morgagni says, “Tempestate frigidâ et siccâ, cœlo die noctuque sereno.”

<sup>1</sup> Hirsch. *Handbook of Geographical and Historical Pathology*, vol. i., p. 26. New Sydenham Society. 1883.

<sup>2</sup> Petrus Salius Diversus, cited by Dunning (*Medica' and Physica' Journal*, vol. x., p. 43), and quoted by Dr. Thomas Hancock in an excellent article on Influenza in the second volume of the *Cyclopædia of Practical Medicine*, published in 1833.



## 2. Cholera.

That cholera tends to prevail in the warmer months of the year is sufficiently borne out by the history of the disease. In Table X. on p. 414 are given the deaths from the disease by months in some of the great epidemics of late years, and the figures speak for themselves. In one case—that of Limerick, 1849—we meet with an early spring epidemic, and in January of the same year a large mortality from cholera prevailed in England. But these are only exceptions. If from the totals we omit the Paris outburst of April, 1832, in which city the epidemic kindled into flame for the second time in July of that year, we have an increasing series of deaths from February to September, and a decreasing series from the last-named month to December.

“Real epidemics of cholera,” writes Professor Faye,<sup>1</sup> “in the more rigorous season of winter have very seldom occurred, while sporadic cases have very frequently shown themselves even in winter. At Breslau a winter epidemic prevailed in 1848-49, continuing from October till March, with the same fatality as had characterised summer epidemics at the same place; and at St. Petersburg, as in several of the districts of Russia, cholera has prevailed in winter, although to a far less degree than in summer, so that the Russian physicians have often declared that the disease is prevalent in the winter quarter. At Bergen, in Norway, the epidemic of 1848-49 was also a winter epidemic. It is therefore not altogether without reason that cholera has been stated to observe no season; but if we take into consideration both the relative infrequency of its appearance in winter, and its impaired virulence under intense degrees of cold, this assertion as to the compatibility of the disease with a winter temperature experiences a very important limitation. Perhaps the explanation of the matter is not very remote. At Bergen, for example, the winter is often rainy, and the air in proportion mild, so that the freezing of the earth’s surface to any depth does not occur; and the winter of 1848-49 was really of this kind. It

<sup>1</sup> “Om Cholera-Epidemien i Norge i Aaret 1853” (“On the Cholera Epidemic in Norway in the Year 1853”).

TABLE X.—SHOWING THE DEATHS FROM CHOLERA, BY MONTHS, IN SEVERAL EPIDEMICS, SINCE 1832, IN VARIOUS CITIES AND COUNTRIES OF EUROPE.

Months.	England, 1832.	England, 1849.	Paris, 1832.	Paris, 1849.	Dublin, 1849.	Limerick, 1849.	Dublin, 1866.	Sweden, 1834.	Sweden, 1850.	Sweden, 1866.	Christiana, 1833.	Christiana, 1850.	Christiana, 1853.	Christiana, 1866.	Paris, 1892.	Hamburg, 1892.	Totals.
January	614	658	?	?	2	0	0	?	?	0	0	0	0	0	0	0	1,274
February	708	371	?	?	6	6	0	?	?	0	0	0	0	0	0	0	1,091
March	1,519	302	90	573	8	591	1	?	?	0	0	0	0	0	0	0	3,084
April	1,401	107	12,733	1,929	32	143	0	?	?	0	0	0	0	0	0	0	16,345
May	748	327	812	4,509	197	4	1	?	?	0	0	0	0	0	10	0	6,368
June	1,363	2,046	868	8,669	477	1	0	?	?	4	0	0	0	0	19	0	13,647
July	4,816	7,570	2,573	865	314	0	2	30	0	483	0	0	6	0	78	0	16,737
August	8,875	15,872	969	1,382	276	0	74	5,904	209	943	0	0	164	8	211	3,030	37,917
September	5,479	20,379	357	1,142	298	1	270	6,124	213	1,209	0	0	1,356	20	535	4,500?	41,903
October	4,080	4,654	62	115	49	0	508	490	880	508	262	50	60	0	102	100?	11,920
November	802	844	?	?	5	0	273	58	342	30	538	37	11	0	6	2	2,948
December	140	163	?	?	0	0	66	31	87	1	17	0	0	0	16	16	537

is well known also that cholera at St. Petersburg in winter-time is almost exclusively confined to the unhealthy houses, situated on the low and swampy banks of the Neva, belonging to an indigent labouring population ; and, indeed, it is not strange that low-lying and overcrowded cellars, beneath which the soil has scarcely stiffened, with a favourable and confined oven-temperature, should foster the contagion and occasion a constant, though tardy, propagation of the disease. Whether conditions of this kind held at Breslau I am unable to say ; but, in any case, it is certain that violent epidemics during severe winter-frost very rarely, if, indeed, ever, occur."

Professor Faye goes on to say that, while the epidemic (of 1853) was at its worst at Christiania, the atmosphere was steadily warm, and the air, in addition, clear and very still. This continued for about three weeks, during which the daily numbers of cases, which were then at the highest, scarcely varied. At this point of time—the middle of September—the air was set in motion by a strong and stormy north-west wind, and, remarkably enough, the number of cases fell, *next day*, to about one-half. Similarly, at Bergen, during the epidemic of 1848-49, a strong and cold north-easterly gale, supervening on a lengthened period of milder temperature, caused a considerable fall in the number of cholera cases.

In the epidemic of 1866 the acme of mortality from cholera was reached in Dublin about the middle of October, the weather of the preceding week having been continuously *calm, cloudy, foggy, damp, with a very high barometer, and a great deficiency of ozone* (the latter showing a mean value of only 10 per cent. at the Ordnance Survey Office, Phoenix Park).

The decrease in the mortality was consequent on a freshening breeze, and a change of wind from north-east to south-west, a diminution of barometrical pressure, a moderate and continued rainfall, a rise in ozone to 70 per cent., and a gradually falling temperature. The coincidence of a high barometer with a great development of cholera has often been remarked, but striking exceptions are also on record. Keeping in view the fact that heavy rain and a strong breeze are most valuable detergents and disinfectants, it seems probable that the *calm weather* conse-

quent on slight barometrical gradients, so common in anti-cyclonic, or high-pressure systems, has more influence than the mere height of the barometer itself. In December the epidemic died out rapidly, and no death occurred later than the 29th of that month, on which day, it is most interesting to note, the intense frost of January, 1867, was ushered in by a fall of temperature amounting to 15° F. in a few hours.

The meteorological conditions just alluded to, and the influence of season, are to be classed among the *predisposing* causes of cholera. Its *exciting* cause is, of course, the introduction into the human system, and particularly the intestinal canal, of the specific virus or contagium of the disease, the *comma bacillus* of Koch. I thoroughly agree with the late Mr. Ernest Hart when he says, with uncompromising dogmatism: "We may lay aside all pedantry and mystery-talk of 'epidemic constitution,' 'pandemic waves,' 'telluric influences,' 'cholera blasts,' 'cholera clouds,' 'blue mists,' and the like terms of art with which an amiable class of meteorologists have delighted to cloak ignorance. Asiatic cholera is a *filth disease, which is carried by dirty people to dirty places*. Cholera," he adds, "does not travel by air waves or blasts. We can drink cholera and eat cholera, but we cannot 'catch' cholera in the sense in which we catch measles, scarlatina, or whooping-cough. Cholera is carried by men in their clothing and their secretions along the lines of human intercourse. Earlier epidemics of Asiatic cholera took three years to reach us, by caravan and fitful travel, from its Asian home. It comes now not as a pedestrian or a horse-man, but by locomotive and fast steamboat." I believe that cholera is taken precisely as enteric fever is taken—that is, it is most usually swallowed in water, less commonly in milk, or it is eaten in solid food, or, exceptionally, it is inhaled and swallowed with the saliva when a liquid medium containing its virus has evaporated, leaving that virus to be air-borne for a short distance. Further, I am satisfied that cholera, like *cholera nostras* or cholerine, and enteric fever also, becomes much more virulent when the subsoil temperature reaches the critical point of 56° F. at 4 feet below the surface. As this occurs most readily when the level of the subsoil water (German, *Grundwasser*) is



low, the significance of Pettenkofer's theory is at once evident. That veteran sanitarian says in one of his later papers :<sup>1</sup> " The fluctuations in the level of the subsoil water have a meaning for ætiology, only because they are traced back to those primary influences by which air and water are made to share, in varying proportion, the possession of the pores of an impregnated soil. Beyond that they have no significance."

### 3. *Diarrhœal Diseases.*

Under this heading are now included in the third revision of "The Nomenclature of Diseases" of the Royal College of Physicians, London (1906), and in the Reports of the Registrars-General of the several divisions of the United Kingdom, "Dysentery," "Infective Enteritis," "Epidemic Diarrhœa," and "Diarrhœa due to Food."

These propositions may be laid down :

1. In summer and autumn the tendency to sickness and death is chiefly connected with the digestive organs—diarrhœa, dysentery, and simple cholera or cholérine (*cholera nostras*), being the affections which are especially prevalent and fatal during these seasons.
2. In summer and autumn a rise of mean temperature above the average increases the number of cases of, and the mortality from, the diseases named.
3. On the other hand, a cool rainy summer and autumn controls their prevalence and fatality.
4. Diarrhœal diseases are observed to become epidemic when the subsoil temperature at a depth of 4 feet below the surface permanently reaches 56° F. This may therefore be called the "critical temperature." Recent investigations would point to this relation as being a coincidence, and not an ætiological factor, as was supposed by Dr. Ballard.

In Table XI., p. 418, facts are given, which support the first of these propositions. Reference to the last two columns of the table will convince the reader that yearly towards the end of July

<sup>1</sup> *Zeitschrift für Biologie*, Heft vi., p. 527. 1870. Quoted by Hirsch, *loc. cit.*, vol. i., p. 466.

TABLE XI., SHOWING THE AVERAGE AND TOTAL DEATHS FROM DIARRHOEAL DISEASES IN THE DUBLIN REGISTRATION DISTRICT IN EACH OF THIRTEEN FOUR-WEEKLY PERIODS IN THE THIRTY YEARS, 1872-1901, AND THE PERCENTAGE OF THE SAME IN EACH OF THE SAID PERIODS.

Four-Week Periods.	Corresponding Periods in Calendar.	Diarrhoeal Diseases.				
		Average Number of Deaths, 1872-1881.	Average Number of Deaths, 1882-1891.	Average Number of Deaths, 1892-1901.	Total Number of Deaths in 30 Years.	Percentage of the Average Annual Deaths.
I.	Jan. 1 to Jan. 28	12·9	9·2	9·1	312	3·5
II.	Jan. 29 „ Feb. 25	10·9	7·7	8·9	275	3·1
III.	Feb. 26 „ Mar. 25	10·2	8·5	8·2	269	3·0
IV.	Mar. 26 „ Apr. 22	12·9	6·7	8·1	277	3·1
V.	Apr. 23 „ May 20	9·9	7·4	5·8	231	2·6
VI.	May 21 „ June 17	9·7	6·7	7·2	236	2·6
VII.	June 18 „ July 15	10·7	10·4	21·8	429	4·8
VIII.	July 16 „ Aug. 12	24·1	28·2	77·1	1,294	14·5
IX.	Aug. 13 „ Sept. 9	56·1	67·1	97·5	2,207	24·6
X.	Sept. 10 „ Oct. 7	54·9	66·6	68·2	1,897	21·2
XI.	Oct. 8 „ Nov. 4	23·2	31·7	27·0	819	9·2
XII.	Nov. 5 „ Dec. 2	13·6	14·2	12·4	402	4·5
XIII.	Dec. 3 „ Dec. 30	9·6	10·6	9·2	294	3·3
Fifty-two Weeks	{ January 1 to December 30 }	2,587	2,750	3,605	8,942	100·0
Fifty-third Week	{ .. }	{ 1873=2 1879=3 }	{ 1884=3 1890=0 }	1896=4	12	
	General Totals ..	2,592	2,753	3,609	8,954	

or the beginning of August, on an average, diarrhoeal diseases, and particularly cholera, assume epidemic proportions in singular obedience to a law of periodicity, and with all the suddenness of an explosion. Of every 100 deaths from diarrhoeal diseases taking place annually, only 2·6 occur in the four weeks ending June 17, only 4·8 in the four weeks ending July 15. Then the percentage runs up to 14·5 in the next four weeks (ending August 12), and to no less than 24·6 in the period ending September 9. In the *eight* weeks ending October 7, 45·8 of every 100 deaths from diarrhoeal diseases take place. Similarly, in the case of simple cholera, of 100 deaths occurring in the whole

year, only 0·6 takes place in the four weeks ending May 20 ; whereas in the period ending September 9, 26·9 take place, and in that ending October 7, no less than 28·8—55·7 per cent. of the annual mortality in *eight* weeks.

From the curves of mortality given by Dr. A. Buchan and Sir Arthur Mitchell in their paper on “The Influence of Weather on Mortality from Different Diseases and at Different Ages” (*Journal of the Scottish Meteorological Society*, vol. iv., p. 187), it would appear that the diarrhœal and choleraic death-rates rise in London to a yearly maximum about three weeks earlier than in Dublin.

In support of the second and third propositions, we have only to refer to the Reports of the Registrar-General for Ireland for the years 1868 and 1887 (warm, dry years), and for the cold, wet year 1879. The facts may best be thrown into a short tabular statement as follows :

TABLE XII.

Quarter.	1868.			1887.			1879.		
	Mean Temp.	Diarrhœal Deaths.	Choleraic.	Mean Temp.	Diarrhœal Deaths.	Choleraic.	Mean Temp.	Diarrhœal Deaths.	Choleraic.
I.	° F. 44·7	39	0	° F. 41·9	31	2	° F. 39·3	39	0
II.	55·5	22	1	53·1	27	0	49·7	38	0
III.	60·7	289	11	59·3	331	11	56·4	54	1
IV.	45·3	77	0	43·3	71	1	43·8	54	1
	51·6	427	12	49·4	460	14	47·3	185	2

In his Weekly Return of Births and Deaths in Dublin for August 22, 1868, the Registrar-General for Ireland wrote : “The number of deaths from diarrhœa registered during the week amounted to forty-nine, showing an increase of twenty-three on the number registered during the week preceding, and being thirty-five more than the average deaths from this disease in the corresponding week of the four previous years.” In his return for the corresponding week in 1879, the Registrar-General observed : “Owing chiefly to the low mortality from diarrhœa, the number of deaths from zymotic diseases is considerably

under the average for the thirty-fourth week of the last ten years." As a matter of fact, only *one* death from diarrhœa was registered in the whole Dublin Registration District in that week, and the largest number of deaths from the disease registered in any week during 1879 was eight in the week ending Saturday, September 13. A more striking contrast can hardly be imagined than that between the epidemic prevalence of diarrhœa in the very warm season of 1868 and its absence in the extremely cool summer of 1879.

The year 1868 may be cited as an example of an unusually *warm year*. There was an almost complete absence of frost, and during ten out of the twelve months the mean temperature was above the average: the excess varying from  $0.5^{\circ}$  F. in January to  $3.8^{\circ}$  F. in March—the warmest March within the twenty years now under discussion—namely, 1868-1887. October and November were cold, the deficit of temperature amounting to  $2.0^{\circ}$  and  $1.1^{\circ}$  respectively. Notwithstanding this, the mean temperature of the whole year was  $51.5^{\circ}$ , compared with an average of  $49.7^{\circ}$  (excess= $1.8^{\circ}$ ). A remarkable drought prevailed from the last week in April to August 10, when a tropical rainfall occurred. During this period of nearly three and a half months only 2.797 inches of rain fell in the city. On six occasions during the summer of this year the thermometer rose to  $80^{\circ}$  in the shade in Dublin—the highest readings of all being  $86^{\circ}$  on July 15, and  $85^{\circ}$  on July 21. On August 1 the maximum was  $82^{\circ}$ , and even as late as September 6 the high reading of  $77^{\circ}$  was noted.

In marked contrast to 1868, and as an instance of a *cold year*, 1879 stands out in bold relief. The annual mean temperature was only  $47.3^{\circ}$  F.—that is,  $2.4^{\circ}$  below the average ( $49.7^{\circ}$ ). *Every* month was colder than usual—the deficit of mean temperature ranging from  $6.3^{\circ}$  in January,  $3.1^{\circ}$  in April,  $3.2^{\circ}$  in July, and  $4.0^{\circ}$  in December to  $1.2^{\circ}$  in November. Only in October was the mean temperature,  $49.7^{\circ}$ , slightly in excess of forty years' average,  $49.5^{\circ}$ . Curiously enough, these last-named months were relatively the coldest in the warm year 1868. There was a singular absence of summer heat in July and August; in each of these months the shade temperature



exceeded 70° F. on one day only in Dublin, and on nine days in July it did not reach 60° F. The low temperature was accompanied with—to some extent depended upon—a continuous rather than a heavy rainfall. During the six months ending September 30, rain fell on 125 out of 183 days—that is to say, on two out of every three days. The amount of cloud during this cold, damp, sunless year was 7·5 per cent. over the average. The cold weather, which persisted almost throughout 1879, set in first on October 21, 1878. This period of low temperature had probably not been paralleled for intensity and duration within the nineteenth century.

In their classical paper already quoted, Dr. Buchan and Sir Arthur Mitchell speak of “the close and direct relations which the progress of mortality from these (diarrhœal) diseases bears to temperature. This relation is seen in the startling suddenness with which they shoot up during the hottest weeks of the year, and the suddenness, equally startling, with which they fall on the advent of colder weather.” The authors point out that the death-rate curves for diarrhœa and cholera rise and fall about a month earlier than do those for dysentery and epidemic cholera. The annual phases of the former diseases are, in other words, about a month earlier than those of the latter. For all four diseases, the curves are reproduced in all their essential features from year to year. In very hot summers the numbers of deaths are enormously increased, and in cold summers, such as 1860, the deaths from bowel complaints are correspondingly few.

The fourth proposition was first advanced by Dr. Edward Ballard, in his elaborate Report to the Local Government Board for England upon the causation of the annual mortality from “Diarrhœa,” which is observed principally in the summer season of the year.<sup>1</sup> That a *high atmospheric temperature* conduces to a high diarrhœal mortality, and a low atmospheric temperature to a low diarrhœal mortality, Dr. Ballard admits. “It is,” he says, “an established fact which no one can dispute.” But his inquiry showed that the influence thus exerted is *not a direct influence*, except in so far as it affects also infant mortality from

<sup>1</sup> *Supplement in Continuation of the Report of the Medical Officer for 1887. Seventeenth Annual Report of the Local Government Board, 1887-88.* London: Eyre and Spottiswoode, 1889. Quarto. P. 1 *et seq.*

all causes. *Rainfall*, again, exerts an influence on diarrhœa, but apparently not equally in all periods of the diarrhœal season. The diarrhœal mortality is greater in dry, less in wet seasons. But here again the influence exerted is not direct (*e.g.*, by a washing of the atmosphere, so to speak), but indirect—namely, by its effect mainly in preventing the rise and (probably to a less extent) in hastening the fall of the temperature of the earth.

*Wind* and *comparative calm* affect the diarrhœal mortality. Other things being equal, calm in the diarrhœal season promotes it, and high winds tend to lessen it.

But *soil* and the *temperature of the soil* are far more important predisposing causes of diarrhœal diseases. Their prevalence and fatality is low in dwelling-houses built on a foundation of *solid rock*. Deep and wide and frequent fissuring of the rock in a town, or superficial alternations of rock with looser material, modify this immunity. On the other hand, a *loose soil*, more or less freely permeable by water and by air, is a soil on which diarrhœal mortality is apt to be high. Of all natural soils, sand and surface mould to a considerable depth are “the most diarrhœal.” Gravel varies in its relation to diarrhœal mortality according to its texture: fine, sand-like gravel predisposes to diarrhœal prevalence; coarse, rock-like gravel is more wholesome. Clay soils do not in themselves favour diarrhœa. A soil which is a mixture of clay, sand, and stones (commonly called a “marl”), is apparently favourable or unfavourable to diarrhœal mortality in proportion as it is loose and permeable on the one hand, or plastic on the other. The presence of much *organic matter* in the soil renders it distinctly more conducive to high diarrhœal mortality than it otherwise would be. Hence, dwellings built upon made ground, the refuse of towns, or the site of market-gardens, are unwholesome. And, of course, a sewage-soaked subsoil is most unwholesome and dangerous. *Excessive wetness* and *complete dryness* of the subsoil appear to be alike unfavourable to diarrhœa. *Habitual dampness*, which is not sufficient to preclude the free admission of air to the interstices of the subsoil, favours diarrhœal prevalence.

Dr. Ballard, however, considers that the *Temperature of the Soil* is a far more effective element in the causation than any of

the meteorological factors just mentioned. He constructed for London and many other towns in the kingdom a large number of charts, showing week by week for many years the earth temperature at a depth of 1 foot from the surface and at a depth of 4 feet also, each chart showing in addition the diarrhœal mortality of the corresponding weeks. The general result shown by these charts is as follows :

*α.* The summer rise of diarrhœal mortality does not commence until the mean temperature recorded by the 4-foot earth thermometer has attained somewhere about 56° F., no matter what may have been the temperature previously attained by the atmosphere or recorded by the 1-foot earth thermometer.

*β.* The maximal diarrhœal mortality of the year is usually observed in the week in which the temperature recorded by the 4-foot earth thermometer attains its mean weekly maximum.

*γ.* The decline of the diarrhœal mortality coincides with the decline of the temperature recorded by the 4-foot earth thermometer, which temperature *declines* very much more slowly than the atmospheric temperature, or than that recorded by the 1-foot earth thermometer. The epidemic mortality may in consequence continue (although declining) long after the last-mentioned temperatures have fallen greatly, and may extend some way into the fourth quarter of the year.

*δ.* The atmospheric temperature and that of the more superficial layers of the soil exert little, if any, influence on the prevalence of diarrhœa until the temperature recorded by the 4-foot earth thermometer has risen to 56° F. Then their influence is apparent, but it is a subsidiary one, notwithstanding the statement made by Dr. August Hirsch that the summer diarrhœa of children makes its appearance as an epidemic only in those districts whose average temperature for the day in the warm season is rather more than 15° C. (59° F.).<sup>1</sup>

It is interesting to notice that in an excellent article on "Cholera Infantum," which appeared in the *Medical Annual* for 1893, Dr. E. Meinert, of Dresden, entirely adopts Dr. Ballard's views as to the meteorological ætiology of this disease, while he

<sup>1</sup> *Handbook of Geographical and Historical Pathology*, vol. iii., p. 379. New Sydenham Society. 1886.

also expresses his entire concurrence with Dr. Ballard's statement that *density of buildings*, whether dwelling-houses or other, upon area—quite apart from *density of population* upon area—promotes diarrhœal mortality to a remarkable degree, particularly because crowding together of buildings of whatever sort restricts and offers an impediment to the free circulation of air. Dr. Edward W. Hope, the Medical Officer of Health for Liverpool, has investigated the influence of the *mode of feeding* of young infants, upon the prevalence and fatality of diarrhœa, and arrives at the following conclusions :<sup>1</sup>

1. Infants fed solely from the breast are remarkably exempt from fatal diarrhœa.
2. Infants fed in whatever way with artificial food, to the exclusion of breast milk, are those who suffer most heavily from fatal diarrhœa.
3. Children fed partially at the breast, and partially with other kinds of food, suffer to a considerable extent from fatal diarrhœa, but very much less than those who are brought up altogether by hand.
4. As regards the use of "the bottle," it is decidedly more dangerous than artificial feeding without the bottle.

In relation to this part of the subject, Dr. Ballard's observations go to show that the circumstances of *food-keeping*, of its exposure to telluric emanations (*e.g.*, in underground cellars), or to emanations from accumulations of domestic filth, etc. (*e.g.*, when kept in pantries, etc., to which such emanations have more or less free access), tends to render it liable to produce diarrhœa, especially where the storing place of food is dark, and not exposed to currents of air.

Dr. Ballard believes that a working hypothesis, or provisional explanation, that would best accord with the whole evidence in his possession bearing on the production of epidemic diarrhœa, may be stated as follows :

1. The essential cause of diarrhœa resides ordinarily in the superficial layers of the earth, where it is intimately associated

<sup>1</sup> Cf. Dr. Ballard's Report, p. 6.



with the life processes of some micro-organism not yet detected, captured, or isolated.

2. The vital manifestations of such organism are dependent, among other things, perhaps principally, upon conditions of season and on the presence of dead organic matter which is its pabulum.

3. On occasion, such micro-organism is capable of getting abroad from its primary habitat, the earth, and having become air-borne obtains opportunity for fastening on non-living organic material, and of using such organic material both as nidus and as pabulum in undergoing various phases of its life-history.

4. In food, inside of as well as outside of the human body, such micro-organism finds, especially at certain seasons, nidus and pabulum convenient for its development, multiplication, or evolution.

5. From food, as also from the contained organic matter of particular soils, such micro-organism can manufacture, by the chemical changes wrought therein through certain of its life processes, a substance which is a *virulent chemical poison*.

6. This chemical substance is, in the human body, the material cause of epidemic diarrhoea.

To the foregoing we have only to add Dr. Meinert's words: "The poison, or a combination of poisons, appears to work upon the medulla oblongata, for there lies the centre for intestinal secretion, vomitings, convulsions, respiratory and vaso-motor phenomena."

Duval and Bassett, working at the Mount Wilson Sanatorium, discovered, in the dejecta of children suffering from summer diarrhoea, a bacillus apparently identical with the organism shown by Shiga (in 1898) to be the cause of epidemic dysentery in Japan.<sup>1</sup> In 1903 the Rockefeller Institute research showed that this organism was present in a large number of cases of so-called "summer diarrhoea." "The laboratory studies," writes Professor Osler, "of Martini and Lentz, Flexner, His, Parke, and others, indicate that there is a group of closely allied forms of bacilli differing slightly from the original Shiga\_bacillus

<sup>1</sup> Osler, *The Principles and Practice of Medicine*, p. 243. Seventh edition, 1909.

in their action on certain sugars and in agglutinating properties. The type of organisms most frequently associated with the diarrhœas of children belongs to the so-called 'acid type,' and, unlike the Shiga cultures, ferments mannite with acid production."<sup>1</sup>

In the *British Medical Journal* for 1906 and 1907,<sup>2</sup> Mr. Harry de Riemer Morgan, Ernest Hart Memorial Scholar, reported on the "Bacteriology of the Summer Diarrhœa of Infants." The result of his investigations was the discovery of several different organisms instead of a single specific form. But he did discover a bacillus, not hitherto described so far as he could ascertain, which appeared to him entitled, in the absence of further knowledge, to be regarded as a factor, perhaps the most important factor, in the causation of the disease.

Messrs. Orr, Williams, Murray, and Rundle, working upon material from the Liverpool City Hospital at Fazakerley, have found yet another microbe in a case of epidemic diarrhœa, and they denote it as the "Bacillus F."<sup>3</sup> Their summary of conclusions is as follows: "The Bacillus F. was obtained from a case of epidemic diarrhœa. By its cultural reactions it is readily differentiated from the *Bacillus typhosus*. The absence of indol formation separates it from Morgan's No. 1 Bacillus. The presence of well-marked motility is sufficient to distinguish it from Morgan's Bacilli Nos. 3 and 4, and from the dysentery bacilli. The agglutination reactions show that there is a relationship between this organism and the *Bacillus typhosus* and the paratyphoid Bacillus B. The Bacillus F. is able to produce diarrhœa in animals, and can be recovered from their stools. We believe, therefore, that it may be an agent in the production of epidemic diarrhœa. During the summer of 1908 we have further investigated this disease, and find that we have obtained a positive agglutination reaction, varying from 1 in 25 to 1 in 100 in nearly half the cases tested against the Bacillus F. The specificity of this reaction we cannot yet affirm, but we hope later to publish a further report on the material obtained during the past summer."

<sup>1</sup> *Op. cit.*, p. 505.

<sup>2</sup> *British Medical Journal*, p. 16. July 6, 1907.

<sup>3</sup> Abstract in *The Journal of Clinical Research*, May, 1909.

Of late years much attention has been paid to the part which the common house-fly plays in the transmission of infectious material to articles of food, and thereby in the causation of tuberculosis, epidemic diarrhœa, enteric fever, and cholera. Among the British authorities on this subject are Professor E. Klein;<sup>1</sup> Dr. James T. C. Nash,<sup>2</sup> M.O.H. for Co. Norfolk; Dr. V. J. Glover,<sup>3</sup> of Liverpool; Mr. Robert Newstead, Liverpool School of Tropical Medicine; and Mr. Ernest E. Austen.<sup>4</sup> The last-named authority, in an article on "Blood-Sucking and Other Flies," published in Part II. of the second volume of Allbutt's *System of Medicine*,<sup>5</sup> refers the reader to a memoir by Dr. G. H. F. Nuttall, "On the Rôle of Insects, Arachnids, and Myriapods as Carriers in the Spread of Bacterial and Parasitic Diseases of Man and Animals," which was published in the eighth volume of the *Johns Hopkins Hospital Reports*. He also states that information on this subject will be found in L. O. Howard's "Contribution to the Study of the Insect Fauna of Human Excrement (with especial Reference to the Spread of Typhoid Fever by Flies)," in the second volume for 1900 of the *Proceedings of the Washington Academy of Science*.

Mr. Austen holds that certain flies, while incapable of sucking blood, are nevertheless, in some instances, important agents in the dissemination of such diseases as cholera and enteric fever. In these cases the flies act as mechanical carriers of bacilli or other infective matter ("fomites"), and the effect is produced chiefly by the contamination of food. The species concerned are those most closely associated with man, and of these the common house-fly (*Musca domestica* Linn.) is the most important.

In December, 1907, Dr. Daniel D. Jackson, S.B., reported to the Committee on Pollution of the Merchants' Association of New York, on the pollution of the harbour of that great city as a menace to health by the dissemination of intestinal diseases through the agency of the common house-fly.

The investigations upon which this important sanitary report

<sup>1</sup> *British Medical Journal*, October 17, 1908.

<sup>2</sup> Trans. Epidem. Society, London, 1903. *Lancet*. 1904.

<sup>3</sup> *Lancet*, September 5, 1908.

<sup>4</sup> *Journal of the Royal Army Medical Corps*, June, 1904.

<sup>5</sup> London: Macmillan and Co., 1907. P. 185.

is based, were carried out during the summer months of 1907, under the immediate direction of Dr. Jackson, assisted by a number of observers. They proved that the water front of Greater New York was much contaminated by human excreta. It was found that at many points sewer outfalls had not been carried below the low-water mark, in consequence of which the solid matters from the sewers were exposed on the shores. It was also shown that deposits of this nature may, and did actually, become a source of typhoid fever and certain intestinal diseases through the agency of flies. It is this last point which lends a special value to the New York Harbour Pollution Report.

The large amount of work which was carried on during the summer of 1907 was divided into two parts—first, a thorough inspection of all sources of contamination throughout the entire water front of the city; second, a study of the prevalence and distribution of flies by fly-cages distributed in all parts of the city in order to demonstrate what proportion of the intestinal diseases in the city were contracted by means of these insects.

Examinations made of flies at the beginning of the season directly after hibernation showed that many of them carried only a few bacteria and moulds, and little or no faecal matter. Like examinations made later in the year showed the presence of numerous animal and vegetable parasites, faecal matter in abundance, large numbers and many kinds of germs. In some cases an individual fly carried as many as 100,000 faecal bacteria on its legs, in its mouth, and on its body. Over 98 per cent. of the flies found in dwelling-houses belong to one species—namely, that known as the common house-fly (*Musca domestica*). The activity of these flies extends over a very few weeks of the summer, after which most of them perish by cold or are killed by moulds and other parasites. The few which hibernate and come out in the spring are observed, in the climate of New York, about the middle of June.

These flies begin to lay eggs soon after their emergence, preferably in horse dung, but also in human excreta and in decaying animal and vegetable matter. The eggs hatch in from six to eight hours. The larvæ are white pointed maggots. They grow rapidly, cast their skins twice, and, under favourable conditions, reach full size in four or five days. The outer skin then becomes



hard, swells up, and turns dark brown in colour. Within it the true pupa is found. In about five days the adult fly issues forth from a round hole in the anterior end of the brown pupa-case. The total time required for a single generation is about ten days, and the number of generations during the summer season, stated by some authorities to be as many as twelve, is probably about one-half that number in New York. The number of eggs laid by each female fly during the season is about 1,000.

A table is given by Dr. Jackson showing the total deaths by weeks from diarrhoeal diseases in New York during the summer of 1907, together with the general prevalence of flies in that city. This table proves that the time of appreciable prevalence of flies in 1907 was the period from July 1 to September 30. By far the greatest number of flies were caught in cages in the weeks ending July 27 and August 3. It will also be seen from the table that deaths from intestinal complaints rose above normal at the same time at which flies become prevalent, culminated at the same high point, and fell off with slight "lag" at the time of the gradual falling off of the prevalence of the insects. A secondary rise of flies in September is reflected in a fresh rise in the number of deaths from intestinal diseases. Dr. Jackson very properly points out that the comparative immunity from diarrhoea of breast-fed babies and the frequent occurrence of diarrhoeal diseases among artificially-fed babies point strongly to the food as a medium of transmission. Much of this actual infection is, in his opinion, undoubtedly due to flies. He adds: "There is crying need for better sanitation on our dairy farms." Of one individual fly, captured on South Street, and found on examination to be carrying in his mouth and on his legs over one hundred thousand (100,000) faecal bacteria, Dr. Jackson says: "He had been walking over human excreta on the water front, and was on his way to the nearest milk-pitcher."

This remarkable Report is illustrated by a number of maps, diagrams, photographs, and tables.

Dr. Glover<sup>1</sup> agrees with those writers who have remarked the prevalence of summer diarrhoea with a high ground-air temperature, particularly when occasional showers alternate with prolonged high atmospheric temperature. These conditions

<sup>1</sup> *Lancet*, p. 717. September 5, 1908.

favour the growth of micro-organisms. Dr. Glover's theory is that, whilst the female fly walks over the nauseous material in which she lays her eggs and during her act of oviposition, multitudes of micro-organisms, and pre-eminent among them the *unknown one* of infantile summer diarrhœa, adhere to the moist sucker-like terminations of the hairs on the pulvilli of the fly's legs. The house-fly loves warmth and also food delicacies, and so it haunts our homes, frequenting the sugar-bowl, the jam-pot, and the milk-jug. In this way it carries the contagion. Babies also often sleep with their mouths open and smeared with milky saliva. To such a mouth the fly seems to be attracted, and often will venture slightly inside the lips, so infecting the child, even if breast-fed, with the poison of summer diarrhœa.

The Right Hon. John Burns, President of the Local Government Board for England, in 1908 authorised an investigation into the possible carriage of infection by flies, under the general supervision of Dr. S. Monckton Copeman, F.R.S., in co-operation with Dr. G. H. F. Nuttall, F.R.S., Professor of Biology in the University of Cambridge. A Preliminary Report<sup>1</sup> of this investigation contains the following: (1) How to distinguish the more important species of flies found in houses—namely, the common house-fly, *Musca domestica*; the lesser house-fly, *Homalomyia canicularis*; the blue-bottle, *Calliphora erythrocephala*; and the *Muscina stabulans*, by Mr. E. E. Austen, of the British Museum. (2) Mr. Austen's notes on flies examined during 1908. (3) Mr. Jepson's report on the breeding of the common house-fly during the winter months. Mr. Jepson shows by a series of experiments that flies, provided the temperature is suitable, may go on breeding in winter. He gives the duration of the various stages at an average temperature of 70° F., as follows: The eggs hatch in twenty-four hours, the larval period occupies eleven days, the pupal stage on an average ten days. He concludes that much might be done to reduce the number of, or even to exterminate, flies, if isolated colonies living in certain warm places through the winter months were carefully sought out and destroyed.

<sup>1</sup> *Reports to the Local Government Board on Public Health and Medical Subjects. New Series. No. 5. Preliminary Reports on Flies as Carriers of Infection.* London: Wyman and Sons, Limited. Edinburgh: Oliver and Boyd, Tweedale Court. Dublin: E. Ponsonby. 1909.

## CHAPTER XXVIII

### ACUTE INFECTIVE DISEASES (*continued*)

#### 4. *Enteric Fever.*

It is fitting that this disease should be taken next in order after cholera and the diarrhoeal diseases, to which it presents so many points of analogy.

*Season.*—Enteric fever is most prevalent in *autumn* and *early winter*, hence the names by which it is often described in America, “*Autumnal*” or “*Fall Fever*” (Austin Flint). The exciting cause of the disease seems to be called into action only, as Murchison says, “by the *protracted* heat of summer and autumn, while it required the *protracted* cold of winter and spring to impair its activity or to destroy it.” An examination of the Returns of the Registrar-General for Ireland shows that enteric fever exhibits, as the summer rolls by, a decided tendency to increase in Dublin at an earlier period than typhus. This is, no doubt, partly due to the fact that the secondary phenomena of enteric fever are generally developed in connection with the digestive system, acute and infective diseases of which system increase towards autumn.

The diagram on p. 432 (Fig. 95) is reproduced from the Annual Summary of the Registrar-General for England for 1890.

*Temperature and Moisture.*—Hot, dry, calm summers increase the prevalence of enteric fever, which is less frequent in cold, wet, stormy seasons. Warm, damp weather, however, predisposes to the disease. Floods occurring in badly drained localities may impregnate sources of drinking-water with the germs of enteric fever, and so lead to its outbreak.

*Soil and Underground Water.*<sup>1</sup>—Professor von Pettenkofer

<sup>1</sup> An excellent résumé of various papers on this subject in the *Zeitschrift für Biologie* will be found in the *Ugeskrift for Læger*, Copenhagen, January 30, 1869. A translation by my father, Dr. W. D. Moore, appeared in the *Dublin Journal of Medical Science*, vol. xlvii., p. 497, May, 1869.

and Professor Buhl, of Munich, have shown that when the subsoil water in that city (as measured by the depth of water in the surface wells) is falling, the number of cases of enteric fever increases ;

when the water level is rising, the number of cases diminishes. Liebermeister and Buchanan suppose that these observations simply illustrate the mode in which the disease is communicated by means of drinking-water. When the subsoil water is low, any noxious matters in it accumulate and acquire a greater virulence.

In the case of an outbreak of enteric fever at Terling, Essex, in December, 1867, the late Sir Richard Thorne Thorne, then an Inspector, and afterwards Medical Officer, of the Local Government Board of England, found that the disease had broken out with great severity precisely when the wells were high.<sup>1</sup>

Two or three years after the introduction of the Vartry Water Supply into Dublin, in 1868, a serious local outbreak of enteric fever took place in Trinity College, Dublin. It was confined to the resident water-drinkers in the College. An inquiry was instituted into the cause of the outbreak, the Rev. Dr. Haughton,

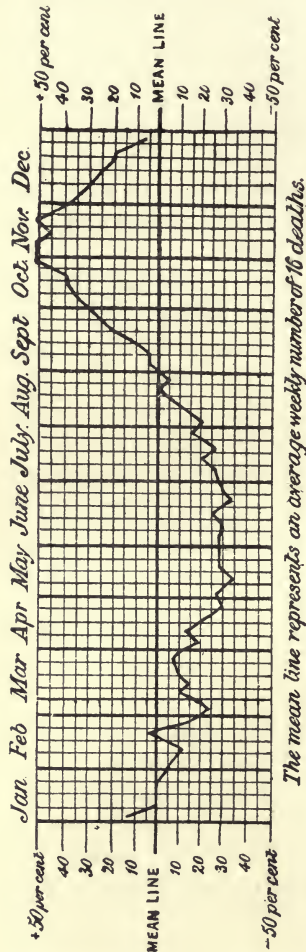

FIG. 53.—MORTALITY CURVE OF ENTERIC FEVER (22 YEARS, 1869-90).  
The mean line represents an average weekly number of 16 deaths.

F.R.S., Fellow of Trinity College, Dr. Apjohn, F.R.S., then Professor of Chemistry in the University of Dublin, and Mr. Dowling, then Professor of Engineering in the University, being appointed to act as Commissioners by the Rev. H. Lloyd, D.D.,

<sup>1</sup> *Tenth Report of the Medical Officer of the Privy Council*, p. 51. 1868.



at the time Provost of Trinity College. It was found that, owing to high tides in the River Liffey, and the accumulation of water in the subsoil, in consequence partly of the disuse of the pumps after the introduction of the Vartry water, and partly of the leakage of the Vartry water itself from defective house-drains, the foul subsoil water had overflowed into and contaminated the well within the College precincts from which the drinking-water in use in the College was drawn. Ever since that time the level of the subsoil water in Trinity College has been kept low by steam pumping, at a cost of about £300 per annum, with the result that within the past forty years no indigenous outbreak of enteric fever has occurred amongst the residents in the College.

TABLE XIII.—SHOWING THE TOTAL NUMBER OF DEATHS FROM ENTERIC FEVER IN THE DUBLIN REGISTRATION DISTRICT IN EACH OF THIRTEEN FOUR-WEEKLY PERIODS IN THE THIRTY YEARS 1872-1901<sup>1</sup>; THE AVERAGE YEARLY NUMBER OF DEATHS FROM THIS FEVER IN THE DECENNIAL PERIODS 1872-81, 1882-91, and 1892-1901 RESPECTIVELY; AND THE PERCENTAGE OF THE TOTAL MORTALITY FROM THE SAME FEVER IN EACH OF THE SAID PERIODS.

Four-Week Periods.	Corresponding Periods in Calendar.	Average Number of Deaths, 1872-81.	Average Number of Deaths, 1882-91.	Average Number of Deaths, 1892-1901.	Total Number of Deaths in 30 Years.	Percentage of the Average Annual Deaths.
I.	Jan. 1 to Jan. 28	16·1	12·1	15·1	433	8·9
II.	Jan. 29 „ Feb. 25	16·0	10·8	11·2	380	7·9
III.	Feb. 26 „ Mar. 25	14·6	13·2	11·7	395	8·2
IV.	Mar. 26 „ Ap. 22	12·3	9·8	8·9	310	6·4
V.	Ap. 23 „ May 20	14·3	9·6	8·2	321	6·6
VI.	May 21 „ June 17	8·7	8·1	7·1	239	4·9
VII.	June 18 „ July 15	10·6	8·6	6·9	261	5·4
VIII.	July 16 „ Aug. 12	9·2	7·9	6·4	235	4·9
IX.	Aug. 13 „ Sept. 9	10·7	10·1	11·2	320	6·6
X.	Sept. 10 „ Oct. 7	14·3	10·9	18·1	433	8·9
XI.	Oct. 8 „ Nov. 4	12·7	19·7	20·3	527	10·9
XII.	Nov. 5 „ Dec. 2	15·9	17·1	17·0	500	10·3
XIII. <sup>1</sup>	Dec. 3 „ Dec. 30	13·8	20·2	14·9	489	10·1
	Totals ..	1,692	1,581	1,570	4,843	100·0

<sup>1</sup> The thirteenth period included five weeks in 1873 (no deaths), 1879 (2 deaths), 1884 (7 deaths), 1890 (7 deaths), and 1896 (3 deaths). These 19 deaths raise the periodic averages from 13·6 to 13·8 in 1872-81, from 18·8 to 20·2 in 1882-91, and from 14·6 to 14·9 in 1892-1901; and the yearly averages from 169·0 to 169·2 in 1872-81, from 156·7 to 158·1 in 1882-91, and from 156·7 to 157·0 in 1892-1901.

The preceding table supplies information as to the seasonal mortality from enteric fever in Dublin in the thirty years ending 1901. The facts are drawn from the Reports of the Registrar-General for Ireland. In this table the year is divided into *thirteen* periods of *four* weeks each. In each of the years 1873, 1879, 1884, 1890, and 1896, *fifty-three* weeks are included, in order to bring the Registrar-General's statistics into agreement with the Calendar. In these five additional weeks nineteen deaths from enteric fever were registered, thus raising by so many the number of deaths recorded in the thirteenth four-week period in the table.

The table shows that, allowance being made for a three weeks' illness before death and registration occur, enteric fever increases in prevalence and fatality towards the end of July—that is, with a rise of the subsoil temperature at 4 feet to and above the critical point of 56° F. Its epidemic character becomes pronounced in September, and continues until the close of February, after which the disease becomes less frequent and deadly, reaching its spring minimum at the beginning of May. From this time to the end of June is also the period of its annual minimum, while its annual maximum takes place about the middle of November. These results agree remarkably with the curve for typhoid fever for all ages and both sexes given by Buchan and Mitchell.<sup>1</sup> This is a well-marked curve (they say) resembling the curve for scarlatina in showing the maximal death-rate in October and November, but differing from it in the duration and phases of the minimal period. Scarlatina falls below its average in the beginning of January, typhoid fever not till the last week of February; scarlet fever has its absolute minimum period from the middle of March to the middle of May, typhoid fever from the middle of May to the end of June; scarlet fever begins steadily to rise in the second week of May, typhoid not till the beginning of July, when the heat of summer has fairly set in.

<sup>1</sup> "The Influence of Weather on Mortality," *Journal of the Scottish Meteorological Society*, vol. iv., p. 197.

5. *Typhus Fever.*

Typhus is essentially a disease of winter and spring—that is, of the colder seasons of the year. Among the predisposing causes of this fever, *season* and *atmospheric temperature* are commonly included.

*Season.*—During twenty-three years January and March were the months in which the number of admissions of typhus patients to the London Fever Hospital reached a maximum—the minimum falling in September, August, and July. This distribution was from time to time disturbed by an epidemic, outbreaks of typhus commencing and advancing irrespective of season. An examination of the Registrar-General's (Ireland) returns of deaths from typhus in Dublin, undertaken many years ago, led me to the conclusion that the death-rate from typhus attains its *maximum in January* and its *minimum in September*. The reason for this is not far to seek. Typhus is often intimately related to overcrowding, and affections of the respiratory organs are among its most frequent complications. Hence we should expect to meet with it especially in the colder seasons of the year. Murchison points out that typhus does not always become more prevalent with the commencement of cold weather, nor does it decline immediately on the advent of summer. He correctly infers from this that the increase of typhus in winter and spring is due not so much to the direct effect of cold as to the *continued overcrowding* and *defective ventilation* of the dwellings of the poor in cold weather.

The accompanying table gives the facts relating to the deaths from typhus in Dublin during the thirty years 1872-1901, inclusive (see Table XIV., p. 436).

Apart from our present inquiry, one gratifying circumstance stands prominently out from the figures in the following table, and that is the fact that typhus fever is fast dying out in Dublin. The number of deaths from the disease fell nearly 50 per cent. (49·1)—to 507 from 996—in the second decennium discussed in the table, and as much as 85·2 per cent.—from 507 to 75—in the third decennium.

An analysis of the table proves that the mortality from typhus

reaches a minimum in the ninth and tenth periods—August 13 to October 7; while the minimal death-rate from enteric fever has already occurred in the eighth period—July 16 to August 12; this fever exhibiting, as the summer rolls by, a decided tendency to increase at an earlier period than typhus. The highest percentage death-rates from typhus are met with in the seasons of winter, spring, and early summer—10·4 per cent. of the fatal cases being registered in the second period (January 29 to February 25), and 10·0 per cent. in the fifth period (April 23 to May 20).

TABLE XIV.—SHOWING THE TOTAL NUMBER OF DEATHS FROM TYPHUS FEVER IN THE DUBLIN REGISTRATIO<sup>n</sup> DISTRICT IN EACH OF THIRTEEN FOUR-WEEKLY PERIODS IN THE THIRTY YEARS 1872-1901; THE AVERAGE YEARLY NUMBER OF DEATHS FROM THIS FEVER IN THE DECENNIAL PERIODS 1872-81, 1882-91, AND 1892-1901 RESPECTIVELY; AND THE PERCENTAGE OF THE TOTAL MORTALITY FROM THE SAME FEVER IN EACH OF THE SAID PERIODS.

Four-Week Periods.	Corresponding Periods in Calendar.	Average Number of Deaths, 1872-1881.	Average Number of Deaths, 1882-1891.	Average Number of Deaths, 1892-1901.	Total Number of Deaths in 30 Years.	Percentage of the Average Annual Deaths.
I.	Jan. 1 to Jan. 28	9·0	4·3	1·0	143	9·1
II.	Jan. 29 „ Feb. 25	9·8	5·9	1·0	167	10·6
III.	Feb. 26 „ Mar. 25	8·1	5·4	0·6	141	8·9
IV.	Mar. 26 „ Ap. 22	7·4	5·8	0·7	139	8·8
V.	Ap. 23 „ May 20	10·2	4·8	0·7	157	9·9
VI.	May 21 „ June 17	9·6	3·1	0·4	131	8·3
VII.	June 18 „ July 15	7·1	4·1	0·3	115	7·3
VIII.	July 16 „ Aug. 12	7·5	2·4	0·4	103	6·5
IX.	Aug. 13 „ Sept. 9	4·6	3·4	0·6	86	5·5
X.	Sept. 10 „ Oct. 7	5·1	2·0	0·5	76	4·8
XI.	Oct. 8 „ Nov. 4	6·0	3·4	0·5	99	6·3
XII.	Nov. 5 „ Dec. 2	6·9	2·9	0·3	101	6·4
XIII. <sup>1</sup>	Dec. 3 „ Dec. 30	8·3	3·2	0·5	120	7·6
	Totals ..	996	507	75	1,578	100·0

According to Buchan and Mitchell,<sup>2</sup> the curve for typhus is above the average from January to the beginning of May, and,

<sup>1</sup> The thirteenth period included five weeks in 1873 (4 deaths), 1879 (3 deaths), 1884 (no deaths), 1890 (no deaths), and 1896 (no deaths). These 7 deaths raise the periodic average from 7·6 to 8·3, and the yearly average from 98·9 to 99·6, in 1872-1881.

<sup>2</sup> *Loc. cit.*, p. 197.



with the exception of the hot season of July and the beginning of August, it is below the average from the middle of May to the end of September. It seems probable that the curve has two maxima—the larger in the early months of the year, and the smaller in the height of summer. Buchan and Mitchell's typhus curve is based on only six years' returns of mortality—1869-1874.

*Temperature and Moisture in the Atmosphere* do not seem to have any marked predisposing influence on typhus, notwithstanding the opinion advanced in 1866<sup>1</sup> by Dr. T. W. Grimshaw, afterwards Registrar-General for Ireland, that a warm moist state of the atmosphere seemed to favour an increase of typhus, whereas dryness with cold had a contrary influence. Murchison was unable to trace any such connection, but points out that exposure to cold and wet, if long continued, depresses the nervous system, and so favours the onset of typhus.

#### 6. *Smallpox.*

Turning now to the principal eruptive fevers, we find that, although the incidence of smallpox is apparently *independent of climate*, yet the *season of the year* has a marked influence upon the prevalence of the disease. Nearly all writers are agreed that, while outbreaks of smallpox may occur at all seasons, they mostly begin towards the end of autumn and in the early spring, or in the cold season. In a word, smallpox is essentially a *disease of winter and spring*. In the British Islands and Western Europe generally, for example, the monthly number of cases is high from November onwards; but from May a rapid decline in the prevalence of the disease takes place, the least number of cases being observed in September.

The diagram (Fig. 96, p. 438) is copied from the Annual Summary of Births and Deaths of the Registrar-General for England for 1890. It shows the weekly departure from the average weekly number of deaths from smallpox (17) in London in the fifty years 1841-1890, inclusive.

In this diagram the thick horizontal line represents the mean

<sup>1</sup> "On Atmospheric Conditions influencing the Prevalence of Typhus," *Dublin Quarterly Journal of Medical Science*, May, 1866.

weekly mortality from smallpox in London, on the supposition that the mortality is spread equally over the fifty-two weeks of the year—the fifty-third week, when it occurs, being ignored. The curved line represents the amount per cent. by which the

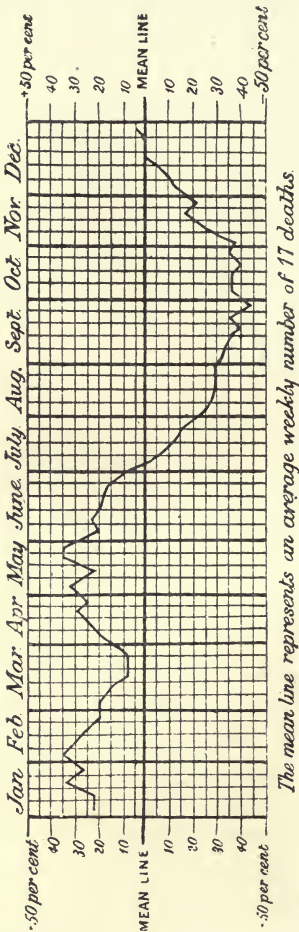

FIG. 96.—THE MORTALITY CURVE FOR SMALLPOX (50 YEARS, 1841-1890).

*The mean line represents an average weekly number of 17 deaths.*

average mortality in each week differs from this mean. When the percentage for any week is above the mean, the amount of the percentage excess is marked above the horizontal line representing the mean; and when the percentage is below the mean, it is marked below the line.

It must be remembered that the data on which the curve is formed are the deaths registered in each week, not the deaths which occurred in the week, and that the registration is usually a few days after the death; and, secondly, that the curve relates to deaths—that is, the final termination of the attack of illness, and not its commencement. So that, in estimating the effect of season in generating smallpox, allowance must be made for the average duration of this disease when fatal—that is, eleven or twelve days. It is, moreover, possible that the curve of mortality may, for another reason, not accurately represent the curve of prevalence. For it may

be that an attack of smallpox is more likely to terminate fatally if it occurs at one season—for example, midwinter—than if it occurs at another, such as midsummer.

The diagram shows that at the beginning of February and in

the second half of May the weekly number of deaths was 35 per cent. in excess of the average weekly number of seventeen deaths represented by the mean line, whereas at the end of September there was a deficit of 43 per cent. in the weekly number of deaths as compared with the same average weekly number over the whole year.

In Dublin, during the autumn of 1871, the prevalence of, and mortality from, smallpox increased with a fall of mean temperature below 50° F., and the greatest severity of the epidemic was experienced in the first half of the following April, shortly after a period of intense cold for the time of year. With the rise of mean temperature to between 55° and 60° F. in the middle of June, the epidemic declined rapidly. Abundant rainfalls seemed to be followed by remissions in the severity of the epidemic, and the converse was also true.<sup>1</sup>

Buchan and Mitchell say that the curve for smallpox is one of the simplest of the curves, showing that the mortality from the disease is above the average from Christmas till the end of June, the maximum falling in the last week of May, and the minimum in the last week of September.

From statistics as to the prevalence of the disease in Sweden, by months, in the years 1862-1869 inclusive,<sup>2</sup> it appears that the greatest prevalence of smallpox is observed in May, the cases in that month being 13·7 per cent. of the total cases occurring in the year; while the least prevalence is observed in September, when only 3·9 per cent. of all the cases in the year occur. From November the monthly number of cases is high, but from May a rapid decline in the prevalence of the disease takes place.

When due allowance has been made for difference of climate, these results agree very closely with the observations which have been recorded in this country on the relation of smallpox to season. Dr. Edward Ballard,<sup>3</sup> writing of the epidemic of 1871, observed :

<sup>1</sup> *Manual of Public Health for Ireland*, 1875, p. 298. Dublin: Fannin and Co. See also Buchan and Mitchell's Paper in the *Journal of the Scottish Meteorological Society*, 1874.

<sup>2</sup> These statistics were compiled from exhaustive annual reports by the late Dr. Wistrand, as to the morbidity of Sweden, and are the direct fruit of an admirable system of disease-registration, which has been in operation for many years in Sweden, and also in the other Scandinavian countries.

<sup>3</sup> *Medical Times and Gazette*, March 11, 1871.

“There is some reason for believing that the variations of the epidemic (of smallpox) from week to week are influenced to a certain extent by atmospheric conditions, and more especially by variation in temperature.”

He then quoted a series of remarkable coincidences between the fluctuations of mean temperature and those of the small-pox mortality in London during the winter of 1870-71. In the number of the *Medical Times and Gazette* for May 13, 1871, he wrote :

“The epidemic has now lasted a good six months. It may be regarded as assuming a distinctly epidemic form in November, shortly after the mean temperature of the air had fallen decidedly below 50° F. In the progress of the seasons we have now arrived at a time when this mean temperature is again reached. The mean temperature of the last three weeks, as recorded at Greenwich, has been 50°, 50·7°, and 49·7° F. It is customary about the second week in May for some check in the consecutive weekly rises of temperature to take place, but after this, in the ordinary or average progress of events, the steady rise towards the summer temperature may be expected to set in, and with it there is, at least, a hope that the epidemic will begin to fade.”

A week later the same writer said :

“The sudden fall of deaths in London from smallpox which occurred last week—namely, from 288 to 232—occurring about three weeks after the mean temperature of 50° F. was reached, appears to be confirmatory of the favourable hopes we expressed last week, that the epidemic had, for this season, arrived at its climax.”

And so it had, for, although the decline was occasionally interrupted, the virulence of the epidemic was broken in May, in accurate fulfilment of the anticipations which had been grounded on a consideration of the influence of temperature on its progress.

#### 7. Measles.

*Seasonal Prevalence.*—Although, like smallpox, apparently independent of climate—for it is met with alike amidst Arctic snows, in temperate latitudes, and under the tropical sun—measles prevails especially in the *spring* and *autumnal quarters*



of the year. An analysis of the weekly returns of deaths from measles in the Dublin Registration District, published by the Registrar-General for Ireland, long since led me to the conclusion that a mean temperature above  $58.6^{\circ}$  F. was not favourable to the spread of this disease, and that a mean temperature below  $42.0^{\circ}$  F. was equally inimical to its prevalence.<sup>1</sup> These results are in strict accord with those arrived at by Dr. Edward Ballard, who says<sup>2</sup> that the only condition concerned in the arrest of the spread of measles in summer is the rise of the temperature of the air above a mean of  $60^{\circ}$  F., while towards winter a fall below  $42^{\circ}$  F. also distinctly tends to check the disease.

The accompanying diagram (Fig. 97), copied from the Annual Summary of Births, Deaths, and Causes of Death in London and other great towns for 1890, by the Registrar-General for England, is based upon the weekly returns of deaths from measles in London for the fifty years 1841-1890, inclusive. In it the mean line represents an average weekly number of thirty-four deaths from the disease under discussion, and the weekly curve

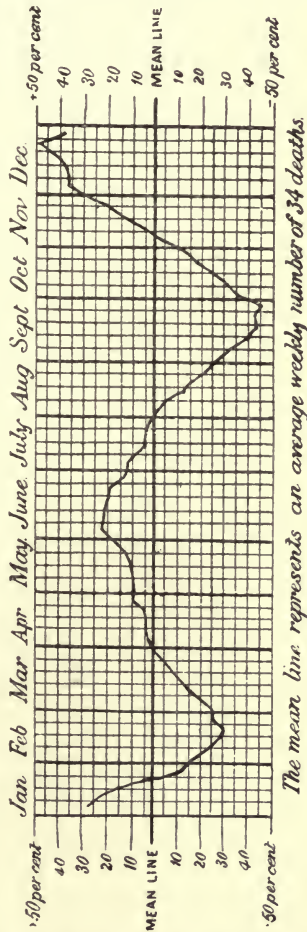

The mean line represents an average weekly number of 34 deaths.

FIG. 97.—THE MORTALITY CURVE FOR MEASLES (50 YEARS, 1841-1890).

shows a double maximum and a double minimum, the larger maximum falling in November, December, and January, with an extreme excess of 50 per cent. in the fourth week of December, and the

<sup>1</sup> *Manual of Public Health for Ireland*, pp. 300, 301. 1875.

<sup>2</sup> *Eleventh Report of the Medical Officer of the Privy Council*, No 3, pp. 54-62. 1868.

smaller in May and June, with an extreme excess of 25 per cent. in the first week of June. The larger minimum falls in August, September, and October, extreme deficit being 45 per cent. below the average in the last week of September, and the smaller minimum in February and March—extreme deficit, 30 per cent. below average in the third week of February.

According to Buchan and Mitchell, who examined the London death-rates for the thirty years beginning with 1845 and ending with 1874, the measles curve is remarkable in showing a double maximum and minimum during the year, the larger maximum occurring in November, December, and January, and the smaller in May and June; the larger minimum in August, September, and October, and the smaller in February and March. The most rapid fluctuation takes place in the fall observed from Christmas to the middle of February, the weekly deaths falling from 50 per cent. in excess of the average to 30 per cent. below it—that is, from fifty-one to twenty-four, the average weekly number of deaths throughout the year being thirty-four. This curve is one of the steadiest from year to year, both the December and the June maxima being well marked in nearly every one of the thirty years analysed by Buchan and Mitchell, and the yearly minima also being well marked.

In Table XV. is contained an analysis of the deaths from measles registered in the Dublin Registration District during the thirty years ending 1901, with the corresponding figures for scarlet fever. The two annual maxima and minima for measles are shown in the last column, but it will be observed that, as compared with London, the Dublin spring minimum is feebly marked, while the incidence of the autumnal minimum is later. Similarly, the summer maximum falls later in Dublin than it does in London.

It is instructive to compare the figures for measles with those for scarlet fever. It will be seen that these diseases are correlative, measles being very much in evidence when scarlet fever is infrequent, and the latter disease attaining its autumnal maximum when the prevalence of measles only is beginning to increase.

8. *Scarlatina or Scarlet Fever.*

*Climatic Influences* do not play a prominent part in determining the geographical distribution of this disease, for although the tropical and subtropical regions of Asia and Africa have so far almost entirely escaped scarlet fever, yet it has often prevailed epidemically in the tropical countries of South America; and, on the other hand, in certain cold or temperate climates scarlet fever is among the rarest of diseases.

There is, however, evidence that *season* does influence its prevalence. "*Scarlatina*," observes the Registrar-General of England,<sup>1</sup> "discovers a uniform, well-marked tendency to increase in the last six months, and attain its maximum in the December quarter, the earlier half of the following year witnessing a decrease." In Dublin, also, the disease is almost invariably most prevalent and fatal in the fourth quarter of the year (see Table XV., p. 444).

From an analysis of the weekly death-rate from scarlatina in Dublin, it would seem that this fever shows a tendency to increase when the mean temperature

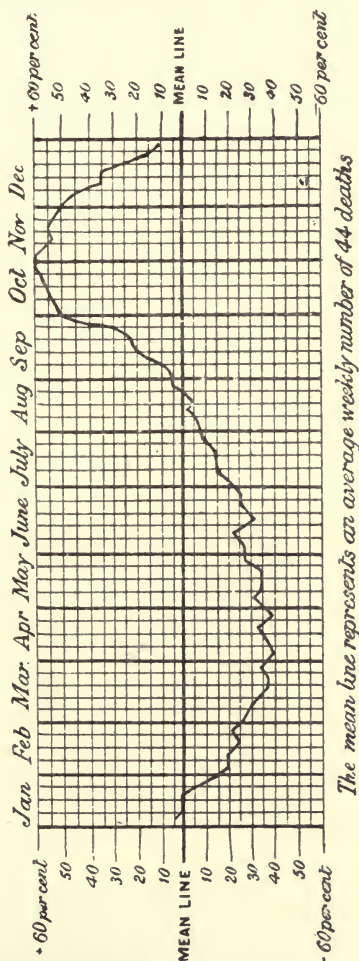

FIG. 98.—THE MORTALITY CURVE FOR SCARLET FEVER (30 YEARS, 1861-1890).

<sup>1</sup> *Twenty-eighth Annual Report of Births, Deaths, and Marriages*, p. 38.

TABLE XV.—SHOWING THE TOTAL NUMBER OF DEATHS FROM SCARLET FEVER AND FROM MEASLES IN THE DUBLIN REGISTRATION DISTRICT IN EACH OF THIRTEEN FOUR-WEEK PERIODS IN THE THIRTY YEARS 1872-1901; THE AVERAGE YEARLY NUMBER OF DEATHS FROM THESE DISEASES IN THE DECENNIAL PERIODS 1872-1881, 1882-1891, and 1892-1901 RESPECTIVELY; AND THE PERCENTAGE OF THE TOTAL MORTALITY FROM THE SAME FEVERS IN EACH OF THE SAID PERIODS.

Four-Week Periods.	Average Number of Deaths, 1872-1881.		Average Number of Deaths, 1882-1891.		Average Number of Deaths, 1892-1901.		Total Number of Deaths in 30 Years.		Percentage of the Average Annual Deaths from—	
	Scarlet Fever.	Measles.	Scarlet Fever.	Measles.	Scarlet Fever.	Measles.	Scarlet Fever.	Measles.	Scarlet Fever.	Measles.
I. Jan. 1 to Jan. 28	25.2	17.1	14.2	20.6	5.0	10.7	44.4	48.4	8.7	8.7
II. Jan. 29, Feb. 25	21.3	13.8	9.7	19.8	5.4	15.2	36.4	48.8	7.2	8.8
III. Feb. 26, Mar. 25	23.3	9.8	7.7	22.3	5.0	24.2	36.0	56.3	7.1	10.2
IV. Mar. 26, Ap. 22	20.9	12.7	5.9	19.5	4.5	19.8	31.3	52.0	6.2	9.4
V. Ap. 23, May 20	20.0	13.4	8.6	17.3	3.7	16.9	32.3	48.6	6.4	8.8
VI. May 21, June 17	20.7	14.7	7.2	13.6	3.3	13.1	31.2	41.4	6.1	7.5
VII. June 18, July 15	20.3	16.9	6.7	16.7	3.7	10.0	30.7	43.6	6.0	7.9
VIII. July 16, Aug. 12	19.5	14.6	6.7	13.9	3.7	8.4	29.9	36.9	5.9	6.7
IX. Aug. 13, Sept. 9	21.0	10.9	8.7	10.1	4.8	7.8	34.5	28.8	6.8	5.2
X. Sept. 10, Oct. 7	25.2	10.0	11.8	5.6	4.4	11.5	41.4	27.1	8.1	4.9
XI. Oct. 8, Nov. 4	29.7	13.9	18.0	4.1	5.5	19.1	53.2	37.1	10.5	6.7
XII. Nov. 5, Dec. 2	31.6	16.1	19.6	6.1	6.5	17.4	57.7	39.6	11.4	7.2
XIII. Dec. 3, Dec. 30	25.2 <sup>1</sup>	26.9 <sup>2</sup>	17.6 <sup>1</sup>	5.7 <sup>2</sup>	6.5 <sup>1</sup>	11.6 <sup>2</sup>	49.3	44.2	9.7	8.0
Totals ..	3,039	1,908	1,424	1,753	620	1,857	5,083	5,528	100.0	100.0

<sup>1</sup> Including 9 deaths registered in the fifty-third week of 1873, and 4 deaths in that of 1879, 11 in that of 1884, 2 in that of 1890, and 1 in that of 1896.

<sup>2</sup> Including 3 deaths registered in the fifty-third week of 1879, 3 in that of 1884, 6 in that of 1890, and 5 in that of 1896.



rises much above 50° F., while a fall of mean temperature below this point in autumn checks the further rise of the mortality.<sup>1</sup> In this city scarlet fever is most fatal in the forty-sixth week of the year (middle of November) and least fatal in the twenty-fourth week (middle of June). Dr. Edward Ballard long ago drew inferences which confirm these results.<sup>2</sup> The Annual Summary of Births, Deaths, and Causes of Deaths, of the Registrar-General of England, for 1890, is illustrated by the diagram on p. 443, showing the weekly mortality curve for scarlet fever in London on an average of thirty years (1861-1890). The curve consists of a single wave, which rises to its crest (60 per cent. above the mean line, which represents an average weekly number of forty-four deaths) in October and November, while the trough extends from February to August. It is a suggestive fact that the corresponding curves for diphtheria and enteric fever are also single-wave curves, closely resembling each other and the curve of scarlatina, in rising to a crest in October and November, and showing a trough from February to August.

From their analysis of the deaths from scarlet fever registered in London in the thirty years 1845-1874, Buchan and Mitchell concluded that this disease has its maximum from the beginning of September to the end of the year, and its minimum from February to July. The period of the highest death-rate is from the beginning of October to the end of November, being nearly 60 per cent. above the average; and the lowest in March, April, and May, when it is about 33 per cent. below its average. In each of the thirty years the deaths increased at the time of mean maximum, and in all except four of the years the increase was considerable. During ten of the years a high death-rate was continued on into the year immediately following, but in every year the deaths became fewer, and diminished steadily, if not rapidly.

<sup>1</sup> *Manual of Public Health for Ireland*, pp. 303, 304. 1875.

<sup>2</sup> *Eleventh Report of the Medical Officer of the Privy Council*, No. 3, pp. 54-62. 1868.

## CHAPTER XXIX

### THE SEASONAL PREVALENCE OF PNEUMONIC OR LUNG FEVER<sup>1</sup>

IN April, 1875, the late Dr. T. W. Grimshaw, C.B., afterwards Registrar-General for Ireland, and I, read before the Medical Society of the King and Queen's College of Physicians a paper on what we ventured to call "Pythogenic Pneumonia." This paper, which was published in the number of the *Dublin Journal of Medical Science* for May, 1875,<sup>2</sup> was based upon observations of pneumonia in Steevens' and Cork Street Hospitals, Dublin, during the summer of 1874—when an epidemic of the disease prevailed in the Irish capital—as well as upon an analysis of the statistics of death from bronchitis and pneumonia registered in Dublin during nine years ending with 1873. In the same communication the meteorological and epidemic conditions of 1874 were discussed, and our researches seemed to warrant us in drawing the following conclusions :

1. That the bibliography of pneumonia indicates the existence of a form of the disease which arises under miasmatic influences, and is contagious.

2. That this view is supported by the relation which exists between this form of pneumonia and certain zymotic affections—notably enteric fever and cholera—and by the resemblance between it and epizoötic pleuro-pneumonia.

3. That its ætiology justifies us in regarding the disease as a zymotic affection, and in naming it "*pythogenic pneumonia*."

4. That pythogenic pneumonia presents peculiar clinical

<sup>1</sup> Reprinted, by permission, from the *Transactions of the Ninth Session of the International Medical Congress*, vol. v., p. 45. Washington, D.C., U.S.A. 1887.

<sup>2</sup> Vol. lix., No. 41, p. 399. Third Series.

features which enable us to distinguish it from ordinary pneumonia.

5. That much of the pneumonia which prevailed in Dublin during 1874 was of this pythogenic character.

6. That whereas ordinary pneumonia is specially prevalent during a continuance of cold, dry weather, with high winds and extreme variations in temperature, pythogenic pneumonia reaches its maximum during tolerably *warm* weather, accompanied with a dry air, deficient rainfall, hot sun, and rapid evaporation.

The years which have elapsed since the publication of this paper on "Pythogenic Pneumonia" have been fruitful in the literature of the subject to an unprecedented degree. Among the many monographs on pneumonia which have of late appeared, perhaps the most valuable are that by the late Dr. August Hirsch, Professor of Medicine in the University of Berlin, on the Geographical and Historical Pathology of the Disease,<sup>1</sup> and that by the late Dr. C. Friedländer, of Berlin, on the "Micrococci of Pneumonia."<sup>2</sup>

Hirsch, after pointing out that pneumonia, even in its narrowest acceptance of fibrinous or so-called croupous pneumonia, is an anatomical term that includes several inflammatory processes differing from one another in their ætiology, goes on to observe that the prevalence of the malady depends very decidedly upon certain influences of season and weather. He gives an elaborate table of percentages of pneumonic prevalence in the several months at a large number of places in Europe and America. According to this table, the largest number of cases falls in the months from February to May, the smallest number in the period from July to September. Taking the average for all the places mentioned in the table, it appears that 34·7 per cent. of the patients were attacked in spring (March to May inclusive); 29·0 per cent. in winter (December to February); 18·3 per cent. in autumn (September to November); and 18·0 per cent. in summer

<sup>1</sup> *Handbook of Geographical and Historical Pathology*, vol. iii. Translated from the second German edition, by Charles Creighton, M.D. London: The New Sydenham Society. 1886.

<sup>2</sup> *Fortschritte der Medicin*. Band 1, Heft 22. November 22, 1883. Translated for the New Sydenham Society by Edgar Thurston. 1886.

(June to August). The combined percentage for winter and spring is 63·7; that for summer and autumn is 36·3. If the number of cases in summer be taken as 1, then autumn has 1·02, winter 1·6, and spring 1·9. Nearly all the recorded epidemics of pneumonia have occurred in winter and spring. From the foregoing considerations, Hirsch confidently concludes that the origin of the malady is dependent on weather influences proper to winter and spring, and more particularly on *sudden changes of temperature and considerable fluctuations in the proportion of moisture in the air*. He holds that any exceptionally large number of cases of "inflammation of the lungs" at the other seasons, more especially in summer, has coincided with the prevalence of the same meteorological conditions phenomenally at that season.

"But that conclusion," he goes on to say, "is still further borne out by the fact that in those northern regions (Russia, Sweden, Denmark, Germany, England, the North of France, and the Northern States of the American Union) where the most sudden and severe changes of temperature fall in spring, the largest number of cases is met with in spring also; while in the warmer and sub-tropical countries (Italy, islands of the Mediterranean, Spain and Portugal, Greece, Algiers, Southern States of the Union, Chili, and Peru), which are subject to those meteorological influences, for the most part, in winter, it is winter that represents the proper season of pneumonia. And that applies not merely to sporadic cases, but, in part at least, to epidemic outbreaks of the malady as well. One other fact deserves to be noticed here—namely, that those tracts of country, especially in the tropics, which are highly favoured in their climate or in the steadiness of the temperature from day to day (Egypt, many parts of India, including Bengal and the plain of Burmah, California, etc.), are subject to pneumonia to a comparatively slight extent."

In the paper on "Pythogenic Pneumonia," by Dr. Grimshaw and myself, will be found a table, compiled from the returns of the Registrar-General for Ireland, which shows the number of deaths from bronchitis and pneumonia registered in the Dublin Registration District in each quarter of the nine years 1865-1873,



inclusive. According to that table, of every 100 deaths from bronchitis, 44 on the average occurred in the first quarter of the year, 22 in the second, only 10 in the third, and 24 in the fourth quarter. Thus, the mortality from bronchitis was twice as great in the first as it was in the second quarter, and more than four times greater in the first than in the third quarter.

Very different were the facts as to pneumonia : of every 100 deaths from this disease, 32 on the average occurred in the first quarter, 27 in the second, 16 in the third, and 25 in the fourth quarter. The mortality from pneumonia was only *one-fifth* greater in the first than in the second quarter, and only twice as great in the first as in the third quarter. The extreme winter fatality of bronchitis and its low summer fatality were equally wanting in the case of pneumonia.

A careful analysis of the weekly returns of the Registrars-General of England and Ireland for ten years ending with 1885, and of the same returns for the year 1886, brings out a similar remarkable contrast between bronchitis and pneumonia, as to the time of year when these diseases are respectively most prevalent and fatal in London and Dublin.

Table XVI. contains the figures relating to pneumonia, and Table XVII. those relating to bronchitis. Each table sets forth the weekly average number of deaths in London and in Dublin from pneumonia and bronchitis respectively, in the ten years 1876-1885, as well as the actual weekly number of deaths from these diseases in the year 1886.

In Tables XVIII. and XIX. these numerical results are thrown into curves.

It will be observed that the statistics for London and for Dublin agree to a remarkable extent. In both cities bronchitis falls to a very low ebb in the third, or summer, quarter of the year (July to September inclusive), when only 12 per cent. of the deaths annually caused by this disease take place in Dublin, and only 11 per cent. in London. In the last, or fourth, quarter (October to December inclusive), the percentage of deaths from bronchitis rises to 27 in Dublin and to 30 in London. The maximal mortality occurs in the first quarter (January to March inclusive), when it is 38 per cent. in both London and Dublin.

TABLE XVI.—SHOWING THE DEATHS FROM PNEUMONIA, BY WEEKS AND QUARTERS, IN DUBLIN AND LONDON, IN THE TEN YEARS 1876-1885 INCLUSIVE, AND IN THE YEAR 1886.

Week.	DUBLIN REGISTRATION DISTRICT.				LONDON REGISTRATION DISTRICT.											
	First Quarter.		Second Quarter.		Third Quarter.		Fourth Quarter.									
	1876-1885.	1886.	1876-1885.	1886.	1876-1885.	1886.	1876-1885.	1886.								
1	8.6	7	9.5	7	5.1	10	3.5	5	107.0	117	127.3	84	63.7	64	73.1	56
2	9.0	10	8.9	8	4.9	1	4.5	2	106.4	113	124.7	95	62.0	56	75.8	75
3	6.7	4	8.9	11	3.0	0	5.7	5	111.1	109	111.8	100	56.2	56	86.3	83
4	9.8	7	9.5	4	3.9	1	5.6	6	110.1	90	109.1	73	58.3	53	101.6	59
5	9.1	9	9.5	9	3.7	4	5.2	5	125.6	114	101.6	93	60.2	42	103.4	80
6	7.0	7	9.6	9	4.8	7	6.9	1	123.5	122	97.4	95	57.9	46	114.8	90
7	10.5	11	7.2	5	2.9	2	6.7	4	121.5	128	90.0	107	51.9	51	112.3	91
8	7.7	7	8.5	10	4.5	1	7.8	5	104.9	139	87.6	80	53.9	45	120.8	95
9	9.5	5	8.2	5	4.3	1	7.9	5	93.7	146	83.9	58	49.4	48	116.4	121
10	10.2	9	8.8	6	3.7	2	7.9	9	104.5	206	76.3	83	50.9	34	106.6	110
11	7.8	17	8.0	6	3.2	1	7.8	7	109.8	182	74.6	60	51.3	54	111.8	101
12	7.9	11	5.4	9	4.1	1	6.6	2	120.1	165	66.2	72	58.1	48	115.4	112
13	8.4	11	6.8	4	3.3	1	9.8	9	129.0	125	72.0	64	61.0	43	111.9	127
Totals ..	112.2	115	108.8	93	51.4	32	85.9	65	1467.2	1756	1222.5	1064	734.8	640	1350.2	1200
Per cent. ..	31.3	37.7	30.4	30.5	14.4	10.5	23.9	21.3	30.7	37.7	25.6	22.8	15.4	13.7	28.3	25.8

Total deaths from pneumonia :  
London, 1876-1885 (average), 4774.7; 1886, 4,660.

Total deaths from pneumonia :  
Dublin, 1876-1885 (average), 358.3; 1886, 305.

TABLE XVII.—SHOWING THE DEATHS FROM BRONCHITIS, BY WEEKS AND QUARTERS, IN DUBLIN AND LONDON, IN THE TEN YEARS 1876-1885 INCLUSIVE, AND IN THE YEAR 1886.

Week.	DUBLIN REGISTRATION DISTRICT.				LONDON REGISTRATION DISTRICT.											
	First Quarter.		Second Quarter.		Third Quarter.		Fourth Quarter.									
	1876-1885.	1886.	1876-1885.	1886.	1876-1885.	1886.	1876-1885.	1886.								
1	43·4	26	38·0	30	11	18·9	7	314·7	338	218	106·8	93	135·9	124		
2	42·3	21	31·6	20	15·9	8	19·8	311·8	351	277·5	213	102·8	88	166·1		
3	44·5	32	36·0	27	12·6	13	18·9	350·2	308	239·8	179	97·2	71	195·9		
4	49·7	29	29·0	30	13·2	10	22·6	368·2	330	222·7	175	92·8	84	221·6		
5	48·3	38	26·4	22	12·4	4	24·3	435·6	304	193·0	179	95·7	82	237·5		
6	54·3	40	26·9	16	11·7	16	26·5	405·2	394	189·8	166	90·5	76	266·1		
7	50·2	52	21·5	13	13·0	7	29·7	340·7	452	172·1	137	91·6	74	272·1		
8	43·4	47	24·2	17	11·2	10	34·1	290·9	439	157·3	108	83·7	89	289·5		
9	38·6	28	23·2	24	13·0	13	32·8	289·9	526	146·0	91	86·6	63	297·5		
10	37·3	55	22·8	11	12·5	9	39·4	295·2	566	143·2	96	82·5	59	294·4		
11	35·0	41	20·2	11	14·5	17	42·1	304·4	646	124·4	90	95·5	85	345·3		
12	41·4	38	19·0	15	14·1	14	43·3	318·9	474	114·2	82	109·7	71	342·2		
13	38·5	28	19·4	8	15·6	6	43·0	332·8	330	108·1	98	118·4	102	347·1		
Totals	566·9	475	338·2	244	172·7	138	395·4	4358·5	5458	2397·1	1832	1253·8	1037	3413·2	2957	
Per cent.	38·5	42·1	23·0	21·7	11·7	12·2	26·8	38·2	48·4	21·0	16·2	11·0	9·2	29·8	26·2	
	Total deaths from bronchitis : Dublin, 1876-1885 (average), 1473·2; 1886, 1127.				Total deaths from bronchitis : London, 1876-1885 (average), 11422·6; 1886, 11284.											

In the second, or spring, quarter (April to June inclusive), the deaths from bronchitis declined to 23 per cent. in Dublin, and to 21 per cent in London.

The mortality from "pneumonic fever" is very differently distributed throughout the year. In the summer quarter more than 14 per cent. of the deaths yearly referable to this disease

Table XVIII. Showing the average weekly number of Deaths from Bronchitis, and from Pneumonia, in the Decade 1876-1885 in the Dublin Registration District.

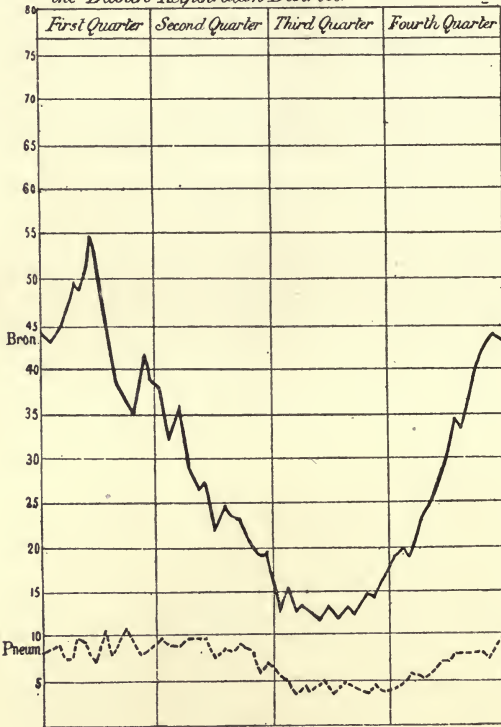

are recorded in Dublin, and more than 15 per cent. in London. In the first quarter the figures are : Dublin, 31 per cent. ; London, 31 per cent. ; in the second quarter they are : Dublin, 30 per cent. ; London, 26 per cent. ; in the fourth quarter they are : Dublin, 24 per cent. ; London, 28 per cent.

From these numerical results it therefore appears that the



fatality and (indirectly) the prevalence of pneumonic fever from season to season do not correspond with the seasonal prevalence and fatality of bronchitis. The latter disease—be it of primary or secondary origin—increases and kills in direct relation to the setting in of cold weather, with excessive relative humidity and increased and frequent precipitation in the form of rain, snow

Table XII. *Showing the average weekly number of Deaths from Bronchitis, and from Pneumonia in the Decade 1876-1885 in London.*

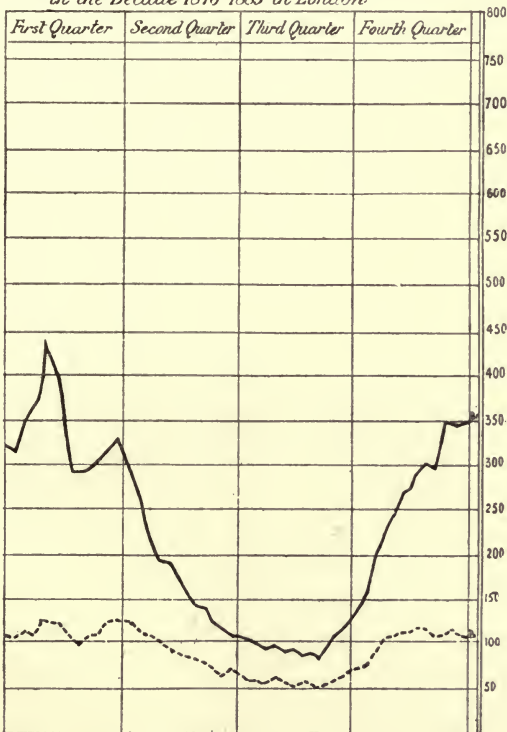

or sleet, and hail. It subsides in prevalence and fatality with the advance of spring and the advent of summer.

Pneumonic fever, on the other hand, increases less quickly in winter, and remains more prevalent and fatal in spring and summer, than bronchitis; its maximal incidence coincides with the season of dry, harsh winds and hot sunshine in spring, when

also the relative humidity is low, precipitation is scanty, while the diurnal range of temperature is extreme.

A closer study of Tables XVIII. and XIX. yields some interesting results. In the first place, we observe that the London curves of deaths both from bronchitis and pneumonia vary less from week to week than the corresponding curves for Dublin, which are much less regular, and, as it were, more serrated. The reason for this evidently is, that in the case of London we have to deal with a population which is about twelve times greater than that of Dublin, hence the law of periodicity fulfils itself with greater exactness in the vast population of London than in the comparatively small population of Dublin. The death curves of the larger city are, as it were, seen through a magnifying glass of ten diameters, in the corresponding death curves of Dublin, the variations from week to week being magnified or multiplied tenfold. In the second place, it will be noticed that bronchitis is uniformly throughout the year less fatal in proportion to the population in London than it is in Dublin, while the converse is true of pneumonia. According to the Census of 1881, the middle year of the decade with which we are at present concerned, the population of the London Registration District was 3,893,272; that of the Dublin Registration District was 348,293. The average quarterly number of deaths from bronchitis in the ten years, 1876-1885, were these :

First quarter, Dublin, 566·9; London, 4358·5.

Second quarter, Dublin, 338·2; London, 2397·1.

Third quarter, Dublin, 172·7; London, 1253·8.

Fourth quarter, Dublin, 395·4; London, 3413·2.

On the other hand, the average quarterly number of deaths from pneumonia in the same ten years were :

First quarter, Dublin, 112·2; London, 1467·2.

Second quarter, Dublin, 108·8; London, 1222·5.

Third quarter, Dublin, 51·4; London, 734·8.

Fourth quarter, Dublin, 85·9; London, 1350·2.

The third point of interest in Tables XVIII. and XIX. is the dip in the death curve from bronchitis, both in London and in

Dublin, from the seventh to the tenth week of the year. This would seem to depend on several causes—firstly, the removal by death at the beginning of the year of those individuals who were most susceptible to bronchitis; secondly, the acclimatisation of the surviving population to the continued cold of winter; and thirdly, the prevalence of south-west winds and open weather toward the close of January and early in February. With the setting in of the searching east winds of early spring the death curve again rises at the beginning of March, when also there is a marked rise in the death-toll exacted by pneumonia, more especially in London.

Another curious point is, that the changes in the contour of the death curves apparently occur a week earlier in London than they do in Dublin. Delay in registration in the latter city seems to be the explanation of this otherwise puzzling circumstance.

It will be observed that in the foregoing analysis only statistics of deaths are considered, and these, unfortunately, are of minor value compared with statistics of the prevalence of bronchitis and of pneumonia respectively, were such available. Let us hope that the day is not far distant when registration of disease will be compulsory, as registration of the cause of death is at present. Until this much-needed reform is carried into effect, statistical inquiries into the prevalence of disease in localities and in seasons will want much of that precision which alone can give them scientific value.

How are we to explain the continued frequency of pneumonic fever in summer and autumn? In my opinion the solution of this paradox is to be sought in the consideration of the *pythogenic* origin of the disease in many instances, and particularly in the warm season of the year. In a word, I would regard exposure to cold, extremes of temperature, harsh, drying winds, and other personal or climatological conditions as merely so many *pre-disposing* causes of the disease, while I would reserve for the introduction into the system of a specific virus or contagium the rôle of an *exciting* cause—perhaps the sole exciting cause—of pneumonic fever. As to the exact nature of that virus or contagium, we are now comparatively well-informed, thanks to the

researches and discoveries of Klebs, Eberth, Koch, Fränkel, and Friedländer. Chief among the bacteria of pneumonia are the *Diplococcus lanceolatus capsulatus pneumoniæ* of Fränkel and the *Bacillus pneumoniæ* (*Pneumoniëkokken*) of Friedländer. Modern researches in bacteriology are full of promise. We stand on the threshold of a new Science of Medicine, and before long a still greater flood of light will doubtless be shed upon the intimate nature and pathology of pneumonia as well as of other blood diseases.

In the *Medical Report of Cork Street Fever Hospital and House of Recovery, Dublin*, for the year 1884, I ventured to assert that the claims of pneumonia to be considered a specific fever rested principally upon—

1. Its not infrequent epidemic prevalence, which the bibliography of the disease places beyond dispute.

2. Its proved infectiousness in some instances, as, for example, those observed at Dalton in the spring months of 1883, by Dr. E. Slade King, and Mr. Sloane Michell, M.R.C.S., England.<sup>1</sup>

3. Its occasional pythogenic origin, and the remarkable correlation which appears to exist between it and enteric fever.

4. Its mode of onset, or "invasion," which exactly resembles that of the recognised specific fevers.

5. The appearance of constitutional symptoms before the development of local signs, or even local symptoms in many instances; in other words, the existence of a "true period of invasion."

6. The critical termination of the febrile movement in all uncomplicated cases.

7. The presence of local epi-phenomena in connection with the skin, such, for example, as eruptions of herpes, sweat rashes, and the occurrence of desquamation.

8. The development of sequelæ in some cases, such as an attack of nephritis, followed by renal dropsy, ataxia like that observed after typhus or diphtheria, mania, and so on.

9. The discovery of a bacterium in pneumonic exudation, to which analogy, at all events, points as pathognomonic.

In my hospital and private practice I have acquired the

<sup>1</sup> Cf. *The Practitioner*. April, 1884.



habit of expressing the relation of the local lesion in pneumonia, or pneumonic fever (lung fever), to the essential disorder, in terms of the intestinal lesions in enteric fever to that disease. Just as physicians and pathologists have long since come to avoid the dangerous error—I would even say heresy—of Broussais and his school, who held that the pyrexia or feverishness in enteric fever was symptomatic of and secondary to a local inflammation of the glands of the small intestine, so we shall come in time to avoid the similar and not less dangerous, but more widely disseminated, error of regarding the pyrexia in pneumonia as symptomatic of and secondary to a local inflammation of the lungs. The day is seemingly not far distant when we shall speak of “pneumonic fever” in precisely the same way as we use the term “enteric fever” at present—that is, to signify a disease due to a zymotic or specific blood infection, manifesting itself after the lapse of a certain time, by physical phenomena—objective and subjective—connected, in this instance—generally, but by no means of necessity—with the lungs.



## APPENDIX

### GREEN FLASH

*The Green Flash on the Horizon at Sunset.*—In *Nature* (vol. xxix., p. 7) the Rev. G. H. Hopkins, of Week, St. Mary Rectory, Bude, Cornwall, writes: "In a clear sky, as the disc of the sun sinks down below the horizontal line of the ocean, the parting ray is a brilliant emerald green. . . . The same effect is not produced by the sun setting behind a distant bank of clouds. Probably the first ray from the rising sun would be the same unexpected colour." On p. 76 of the same volume of *Nature* Mr. William Swan describes a similar appearance which was seen by him at sunrise from the summit of the Rigi on September 13, 1865. He writes: "The very first rays, although necessarily proceeding from the comparatively obscure limb of the sun, were dazzlingly brilliant, and of a superb emerald green colour." Many references to the "green flash" will be found scattered through the pages of the *Journal of the British Astronomical Association*, and the phenomenon attracted great interest among the readers of *Symons's Meteorological Magazine* some years ago, so that in vol. xli. of that publication we find several interesting communications on the subject.

Notable among these is an article by Professor Arthur A. Rambaut, D.Sc., F.R.S., Radcliffe Observer in the University of Oxford, who saw the green flash for the first time on the evening of September 27, 1905. He was then returning from the meeting of the British Association in South Africa, on board the s.s. *Durham Castle*, and, as the sun set behind the grand range of hills terminating in Cape Guardafui, East Africa, he was fortunate enough to see the phenomenon to perfection. As to its cause, the

view had been put forward by Mr. R. C. Cann Lippincott and others that the green flash seen as the last ray of the setting sun disappears is the apparent image or spectrum of the sun which has just sunk below the horizon seen in the complementary green colour.<sup>1</sup> But this physiological theory is disposed of by Professor Rambaut, who states<sup>2</sup> that the large number of observations of the "green flash" at *sunrise* affords a complete refutation of that hypothesis. According to him, the obvious and satisfactory explanation is that the "green flash" is due to the unequal refraction experienced by rays of different colours in passing through the Earth's atmosphere. It is a well-known fact that the setting sun has actually sunk completely beneath the horizon at the moment when it appears to us to be first in contact with it, and when the upper limb is just about to disappear it is actually 36 minutes of arc below the horizon. We see it in virtue of the refraction which bends the rays round the horizon so as to reach our eyes. The red, being the least refrangible, is the first to be lost, and the different colours of the spectrum vanish one by one in the order—red, orange, yellow, green, blue, indigo, and violet. Professor Rambaut remarks that the term "green flash" is unsatisfactory. When best seen, the colour of the remaining segment of the sun at setting turns, at the very last moment, from green to blue. The flash does not appear indigo or violet, partly owing to the relative feebleness with which these rays impress the eye, compared with the yellow, green, and blue rays; and partly because the selective absorption of the atmosphere cuts down the rays of shorter wave-length in a larger proportion than those which are less refrangible. The violet and indigo are thus most reduced.

<sup>1</sup> *Symons's Meteorological Magazine*, 1906, vol. xli., p. 11.

<sup>2</sup> *Ibid.*, p. 22.



## APPENDIX II

TABLE OF CORRECTIONS FOR REDUCING BAROMETRIC READINGS TO STANDARD GRAVITY, LATITUDE 45°

Lat. N. or S.	Correction.		Lat. N. or S.	Correction.		Lat. N. or S.	Correction.		Lat. N. or S.	Correction.	
	At 27".	At 30".		At 27".	At 30".		At 27".	At 30".		At 27".	At 30".
0	—	—	23	—	—	46	+	+	69	+	+
1	·070	·078	24	·049	·054	47	·002	·003	70	·052	·058
2	·070	·078	25	·047	·052	48	·005	·005	71	·054	·060
3	·070	·078	26	·045	·050	49	·007	·008	72	·055	·061
4	·070	·077	27	·043	·048	50	·010	·011	73	·057	·063
5	·069	·077	28	·041	·046	51	·012	·013	74	·058	·064
6	·069	·077	29	·039	·043	52	·015	·016	75	·059	·066
7	·068	·076	30	·037	·041	53	·017	·019	76	·061	·067
8	·068	·075	31	·035	·039	54	·019	·021	77	·062	·069
9	·067	·075	32	·033	·036	55	·022	·024	78	·063	·070
10	·067	·074	33	·031	·034	56	·024	·027	79	·064	·071
11	·066	·073	34	·028	·032	57	·026	·029	80	·065	·072
12	·065	·072	35	·026	·029	58	·028	·032	81	·066	·073
13	·064	·071	36	·024	·027	59	·031	·034	82	·067	·074
14	·063	·070	37	·022	·024	60	·033	·036	83	·067	·075
15	·062	·069	38	·019	·021	61	·035	·039	84	·068	·075
16	·061	·067	39	·017	·019	62	·037	·041	85	·068	·076
17	·059	·066	40	·015	·016	63	·039	·043	86	·069	·077
18	·058	·064	41	·012	·013	64	·041	·046	87	·069	·077
19	·057	·063	42	·010	·011	65	·043	·048	88	·070	·077
20	·055	·061	43	·007	·008	66	·045	·050	89	·070	·078
21	·054	·060	44	·005	·005	67	·047	·052	90	·070	·078
22	·052	·058	45	·002	·003	68	·049	·054		·070	·078
	·050	·056		± 0	± 0		·050	·056			

## APPENDIX III

## HYGROMETRICAL TABLES (Glaisher)

## I. TABLE OF FACTORS.

Reading of the Dry-Bulb Thermometer.	Factor.	Reading of the Dry Bulb Thermometer.	Factor.	Reading of the Dry-Bulb Thermometer.	Factor.
°		°		°	
20	8.14	44	2.18	68	1.79
21	7.88	45	2.16	69	1.78
22	7.60	46	2.14	70	1.77
23	7.28	47	2.12	71	1.76
24	6.92	48	2.10	72	1.75
25	6.53	49	2.08	73	1.74
26	6.08	50	2.06	74	1.73
27	5.61	51	2.04	75	1.72
28	5.12	52	2.02	76	1.71
29	4.63	53	2.00	77	1.70
30	4.15	54	1.98	78	1.69
31	3.70	55	1.96	79	1.69
32	3.32	56	1.94	80	1.68
33	3.01	57	1.92	81	1.68
34	2.77	58	1.90	82	1.67
35	2.60	59	1.89	83	1.67
36	2.50	60	1.88	84	1.66
37	2.42	61	1.87	85	1.65
38	2.36	62	1.86	86	1.65
39	2.32	63	1.85	87	1.64
40	2.29	64	1.83	88	1.64
41	2.26	65	1.82	89	1.63
42	2.23	66	1.81	90	1.63
43	2.20	67	1.80	91	1.62

HYGROMETRICAL TABLES—*continued*TABLE II.—TENSION, OR ELASTIC FORCE OF AQUEOUS VAPOUR  
IN INCHES OF MERCURY FOR EVERY DEGREE OF  
TEMPERATURE FROM 0° TO 95°.

Temp.	Ten-ion.	Temp.	Tension.	Temp.	Tension.	Temp.	Tension.
0		0		0		0	
0	·044	24	·129	48	·335	72	·785
1	·046	25	·135	49	·348	73	·812
2	·048	26	·141	50	·361	74	·840
3	·050	27	·147	51	·374	75	·868
4	·052	28	·153	52	·388	76	·897
5	·054	29	·160	53	·403	77	·927
6	·057	30	·167	54	·418	78	·958
7	·060	31	·174	55	·433	79	·990
8	·062	32	·181	56	·449	80	1·023
9	·065	33	·188	57	·465	81	1·057
10	·068	34	·196	58	·482	82	1·092
11	·071	35	·204	59	·500	83	1·128
12	·074	36	·212	60	·518	84	1·165
13	·078	37	·220	61	·537	85	1·203
14	·082	38	·229	62	·556	86	1·242
15	·086	39	·238	63	·576	87	1·282
16	·090	40	·247	64	·596	88	1·323
17	·094	41	·257	65	·617	89	1·366
18	·098	42	·267	66	·639	90	1·410
19	·103	43	·277	67	·661	91	1·455
20	·108	44	·288	68	·684	92	1·501
21	·113	45	·299	69	·708	93	1·548
22	·118	46	·311	70	·733	94	1·596
23	·123	47	·323	71	·759	95	1·646

APPENDIX IV

CONVERSION TABLES FOR EXPRESSING THE RESULTS OF OBSERVATIONS IN THE UPPER AIR IN ABSOLUTE UNITS<sup>1</sup>

A. ALTITUDE SCALES.

CONVERSION OF ENGLISH FEET TO METRES.<sup>2</sup>

English Feet.	0.	1.	2.	3.	4.	5.	6.	7.	8.	9.
	Metres.									
0	0	0.3	0.6	0.9	1.2	1.5	1.8	2.1	2.4	2.7
10	3.1	3.4	3.7	4.0	4.3	4.6	4.9	5.2	5.5	5.8
20	6.1	6.4	6.7	7.0	7.3	7.6	7.9	8.2	8.5	8.8
30	9.1	9.5	9.8	10.1	10.4	10.7	11.0	11.3	11.6	11.9
40	12.2	12.5	12.8	13.1	13.4	13.7	14.0	14.3	14.6	14.9
50	15.2	15.5	15.9	16.2	16.5	16.8	17.1	17.4	17.7	18.0
60	18.3	18.6	18.9	19.2	19.5	19.8	20.1	20.4	20.7	21.0
70	21.3	21.6	21.9	22.3	22.6	22.9	23.2	23.5	23.8	24.1
80	24.4	24.7	25.0	25.3	25.6	25.9	26.2	26.5	26.8	27.1
90	27.4	27.7	28.0	28.4	28.7	29.0	29.3	29.6	29.9	30.2
100	30.5	30.8	31.1	31.4	31.7	32.0	32.3	32.6	32.9	33.2

CONVERSION OF KILOMETRES INTO ENGLISH FEET UP TO 25 KILOMETRES.

Kilometres.	1,000 Feet.	Kilometres.	1,000 Feet.	Kilometres.	1,000 Feet.	Kilometres.	1,000 Feet.
0.5	1.6	5.5	18.0	10.5	34.4	15.5	50.9
1.0	3.3	6.0	19.7	11.0	36.1	16.0	52.5
1.5	4.9	6.5	21.3	11.5	37.7	16.5	54.1
2.0	6.6	7.0	23.0	12.0	39.4	17.0	55.8
2.5	8.2	7.5	24.6	12.5	41.0	17.5	57.4
3.0	9.8	8.0	26.2	13.0	42.7	18.0	59.1
3.5	11.5	8.5	27.9	13.5	44.3	18.5	60.7
4.0	13.1	9.0	29.5	14.0	45.9	19.0	62.3
4.5	14.8	9.5	31.2	14.5	47.6	19.5	64.0
5.0	16.4	10.0	32.8	15.0	49.2	20.0	65.6

<sup>1</sup> Copied, by permission, from "The Free Atmosphere in the Region of the British Isles" (Meteorological Office Publications, No. 202), 1909.

<sup>2</sup> The above table may be used also for converting heights expressed in English feet into kilometres by suitably adjusting the decimal point—e.g., 45,000 feet=13.7 kilometres; 6,700 feet=2.04 kilometres. (1 kilometre=1,000 metres.)



B. TEMPERATURE MEASUREMENTS.

CONVERSION OF DEGREES CENTIGRADE AND FAHRENHEIT INTO DEGREES ABSOLUTE (FREEZING-POINT=273° A).

C.	A.	F.	C.	A.	F.	C.	A.	F.	C.	A.	F.
-73	200	-99.4	-48	225	-54.4	-23	250	-9.4	+2	275	+35.6
-72	01	97.6	47	26	52.6	22	51	7.6	3	76	37.4
71	02	95.8	46	27	50.8	21	52	5.8	4	77	39.2
70	03	94.0	45	28	49.0	20	53	4.0	5	78	41.0
69	04	92.2	44	29	47.2	19	54	2.2	6	79	42.8
68	05	90.4	43	30	45.4	18	55	0.4	7	80	44.6
67	06	88.6	42	31	43.6	17	56	1.4	8	81	46.4
66	07	86.8	41	32	41.8	16	57	3.2	9	82	48.2
65	08	85.0	40	33	40.0	15	58	5.0	10	83	50.0
64	09	83.2	39	34	38.2	14	59	6.8	11	84	51.8
63	10	81.4	38	35	36.4	13	60	8.6	12	85	53.6
62	11	79.6	37	36	34.6	12	61	10.4	13	86	55.4
61	12	77.8	36	37	32.8	11	62	12.2	14	87	57.2
60	13	76.0	35	38	31.0	10	63	14.0	15	88	59.0
59	14	74.2	34	39	29.2	9	64	15.8	16	89	60.8
58	15	72.4	33	40	27.4	8	65	17.6	17	90	62.6
57	16	70.6	32	41	25.6	7	66	19.4	18	91	64.4
56	17	68.8	31	42	23.8	6	67	21.2	19	92	66.2
55	18	67.0	30	43	22.0	5	68	23.0	20	93	68.0
54	19	65.2	29	44	20.2	4	69	24.8	21	94	69.8
53	20	63.4	28	45	18.4	3	70	26.6	22	95	71.6
52	21	61.6	27	46	16.6	2	71	28.4	23	96	73.4
51	22	59.8	26	47	14.8	-1	72	30.2	24	97	75.2
50	23	58.0	25	48	13.0	0	73	32.0	25	98	77.0
-49	224	-56.2	-24	249	-11.2	+1	274	+33.8	+26	299	+78.8

## APPENDIX V

### BIBLIOGRAPHY OF SNOW-ROLLERS

THE Editors of the *Quarterly Journal of the Royal Meteorological Society* give the following references to descriptions of phenomena which throw further light upon the formation of the snow-rollers which are described at page 251 :

*Handy Book of Meteorology*. By Alexander Buchan, second edition, pp. 202, 203. 1868. (Snow-rollers observed by the Rev. Charles Clouston, Sandwick, Orkney, about 9 p.m. on March 5, 1862.)

*Nature*, vol. xxvii., p. 483. 1883. (A "Remarkable Phenomenon—Natural Snowballs," an account furnished to the *Courant* newspaper of February 22, 1883, by Mr. Samuel Hart, Trinity College, Hartford, Conn., U.S.A.)

*Nature*, vol. xxvii., p. 507. 1883. (Letter from Mr. G. J. Symons, referring to a letter from the late Admiral Sir F. W. Grey, which appeared in the *Meteorological Magazine* for May, 1876. The Admiral observed masses of snow, like boulders, at Lynwood, Sunningdale, Staines, after the snowstorm of Thursday night, April 13, 1876.)

*Symons's Monthly Meteorological Magazine*, vol. xx., p. 7. 1885. (Snow-rollers observed by Mr. H. Mellish, F.R.Met.Soc., at Hodsock Priory, Worksop, on January 12 and 13, 1885.)

*U.S. Monthly Weather Review*, vol. xxxiv., pp. 325, 326. 1906. (Snow-rollers observed during the night of January 18, 1906, by Mr. Wilson A. Bentley, at Jericho, Vt. The snow-rolls were formed as the temperature rose slowly from 24° to 34° F., and the lower wind shifted from westerly to southerly points, and blew at times in gusts.)

*U.S. Monthly Weather Review*, vol. xxxiv., p. 326. 1906. (Snow-rollers observed at Mount Pleasant, Michigan, by Professor R. D. Calkins, after a light flaky snow on the evening of January 17, 1906.)

*U.S. Monthly Weather Review*, vol. xxxv., pp. 70, 71. 1907. (Snow-rollers noted at Canton, New York, by M. L. Fuller, on February 19, 1907.)

## INDEX OF SUBJECTS AND PLACES

- ABSOLUTE** humidity, 186, 199  
**Accumulated** temperature, 36, 351  
**Actinometer**, 98; Herschel's, 98, 102; Richard's, 102, 103; Angström's electric compensation pyrheliometer and, 102  
**Acute** infective diseases, 409, 431  
**Adiabatic**, meaning of term, 338; atmosphere, 343; cooling of ascending air-currents, 363  
**Advective** region of atmosphere, 338, 343  
**Aéronautics**, International Commission of Scientific, 327  
**Africa**, aérological expedition to Tropical East, 344, 345  
**Air** temperatures of the British Islands, 386  
**Air-trap** in a barometer, 125  
**Air**, weight of, 13; liquefaction of, 14; freezing of, 14; elasticity of, 15; rarefaction of, 16; volumetric analyses of, 19, 20; a mechanical mixture, 20, 21; composition of, at great altitudes, 347, 348; temperature and its measurement, 75; capacity for containing aqueous vapour, 166; supersaturated, 195-197  
**Air-meter**, 277  
**Aitken's** dust-counters and koni-scope, 198  
**Alcohol**, specific heat of, 86  
**Allotropic** oxygen, 321  
**Altazimuth** anemometer, Casella's, 280  
**Altitude**, barometric correction for, 143, 148-150  
     effect of, on rainfall, 239, 240, 241  
     on temperature, 99, 100, 352, 353  
**Altitude**, effect of, on electric tension 301; on climate, 352, 353  
**Altitudes**, measurement of, 136, 137; composition of air at great, 347, 348  
**Alto-cumulus** cloud, 212  
**Alto-stratus** cloud, 212  
**American** Arctic current, 360, 361  
*American Weather*, General Greely's, 68  
**Ammonia** in air, 19, 23  
**Ammonium sulphide** in air, 19, 23  
**Amount** of cloud, 41  
**Ampère**, 306  
**Anemobarometer**, Wilke's, 271  
**Anémo-cinémographe**, Richard's, 285-288  
**Anemograph**, Casella's, 269, 289; Beckley, 285; stations, 29  
**Anemometers**, 265; history of, 269; pendulum, 270; Wild's, 270, 271; bridled, 271; pressure plate, 271; torsion, 271; Osler's, 271, 287; Dines's, 271, 284; Patent Pressure Portable, 271, 272, 273; pressure on a fluid, 273, 274; Lind's, 273, 274, 289; velocity, 274; hemispherical cup, 274; Robinson's, 271, 274-276, 287, 289; "step," 275, 276; current-meter, 277; air-meter, 277; evaporation or temperature, 277; suction, 278; Hagemann's, 278, 289; direction, 279; Lomonosow's, 279; inclination, 279; Casella's self-recording, 269, 289; Casella's altazimuth, 280; musical, 284; helicoid, 284; Richard's, 285; Kew pattern, 285, 287, 289  
**Anemometry**, 265; history of, 269, 270

- Anemoscope, Pickering's, 270 ;  
Laughton's feather-vane, 283
- Aneroid barometer, 132-134 ; draw-  
backs to its use, 134 ; engineer-  
ing, 137  
barograph, 129
- Annual barometric variations, 151,  
156  
*Climatological Report, Canada*, 71,  
72  
march of electrical tension, 301  
rainfall of the British Islands, 395 ;  
mean, of the world, 221  
range of temperature, laws of dis-  
tribution of, 355, 356
- Antarctic, Atlantic current, 361  
Continent, why constantly snow-  
covered, 371  
Expedition of 1902-04, 371
- Anticyclones, 9, 156, 157, 158, 160,  
164, 379, 380, 381
- Anticyclonic, 4, 160, 379, 380, 381  
circulation of air, 6, 17, 157,  
158 ; barometric variations,  
151, 160  
system contrasted with cyclonic,  
161 ; clouds in, 210  
weather, in winter, 157, 158 ; in  
summer, 164  
"Anti-trades," 266
- Antozone, 322, 324
- Antozonides, 322
- Aphelion, 99
- Apjohn's formula, 182, 183
- Appendices I. to V., 459-466
- April, mean temperature of, 389, 390
- Aquimeter, 179, 180
- Aqueous vapour, atmosphere of,  
165, 175, 190, 205, 220  
vapour in the air, 19, 25, 354 ;  
tension of, 151, 152, 165, 175,  
181, 186 ; where most abun-  
dant, 186
- Arctic circle, diurnal range of pres-  
sure in, 151, 153
- Argon, 19, 22, 347, 348
- Asia, climate of, 156, 354, 355, 367  
378, 379
- Asiatic cholera, 410, 416
- Athermancy, 18
- Atlas International des Nuages*, 213
- Atlas, meteorological, of the British  
Isles, 383, 388, 389, 392, 393,  
396
- Atmidometers, 167, 168
- Atmidometry, 166
- Atmometry, 166
- Atmosphere, definition of, 11 ; its  
physical properties, 11 ; its  
height, 17, 117-118 ; its trans-  
parency and diathermancy, 17 ;  
its composition, 19 ; of aqueous  
vapour, 165, 175, 190, 205, 220 ;  
dampness of, 186 ; in a constant  
state of electric tension, 301  
inversion of temperature in upper,  
100, 331  
isothermal layer of, 100, 331, 336,  
343, 345  
upper, investigation of the, 325-  
349
- Atmospheric air, weight of, 13 ;  
liquefaction of, 14 ; freezing of,  
14 ; elasticity of, 15 ; rarefac-  
tion of, 16 ; where purest, 19 ;  
its composition, 19 ; a mechani-  
cal mixture, 20, 21  
dust, 195-198 ; composition of,  
197  
electricity, 293, 308 ; nature of,  
295 ; its phenomena, 296 ; in  
the production of rain, 243-246  
pressure, 17, 114 ; how measured,  
114 ; distribution of, in Canada,  
158 ; extremes of, 120, 121 ;  
variations in, 151 ; influence of  
aqueous vapour on, 165, 166 ;  
in British Islands, 392 ; in  
Dublin, 402 ; periodicity of, 408
- Atomic theory of Dalton, 15
- Attached thermometer, 139
- Attraction, capillary, 140 ; electri-  
cal, 295
- Aurora, 294, 296, 314 ; borealis, 296,  
314 ; australis, 296, 314 ; distri-  
bution of, 314 ; periodicity of,  
314 ; explanation of, 315 ; height  
of, 315 ; tints of, 315
- Australian "brickfielders," 375 ;  
"burstors," 375
- Autumnal distribution of disease,  
417-419  
fever, 431
- Average mean temperature, 94
- Axis of rotation, Earth's, 4, 5, 11, 12,  
151
- BABINGTON'S atmidometer, 168
- Bacillus pneumoniæ* of Friedländer,  
456
- Backing of wind, 163
- Bacteriology of summer diarrhœa,  
425, 426
- Balance-pattern rain-gauges, 233, 234



- Ball lightning, 308, 310  
 Balloon ascents for meteorological purposes, 46, 67, 100, 185, 325 ; wet-bulb readings during, 185  
*Balloons-sondes*, 327  
 Barograph, 126 ; meaning of the term, 126 ; King's, 126, 127 ; Ronalds's photographic, 128 ; Redier's mechanical, 128 ; electric, 128, 129 ; aneroid, 129, 130  
 Barometer, 26, 114 ; history of the, 118, 119 ; meaning of the word, 114 ; uses of the instrument, 114 ; its discovery, 115 ; its construction, 120 ; mercurial, 116 ; 120, 121, 122 ; glycerine, 116, 117 ; wheel, 119, 126 ; extreme readings of, 120, 121 ; mounting, 122 ; Wollaston's differential, 274  
   aneroid, 132, 133, 134 ; holosteric, 132 ; metallic, 133  
   corrections to be applied to readings of, 122, 140, 143-150  
   how to be mounted, 139  
   readings, 139  
   scale, 143  
     adjustment of, Wallis's, 123, 124  
 Standard, or Fortin, 123  
 Kew, 123, 124, 125  
 siphon, 123, 125  
 Fitzroy, or "gun," 125  
 self-registering, 126  
 Bartrum's open-scale, 131, 132  
 piezmic, 134, 135  
 Dines's self-recording mercurial, 135, 136  
 sympiesometer, 137  
 Barrett's open-scale, 138  
 Bourdon tube, 133, 328  
 variations in height of, 151  
 Barometrical fluctuations, 151  
   gradients, 7, 8, 265  
 Baroscope, 119  
 Barton Moss Evaporation Station, 34, 172  
 Base temperature, 35  
 Beaded lightning, 309  
 Bearings, how determined by compass, 267 ; by the pole star, 268 ; by the sun, 268  
 Beaufort scale of wind force, 32, 36, 38, 39, 40, 266 ; of weather, 32  
 Beckley anemograph, 285  
 Beech-trees and lightning, 311  
 Behring's Straits current, 361  
 Belfast, rainfall in, 398  
 Bench-mark, Ordnance Survey, 148  
 Bergen, cholera at, 413-415 ; mean annual rainfall at, 262  
 Besson's nephometer, 218  
   comb nephoscope, 214  
   zenith nephoscope, 216  
 Bimetallic thermometer, 328  
 Black-bulb thermometer *in vacuo*, 101  
 "Black rain," 248  
 Blitzableiter, 317  
 "Blitzröhren," 310  
 Blizzard, 250  
 Blood-rain, 264  
 Blue Hill Observatory, U.S.A., 325, 327, 328  
 "Blue mists," 416  
 Bog of Allen, 390, 401  
 Bogs, influence of, on climate, 390, 401  
 Boiling-point of water, 76-79, 138, 194  
 Boomerang, principle of the, 13  
 Bora of Trieste and Dalmatia, 373  
 Bourdon tube thermometers, 327  
   tube barometer, 133, 328  
 Bourrasques, 380  
 Boyle's and Mariotte's law, 14  
 Bradford rain-gauge, 226  
 Breslau, cholera in, 413, 415  
 "Brickfielders," Australian, 375  
 Bridled anemometers, 271  
 Bright sunshine, duration of, 109  
 Bright-bulb thermometer *in vacuo*, 101  
 Brisbane, torrential rainfall in, 263  
 British Association for the Advancement of Science, 69, 91, 124, 178, 244, 293, 308, 325, 326, 327, 343, 385, 406  
 Islands, rainfall in, 261, 395  
   climate of, 289, 351, 378, 395 ;  
   gales in, 289-291 ; sea-temperatures round, 356, 383 ;  
   air-temperatures of, 386 ; atmospheric pressure in, 392  
 meteorological observations, 27, 28, 29  
 Meteorological Office, 7, 28, 29, 30, 33, 37, 38, 40, 109, 128, 129, 148, 149, 150, 209, 225, 238, 266, 327, 348, 383, 388, 394  
 Meteorological Society. See Royal Meteorological Society  
*British Rainfall*, 33, 37, 170, 239, 261, 395

- Brocken, Spectre of the, 203  
 Bronchitis, seasonal prevalence of, 448, 449, 451-455  
 Brontometer, 320, 321  
 Brush discharge and St. Elmo's fire, 312  
 Bulb, forked or cylindrical thermometer, 86, 104  
 Bunsen flame, 24  
 Bureau, United States Weather, 44-68, 70; its cost, 48; its departments, 48-51; its library, 51, 52; its regular stations, 52, 54; its publications, 50, 51  
 Bureaux, weather, 27  
 Burning sunshine recorder, 109  
 "Bursts," Australian, 375  
 Buys Ballot's law, 4, 6, 9, 157, 158, 159, 265, 378  
  
**CALIBRATING** thermometer tubes, 80  
 Calm, meaning of the term, 4, 268  
 Campbell-Stokes sunshine recorder, 109-110  
 Canada, climate of, 351, 356  
   meteorological observers in, 70, 71  
   telegraph-reporting stations in, 70, 71, 72  
   storm-signal stations in, 70, 71, 72  
   climatological stations in (1907), 72  
   atmospheric pressure, distribution of, in, 158  
 Canadian Meteorological Service, 69-74  
   establishment and development of, 69-72  
   publications of, 72  
   cost of, 70  
   grant to (1909), 72  
   weather forecasts of, 70, 71, 72-74  
   Director of, 69, 71  
   Central Office and Observatory of, Toronto, 69, 72, 74  
   equipment and work of, in 1907, 72  
   snow and drift warnings by, 73, 74  
   storm-warnings by, 70, 73, 74  
 Cancer, Tropic of, 12  
 Capacity correction in barometers, 122, 143, 144, 146  
 Capillarity, correction for, 140, 143, 147  
 Capillary action in barometer, 140  
   attraction, 140; repulsion, 140  
 Capricorn, Tropic of, 12  
  
 Carbon dioxide in air, 19-22; whence derived, 21  
 Carse clay, 400  
 Casella's mercurial minimum thermometer, 85, 86, 87-89  
   electrical rain-gauge, 229  
   self-recording anemometer, 269, 289; air-meter, 277; altazimuth anemometer, 280-283  
   self-registering earth-thermometer, 105, 106  
   solar radiation maximum thermometer, 102; bifurcated grass-minimum thermometer, 104, 105  
 Castor and Pollux, 312  
 Cathetometer, 144-146  
 Cautionary signals, 62, 63, 64  
 Celsius' thermometer scale, 77-80  
 Centigrade thermometer, 15, 77-80  
 Centrifugal force, 16  
 Chalk, 401  
 Chapletted lightning, 309  
 Charles's law, 15, 16  
 Charts, weather, 27, 31, 32, 45, 51, 55, 56, 57, 67, 70, 71, 72, 73  
   underground temperature, 107-109  
   Jordan barometer, 117  
   diurnal oscillation of the barometer in various latitudes, 155  
   cyclonic and anticyclonic isobars, 160  
   synoptic weather, 27, 35, 160  
   "Chasse-neige," 252  
 Chemical hygrometers, 178, 179  
 Cherrapunji, rainfall at, 220, 262, 263  
 Chief of the United States Weather Bureau, 46, 48  
   Signal Officer, United States, 45, 46, 52  
*Chinook* wind of the Canadian prairies, 261, 262, 353, 375  
 Chlorophyll, chemical action of, 22  
 Cholera, 413-417; and subsoil temperature, 109; and ozone, 323, 324, 415; and subsoil water, 364  
   Asiatic, 410, 416  
   "Cholera blasts," 416  
   "Cholera clouds," 416  
   infantum, 423, 424  
   *nostras*, 416  
   seasonal prevalence of, 413-417  
 Cholerine and subsoil temperature, 106-109, 416  
 Christiania, cholera in, 415

- Cirro-cumulus cloud, 205, 207, 212  
 Cirro-stratus cloud, 205, 206, 210, 211, 212  
 Cirrus cloud, 205, 206, 212 ; an aid in forecasting, 20 ;  
 Cistern, barometer, 120, 122  
 City fog, 200-202  
 Classification of clouds, 205, 211, 212  
   gales, 290  
   thunderstorms, 302  
   winds, 372  
 Clays, influence of, on climate, 363, 400, 401  
 Climate, 350, 362 ; meaning of the word, 350 ; influence of radiation upon, 100 ; influence of forests upon, 365-368 ; on what it depends, 351, 352  
   and weather, 350  
   definitions of, 350, 351 ; insular and continental, 354, 378 ; moderate and excessive, 354, 378  
   of the British Islands, 378, 395 ; mild winter, of Devon and Cornwall, 384, 385 ; influence of soils on, 400  
 Climatological observatories, 28, 33, 382 ; in Canada (1907), 72  
   Tables for Dublin, 402, 404-406  
 Climatology, 3, 53, 67, 350, 354, 378, 382, 383  
 Cloud, 190, 205  
   amount of, 41 ; scale for, 211  
 Cloud-atlas, 211, 213  
 Cloud-line, 205  
 Cloud-slopes in cumulus, 209, 210  
 Clouds, classification of, 205, 206, 211, 212 ; contractions used in recording observations on, 211 ; electrical state of, 302  
 Clouds, 205 ; photographs of, 67 ; height of, 205, 206  
   formation of, by mountains, 202, 203  
   fine-weather, 212 ; bad-weather, 212  
   upper, 206 ; lower, 206, 207  
 Cloudy condensation in air, 193, 194, 195  
 Code, International, 41, 42 ; United States Weather, 54, 59  
 Coefficient of expansion of a gas, 15  
   for obtaining mean temperatures, 94  
 " Col " of high pressure, 161  
 " Cold wave," 56  
   winds, 372-374  
 Collector, electrical, 297-298  
 Colorado, climate of, 362  
 Colour of lightning, 312, 313  
 Colour phenomena from dust, 198, 199  
 Coloured rain, 247-249  
 Combustion dust, 197  
 Comma bacillus of cholera, 416  
 Committee, Meteorological, 33, 93, 149, 183, 289, 292, 296, 334, 383, 388, 396  
 Comozants, 312  
 Compass bearings compared with true bearings, 267  
 Composition of the atmosphere, 19  
 Compression, measure, 137  
   of gases, law of, 14  
 Condensation, 190 ; its various forms, 190  
 Conduction of heat, 96  
 Conductors, lightning, 317  
 Conference, International Meteorological, 8, 102, 181, 211, 216, 225, 268, 270, 287, 296, 321  
 Configuration of surface, influence of, on climate, 357  
 Conservation of solar energy, 98  
 Consumption and subsoil drainage, 364  
 Continental climate, 354, 378  
 Contractions used in cloud observations, 211  
 Convection of heat, 96, 97  
 Convective region of atmosphere, 338, 343  
 Coronæ, 206  
 Corporants, 312  
 Corrections in barometer readings, 122, 140, 143-150  
 Cost of United States Weather Service, 45  
 Coulomb's torsion balance electrometer, 298, 299  
 " Critical " temperature of the soil, 109, 416, 417, 423, 434  
 Crosley's registering rain-gauge, 229  
 Crova's hygrometer, 187, 188  
 Crystalline rocks, 400, 402  
 Crystals, snow, 249, 250 ; ice, 206, 207, 254  
 Cumulo-cirro-stratus cloud, 210  
 Cumulo-nimbus, 212  
 Cumulo-stratus cloud, 206, 207, 210

- Cumulus cloud, 205, 207, 208, 210, 212; formation of, 208; festooned, 209; cloud slopes in, 209, 210
- "Curing" thermometer tubes, 81
- Current meter anemometer, 277
- Currents, inclined air, 279
- Cyclones, 9, 157, 158, 160-163, 257, 303, 304
- Cyclonic, 4, 160; system, 5, 378, 380; clouds in, 206, 210, 211; contrasted with anticyclonic, 161; circulation of air, 5, 6, 156-158; barometric variations, 151, 160
- thunderstorms, 302, 313
- DAILY Weather Bulletin, Canada, The, 71
- weather charts, 27, 31, 32, 55, 67
- Weather Map, Toronto, 71, 72
- Weather Report, The, 31, 32, 34, 38
- weather reports, 31, 32, 34, 35
- Daniell's hygrometer, 175; galvanic battery, 300
- Dates in the history of the United States Weather Service, 46, 47
- Datum, Ordnance Survey, 148
- Day degrees, 36, 351; meaning of term, 36
- Daylight Recorder, Jordan's, 111
- De la Rue's evaporimeter, 169
- Density, electrical, 296
- of buildings a cause of diarrhœa, 424
- Depression, atmospheric, 156, 159
- secondary or subsidiary, 161, 304
- thunderstorm, 255, 303, 304
- V-shaped, 161
- Devon and Cornwall, mild winter climate of, 384, 385
- Dew, 99, 175, 176, 184, 190-192, 220; theories of, 190, 191; its measurement, 192, 220; its formation interfered with, 192
- Dew-point, 175-178, 181, 183, 184; mode of determining, 183
- Diarrhœa and subsoil temperature, 106-109, 417
- Diarrhœal diseases, 417; nature and action of the poison of, 425; bacteriology of, 425, 426; house-flies and, 427-430; investigations in New York, 427-429; investigations in England, 430
- Diathermancy, 17, 18, 370; meaning of term, 17
- Differential barometer, Wollaston's, 274
- Diffused lightning, 308, 310
- Diffusion of gases, 23, 24
- Dines's helicoid anemometer, 284; hygrometer, 175, 177-178; patent pressure portable anemometer, 271; light meteorographs, 329, 330
- Diplococcus pneumoniae* of Fränkel, 456
- Diploma in State Medicine, 3
- Direct hygrometers, 175
- Direction of wind, 38, 267; how determined, 7, 267; Lambert's formula for, 287; true, not magnetic, 41, 267
- anemometers, 279
- Disease, influence of season and weather on, 409
- registration, necessity for, 455
- Diseases, acute infective, 409, 410, 431
- Displacement of zero, 81, 82
- Distribution of forecasts in United States, 61
- of rain, 249, 260-263
- Diurnal barometric variations, 151
- march of electricity, 301
- rainfall, 263
- Drainage, subsoil, and consumption, 364
- Dry-bulb thermometer, 148, 181
- Dry smoke fog, 193, 201
- Dublin, extremes of atmospheric pressure in, 120, 121; diurnal range of atmospheric pressure in, 153; hail-storm in, 255-257; rainfall in, 261, 263, 363, 397, 398, 399, 402, 404; heavy rains in, 263; mean temperatures in, 354, 355, 388, 402, 404; storm of February, 1903, in, 13, 290; climate of, 362, 363, 385, 386; climatological tables for, 402, 404-406; influenza epidemic in, 410; cholera in, 415; diarrhœal diseases in, 417-419, 421; enteric fever in, 431-434; typhus in, 435, 436; smallpox in, 439; measles in, 441, 442, 444; scarlatina in, 443-445; pneumonic fever in, 446, 448, 449; bronchitis in, 449, 451-455
- Dust as a condenser of aqueous vapour in air, 195, 196, 243



- Dust-counter, Aitken's, 198  
 Dust-fall, 264  
 Dust haze, 203  
 Dust particles in air, 195-198 ; composition of, 197 ; colour-phenomena from, 198, 199 ; number in atmosphere, 199  
   water, 205 ; snow, 250, 252  
 Dysentery and ozone, 323
- EARTH temperatures, 105-109  
   thermometer, Symons's, 105 ; Casella's, 105, 106  
 Earth's axis of rotation, 4, 5, 11, 12, 151  
 Easterly winds of spring, 373 ; why so cold, 372  
 Ebullition, 79  
 Eccentricity of the earth's orbit, 98, 99  
 Ecliptic, 11  
 Edinburgh, mean temperature of, 388 ; rainfall in, 398  
 Egnell's law, 344  
 Elastic force of aqueous vapour, 151, 152, 165, 175, 181, 186  
 Elasticity of air, 15  
 Electric kites, 294, 306  
 Electrical barographs, 128, 129  
   collector, 297 ; Volta's, 297 ; Thomson's water-dropping, 298  
   density, 296  
   dew-point hygrometer, 178  
   force, 296, 298  
   induction, 297  
   intensity, 296, 298 ; diurnal and annual march of, 301  
   potential, 296, 298, 311  
   replenisher, 300  
   self-registering rain-gauges, 229-233  
   state of the upper atmosphere, 306, 307  
   tension, 296, 298 ; diurnal and annual march of, 301 ; effect of altitude on, 301  
   thermographs, 92, 93  
 Electricity, atmospheric, 293, 308 ; nature of, 295 ; phenomena attending, 296  
   compared with heat, 295  
   convection of, 97  
   diurnal march of, 301  
   in the production of rain, 243-246  
   negative, 296, 302, 305, 306  
   positive, 296, 302, 306  
   resinous, 295, 296
- Electricity, transmission of barometric indications by, 130  
   vitreous, 295  
 Electrified bodies, 295  
 Electrodes, 299  
 Electro-magnetic theory of light, 293, 294  
 Electrometer, 298 ; Thomson's Quadrant, 299 ; Thomson's Portable, 299, 300 ; photographic, 300 ; Peltier's, 301  
 Electro-motive force, 298 ; expressed in "volts," 300  
 Electrons, 316  
 Electrophorus, 299  
 Electroscope, 295 ; described, 297  
 Elevation, effect of, on boiling-point, 79, 138 ; on temperature, 99, 100  
 Engineering aneroid, 137  
 England, thunderstorms in, 305 ; distribution of rainfall in, 261, 396-399 ; mean temperatures of, 386-390 ; soils in, 400, 401 ; scarlet fever in, 443, 445  
 Enteric fever and subsoil temperature, 109 ; and subsoil water, 364  
   fever and its seasonal prevalence, 431, 434  
   feverishness in, 457  
 "Epidemic constitution," 410, 416  
 influenza, 410-412  
   summer diarrhoea and subsoil temperature, 106-109, 417  
 Equation of time, 268  
 Equator, 11 ; distance from the, as influencing climate, 351  
   snow and ice under the, 353  
 Equinoctial gales, 394  
   points, 11  
 Equinoxes, 11  
 Equivalence, law of, 360  
 "Error of capacity," 122  
 Errors of parallax, in barometer readings, 141 ; in rainfall readings, 239  
 Etesian winds of south-eastern Europe, 374  
*Étincelle de rupture*, 93  
 Europe, thunderstorms in, 305 ; climate of, 156, 157, 354, 367, 368, 378, 379  
 Evaporation, 166 ; coolness produced by, 167 ; force of, 184  
   investigations in England, 172 ; in the United States, 172, 173, 174

- Evaporation, anemometer, 277, 278  
 in London, 170 ; in Ireland, 171  
 "Evaporation" rains, 262  
 Evaporimeters, 167 ; de la Rue's,  
 169 ; Pickering's Patent Stan-  
 dard, 170  
 Excessive climates, 378  
 Expansion of air, 14 ; coefficient of,  
 15  
 Exposure of rain-gauge, 238  
 Extremes of atmospheric pressure,  
 120, 121
- FACTORS, Glaisher's, 183, 184, 460 ;  
 Greenwich, 183  
 Fahrenheit's thermometer, 15, 76-  
 78, 80, 351  
 "Fall Fever," 431  
 Fauna, influence of climate on, 350,  
 351  
 Feather-vane anemoscope, Laugh-  
 ton's, 283  
 Fernley Observatory, Southport, 33,  
 34  
 Festeoned cloud, 209  
 Fever, enteric, and subsoil tempera-  
 ture, 109 ; and subsoil water, 364  
 pneumonic, seasonal prevalence  
 of, 446 ; in Dublin, 446  
 Fiducial point in Standard Baro-  
 meter, 123, 140  
 Filling thermometer tubes, 80  
 Fineman's nephoscope, 213, 214  
 Fire-balls, electrical, 310  
 Fire-damp in air, 23  
 Fire, St. Elmo's, 312  
 Firn, 370  
 Fitzroy barometer, 125  
 Flag-signals in United States, 63, 64  
 Flash, the green, 459  
 Flies and diarrhoeal diseases, 427-  
 430  
 Float pattern rain-gauges, 226, 233  
 Floods in American rivers, 60, 61  
 Flora, influence of climate on, 350,  
 351  
 Fog, 165, 190, 193 ; varieties of, 193 ;  
 formation of, 193, 194, 200  
 wet, 193 ; dry smoke, 193, 201  
 Fog densities, measurement of, 204  
 "Fog scoffers," 204  
 Föhn wind of north-east Switzer-  
 land, 261, 353, 354, 375 ; the  
 "snow-devourer," 354  
 Fomites, 427  
 Food-keeping, defective, and diar-  
 rhœa, 424
- Force of wind, how determined, 7,  
 38, 39, 265, 266 ; Beaufort  
 Scale, 32, 36, 38-40, 266  
 evaporation, 184 ; electricity, 296 ;  
 electro-motive, 298, 300  
 Forchhammer process, 24, 25  
 Forecast Division of United States  
 Weather Bureau, 45, 46, 48, 49,  
 53-61  
 Forecasting, cirrus observations an  
 aid to, 206  
 Forecasts, 10, 27, 31, 45, 46, 48, 49,  
 53-61, 64, 65, 66, 70, 71, 72-74,  
 114  
 in Canada, 72-74  
 distribution of, in United States,  
 61-65  
 Forests, influence of, on climate,  
 365-368  
 Forked lightning, 308  
 thermometer bulb, 86, 104  
 Formula for reduction of barometer  
 readings, 148, 149, 150  
 Fortin barometer, 122-124, 139, 143,  
 144  
 "Free air," 8, 265  
 Free water surfaces, 167, 193, 194  
 Freezing, mixtures, 76  
 point of water, 76, 79, 194  
 Friction, development of electricity,  
 by, 295  
 Frost of 1890-91, 164  
 glazed, 191, 192, 254  
 hard, in British Islands, 380, 381  
 Frozen air, 14 ; nitrogen, 14  
 rain, 192, 254  
 Fulgurite, 310  
 Fulminary tube, 310
- GALES, classification of, 38, 39, 40,  
 290  
 equinoctial, 394  
 and strong winds compared, 290  
 Galvanic battery, Daniell's, 300  
 Gas, definition of a, 13 ; liquefaction  
 of, 14 ; compression of, 13, 14 ;  
 diffusion of, 23  
 Gases, laws relating to, 14, 23  
 condensed, in atmosphere, 197  
 Gauge, evaporation, de la Rue's  
 self-recording, 169  
 rain, history of the, 223-225 ; best  
 form of, 225 ; Hooke's, 224  
 float, 226, 233 ; storm, 226 ; Ne-  
 gretti and Zambra's, 228 ; self-  
 recording, 228-237 ; Crosley's  
 registering, 229 ; Yeates's elec-

- tric self-registering, 229; Casella's electrical, 229; advantages of, 230, 232; Richard's self-recording, 233; Meteorological Office, 225; Snowdon, 226; Bradford, 226; Halliwell's Patent, 235; snow-melting, 253 position of, 238  
 Geographical distribution of rain, 260, 261, 395  
 Geological formation as influencing British climate, 399  
 Givre, 191  
 Glaisher's hygrometrical tables, 183, 460  
     factors, 183, 184, 460  
 Glasnevin Observatory, 404, 407  
 Glass, weather, 119, 126  
 Glatteis, 192, 254  
 Glazed frost, 191, 192, 254  
 Globular lightning, 308, 310  
 Glossop Observatory, 306  
     Upper Air Investigation Station, 327, 333  
 Glycerine, specific gravity of, 116  
     barometer, 116, 117  
 Gold-leaf electroscope, 295; described, 297  
 Gradients, barometrical, 7, 8, 265  
     thermometric, 380  
 Graduation of thermometer tubes, 81  
     barometer scale, 141-143  
 Graham's Law, 23  
 Grass-minimum thermometer, Casella's bifurcated, 104, 105  
 Graupel, 258  
 Gravity, correction for, in reading the barometer, 143, 150  
     specific, 115, 117  
 Great Britain, rainfall in, 261; thunderstorms in, 305, 306; temperature in, 386-390  
 Green Flash, 459  
 Green snow, 249; its cause, 249  
 Greenwich Observatory, 28, 93, 119, 300  
     factors, 183  
     time, conversion of, to local, 268  
 Grêle, 255  
 Grésil, 258  
 Ground fog, 205, 207  
     frost, 191, 192, 254  
 Grundwasser, 416  
 Gulf Stream, 359; its climatic effect, 359, 360  
 Gun Barometer, 125  
 Gusts, 290  
 Gyrotory movement of air, 4, 6  
 HAGEL, 255  
 Hagemann's anemometer, 278, 289  
 Hail, 190, 249, 255; its formation, 255, 259, 260; soft, 258; weight of, 258, 259; shape of, 259; its relation to electricity, 296, 313, 314  
 Hailstorms, 255-260, 313, 369  
 Hair hygrometer, 178; used in winter in Russia, 185  
 Halliwell's patent rain-gauge, 235  
 Halos, solar and lunar, 163, 206, 207  
 Hard frosts in British Islands, 380, 381  
 Harmattan of the west coast of Africa, 374  
 Hauling of wind, 163  
 Haze, 199, 203; dust, 203  
 Health and weather, 2  
     influence of temperature of the soil on, 106-109  
     Medical Officers of, 42  
 Heat, and electricity compared, 295  
     conduction of, 96  
     convection of, 96, 97  
     definition of specific, 356  
     how transmitted, 96-98  
     latent, 167  
     radiant, 17, 18, 97  
     radiation of, 96, 97, 98  
     specific, of mercury, 86; alcohol, 86; water, 100, 356  
     unit, 359  
 Heat-waves, 17, 18; thunderstorms, 302, 303  
 Height of the atmosphere, 17, 117, 118  
     of barometer, 125  
     of clouds, 205, 206  
     of columns of liquids or gases inversely proportional to their specific gravity, 115, 117  
 Helicoid anemometer, 284  
     surface, meaning of the term, 284  
 Helio-pyrometer, 101-102  
 Helium in air, 22, 23, 347, 348  
 Hemispheres, Magdeburg, 17  
 Hemispherical cup anemometer, 274  
 High-pressure areas, 156, 160  
 Himalayas, climate of the, 353  
 Hoar frost, 190, 191, 220  
 Höhenrauch, 203  
 Holosteric barometer, 132  
 Hooke's rain-gauge, 224

- Hot wind of Australia, 375  
winds, 374, 375
- House-flies and diarrhoeal diseases, 427-430
- Humboldt's current, 361
- Humidity, 42  
absolute, 186, 199  
and disease, 410  
relative, 181, 184, 199
- Humus, definition of, 363 ; influence on climate, 363, 364
- Hurricanes, West India, 162
- Hydrogen sulphide in air, 19, 23
- Hyetal equator, 260
- Hyetograph, Negretti and Zambra's, 234
- Hyetometry, 166, 190, 220 ; meaning of term, 190
- Hygrometers, 175 ; direct, 175 ; indirect, 175, 178 ; organic, 175 ; inorganic, 175 ; Daniell's, 175, 183 ; Regnault's, 176 ; Dines's, 177 ; an electrical dew-point, 178 ; de Saussure's, 178 ; chemical, 178, 179 ; a gravimetric recording, 179 ; dry and wet bulb, 181 ; Mason's, 181 ; Crova's, 187, 188 ; history of, 186
- Hygro-metrical tables, 182, 183, 460, 461
- Hygrometry, 166, 175
- Hygroscope, 178
- Hypsometer, 137, 138
- ICE, melting-point of, 76-80, 194 ; specific gravity of, 258, 259
- Icebergs, 360, 361  
as fog-producers, 202
- Ice-crystals, 206, 207, 254
- Iceland, winter thunderstorms in, 305  
"Inbat," 385
- Inch of rain, meaning of term, 263
- Inclination anemometers, 279
- Inclined currents, 279
- Index error, 43, 143, 144, 147
- Indian monsoons, 262, 372
- Indirect hygrometers, 178
- Induction, 297, 310, 312 ; phenomena caused by, 310, 312
- Infective diseases, acute, 409, 410, 431
- Influence of season and weather on disease, 409
- Influenza, 410-412
- Inland range of temperature, 358
- Innsbruck International Meteorological Conference, 102, 321
- Instrument Section of the United States Weather Bureau, 50
- Instruments required for Second Order Station, 42, 43
- Insular climate, 354, 378, 386
- Insulated, meaning of, 297
- Insulation, 297
- Intensity of cyclones, 162  
electricity, 296
- International - Balloon Ascents of July, 1907, 329-332  
Meteorological Committee, 38, 91, 212, 213, 252, 287, 296  
Meteorological Conference, 8, 38, 42, 102, 181, 211, 216, 225, 252, 268, 270, 287, 296, 321  
Code, 42
- Inversion of temperature, 100, 331
- Inverted cumulus cloud, 209
- Ionisation of atmospheric air, 245
- Ionised gases in production of rain, 244
- Ions, 245, 247 ; counting of, in rain-drops, 246
- Ireland, evaporation in, 171 ; rainfall in, 261, 396-399 ; thunderstorms in, 305 ; climate of, 357 ; mean temperatures of, 386-390 ; soils in, 401
- Irregular barometric variations, 151, 159, 160
- Isobars, 7, 157, 160, 265 ; meaning of term, 31 ; straight, 161 ; in thunderstorms, 303
- Isohyets, 221
- Isothermal layer of the atmosphere, 100, 331, 336, 343, 345, 346
- Isothermals, 379, 380 ; British, 383
- Isotherms, 31, 379, 380 ; meaning of term, 31
- Ivy on houses, 368, 369
- JAMAICA, thunderstorms in, 304
- January mean temperature, 389
- Jordan photographic sunshine recorder, 109, 111-113 ; improved ditto, 113  
glycerine barometer, 117 ; chart of, 117
- Journal of the Weather, Merle's, 26
- July mean temperature, 390
- KEW Observatory, 28, 37, 43, 82, 83, 101, 147, 276, 285, 300, 399  
anemograph, 285, 287, 289  
barograph, 93



- Kew Observatory barometer, 122-125, 140, 144, 147  
     thermometer, 83  
 Khamseen, or Khamsin, of Egypt, 374  
 Khasi Hills, rainfall in the, 220, 262, 263  
 Kilda, St., winter temperature in, 386  
 King's barograph, 126, 127  
 Kite, electric, 306  
     Franklin's electric, 294, 325  
 Kite-stations, 327, 333  
 Koniscope, or dust-detector, Aitken's, 198  
 Krypton, 22, 348  
  
 LAMBERT's formula for mean direction of wind, 287  
 Lamont's atmometer, 168  
 Land and sea breezes, 208, 209  
     and water, influence of, on climate, 352, 354-358  
 Land meteorology of the British Islands, 27, 28  
 Latent heat, 167 ; its use, 167  
 Latitude, influence of, on climate, 350-353  
 Law of Buys Ballot, 4, 6, 9, 157, 158, 159, 265  
     Boyle and Mariotte, 14, 16  
     Charles, 15, 16  
     Graham, 23  
     Regnault, 15, 16  
     Stefan, 341  
 Laws of electricity, 295, 296  
 Leipzig, International Meteorological Conference, 268  
 Lenkoran forest, 368  
 Leste of Madeira, 375  
 Leveche of the Iberian Peninsula, 374  
 Leyden jar, 299, 300  
 Library of the United States Weather Bureau, 51, 52  
 Light, vibrations of, 17  
     electro-magnetic theory of, 293, 294  
 Lightning, 308, 309 ; what it is, 308 ; its varieties, 308  
     zigzag or forked, 308, 309, 310 ; diffused, 308, 310 ; summer, 308, 310 ; sheet, 308, 310 ; globular, 308, 310 ; ball, 308, 310 ; tubes, 310  
     rapidity of, 311  
     colour of, 312, 313  
     conductors, 317, 318 ; their principle, 317 ; description of, 317, 318 ; conditions for an efficient, 318-320  
 Lightning-rod, 317 ; Conference, 318  
 Limestone soils, influence on climate, 400, 401  
     carboniferous, 401 ; oolitic, 401 ; ancient, 401  
 Lind's anemometer, 273, 274, 289  
 Liquefaction of gases by cold, 14  
 Local time, conversion of Greenwich to, 268  
 London clay, 401  
 London, diarrhoeal diseases in, 418, 423 ; mean temperature of, 388 ; smallpox in, 437, 438, 440 ; measles in, 441, 442 ; scarlatina in, 443, 445 ; pneumonic fever in, 449 ; bronchitis in, 449, 451-455  
     evaporation in, 170 ; remarkable rainfall in, 226  
     Fever Hospital, 435  
     Meteorological Office, 7, 28, 29, 30, 33, 37, 38, 40, 109, 128, 129, 148, 149, 150, 209, 225, 238, 266, 327, 348, 383, 388, 394  
 Lower clouds, 206, 207  
 Low-pressure areas, 4, 156, 160, 304  
 Luminous lightning, 309  
 Lunar halos, 163, 206, 207  
 Lungs, inflammation of the, 446, 448  
  
 MACKEREL sky, 206, 207  
 Magdeburg Hemispheres, 17  
 Magnetic bearings compared with true bearings, 267  
     parallel, 314 ; storms, 314  
     storm of September 25, 1909, 316  
 Magnetism, terrestrial, and aurora, 314, 316  
 Malaria, 364, 365  
 Maps, distribution of bright sunshine, 37  
     *Monthly Weather, Canada, The*, 72, 74  
     rainfall, 67, 221, 395, 396  
     weather, 27, 31, 32, 45, 51, 56, 57, 67, 70, 71, 72, 73  
 Mares' tails, 205  
 Marine barometer, 124  
 Marl, 422  
 Marsh-gas in air, 23  
 Marshy soils, influence of, on health, 364  
 Mason's hygrometer, 181  
 Matterhorn, 203  
 Maximum thermometers, 83-85

- Mean, direction of wind, Lambert's formula for, 287  
 temperature, 93, 94, 95 ; of British Islands, 386  
 reduction of, to sea-level, 387, 388, 390  
 and disease, 410  
 coefficients, 94, 95  
 how obtained, 94-95
- Meandering lightning, 309
- Measles, seasonal prevalence of, 440 ; in London, 441
- Measurement of altitudes, 136, 137, 150  
 fog densities, 204  
 rainfall, 238, 239  
 snow, 252, 253
- Mechanical barograph, Redier's, 128
- Medical Officers of Health, 42
- Medicine and meteorology, 2  
 State, Diploma in, 3
- Melting-point of ice, 76-80
- Meniscus, meaning of the term, 140
- Mercurial minimum thermometer, 85, 86, 87-89  
 barometer, 116
- Mercury, specific heat of, 86 ; specific gravity of, 116 ; as a medium for indicating temperature, 77, 82, 85, 86 ; atmospheric pressure, 115
- Merle's *Journal of the Weather*, 26, 27
- Metallic dust in air, 24 ; barometer, 133
- Meteoric dust, 197
- Meteorographs, 129, 327 ; Dines's light, 329, 330
- Meteorological Atlas of the British Isles, 383, 388, 389, 392, 393, 396  
 Committee, 33, 93, 149, 183, 289, 292, 296, 334, 383, 388, 396  
 Committee, International, 38, 91, 212, 213, 252, 287  
 Conference, International, 8, 38, 42, 102, 181, 211, 216, 225, 268, 270, 287, 296, 321  
 information bearing on public health, 331  
 observations, British, 26, 28  
 Office, London, 7, 28, 29, 30, 33, 37, 38, 40, 109, 128, 129, 148, 149, 150, 209, 225, 238, 266, 327, 348, 383, 388, 394
- Meteorological Service, Canadian, 69-74  
 Society, Royal, 28, 29, 33, 37, 89, 92, 101, 109, 118, 119, 133, 169, 171, 179, 183, 193, 223, 224, 250, 251, 270, 280, 284, 285, 287, 289, 290, 295, 303, 306, 308, 311, 312, 315, 318, 331, 333, 369, 373, 377, 382  
 Society, Scottish, 28, 29, 33, 109, 305, 383, 386, 387  
*Year-Book, The British*, 37, 38
- Meteorological Record, the, 37
- Meteorology, meaning of the term, 1, 2 ; "Dawn of," a lecture by Dr. G. Hellmann, 1, 75 ; relations existing between medicine and, 2 ; a science, 10 ; practical, 26
- Methane in air, 23
- Microbes in air, 24, 425, 426, 430
- Micrococci of pneumonia, 447, 456
- Micro-organisms in air, 24, 425, 426, 430
- Mineral constituents of the atmosphere, 24
- Minimum thermometers, 83, 85-89, 104, 105
- Mist, 190, 193 ; formation of, 193, 207  
 Scotch, 193
- Mistral of the Gulf of Lions, 373
- Mists, cholera blue, 416
- Model illustrating investigation of upper atmosphere, 336, 338
- Moderate climates, 378
- Molecular analysis of air, 13
- Monsoons, Indian, 262, 372
- Monte Rosa, fall of snow on, 250
- Monthly, summary of weather, 34, 36  
*Weather Report, The*, 34, 36, 37  
*Weather Review, United States*, 49, 51, 174, 260, 363, 466  
*Weather Review, Canada*, 71, 72  
*Weather Map, Canada*, 72, 74
- Moon, watery, 163
- Mosquitoes, 364, 365
- Mountain, determination of height of, 150  
 cloud-capped, 202  
 ranges, effect of, on climate, 352, 362, 363
- Munich, International Meteorological Conference, 211, 216, 252, 287
- Musical anemometers, 284
- NASCENT oxygen, 323
- Nature's abhorrence of a vacuum, 115

- Negative, electricity, 296, 302, 305, 306  
 oxygen, 322  
 Negretti and Zambra's maximum thermometer, 84  
 hycograph, 234  
 improved Robinson's anemometer, 275, 276  
 storm rain-gauge, 228  
 Neon, 22, 347, 348  
 Nephometer, spherical mirror, Besson's, 218, 219  
 Nephoscope, 213  
 reflecting, 213, 214  
 direct-vision, 213, 214  
 Fineman's, 213, 214  
 Besson's comb, 214, 215; zenith, 217, 218  
 methods of stating the results of observations by, 215  
 Neutral point, in barometer scale, 144  
 in cloud-slopes, 210  
 Névé, 370  
 Newfoundland fogs, 202  
 Niederschläge, 19  
 Nimbus, 206, 207, 208, 210, 212; different applications of the term, 210, 211  
 Nitric acid in air, 19, 23  
 Nitrogen in air, 19-21  
 Non-periodic barometric fluctuations, 151, 159, 160  
 Normal climatological stations, 28, 30, 42, 43, 94, 107, 134, 147, 238, 382, 403  
 instruments required for, 42, 43  
 Nortés (Northers) of the Gulf of Mexico, 373  
 North-east trade winds, 159
- OBSERVATIONS, meteorological, 26, 27; synchronous, 114, 119, 143, 183  
 barometer, 139  
 cloud, 211  
 nephoscope, 215  
 phenological, 26, 33  
 rainfall, 223, 224
- Observatories, self-recording, 28; normal climatological, 28, 30, 42, 43, 94, 107, 134, 147, 238, 382, 403; auxiliary climatological, 29
- Observatory, Kew, 28, 37, 43, 82, 83, 101, 147, 276, 285, 300, 399  
 Toronto, 69, 74
- Observatory, Greenwich, 28, 93, 300  
 Fernley, Southport, 33, 34  
 Glossop, 306  
 Occasional cold winds, 372  
 warm winds, 372  
 Ocean currents, affecting climate, 100, 352, 358-361  
 warm, 359; cold, 360, 361  
 influence of, on climate, 100, 352, 356, 384  
 October mean temperature, 390  
 Office, Meteorological, London, 7, 28, 29, 30, 33, 37, 38, 40, 109, 128, 129, 148, 149, 150, 209, 225, 238, 266, 327, 348, 383, 388, 394  
 Officers of Health, Medical, 42  
 Ohm, 306  
 Opacity, 18  
 Open-scale barometer, Bartrum's, 131, 132; Barrett's, 138  
 Ordinary thermometers, 82, 83  
 Ordnance Survey, Datum, 148  
 Office, Phoenix Park, 404, 407, 415  
 Organic matter in the air, tests for, 24, 25  
 Osler's anemometer, 271, 287  
 Oxshott, anemometer comparisons at, 271  
 Oxygen, liquid, 14; in air, 19-21; allotropic, 321; negative, 322; positive, 322; nascent, 323; active, 323  
 Ozone, 22, 321; theories as to its nature, 321, 322, 323; properties of, 323, 324; influence on disease, 323, 324; tests for, 324; and cholera, 415  
 Ozonides, 322
- PALLIUM, 207  
 Pampéro of Brazil, 373, 374  
 Pandemic waves, 416  
 Parachute, principle of the, 13  
 Parallax, errors of, in barometer readings, 141; in rainfall readings, 239  
 Paratonnerre, 317  
 Paris, cholera in, 413, 414; International Meteorological Committee, 252  
 Peaty soils, influence of, on health, 364; on climate, 401  
 Pebble beds and climate, 400  
 Peltier's electrometer, 301

- Pendulum anemometers, 270  
 Percolation and rainfall, 171, 172  
   evaporation and condensation, 171, 172  
 Perihelion, 99  
 Periodic, barometric fluctuations, 151  
   thunderstorms, 209, 304; winds, 372, 373  
 Periodicity of temperature, 408; of rainfall, 408; of atmospheric pressure, 408  
 Permanent winds, 372  
 Peruvian current, 361  
 Petersburg, cholera in St., 413, 415  
 Phenological observations, 26, 33  
 Phillips's maximum thermometer, 83, 93  
 Phoenix Park Ordnance Survey Office, 404, 407, 415  
 Photogrameters, 216  
 Photographic thermograph, 92, 93  
   barograph, 128  
   electrometer, 300  
   sunshine recorder, 109, 111  
 Photographs of thunder-clouds, 211  
 Phthisis and subsoil drainage, 364  
 Physical cause of rain, 242  
 Physicians and meteorological information, 391  
 Pickering's evaporimeter, 170  
 Piesmic barometer, 134, 135  
 Pitot's tube, 273  
 Pneumonia, 446; its claims to rank as a specific fever, 456  
 Pneumonic fever, seasonal prevalence of, 446  
   in Dublin, 446, 447  
 Pocky-cloud, 209  
 Poison of diarrhoeal diseases, 425  
 Pole-star, position of the, 268  
 Portable electrometer, Thomson's, 299, 300  
 Positive electricity, 296, 302, 306  
   oxygen, 322  
 Potential, electrical, 296, 298, 311; difference of, 298  
 Practical meteorology, 26  
 Practice forecasts, 59  
 Precipitation, 220, 369  
 Pressure, atmospheric, 17, 114  
   plate anemometer, 271  
   on a fluid anemometer, 273  
 Prevailing winds in relation to climate, 352, 372  
   classification of, 372  
*Protococcus nivalis*, 249  
 Proximity of mountain ranges, 362  
 Psychrometer, 181; ventilated, 185  
 Public Health, Diploma in, 3  
   influence of temperature of the soil on, 106  
   meteorological information bearing on, 391  
 Publications, Division of the United States Weather Bureau, 50, 51  
 "Pumping" in a barometer, 124  
 Pyrheliometer, of Pouillet, 98, 102  
   Angström's electric compensation actinometer and, 102  
 Pyrtton Hill Upper Air Investigation Station, 32, 333, 334, 349  
 Pythogenic pneumonia, 446, 447  
 QUADRANT electrometer, Thomson's, 299-300  
 "Quicksilver, Cylinder of," 119  
 Quito, climate of, 353  
 RADIANT heat, 17, 18, 97  
 Radiation fog, 200  
   of heat, 96-98; terrestrial, 98-100, 102, 104, 105; solar, 98, 99, 101-104, 109  
   thermometers, 82, 93, 101-105  
 "Radiation weather," 162  
 Radio-Integrator, the Wilson, 104  
 Rain, 166, 190; its chief physical cause, 242; atmospheric electricity in production of, 243-246; its distribution, 249, 260-263  
   cloud, 206, 210  
   coloured, 247-249, 264  
   frozen, 192, 254  
   inch of, meaning of term, 263, 264  
   prognosis of, by means of clouds, 207  
   weight and bulk of, 263  
 Rain day, definition of a, 239, 369  
 Rain-drops, size of, 241, 242  
 Rainfall, 42, 67, 221, 223; and disease, 410; weighing the, 224; measurement of, 238, 239  
   *British*, 33, 37, 170, 239, 261, 395  
   and diarrhoea, 422  
   how affected by altitude, 239, 240, 241  
   in relation to climate, 261, 262, 352, 369  
   mean annual of the world, 221  
   land, 222  
   continental and ocean, 223  
   observations, 33, 223, 224, 395



- Rainfall, of the British Islands, 261, 395  
 periodicity of, 408  
 tables prepared by Mr. G. J. Symons, 396  
 torrential, 369
- Rain-gauges, history of, 223-225 ;  
 diameters of, 225 ; best form of, 225 ; varieties of, 225-238 ;  
 snow-melting, 253  
 exposure of, 238
- Ramified lightning, 309
- Rarefaction of air at great altitudes, 16
- Rauh frost, 191
- Réaumur thermometer scale, 77-80
- Recorders, sunshine, 109-113
- Records Division of the United States Weather Bureau, 49, 50  
 "Red rain," 249
- Red snow, 249 ; its cause, 249
- Registering, rain-gauges, 228-237  
 thermometers, 83
- Registration of disease, 455
- Regnault's law, 15-16  
 direct hygrometer, 176, 177
- Regular barometric variations, 151
- Relative humidity, 181, 184, 199  
 mode of determining, 184
- Replenisher, electrical, 300
- Report, The Daily Weather*, 31, 32, 34, 38  
*The Weekly Weather*, 34, 35  
*The Monthly Weather*, 34, 36, 37
- Report on atmospheric electricity, 296
- Reporting Stations, British Telegraphic, 29, 30 ; United States, 52
- Reports, daily weather, 31, 32, 34, 35 ; weekly weather, 34, 35
- Repulsion, capillary, 140 ; electrical, 295
- Return shock in thunderstorms, 310, 311
- Review, United States Monthly Weather*, 49, 51, 67, 174, 260, 363, 466  
*Canadian Monthly Weather*, 71, 72
- Ribbon lightning, 309
- Richard's anémo - cinégraphie, 285 ; actinometer, 102 ; self-recording rain-gauge, 233 ; brontometer, 320 ; statoscope, 320, 321
- Rime, 191
- Rio Janeiro, periodic thunderstorms at, 305
- River, and Flood Section of the United States Weather Bureau, 53, 60, 61  
 and flood work in United States Weather Bureau, 60, 61  
 fog, 200  
 "Roaring Forties," 266
- Robinson's cup anemometer, 271, 274-276, 287, 289
- Roll-cumulus, 209
- Rome, International Meteorological Committee, 91  
 International Meteorological Conference, 225
- Röntgen Rays, 244
- Rosée, 191
- Rotation of earth on its axis, 4, 11, 12, 151
- Royal Meteorological Society, 28, 29, 33, 37, 89, 92, 101, 109, 118, 119, 133, 169, 171, 179, 183, 193, 223, 224, 250, 251, 270, 280, 284, 285, 287, 289, 290, 295, 303, 306, 308, 311, 312, 315, 318, 331, 333, 369, 373, 377, 382  
 Observatory, Greenwich, 28, 93, 119, 300
- Rutherford's spirit minimum thermometer, 85, 86, 104
- SALT, common, in atmosphere, 24, 198  
 dust, 197
- Sands, their influence on climate, 400
- Sandstones, 400
- Sanitary Science, Diploma in, 3
- Saturation, 167 ; percentage degree of, 178-181, 184
- de Saussure's hair hygrometer, 178
- Scale, Beaufort, of Wind Force, 32, 36, 38, 39, 40, 266 ; of Weather, 32  
 barometer, 143 ; adjustment of, Wallis's, 123, 124  
 for Amount of Cloud, 211  
 of Sea Disturbance, 41, 42  
 thermometer, 76-80, 82  
 vernier, 140-143  
 weather, 41
- Scarlatina, seasonal prevalence of, 434, 442, 443
- Schists, 400, 402  
 "Schneefresser," 354

- "Schneegestöber," 252  
 "Schneetreiben," 252  
 Scientific work of the United States  
     Weather Bureau, 66  
 Scilly Isles, climate of, 356, 388, 389,  
     390  
 Scirocco of North Africa and Sicily,  
     374  
 Scotch mist, 193  
 Scotland, subsoil temperature in,  
     365; temperature of, 386-390;  
     distribution of rainfall in, 261,  
     396-399; soils in, 400  
 Scottish Meteorological Society, 28,  
     29, 33, 109, 305, 383, 386, 387  
     *Journal of the*, 37, 383, 387  
 Screen, thermometer wall, 91  
 Scud-cloud, 207, 211  
 Sea breezes and land breezes, 208, 209  
 Sea disturbance, Scale of, 41, 42  
 Sea-fogs, 193, 202  
 Sea-Forecast Districts (British  
     Isles), 383  
 Sea-level, reduction of barometer  
     readings to, 148; of tempera-  
     ture to, 390  
 Sea-temperature stations round  
     British Islands, 383  
 Sea temperatures round British  
     Islands, 356, 383; in the Atlan-  
     tic, 360, 361  
 Sea-water, electrical state of, 302  
     freezing-point of, 357  
     maximal density of, 357  
 Searchlight signals in meteorology, 65  
 Season, influence of, on disease, 409;  
     on rainfall, 240  
 Seasonal distribution of rainfall,  
     260, 262; thunderstorms, 305,  
     306; disease, 409  
 Secondary barometric depression,  
     161, 304  
 Self-recording observatories, 28  
     anemometer, Casella's, 269, 289  
     barometers, 126; Dines's, 135  
     electrometer, 300  
     evaporation-gauge, Richard's, 169  
     rain-gauges, 228-237  
     thermometers, 82, 92, 93  
 Serein, 191  
 Shales, 400, 401  
 Sheet-cloud, 205, 206, 207  
     lightning, 308, 310  
 Shiga bacillus, 425, 426  
 Shock, return, in thunderstorms,  
     310, 311  
 Shower-cloud, 206, 210  
 "Showers of blood, 247  
     of sulphur," 247, 248  
     remarkable, 248  
 Siberia, excessive climate of, 157,  
     354, 355, 367, 378  
 Signal-Officer, United States Chief,  
     45, 46, 52  
 Signals, storm and cautionary, 62, 64  
     cannon-firing, 64  
     flags, 63, 64  
     railway train, 64  
     searchlight, 65  
     telephone, 65  
     whistle, 64  
 Silver thaw, 191, 192, 254  
 Simoom of Arabia, Kutchee, and  
     Upper Scinde, 375  
 Siphon barometer, 123, 125, 144  
 Six's thermometer, 86, 87  
 Sky, mackerel, 206, 207  
 Slates, 400, 402  
 Sleet, 249, 253; definition of, 253  
 Sling thermometer, 92  
 Slopes, cloud, in cumulus, 209, 210  
 Smallpox, seasonal prevalence of,  
     437; in Dublin, 439; in Sweden,  
     439; in London, 437, 438, 440  
 Smoke-fog, dry, 193, 201; wet, 200,  
     201; as a deodoriser, disinfec-  
     tor, and antiseptic, 201  
 Snow, 190, 249; its properties, 249;  
     its measurement, 252, 253; fall  
     of, on Monte Rosa, 250  
     red, 249; green, 249; dust, 252  
 Snow-covering, 105, 249, 369  
     effects of, on climate, 369, 370  
 Snow-crystals, 249, 250, 251  
 "Snow-devourer," the, 354  
 Snow and drift warnings by Cana-  
     dian Meteorological Service, 73,  
     74  
 Snowdon rain-gauge, 172, 226  
 Snowfall, limit of, 369  
 Snowflakes, 249  
 Snow forecasts, 73  
 Snow-line, mountain, 353  
 Snow-melting, mechanism of, 370,  
     371  
 Snow-rollers, 251, 252  
 Society, Royal Meteorological, 28,  
     29, 33, 37, 89, 92, 101, 109, 118,  
     119, 133, 169, 171, 179, 183,  
     193, 223, 224, 250, 251, 270,  
     280, 284, 285, 287, 289, 290,  
     295, 303, 306, 308, 311, 312,  
     315, 318, 331, 333, 369, 373,  
     377, 382

- Society, Scottish Meteorological, 28,  
29, 33, 109, 305, 383, 386, 387
- Sodium chloride in air, 24, 198
- Soft hail, 258
- Soil, temperature of the, 105, 364,  
365; its relation to health, 106-  
109, 416, 417; its relation to  
climate, 352, 363-365, 399-402  
a cause of diarrhoeal diseases, 422,  
423
- Solano of Spain, 374
- Solar halos, 163, 206, 207  
intensity apparatus, Padre  
Secchi's, 102  
radiation, 98, 99, 101, 109; how  
measured, 101; thermometers,  
101-104
- Solstice, meaning of term, 12
- South-east Trade Winds, 159
- Southport International Meteorological  
Committee, 287  
Observatory, 33, 34
- Specific gravity of mercury, 116; of  
water, 116; of ice, 258, 259  
gravity, heights of columns of  
liquids or gases inversely pro-  
portional to their, 115, 117  
heat defined, 356  
heat of mercury, 86; alcohol, 86;  
water, 100
- Spectre of the Brocken, 203
- Spectroscopy in meteorology, 67
- Spirit minimum thermometer, 85, 86
- Spring fog, 202
- Springs, influence of forests on, 366,  
367
- Stand, thermometer, 43, 84, 89-92
- Standard, thermometers, 42, 82  
barometer, 123  
temperature in barometric obser-  
vations, 147
- State Medicine, Diploma in, 3
- State Weather Service Division of  
United States Weather Bureau,  
49, 64
- Stations, of the First Order, 28, 128  
Anemograph, 29  
Extra Reporting, 30  
Foreign Reporting, 29  
of United States Weather Bureau,  
52, 54  
Phenological, 33  
Sea-temperature, round British  
Isles, 383  
Second Order, 28, 30, 42, 43, 94,  
107, 134, 147, 238, 382, 403;  
instruments required for, 42, 43
- Stations, Telegraphic Reporting, 29,  
30, 52  
Third Order, 29, 30  
Upper Air Investigation, 32, 327,  
331, 333  
working in connection with the  
Meteorological Office, London,  
30
- Statoscope, Richard's, 320, 321
- Stefan's Law, 341
- St. Elmo's Fire, 312
- St. Petersburg, cholera in, 413, 415  
"Step" anemometer, 275, 276
- Stevenson, thermometer stand, 43,  
84, 89, 90
- Storm of February, 1903, 13, 290,  
291  
rain-gauge, 226  
signals, 62, 64, 67  
warnings, 62, 64, 65, 67, 73, 74
- Storms, classification of, 290  
magnetic, 314, 316
- Straight isobars, 161
- Strato-cumulus cloud, 212
- Stratosphere, 336, 343
- Stratus clouds, 205, 207, 208, 212
- Stream lightning, 309
- Subsidiary barometric depression,  
161, 304
- Subsoil water, influence of, on  
health, 364, 416, 417, 431, 432  
temperature (in Trinity College,  
Dublin), 406; influence of, on  
health, 106-109, 416, 417, 422,  
423, 434
- Suction anemometers, 278
- Sulphurous acid in air, 19, 23
- Summer, diarrhoea and subsoil tem-  
perature, 106-109, 417  
climate of British Islands, 379  
distribution of atmospheric pres-  
sure, 10, 156; of thunderstorms,  
305; of disease, 417  
rains on the Continent of Europe,  
262  
haze, 203; lightning, 308, 310  
sea-temperatures, 385
- Sun, watery, 163; southing of the,  
268  
"Sunless day," 113
- Sunshine, duration of bright, 109;  
in Trinity College, Dublin, 405;  
measurement of, 109-113  
recorders, 109-113
- Sun-spots, and weather, 314  
and magnetic storms, 314
- Supersaturated air, 195-197

- Surface, configuration of, effect on climate caused by, 357  
trajectories of moving air, 291, 292
- Sweden, smallpox in, 439
- Symons's brontometer, 320, 321
- Sympiesometer, 137
- Synchronous observations, 114, 119, 143, 183
- Synoptic Weather Charts, 27, 35, 160
- TELEGRAPH, section of the Forecast Division of the United States Weather Bureau, 49; lines in United States, 49
- Telegraphic Reporting Stations, 29, 30, 52; in Canada, 70, 71, 72  
transmission of barometric indications, 130  
Weather Code, United States, 54, 55
- Telegraphy, application of, to weather study, 26, 27, 49, 70, 72-74
- Telephone in meteorology, 65  
"Telluric influences" in spread of disease, 416
- Temperature, accumulated, 36, 351  
air and its measurement, 42, 75, 81  
and diarrhœa, 107, 420, 421; and enteric fever, 431  
anemometer, 277  
base, 35  
correction for, in reading the barometer, 122, 143, 147, 148  
earth, 105, 365, 416  
effect of elevation on, 99, 100, 352; effect of forests on, 367, 368  
"inversion" of, 100, 331  
lowest mean monthly, recorded, 355  
mean, 93-95; average mean, 94; and disease, 410  
of sea round British Islands, 356, 383  
periodicity of, 408
- Tempest of February, 1903, 13, 290, 291
- Tension of, aqueous vapour, 151, 152, 165, 175, 181, 186  
electricity, 296, 298
- Terling, enteric fever at, 432
- Terrestrial radiation, 98-100; how measured, 102, 104, 105
- Tests for ozone, 323, 324
- Thaw, silver, 191, 192, 254  
cirrus cloud a sign of, 206
- Theory of the winds, 4, 5, 6
- Thermal unit, 359
- Thermograms, 94
- Thermographs, 92, 93
- Thermometer, 75; meaning of word, 75; construction of a, 80-81; description of a, 80  
attached, 139  
black-bulb, *in vacuo*, 101  
bright-bulb, *in vacuo*, 101  
dry-bulb, 148, 181  
earth, 96, 105, 106  
hypsometer, 137, 138  
maximum, 83-85  
minimum, 83, 85-89  
ordinary, 82, 83  
radiation, 82, 93, 101-105  
registering, 83, 86, 87  
scales, 76-80, 82  
self-recording, 82, 92, 93  
solar radiation maximum, 101-104  
stand, 43, 84, 89-92  
standard, 82  
wet-bulb, 181; management of, 184, 185  
Bourdon tube, 327; bimetallic, 328
- Thermomètre fronde*, 92
- Thermometric gradient, 380
- Thermoscope, Philo's, 75, 76
- Thomson's water-dropping collector, 298; electrometers, 299
- Thunder, 208, 211, 255, 308; what it is, 308; its relation to hail, 255; to electricity, 296
- Thunderbolts, non-existent, 310, 311
- Thunderclouds, characteristics of, 211
- Thunderstorm, depression, 255, 303, 304  
at Mere, Wilts, May 13, 1906, 309, 310  
Committee of the Royal Meteorological Society, 303, 308
- Thunderstorms, periodic, 209, 304; heat, 302, 303; cyclonic, 302, 313; Mohn's classification of, 302; analysis of, 303; occurrence of, 369
- Time, Greenwich, conversion of, to local, 268
- Tormentos of the Argentine Republic, 373



- Tornadoes, 255-257, 375  
 Toronto Meteorological Register, 71, 72  
 Torrential rainfalls, 369  
 Torricellian column, 118, 119  
   experiment, 115, 117, 118  
   vacuum, 115, 122, 125  
 Torsion anemometer, 271; balance electrometer, Coulomb's, 298, 299  
 "Tourmente de neige," 252  
 Town fog, 200-202  
 Trade Winds, 159, 372  
 Trajectories of moving air, 291, 292  
 Tramontana of the Adriatic, 373  
 Transmission of barometric indications by electricity, 130  
 Transparency of the atmosphere, 17, 199  
 Trappes Observatory, 327, 346  
 Trees and lightning, 311  
 Trinity College, Dublin, enteric fever in, 432, 433  
   Normal Climatological Station, 107, 403  
   tornado in, 257  
 Tropics, meaning of term, 12; diurnal variation of barometer in the, 151  
 Troposphere, 336, 343  
 Tube anemometer, 289  
 Twilight, 16, 17  
 Typhoid fever, seasonal prevalence of, 431, 434  
 Typhoons, 162  
 Typhus fever, seasonal prevalence of, 435-437
- UNDERGROUND water and health, 364, 416, 417, 431, 432  
   thermometer, 96, 97, 105  
 United States Weather Bureau, 44-68, 70  
   *Monthly Weather Review*, 49, 51, 67, 174, 260, 363, 466  
   its scientific work, 66; its stations, 52, 54  
   service created, 45; its cost, 48; its publications, 50, 51  
 Units, absolute or metric, in upper-air investigation, 348, 349  
 Universal Sunshine Recorder, 109, 111  
 "Upbank thaw," 100  
 Upper Air, British Stations for Investigation of, 32, 333  
   Foreign Stations for Investigation of, 325, 327, 331  
 Upper Atmosphere, Investigation of the, 325-349  
   history of, 325-328  
   instruments for use in, 185, 328-330  
   absolute or metric units in, 348, 349  
   absorption of solar radiation in, 341  
   composition of air in, 347, 348  
 Upper, clouds, 206; atmosphere. electrical state of, 306  
 Upsala International Meteorological Committee, 212, 213  
 Utrecht International Meteorological Congress, 38, 42
- VACUUM, Torricellian, 115, 122, 125  
 Valleys, temperature in, 358  
 Vane, 267  
 Vapour, aqueous, in the air, 19, 25, 165, 166, 354; tension of, 151, 152, 165, 175, 181, 186; atmosphere of, 165, 175, 190, 205, 220; amount of, required for saturation, 181; where most abundant, 186  
 Variable winds, 372  
 Vartry Water Supply, Dublin, 432  
 Veer, meaning of, 163  
 Vegetation in relation to climate, 351, 352, 365-369  
 Velocity, of wind, 7, 266; in storm of February, 1903, 291  
   anemometers, 274  
 Venice, hailstorm in, 257, 258  
 Ventilated psychrometer, 185  
 Verglas, 192, 254  
 Verification Certificate, Kew Observatory, 82  
 Vernier in the barometer, 140-143; method of reading it, 141-143  
 V-shaped depression, 161; thunderstorms in, 162  
 Vibrations of light, 17  
 Vienna International Meteorological Conference, 8, 181, 225, 268, 270, 287, 296; Committee, 38, 91, 296  
 Volcanic dust, 197  
 Volta's collector, 297  
 Volts, 300, 311; meaning of, 300  
 Volumetric analyses of air, 19, 20
- WALES, distribution of rainfall in, 396, 397  
 Wall screen, thermometer, 91

- Water, boiling-point of, 76-79, 138, 194  
 dust, 205  
 free surfaces of, 167, 193, 194  
 freezing-point of, 76, 79, 80, 81, 194  
 influence of, on climate, 352, 356  
 specific heat of, 100; specific gravity of, 116  
 subsoil, influence of, on health, 364, 416, 417, 431, 432  
 underground, 364, 416, 417, 431, 432
- Watery moon, 163, 207  
 sun, 163, 207  
 vapour in the air, 19, 25, 165, 166, 354; tension of, 152, 165, 175, 181, 186; where most abundant, 186
- Wave-lengths of light, 17; of heat, 17, 18
- Weather, 26; Merle's Journal of the, 26; telegraphy and, 27; bureaux, 27; reports, daily and weekly, 31, 32, 34, 35; scale of, 41; bureau of United States, 44-68, 70; service, United States, 45; its cost, 48; Service, Canadian, 69-74; influence on disease, 409  
 and health, 2  
 anticyclonic, in winter, 157, 158, 164; in summer, 164  
 radiation, 162
- Weathercock, 267
- Weather-crop bulletin, United States, 49
- "Weather-glass," 119, 126
- Weather maps, 27, 31, 32, 45, 51, 55, 56, 57, 67, 70, 71, 72, 73, 160
- Weather Report, The Daily*, 31, 32, 34, 38, 40, 41, 42
- Weather Report, The Monthly*, 34, 36, 37
- Weather Review, Monthly, United States*, 49, 51, 67, 174, 260, 363, 466
- Weather telegrams, 38
- Wedge of high pressure, 161
- Weekly Weather Report*, 34, 35, 37
- Weight, of air, 13, 181; of hailstones, 258, 259; of rain, 263  
 of vapour in a cubic foot of air, 181
- Wells's *Essay on Dew*, 190
- Werchojansk, low temperature at, 355
- West India hurricanes, 162
- Wet-bulb thermometer, 181; management of, 184, 185
- Wet fog, 193
- Wetterleuchten*, 310
- Wheel-barometer, 119, 126
- Whipple-Casella "Universal" Sunshine Recorder, 109, 110, 111
- Whirlwind, 375
- Whistle-signals in United States, 63, 64
- Wilson Radio-integrator, 104
- Wind, definition of, 4, 265; direction of, how determined, 7, 267; velocity or force of, 7; in storm of February, 1903, 291; how generated, 15, 16; relation between the pressure gradient and velocity of, 9; direction of, 38, 287; force, Beaufort scale of, 32, 36, 38, 39, 40, 266; true direction of, 38, 41; veering of, 163; hauling of, 163; backing of, 163
- Windrose, 38, 268; how constructed, 268
- Winds, Trade, 159, 372; prevailing, and climate, 352, 372; permanent, 372; periodic, 372; variable, 372; uses of, 372; influence on climate, 372; occasional cold, 372, 373, 374; occasional warm, 372, 374, 375
- Winter, distribution of atmospheric pressure, 10, 157, 158; of thunderstorms, 305; of disease, 410-412  
 climate of British Islands, 379, 380  
 fog, 165, 202  
 sea-temperatures, 384
- Wool-pack cloud, 205
- Xenon, 22
- X-Rays, 244
- YAKUTSK, extreme temperatures at, 354, 355
- Year-Book, The Meteorological*, 37
- Yeates's electric self-registering rain-gauge, 229
- ZERO, displacement of, 81, 82
- Zigzag lightning, 308
- Zones, climatic, 350

## INDEX OF PROPER NAMES

- ABBE, Professor Cleveland, 44, 45, 66  
 Abbott, 341  
 Abercromby, Hon. Ralph, 7, 154,  
     161, 162, 211, 301, 309  
 Adie, P., 124, 137, 147, 274  
 Aitken, John, 191, 193-200, 201  
 Anaximander of Ionia, 4  
 Andrand, 323  
 Andrews, Dr., 321, 322  
 Angot, Dr. A., 262  
 Ångström, 102  
 Apjohn, Professor James, 182, 432  
 Appleby, W. E., 247  
 Arago, François, 92, 304, 310  
 Archibald, E. Douglas, 326  
 Aretæus, 409  
 Aristotle, 1, 409  
 Asclepiades, 409  
 Assmann, Professor R., 185, 329,  
     331, 344  
 August, 182  
 Austen, Ernest E., 427, 430  
  
 BABINGTON, 168  
 Baker, T. W., 147  
 Ball, Sir Robert S., 14  
 Ballard, Dr. Edward, 3, 106, 417,  
     420-424, 439-441, 445  
 Barrett, W. F., 138  
 Bartholomew, J. G., 221  
 Bartrum, 131  
 Bassett, 425  
 Bayendell, Joseph, 34, 172  
 Bayard, Francis Campbell, 153, 156,  
     382  
 Beaudoux, 279  
 Beaufort, Admiral Sir F., 32, 36, 38,  
     39, 40, 266  
 Beaufoy, 271  
 Beckley, 285  
 Becquerel, 244, 302  
 Bentley, W. A., 241, 242, 251, 466  
 Benzenberg, 279  
 Berghaus, Dr. Heinrich, 221  
 Bernacchi, L. C., 371  
 Bernoulli, 278  
 Berson, Professor, 345  
 Besançon, 328  
 Besant, 133  
 Besson, Louis, 214, 217, 218  
 Best, Captain, 361  
 Bezold, Von, 343  
 Bigelow, Professor Frank H., 67,  
     174, 260  
 Binnie, Sir Alexander, 225  
 Boate, Dr. Arnold, 406  
 Boate, Dr. Gerard, 406  
 Boeddicker, Dr. Otto, 248  
 Bonacina, L. C. W., 247  
 Bort, L. Teisserenc de, 213, 327, 331,  
     336, 346-348  
 Bouguer, 271  
 Bourdon, 133, 278, 327, 328  
 Bowditch, Dr., 364  
 Boyle, Hon. Robert, 14, 16, 119  
 Black, W. S., 221  
 Black, W. T., 258  
 Blanford, Henry F., 121, 220  
 Blyth, A. Wynter, 22, 24  
 Brewster, Sir David, 277  
 Briggs, Lynam T., 173  
 Brockway, Dr. Fred. J., 122  
 Brodie, Sir B. C., 322  
 Brodie, F. J., 290  
 Broussais, 457  
 Browett, Charles, 251  
 Brown, Horace T., 23  
 Bryant, W. W., 313  
 Buchan, Dr. Alexander, 98, 99, 156,  
     159, 184, 221, 248, 305, 362,  
     365, 379, 380, 383-387, 394-  
     399, 418, 420, 434, 436, 437,  
     439, 442, 445, 466  
 Buchanan, Sir George, 364, 432

- Buckingham, Edgar, 173  
 Buhl, Professor, 3, 432  
 Bunsen, 19, 24  
 Burns, Right Hon. John, 430  
 Buys Ballot, 4, 6, 9, 157, 158, 159,  
 265, 378  
  
 CACCIATORE, 279  
 Cæsar, 312  
 Caldeleugh, 305  
 Calkins, Professor R. D., 466  
 Campbell, 244  
 Campbell, John F., 109  
 Capper, Colonel J. E., 327  
 Carnelley, Professor, 194  
 Carpmael, Charles, M.A., 70  
 Casella, Louis Marino, 280, 281, 289  
 Casella, Louis P., 85, 87, 102, 104,  
 105, 109, 110, 137, 138, 229,  
 269, 277  
 Castelli, B., 223  
 Cator, 271  
 Cavendish, Lord Charles, 86  
 Celsius, 77-80  
 Celsius, 3, 409  
 Chambers, Frederick, 154  
 Chanut, 118  
 Charles, 15, 16  
 Chaucer, 267  
 Child, Walter, 275, 276  
 Chree, Dr. Charles, 316  
 Churchill, John, 205  
 Cicero, 1  
 Clayton, H. H., 327  
 Clouston, Rev. Charles, 466  
 Cole, Dr. Frank N., 418  
 Colladon, Professor, 313  
 Collinson, Peter, 294  
 Columbel, Rev. Augustus M., 154  
 Copeman, Dr. S. Monckton, 430  
 Cosgrave, Henry A., 203, 258  
 Cotter, J. R., 187, 246  
 Coulier, M., 243  
 Coulomb, 298  
 Coxwell, 326  
 Craveri, 279  
 Creighton, Dr. Charles, 447  
 Croll, 359, 360  
 Crosley, 229  
 Crova, A., 187, 188  
 Curie, M. and Mme., 244  
 Curtis, J. A., 33  
 Curtis, R. H., 33, 290, 326, 327  
  
 DALBERG, 270  
 Dalton, John, 15  
 Dancer, J. B., 24  
  
 Daniell, Professor, 175, 176  
 Dante, 355  
 Davis, A. S., 134  
 Debierue, 244  
 de Bort, L. Teisserenc, 213, 327,  
 331, 336, 346-348  
 Dechevrens, 280  
 Delamanon, 284  
 Descartes, 118  
 Dewar, Professor, 14  
 Dines, George, 175, 177, 178, 192,  
 220, 239, 271, 272, 275  
 Dines, W. H., 32, 135, 284, 287, 289,  
 327-331, 333, 334, 349  
 Diversus, Petrus Salius, 412  
 Dove, 151, 152, 255  
 Dowling, Professor, 432  
 Dowson, E. T., 154  
 Dunning, 412  
 Duval, 425  
  
 EBERTH, 456  
 Edgeworth, Richard Lovell, 274  
 Egnell, 344  
 Ekholm, M., 185  
 Elias, Dr., 345  
 Eliot, Sir John, 220, 263  
 Ellis, William, 119, 129, 133, 154  
 Elsholtz, 248  
 Erman, Professor Adolf, 6, 301  
 Evans, Sir F., 361  
 Everett, Professor J. D., 296  
  
 FAHRENHEIT, 15, 76-78, 80, 351  
 Fautrat, M., 366  
 Faye, Professor, 413, 415  
 Fenyi, 341  
 Fergusson, 327, 328, 329  
 Ferrel, Professor William, 66, 260  
 Field, Rogers, 137  
 Fineman, C. G., 213, 216  
 Fisher, Rev. George, 325  
 FitzRoy, Admiral Robert, 27, 45,  
 125  
 Flammarion, 326  
 Flexner, 425  
 Flint, Austin, 431  
 Forbes, Principal, 106  
 Forster, Captain, J. V., 360  
 Fortin, 122-123, 139, 143, 144  
 Foster, Henry, 265  
 Foster, Rev. W., 274  
 Fowle, 341  
 Fox, Dr. Cornelius B., 19, 324  
 Fränkel, 456  
 Frankland, Professor E., 22, 201



- Franklin, Benjamin, 44, 294, 317, 325  
 Friedländer, Dr. C., 447, 456  
 Fuller, M. L., 466
- GALILEO, Galilei, 114, 115, 223  
 Galton, Francis, 271  
 Gay-Lussac, Louis Joseph, 15, 125, 205  
 Gardien, H., 306  
 Glaisher, James, 133, 183, 184, 250, 324, 326, 460  
 Glassford, Lieutenant W. A., 392  
 Glover, Dr. V. J., 427, 429, 430  
 Goddard, 279  
 Godefroy, 192  
 Gold, Ernest, 8, 325, 327, 336-343, 345  
 Graham, 23  
 Gravelius, Professor H., 367  
 Greely, General A. W., 68, 355  
 Grey, Admiral Sir F. W., 466  
 Griffith, Rev. C. H., 225  
 Grimshaw, T. W., late Registrar-General for Ireland, 28, 418, 419, 431, 434, 435, 437, 446, 448  
 Guericke, Otto von, 17
- HAGEMANN, G. A., 278, 279, 289  
 Halliwell, 172, 235  
 Hancock, Dr. Thomas, 412  
 Hann, Dr. J., 99, 242, 260, 375  
 Harding, Charles, 121, 381  
 Harper, Dr. C. R., 373  
 Harrington, Mark W., 46, 391  
 Hart, Dr. Ernest, 416  
 Hart, Samuel, 466  
 Hartnup, 128  
 Harwood, W. A., 325, 327, 329, 336-339, 341-343  
 Haughton, Rev. Samuel, 167, 242, 432  
 Hazen, General William B., 67  
 Heberden, Dr. William, 410  
 Hellmann, Professor Dr. G., 1, 4, 75, 118, 223, 251  
 Helmholtz, Von, 244  
 Hennessy, Professor, 280  
 Henry, Professor, 44  
 Hepworth, Captain, 327  
 Hepworth, M. W. Campbell, C.B., 33  
 Herbertson, Dr. A. J., 221, 222, 223, 262, 387-389  
 Hergesell, H., 328, 329, 344  
 Hermite, 328  
 Hero of Alexandria, 75, 76
- Herschel, Sir John, 98, 100-102, 240, 242, 248, 359  
 Hesiod, 12  
 Hicks, James J., 131  
 Hildebrandsson, H., 211, 213, 347  
 Hill, Professor E. G., 216  
 Hill, Rev. E., 133  
 Hippocrates, 3, 409  
 Hirsch, Dr. August, 107, 409, 412, 417, 423, 447, 448  
 His, 425  
 Holmes, F., 310  
 Homer, 12  
 Hooke, Robert, 119, 126, 224, 270, 284  
 Hope, Dr. Edward W., 424  
 Hopkins, Rev. G. H., 459  
 Horace, 408  
 Houzeau, 22  
 Howard, L. O., 427  
 Howard, Luke, 205, 207, 210, 247  
 Howlett, 270  
 Humboldt, 151, 355, 361  
 Humphreys, Professor W. J., 339,  
 Hunt, 324 [341, 343  
 Hutton, 180
- JACKSON, Dr. Daniel D., 427-429  
 James, Colonel Sir H., 275  
 Jefferson, President Thomas, 44  
 Jelinek, 186, 271  
 Jepsen, 430  
 Jevons, 241  
 Jewell, Dr., 67  
 Joly, J., 130  
 Jordan, James B., 109, 111-113, 117  
 Jordan, T. B., 111  
 Joule, Dr., 360  
 Judd, Professor J. W., 249
- KÄMTZ, L. F., 247  
 Kane, Sir Robert, 401  
 Kelvin, Lord, 13, 298, 299, 300, 301  
 Kettler, 355  
 King, Alfred, 126, 127  
 King, Dr. E. Slade, 456  
 King, Samuel A., 46, 47  
 Kingston, Professor G. T., 70  
 Kircher, Athanasius, 284  
 Klebs, 456  
 Klein, Professor E., 427  
 Koch, 416, 456  
 Köppen, Dr. W., 211, 381  
 Kugler, Rev. Franz Xavier, S.J.,
- LADUREAU, A., 23  
 Lamarck, 205

- Lambert, 287  
 Lamont, Professor von, 168  
 Langley, Professor S. P., 66, 293  
 Lapham, Professor J. A., 45  
 Laplace, 149  
 Latham, Baldwin, 171  
 Laughton, John Knox, 153, 270,  
 274, 283, 359  
 Lawes, Lady, 224  
 Lawson, Inspector-General Robert,  
 153, 156  
 Lemme, Professor, 246  
 Lemonnier, 294  
 Lempfert, R. G. K., 33, 290, 292  
 Lentz, 425  
 Le Roy, 190  
 Leslie, Sir John, 181, 277  
 Leupold, 271, 284  
 Leutmann, 271  
 Leverrier, 27, 45  
 Ley, Captain C. H., 332, 333  
 Ley, Rev. W. Clement, 4, 154  
 Liais, M., 17  
 Liebermeister, 432  
 Lind, 272, 289  
 Lippincott, R. C. Cann, 460  
 Lloyd, Rev. Humphrey, 4, 255-257,  
 432  
 Lodge, Sir Oliver, 316  
 Lomonosow, 274, 279  
 Longfellow, H. W., 202, 211  
 Loomis, Professor, 66, 121, 221, 314  
 Lovibond, Joseph W., 204  
 Lowne, R. M., 277  
  
 MADISON, Bishop, 44  
 Makower, W., 306  
 Mann, Dr. Robert J., 13, 16, 167, 318  
 Mannucci, Signor, 211, 212  
 Manson, Sir Patrick, 365  
 Marcet, Dr. William, 193, 255, 295,  
 315  
 Marniac, 321  
 Mariotte, Edmé, 14, 16, 224  
 Marriott, William, 113, 134, 139,  
 141, 183, 287, 303, 321, 373,  
 374, 377  
 Marsden, E., 306  
 Martini, 425  
 Marum, Van, 321  
 Marvin, Professor C. F., 66, 173, 174,  
 329  
 Mason, 181  
 Mathieu, 366, 367  
 Maury, Commodore, 44  
 Mawley, E., 28  
 McPherson, Dr. J. G., 191  
  
 Meinert, Dr. E., 423, 425  
 Mellish, H., 252, 466  
 Melville, Thomas, 325  
 Mendenhall, Dr. T. C., 66, 67  
 Mêne, M., 21  
 Merle, Rev. William, 26  
 Metcalfe, H. J., 259  
 Meton, 2  
 Michell, Mr. Sloane, 456  
 Mill, Dr. H. R., D.Sc., 33, 37, 104,  
 170, 225, 249, 261  
 Miller, Professor, 23, 24  
 Milton, John, 198, 355  
 Mitchell, Sir Arthur, 3, 373, 418, 420,  
 434, 436, 437, 439, 442, 445  
 Moffat, Dr., 324  
 Mohn, Professor Henry, 302  
 Moore, Arthur Robert, 107  
 Moore, Dr. William D., 431  
 Moore, Maurice Sydney, 407  
 Moore, Thomas, 208  
 Moray, Sir Robert, 270  
 Morgagni, 412  
 Morgan, H. de Riemer, 426  
 Morse, 44  
 Müller, Dr., 311, 315  
 Mund, 345  
 Murchison, Dr. Charles, 431, 435,  
 437  
 Murray, Sir John, 221  
 Murray, 426  
 Myer, General, 45  
  
 NASH, Dr. James T. C., 427  
 Nasmyth, James, 308  
 Negretti, 83, 84, 228, 234, 235, 275  
 Nettie, Dr. John, 251  
 Neumann, Dr., 375  
 Neumayer, 211  
 Newstead, Robert, 427  
 Newton, William B., 179  
 Nollet, Abbé, 271  
 Nordenskiöld, Dr. G., 251  
 Nuttall, Dr. G. H. F., 427, 430  
 Nyrop, 279  
  
 ODLING, 322  
 Orpen, Dr. Thomas H., 406, 407  
 Orr, 426  
 Osler, Professor, 271, 287, 425  
 Overduyn, Professor, 278  
  
 PAINE, Hon. H. E., 45  
 Parke, 425  
 Parkes, Sir Edmund A., 3, 277, 363,  
 364  
 Parmenides, 350

- Parry, Captain Sir Edward, 325  
 Pascal, Blaise, 118  
 Paschen, 341  
 Peltier, 301, 302  
 Pernter, M., 185  
 Perrault, Pierre, 224  
 Perrier, 118  
 Petavel, J. E., 306, 329, 323  
 Petermann, 365  
 Pettenkofer, Professor von, 3, 364,  
     417, 431  
 Phillips, Professor, 83, 102, 278  
 Philo of Byzantium, 75  
 Piche, 173  
 Pickering, 270  
 Pickering, Spencer P., 169, 170  
 Pictet, 190  
 Pim, Greenwood, 203  
 Pitot, 273  
 Plato, 1  
 Pockels, Professor F., 363  
 Poëy, 207  
 Poincaré, Lucien, 243, 245  
 Pouillet, 98, 102  
 Preston, Dr. Thomas, 187, 246  
 Price, James, 171  
 Pring, T. V., 333  
 Ptolemy, Claudius, 350  
 Pujoulx, 271  
  
 QUETELET, 3, 301, 323  
  
 RAMBAUT, Professor, A. A., 459, 460  
 Ramsay, Sir William, 22, 23  
 Rawlinson, Sir Henry, 1  
 Rayleigh, Lord, 22  
 Réaumur, 77-80  
 Redier, Louis, 128  
 Regnault, 15, 16, 19, 175, 176, 182  
 Richard, frères, 102, 169, 219, 233,  
     285-287, 320, 327-329  
 Richmann, Professor, 294  
 Riggenbach, A., 213  
 Risler, 21  
 Rive, Auguste de la, 302, 321  
 Robinson, Rev. T. Romney, 271,  
     274-276, 287, 289  
 Romas, M. de, 294  
 Ronalds, Sir Francis, 128, 271  
 Röntgen, 244  
 Rooke, "Master," 270  
 Ross, Sir James, 371  
 Rosse, Earl of, 248  
 Rotch, A. Lawrence, 325, 327, 331, 346  
 Rouse, 13  
 Rowland, Professor, 67  
 Royds, Lieutenant C. W. R., 371  
  
 Rue, De la, 169, 311, 315  
 Rundell, W. W., 154  
 Rundle, Dr. Claude, 426  
 Rusk, 133  
 Russell, Hon. Rollo, 259  
 Russell, R., 373  
 Russell, Spencer C., 312, 313  
 Rutherford, Professor, 85, 104, 244,  
     245  
 Rutty, Dr. Thomas, 406, 407  
 Ryssselberghe, Professor F. van, 93,  
     129  
  
 SABINE, 151  
 Salleron, 129  
 Sanctorio, 76  
 Sandwith, F. M., 375  
 Saussure, de, 178, 294, 295, 301  
 Schaeffer, George C., jr., 47  
 Schmidt, 244, 270  
 Schönbein, 321, 322  
 Schreiber, P., 260  
 Schübler, 301, 363  
 Schumacher, 148  
 Scoresby, 18  
 Scott, Dr. R. H., 6, 18, 25, 77, 80,  
     93, 98, 128, 139, 149, 166, 167,  
     177, 183, 186, 192, 205, 207,  
     210, 238, 242, 250, 255, 262,  
     268, 287, 296, 298, 301, 306,  
     310-312, 314, 317, 320, 321,  
     350, 351, 355, 361, 362, 373,  
     380, 381, 394  
 Secchi, Padre, 102  
 Seeley, Professor H. G., 399-402  
 Semple, 407  
 Shakespeare, 200  
 Shaw, Dr. W. N., 7, 9, 33, 107, 251,  
     290, 291, 292, 336, 340, 343, 349  
 Shiga, 425, 426  
 Sidebottom, James, 253  
 Siemens, Dr. C. William, 98  
 Six, James, 86, 190  
 Smith, Angus, 19, 20, 22  
 Socrates, 1  
 Soddy, Professor, 244  
 Soret, 323  
 Southall, T., 101  
 Stark, 3  
 Steel, Thomas, 247  
 Stefan, 341  
 Stevenson, Robert, 326  
 Stevenson, Thomas, 7, 43, 84, 89  
 Stewart, Professor Balfour, 147, 303  
 Stocke, Dr. Leonard, 250  
 Stokes, Professor Sir George G., 109,  
     110, 111, 246, 271, 274

- Stow, Rev. Fenwick W., 101, 225  
 Strachan, Richard, 79, 118, 152, 154, 159  
 Stupart, R. F., 69, 71, 158  
 Sturt, Captain, 375  
 Supan, Dr. A., 221, 261, 355  
 Sutton, J. R., 156  
 Swan, W., 459  
 Sydenham, Dr. Thomas, 410  
 Symons, George J., 26, 33, 105, 128, 170, 186, 204, 209, 223, 226, 228, 239, 240, 241, 247, 248, 254, 258, 261, 311, 396, 466
- TATT, 322  
 Tatham, Dr. John, 106  
 Theophrastus of Lesbos, 2  
 Theorell, Dr., 93, 129  
 Thompson, R. Campbell, 2  
 Thomson, Sir Joseph, 244, 245, 246, 293  
 Thomson, Sir William (see "Lord Kelvin"), 13, 298, 299, 300, 301  
 Thorne, Sir R. Thorne, 432  
 Thrift, Professor W. E., F.T.C.D., 107, 329, 403  
 Thurston, Edgar, 447  
 Tissandier, M. G., 22, 326  
 Torricelli, Evangelista, 114, 115, 118  
 Townley, R., 224  
 Toynbee, Captain, 381  
 Trabert, Wilhelm, 259, 340, 341  
 Tripp, 221  
 Trouton, Professor F. T., 178, 179  
 Tucker, Edward, jr., 209  
 Twemlow, Francis E., 323  
 Tyndall, Professor John, 186, 197, 205, 249
- UPTON, Professor Winslow, 67
- VAN MARUM, 321  
 Van Rysselberghe, Professor F., 93, 129
- Vernier, Pierre, 141  
 Verz, F. W., 260  
 Vidi, 132  
 Violle, Professor, 102  
 Volta, Alessandro, 255, 294, 295, 297, 313
- WALDO, Professor Frank, 66  
 Wall, Dr., 294  
 Wallis, 123  
 Wallis, H. Sowerby, 248  
 Ward, Colonel, 225  
 Warren, Rev. Isaac, 264  
 Webster, W. H. B., 265  
 Wells, Charles William, 190  
 Wheatley, Colonel, 164  
 Wheatstone, Sir Charles, 93, 128, 311  
 Whewell, 274, 285  
 Whipple, G. M., 109, 110, 285  
 White, Margaret, 306, 333  
 Wiesner, 242  
 Wild, Professor, 270, 354  
 Wilke, Professor, 271  
 Williams, 426  
 Williams, Dr. C. Theodore, 351, 355, 362, 365, 372  
 Wilson, C. T. R., 244, 245, 246, 306  
 Wilson, Dr. Alexander, 325  
 Wilson, Dr. W. E., 104  
 Wilson, Patrick, 190  
 Wilson, Sydney, 358  
 Wistrand, Dr. 439  
 Wojeikof, A., 365, 366, 367, 369, 370  
 Wolf, 271  
 Wollaston, 274  
 Woltman, 274  
 Wren, Sir Christopher, 223
- YEATES, George, 229  
 Young, Dr. Thomas, 77
- ZAMBRA, 83, 84, 228, 234, 235, 275

THE END





UNIVERSITY OF CALIFORNIA LIBRARY,  
BERKELEY

THIS BOOK IS DUE ON THE LAST DATE  
STAMPED BELOW

Books not returned on time are subject to a fine of  
50c per volume after the third day overdue, increasing  
to \$1.00 per volume after the sixth day. Books not in  
demand may be renewed if application is made before  
expiration of loan period.

NOV 6 1928

JUN 1 1931

7 May '56NW

APR 23 1956 LU

YC 10847

*juva*  
*us*



*Indicator*



