

Catalog of Meteorological Instruments
in the
Museum of History and Technology

W. E. Knowles Middleton

QC
876
M98
UNIVERSITY OF MICHIGAN

Catalog of Meteorological Instruments
in the
Museum of History and Technology

SMITHSONIAN STUDIES IN HISTORY AND TECHNOLOGY

NUMBER 2

Museum of History and Technology (U.S.)



Catalog of Meteorological Instruments
in the
Museum of History and Technology

Prepared by

W. E. Knowles Middleton

SMITHSONIAN INSTITUTION PRESS

CITY OF WASHINGTON 1969

NAT. HIST.

M.

N. D. C.

60013

WITHDRAWN

For sale by the Superintendent of Documents, U.S. Government Printing Office
Washington, D.C. 20402 - Price \$3.25

Contents

	<i>Page</i>
Acknowledgments	3
1. INTRODUCTION	3
2. BAROMETERS AND BAROGRAPHS	7
Invention of the Barometer	7
Mercury Barometers and Barographs	8
Aneroid Barometers and Barographs	23
Other Instruments	33
3. THERMOMETERS AND THERMOGRAPHS	37
Early History	37
Liquid-in-Glass Thermometers	38
Maximum and Minimum Thermometers	45
Bimetallic Thermometers	49
Recording Thermometers	50
Other Instruments	55
4. INSTRUMENTS FOR THE MEASUREMENT OF ATMOSPHERIC HUMIDITY	61
Absorption Hygrometers	61
Condensation Hygrometers	64
Psychrometers	66
Other Instruments	70
5. INSTRUMENTS FOR THE MEASUREMENT OF PRECIPITATION AND EVAPORATION	73
Other Instrument	77
6. INSTRUMENTS FOR MEASURING THE SURFACE WIND	79
Wind Vanes and Wind-Direction Recorders	79
Anemometers and Anemographs	82
Other Instruments	89
7. SUNSHINE RECORDERS	91
Other Instrument	93
8. NEPHOSCOPES	95
9. UPPER-AIR INSTRUMENTS, NOT TELEMETERING	97
Meteorographs for Use With Kites or Captive Balloons	98
Meteorographs for Use With Free Balloons (Sounding Balloons)	99
Meteorographs for Use on Aircraft	100
Miscellaneous Apparatus Used in Connection With Upper-Air Observations	102
10. RADIOSONDES	103
Other Instruments	120
11. MISCELLANEOUS METEOROLOGICAL INSTRUMENTS	123
Combination Recording Instruments	123
Other Instruments, Not Classified	124
Bibliography	128

Introduction

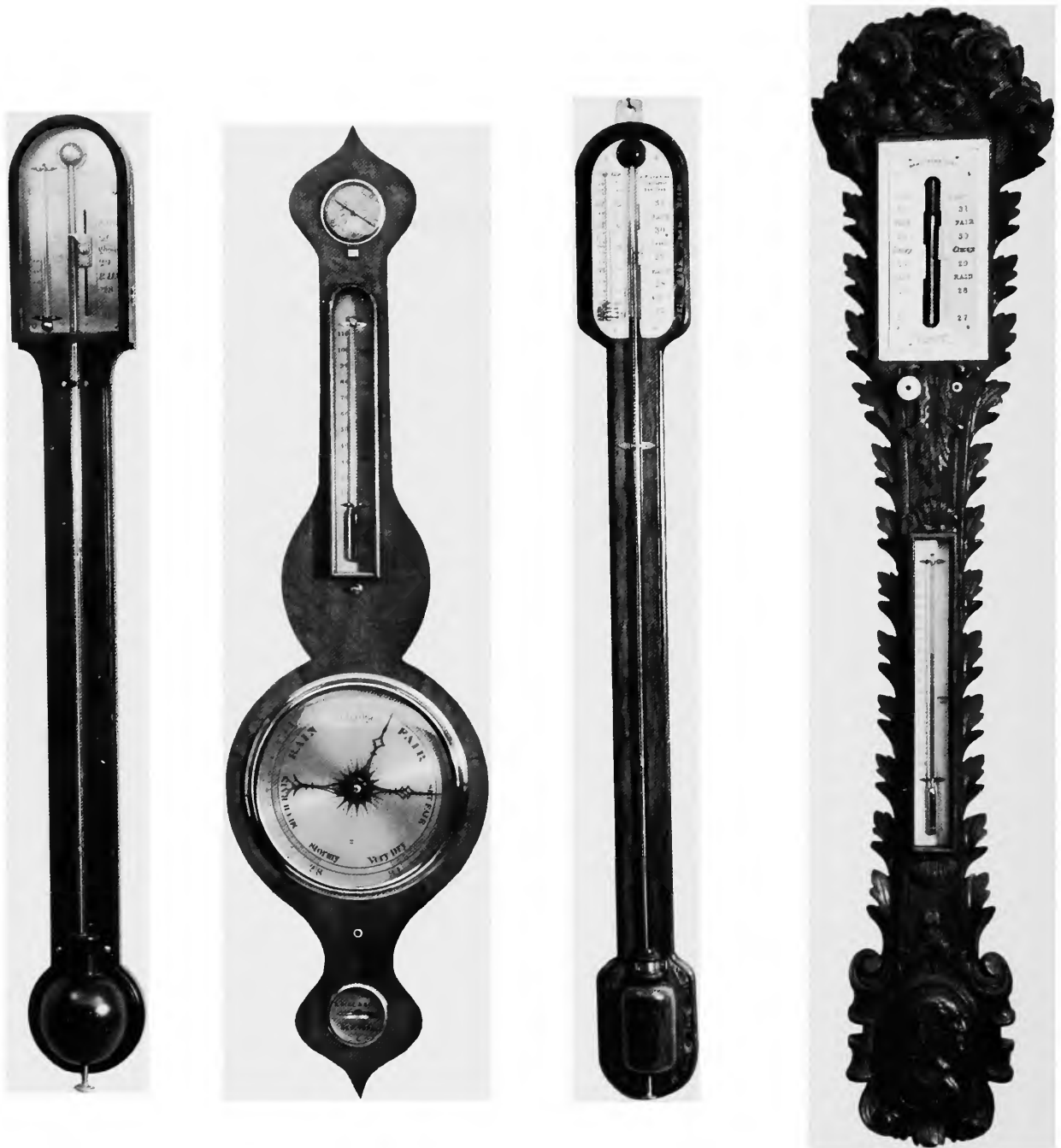

FIGURE 1

Four barometers by Benjamin Pike & Sons, New York (MHT 316,739, MHT 319,958, MHT 323,000, and MHT 326,144). (Smithsonian photo 61909.)

Chapter 1

Introduction

In dealing with its collections of scientific instruments, generally assembled largely by chance, a great museum has to pay attention to its function as a means of public education, while meeting its obligation to provide materials for study by specialist scholars. Those who walk in the public galleries of such an institution and admire the skillfully arranged exhibits seldom have any idea of the mass of material, in depositories and storerooms, of which only a small sample can possibly be displayed. Were they to visit such a storeroom with its complexities of ordered disorder, they would probably be unable to make much of what they saw. Nor would they find what they saw very attractive; for, as every curator knows, old instruments coming to a museum nearly always need a good deal of expert refurbishing and restoring before they are fit to be put in an exhibition case; and unless they are to be exhibited, they do not receive it.

The scholar is often obliged to do a good deal of mental restoration. This remark applies with particular force to meteorological instruments many of which in their years of service have necessarily been exposed to the weather. Indeed, this circumstance conditions the relative numbers of meteorological instruments of different types to be found in collections. In the European museums with which the writer is acquainted, the pattern is the same as in the Smithsonian

Institution's Museum of History and Technology: the most numerous instruments are thermometers, which do not deteriorate much unless they are actually broken—though not many are very old—followed by aneroid barometers and barographs, which are generally kept indoors. Mercury barometers are often fairly common, and mercury barographs are frequently both numerous and well preserved, probably because even an unhistorically minded meteorologist would hesitate to break up such a complex and elegant piece of apparatus. But when it comes to things that went on poles, like anemometers, it is another story. Only a few are likely to have survived.

The collection to which this catalog is devoted came to the Museum from many sources, but

Acknowledgments

Information regarding a number of instruments has been obtained from several people whose kindness is acknowledged in footnotes. Here, the writer must specially refer to the great assistance he received from Mr. Christos Harmantas of the U.S. Weather Bureau in the matter of radiosondes, on which Mr. Harmantas is a recognized authority.

somewhat more than half of these instruments came from the principal centers of official meteorological observation in the United States. Federal government activity in relation to meteorology seems to date from 1819, when the office of the Surgeon General, U.S. Army, initiated systematic observation of the thermometer and wind vane at military posts. In 1855 the young Smithsonian Institution made meteorology one of its first concerns, distributing instruments around the country and correlating the observations which were reported via the recently developed telegraph network. In 1870 the Signal Corps, U.S. Army, took on the burden of official meteorology as a result of a joint resolution of the Congress and in accordance with Joseph Henry's dictum that the Smithsonian should not become the agency for such scientific work once its permanency had been decided upon. This did not terminate Smithsonian meteorology altogether, however, for at the end of the century the establishment of the Astrophysical Observatory by Henry's successor, S. P. Langley, re-involved the Institution in observations related to solar physics.

The decade of the 1860s marked the transformation of observational meteorology from a largely haphazard occupation of amateur observers, using simple instruments, into a more businesslike and systematic procedure pursued in permanent stations and using sophisticated instruments the results of which were automatically recorded or read at a distant point. In the 1870s the Army Signal Corps acquired examples of most of the existing "systems," and installed them in a laboratory for the development of new types of instruments. Along with several European systems shown, there were two from American meteorologist-inventors—George Hough, Director of the Dudley Observatory, Albany, New York, and Daniel Draper, who had a private observatory in Central Park, New York City.

In 1891 U.S. Government Meteorology moved again, this time to the Department of Agriculture, where it became a subordinate unit with the title U.S. Weather Bureau. In 1940 the unit was

transferred to the Department of Commerce, and in 1966 it became the nucleus of a new bureau, the Environmental Sciences Administration. This unusually peripatetic history accounts for the miscellany of sources from which the instruments in this collection derive, for they represent the principal repository of the remains of official meteorology in the United States.

The instruments in this Museum represent many donors, but the majority came from the American sources just mentioned. Our particular gratitude goes to Mr. Robert Wright of the U.S. Weather Bureau, who for many years has been alert to the history of his own field, and whose personal intervention has often prevented the discarding or cannibalization of important instruments which are now in the Museum of History and Technology.

In the 19th century it was believed that "science" and "measurement" were almost synonymous terms. While this attitude has been modified, it remains true that the availability of suitable instruments has at all times been immensely important to the advance of science. Meteorology as a scientific discipline began immediately after the invention of the barometer, and as a result of it.¹ In more recent times our knowledge of weather processes has been enormously enlarged by the use of instruments for measuring temperature, humidity, surface wind, and other elements, and especially by the development and use of means of investigating the upper air. Therefore, the history of meteorological instruments is an important part of the story of the science of meteorology.

The most ancient of these instruments is probably the wind vane for facilitating the observation of the direction of the wind. The rain gauge is also of a respectable antiquity. Next came the invention of a crude sort of hygroscope in the 15th century, and one type of anemometer was envisaged, if not built, at about the same

¹ See W. E. K. Middleton, *A History of the Theory of Rain* (London: Oldbourne, 1965; New York: Franklin Watts, 1966), especially chapter 4, for evidence of this.

time. The wonderful 17th century brought the barometer and thermometer, both carried to a useful degree of precision in the 18th century. The invention of the balloon in 1783 led at once to the investigation of the upper air, though more than a century had to elapse before the development of light instruments for unmanned balloons and kites made anything more than sporadic observations possible. Finally, in our own time, the progress of electrical engineering, giving us the radiosonde and radar, has made upper-air observations a regular part of the data furnished every day to the forecaster.

This catalog contains a short summary of the history of each type of instrument, accompanied by descriptions of the more interesting or important specimens in the collection, introduced

at appropriate places, but set apart typographically so that the narrative can easily be read through by itself if the reader prefers to do this. At the end of each chapter will be found a list of the other instruments in the Museum that have not been discussed in the text. While most of the instruments described are in the collections of the Museum of History and Technology (MHT), a few are in the collections of the National Air and Space Museum (NASM). The Museum of History and Technology is naturally rich in apparatus of American origin, and an attempt has been made to cover such specimens in some detail without overemphasizing their importance in the history of meteorological instrumentation. It is thought that the typographical arrangement will contribute to this end.

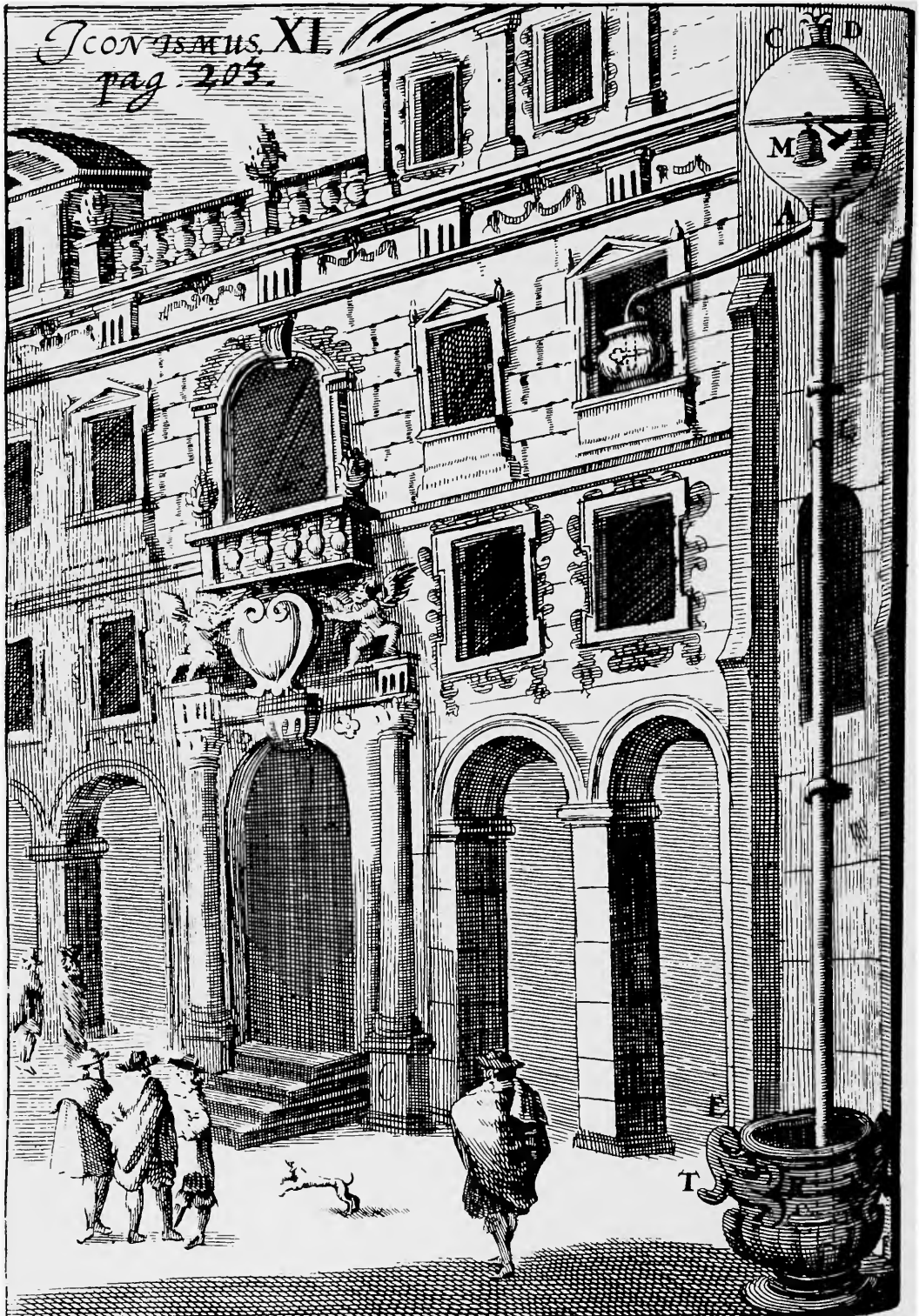

FIGURE 2

Berti's experiment. (Plate 12 from *Technica curiosa, sive mirabilia artis* by Gaspar Schott, 1687, opposite page 203; Smithsonian photo 60824.)

Chapter 2

Barometers and Barographs

Invention of the Barometer

The barometer, which lies at the very foundations of meteorology, is also an instrument of great philosophical importance, for its invention, and the experiments made with it, finally disposed of the long-cherished dogma of the impossibility of a vacuum. At the beginning of the 17th century several people, notably Isaac Beeckman and Galileo Galilei, were sure that a vacuum could exist, though Galileo, strangely enough, never believed in the pressure of the air.² The great French philosopher René Descartes, on the other hand, made up his mind that all space must be filled with something, so that a vacuum is quite impossible; and Descartes, as is well known, seldom let his mind be changed by experiments.

Experiments began to be performed, especially in Italy. The first that is of concern to us here was done in Rome by Gasparo Berti (d. 1643) sometime after 1639, and probably before 1642. Berti, watched by a number of people interested in "natural philosophy," fastened a lead tube to the wall of his house, with a glass flask at the top,

provided with a screw plug. The bottom of the tube, which had a stopcock on it, was under the water in a cask that stood on the ground (figure 2). This stopcock was first closed, and the tube and flask completely filled with water from the top. The plug was then replaced; and when the stopcock was opened, the water went out of the flask, leaving an apparently empty space. The stopcock was then closed again and the plug loosened, whereupon the air rushed into the flask "with a loud noise," demonstrating that the flask had been empty. A sounding line showed that the water in the tube was 18 cubits (about 10 meters) above the level in the cask.³

Berti was trying only to find out whether a vacuum could be produced, and cannot be credited with the invention of the barometer. Indeed, the pressure of the air was not even adduced as an explanation of the suspension of the column of water in the pipe. The conscious invention of the instrument that became the barometer must be ascribed to Evangelista Torricelli (1608–1647). His part in the story is

² For more details, see W. E. K. Middleton, *The History of the Barometer* (Baltimore: Johns Hopkins Press, 1964).

³ The full account by Emmanuel Maignan (1601–1676) from his *Cursus philosophicus* . . . (4 vols. paged as one, Toulouse, 1653), pp. 1925–36; for translation, see *ibid.*, pp. 10–15.

known solely from three letters exchanged between Torricelli and Michelangelo Ricci (1619–1692), and dated 11, 18, and 28 June 1644.⁴ Torricelli's first letter describes the famous experiment made by his young student Viviani in which tubes full of mercury were inverted in a dish of that liquid, whereupon the mercury in the tubes fell to about 75 cm above the level in the dish. Torricelli ascribed this suspension to the weight of the air; and in his letter of 28 June, in answer to Ricci's questions, showed that he realized that the air was elastic as well as heavy.

It is not known whether Torricelli and Viviani ever applied a scale to their tube—in fact there is no evidence of Torricelli's further interest in the barometer after 1644—but he had announced in his first letter that he was trying “to make an instrument to show the changes of the air,” and for this reason the invention of the barometer is rightly credited to Torricelli. The first use of a scale that we know about is due to Descartes, who on 13 December 1647, drew two similar scales on paper and sent one to Marin Mersenne, so that they might make comparable observations.⁵

Mercury Barometers and Barographs

The earliest technical improvement on the Torricellian tube was the siphon barometer, invented by the French mathematician and mystic Blaise Pascal (1623–1662) before about 1650.⁶ The siphon barometer, which appears as one of the three instruments in MHT 319,794,⁷ had some slight advantages in portability over

⁴ First printed by Carlo Dati in his *Lettere a Filaleti di Timauro Antiata* . . . (Florence, 1663); the second, from Ricci, only in part. They are in Torricelli, *Opere*, eds. G. Loria and G. Vassura. (Faenza, 1919) vol. 3, pp. 186–88, 193–95, 198–201.

⁵ Descartes, *Oeuvres*, eds. Charles Adam and Paul Tannery (Paris, 1897–1913), vol. 5, p. 99.

⁶ Pascal, *Traicté de l'équilibre des liqueurs et de la pesanteur de la masse de l'air* . . . (Paris, 1663), p. 100.

⁷ See p. 10.

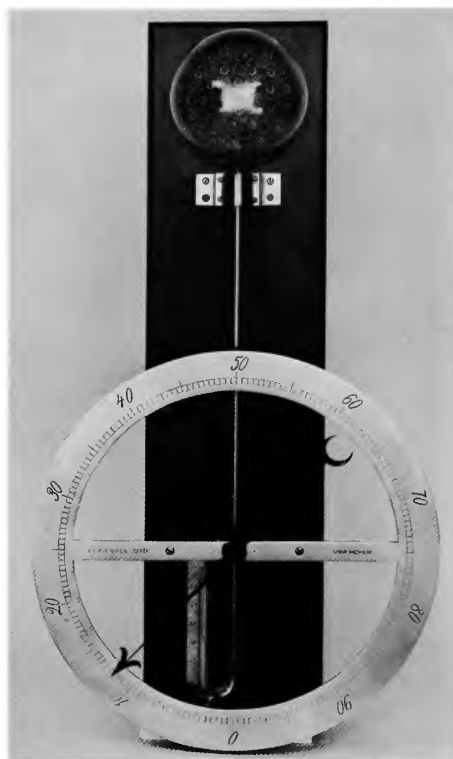

FIGURE 3

MHT 316,857. Hooke's wheel barometer. A reproduction marked “L. C. Eichner fecit anno MCMLIX” of the version described in the *Micrographia*. It is mounted on a wooden frame 96 cm high. The bulb at the top is 18 cm in diameter and the brass scale is 53 cm in diameter. (Smithsonian photo 61903.)

the Torricellian tube, but to an age quite unaccustomed to fine measurements, the diminution of the movement of the upper mercury surface because of that of the lower one was a serious disadvantage. In fact, the history of the barometer for the rest of the 17th century is largely a record of attempts to expand the scale of the instrument to make it easier to read. It should be noted that this would not necessarily increase the real accuracy of reading.

One of the earliest and eventually the most popular of these expanded-scale barometers was the “wheel barometer” invented, probably in December 1663, by Robert Hooke (1635–1703,)

“curator of experiments” to the newly formed Royal Society. The Museum possesses a replica constructed according to Hooke’s engraving (figure 3).⁸ It will be seen from the figure that this is a large siphon barometer with a float in the shorter limb. This float is attached to a thread which passes over a pulley, on the shaft of which is a pointer moving over a scale. A small weight partly counterpoises the float. The upper surface of the mercury was at the diametral plane of the large bulb, in order to throw nearly all the motion of the mercury into the short limb; but later⁹ Hooke realized that this was not important, and lengthened the tube to allow more room for any air that might remain in the tube, altering the diameter of the pulley accordingly.

Thousands of wheel barometers were made, especially in decorated cases of “banjo” shape for household use. The Museum has a 19th-century example (MHT 308,173).

MHT 308,173. Household wheel barometer, showing from top to bottom a hygrometer (twisted gut), a spirit thermometer, a convex mirror, the barometer dial graduated from 28 to 31 inches in hundredths, and a bubble level surrounded by a plate carrying the legend “D. Fagioli & Son 39 Warner St. Clerkenwell.” Overall length 96 cm, extreme width 26 cm. Presented by Taylor Instrument Companies, Rochester, N.Y.

Hooke himself incorporated a barograph in his famous meteorograph or “weather clock,”¹⁰ and it was probably an adaptation of the wheel barometer. Many barographs since then have operated on the same principle,¹¹ and the Museum has a specimen of a recent and successful one (MHT 316,500, figure 4), designed about 1904 by C. F. Marvin of the U.S. Weather Bureau.¹²

Hooke knew that friction and dirtying of the mercury would limit the usefulness of such barometers and cast about for another means of

FIGURE 4

MHT 316,500. Marvin’s compensated barograph, 1904. A siphon barometer with a tube 3.8 cm in diameter has a float in the short leg. A cord from the float passes over a pulley to a counterweight. The pen is supported from a larger pulley on the same shaft, so that the pressure changes are magnified five times on the drum, which is 13.5 cm in diameter and 28 cm long. The chart is graduated from 28.80 to 30.80 inches. The clock that drives the drum has a handsome dial. The baseplate is marked “Compensated Barograph N^o 1 Marvin System Made by Schneider Brothers, N.Y.” This instrument is compensated for changes of the ambient temperature by designing the tube so that it will have the proper volume of mercury in it. This possibility was mentioned by various people, first, probably, by G. W. Hough in *Annals of the Dudley Observatory, Albany, N.Y.*, volume 1 (1866), pages 88–90. There is a glazed case for this barograph, 216 cm high and 46 cm wide x 33 cm deep. Transferred from the Weather Bureau in 1959 (Smithsonian photo 46740–E.)

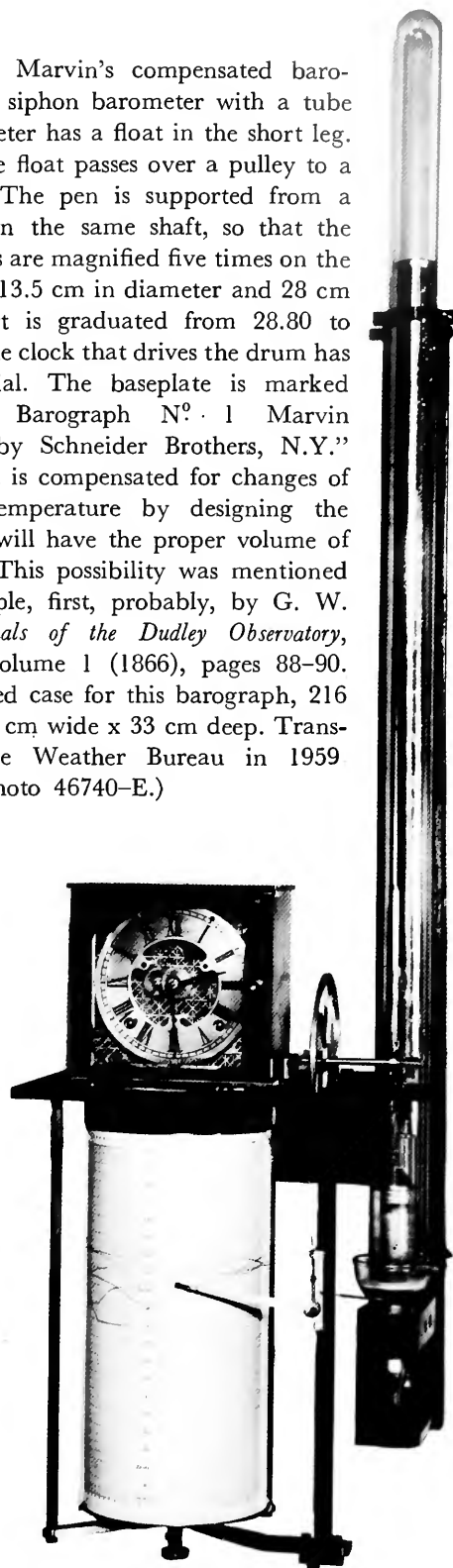

⁸ Hooke, *Micrographia* . . . (London, 1665), plate 1.

⁹ *Phil. Trans.*, vol. 1 (1666), pp. 218–19.

¹⁰ W. E. K. Middleton, *Physis*, vol. 3 (1961), pp. 213–22.

¹¹ *Op. cit.* (footnote 2), pp. 287–97.

¹² C. F. Marvin, *U.S. Monthly Weather Review*, vol. 36 (1908), pp. 307 and 313.

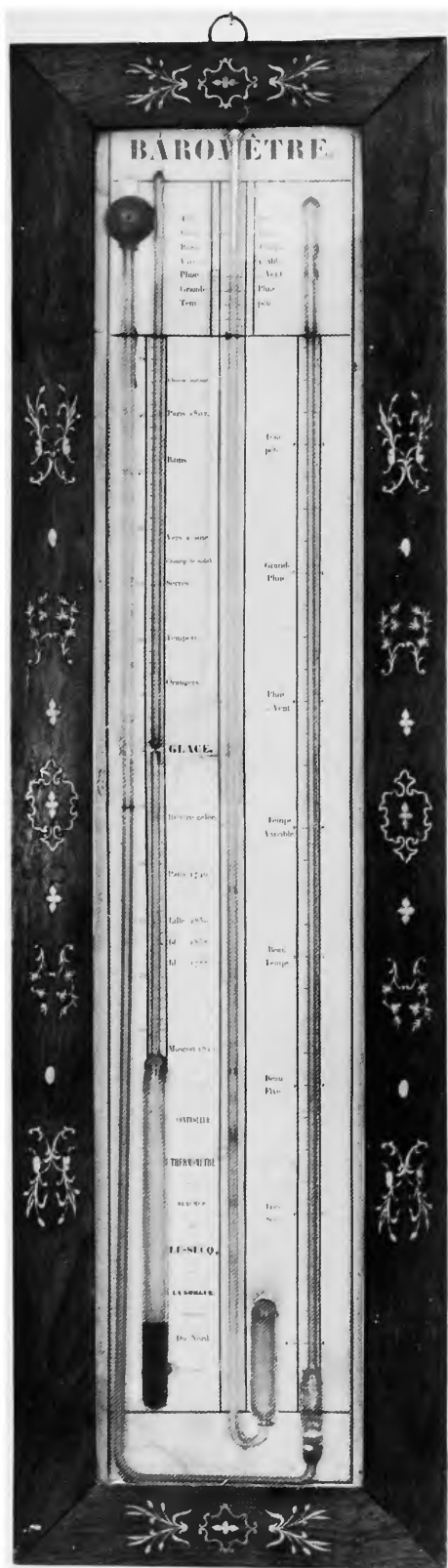

FIGURE 5

MHT 319,794. Barometer, "Controleur," and thermometer. A wooden frame 28 x 98 cm decorated with marquetry, enclosing a paper panel on which are mounted three separate instruments: a Réaumur thermometer, a simple siphon barometer, and a "Controleur," i.e., a two-liquid barometer of Hooke's type. This last has a scale divided into 32 divisions, with words from "Très sec" to "Tempête" at each fourth division. The front of the instrument is glazed. The dates of various record temperatures, the latest 1812, are given near the thermometer. Marked "Controleur et Thermomètre selon Réaumur Par Le-Secq, de La Gorgue, Department Du Nord." Received in 1961. (Smithsonian photo 61903-A).

expanding the scale, arriving first at the so-called "double barometer" or two-liquid barometer which he demonstrated to the Royal Society in 1668.¹³ The cylindrical bulbs are long enough to accommodate pressure changes, and the reading is taken from the water surface. This barometer shows changes of pressure very well, but suffers from evaporation, and it became very common to mount one of these instruments and a siphon barometer on the same board, often with a large thermometer, as in the example (MHT 319,794) shown in figure 5, which dates from about 1815. The double barometer in this combination came to be called a "Controleur," "Controlleur," or "Contrarolleur," for reasons which are not quite certain.

Hooke also invented¹⁴ a barometer using three liquids—mercury, alcohol, and turpentine—which could give any magnification desired.

Another means of expanding the scale of a barometer was to hang either the Torricellian tube or its cistern from one arm of a balance. Marin Mersenne (1588–1648) had weighed the

¹³ Thomas Birch, *History of the Royal Society* (London, 1756–57), vol. 2, p. 298.

¹⁴ *Phil. Trans.*, vol. 16 (1686), pp. 241–44. The invention of both these barometers has been claimed for others. See also op. cit. (footnote 2), chapter 6.

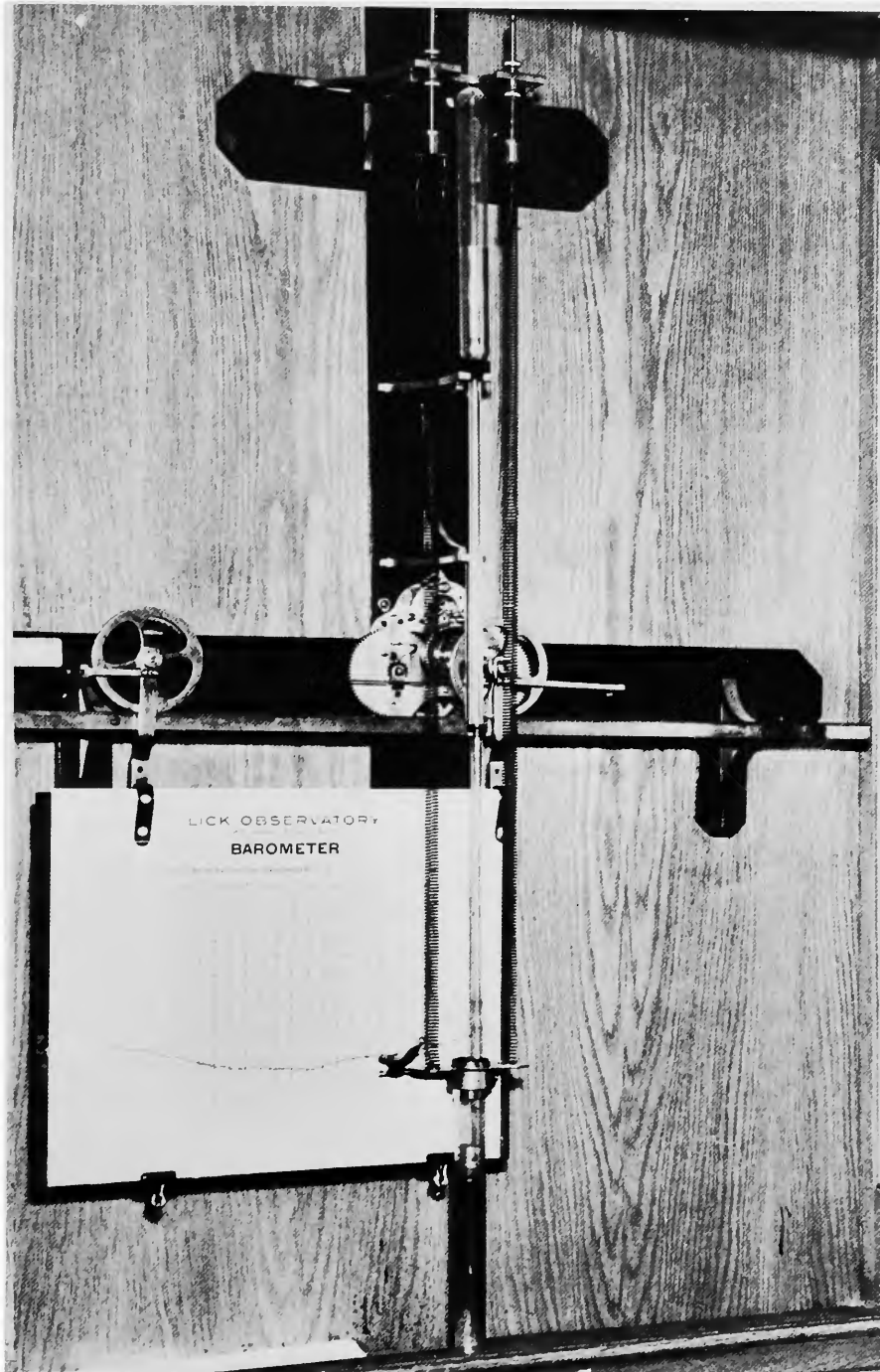

FIGURE 6

MHT 316,941. Draper's balance barograph. The cistern is hung on springs and is connected to the recording pen. As the mercury falls from the tube into the cistern, the pen is deflected downward. The flat chart is moved horizontally

by clockwork. Height 76 cm, width 70 cm. This one was used for many years at the Lick Observatory, and was presented by the University of California in 1960. (Smithsonian photo 46751.)

tube in this way by 1647,¹⁵ but it was not until about 1679 that Sir Samuel Morland used this scheme to make a barometer.¹⁶ Such barometers never became popular, but the principle of weighing was used in several elaborate barographs towards the end of the 19th century, and the Museum possesses one (MHT 316,941, figure 6) designed by Daniel Draper of New York about 1884.¹⁷ This one was used at the Lick Observatory in California.¹⁸

Sir Samuel Morland,¹⁹ and apparently also Bernardo Ramazzini of Modena,²⁰ invented another sort of instrument known as the diagonal barometer, in which the top of the tube is bent through nearly a right angle, so that a small rise in the column of mercury corresponds to a much larger distance along the sloping tube. Such instruments became popular as household weatherglasses, especially in England, and their peculiar shape was sometimes taken advantage of in combining them with a thermometer and mounting them with a mirror or, as in the example in the Museum's collections (MHT 319,469), with an engraving as shown in figure 7.

Various other methods of expanding the scale of the barometer have been devised during the last three centuries, none of which are represented in the collections.²¹

A barometer, in the form of a Torricellian tube, was first carried up a mountain by Florin Perier on 19 September 1648,²² and the results

convinced most people of the pressure of the air. But Perier had to set up the Torricellian experiment afresh at the top of the mountain. Later, the desire of travelers for portable barometers had a great influence on the design of these instruments. It is impossible to deal with all the devices that were used to make barometers easier to transport, but most of them fall into two groups: special constructions of the cistern, and improved versions of the siphon barometer. As early as 1688 it was discovered that various kinds of hardwood—especially boxwood—are impervious to mercury but will permit the passage of air, at least along the grain; and for two centuries boxwood formed a part of the cisterns of most portable barometers, allowing them to be otherwise closed. Some of these cisterns had leather bottoms, with a screw plunger for adjustment, but such barometers were most probably intended for installation in a house at some distance from where they were made—they were transportable rather than portable. The Museum possesses an example, not quite complete (MHT 326,225).

MHT 326,225. Barometer inscribed "J^N. Bon & C^o. Dundee." This is a fixed-cistern barometer with the cistern enclosed in a brass box, the tube in a rectangular mahogany case. Near the top of the case a door, with a Fahrenheit thermometer mounted on the back of it, covers a V-shaped recess of which the scale of the barometer forms the walls. The actual cistern is of boxwood with a leather bottom; a plunger for adjusting this is evidently missing. The scale is in tenths of an inch from 27.5 to 31.4. No vernier, but a simple pointer operated by a rack and pinion, the knob being lost. Overall length, 95 cm. Presented by Miss Elsie Howland Quinby, Washington, D.C.

A different way of adjusting the amount of mercury in the barometer, or of filling the cistern for transport, was by overflow, providing a plugged hole at an appropriate height on the cistern. If the barometer was laid flat and the plug removed, the cistern could be filled; then if it was placed erect, mercury would run out

¹⁵ Mersenne, *Novarum observationum physico-mathematicarum Tomus III* (Paris, 1647), first preface.

¹⁶ See W. E. K. Middleton, *Notes & Records Royal Society of London*, vol. 20 (1965), p. 150.

¹⁷ Draper, *American Meteorological Journal*, vol. 1 (1884–5), pp. 332–34.

¹⁸ See *Publications of the Lick Observatory*, vol. 1 (1887), pp. 78–79.

¹⁹ John Smith, *A Compleat Discourse of . . . the Baroscope or Quicksilver Weather Glass* (London, 1688), pp. 1–2.

²⁰ Ramazzini, *Ephemerides barometricae mutinenses anni M. DC. XCIV* . . . (Modena, 1695), pp. viii–ix.

²¹ See Middleton, op. cit. (footnote 2), chapter 6.

²² Pascal, *Recit de la grande expérience de l'équilibre des liqueurs* . . . (Paris, 1648).

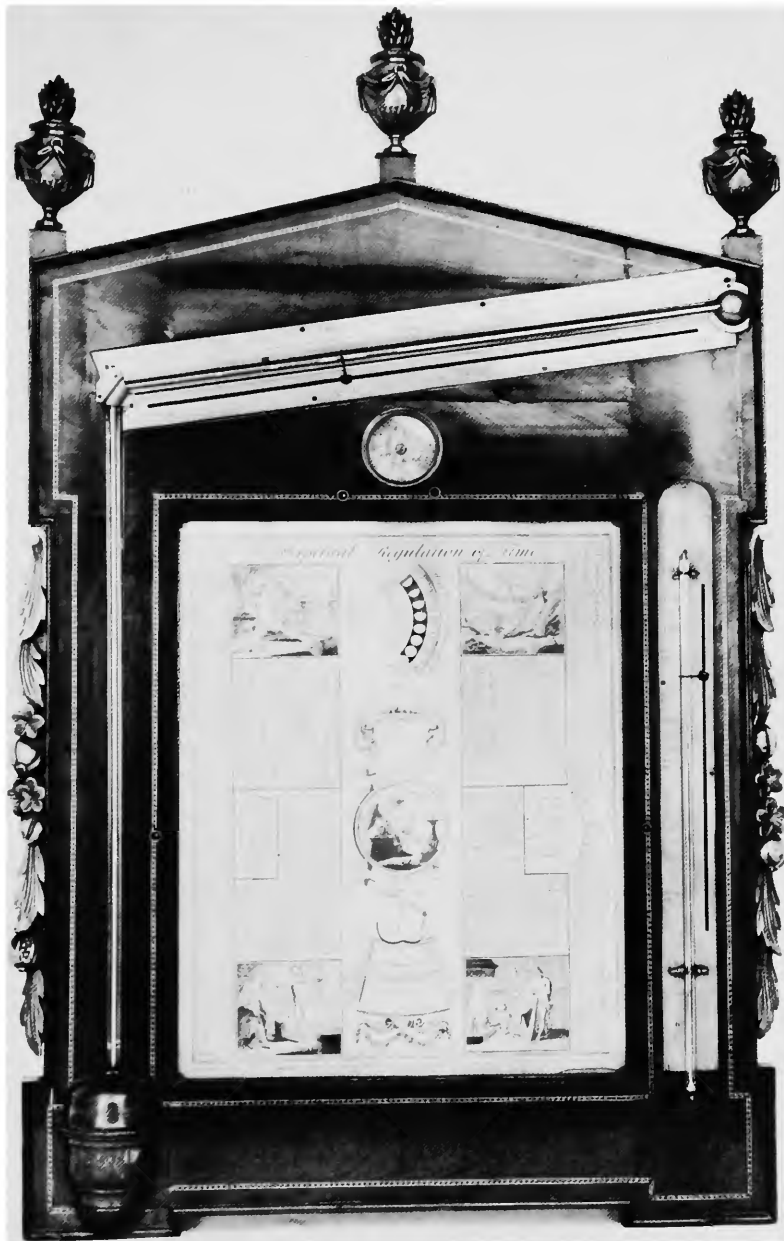

FIGURE 7

MHT 319,469. Diagonal barometer, thermometer, and hygrometer, late 18th century, by Watkins, London. A mahogany frame, 69 x 89 cm, decorated with typical 18th-century stringing and gilt carvings; three gilt brass urns at the top. Running up the left side and across the top is a diagonal barometer. The scale is graduated from 28 to 31 inches, with a magnification of about six. There is an index that moves along a

slot and can be set by hand. On the right side of the frame is a thermometer with a spherical bulb and a brass scale in Fahrenheit degrees, also with a setting pointer. Centered above the engraved perpetual calendar is a catgut hygrometer about 5 cm in diameter. It is interesting that a rather similar instrument in the Science Museum, London, has a copy of this same engraving. (Smithsonian photo 61910-D.)

until it was level with the lower edge of the hole. MHT 327,568 shows this feature.

MHT 327,568. Late-18th-century barometer almost entirely enclosed in a mahogany box 93 x 4.5 x 3.6 cm, with a very slender spirit thermometer 28 cm long, 10° to 212° F, on the front. The cistern is of wood with a screwed plug near the top. The scales of this and of the barometer (27 to 31 inches in tenths) are on box-wood inlays. A simple pointer, no vernier, the pointer on a small wooden block slid along a groove by hand. Inscribed "Brook Fecit Norwich." Received in 1966.

Another possibility for making the barometer portable is to divide the cistern into two volumes so proportioned that when the tube is quite full of mercury (having been inclined) the mercury just fills the lower compartment, which is then shut off from the upper one. This idea was Lavoisier's, according to Louis Cotte;²³ and John Frederick Newman used the idea with great success in the 1830s.²⁴ In 1860 L. Woodruff of Ann Arbor, Michigan, was awarded U.S. Patent 28,626 for such a cistern, and his barometer (MHT 314,608) is in the collection.

MHT 314,608. Mercury barometer patented by L. Woodruff. This has an iron cistern with a removable screw plug between upper and lower chambers. There is a scale in tenths of an inch graduated from 27 to 31 inches, and a vernier reading to 0.01 inch. The attached thermometer is in degrees F. The instrument is 94 cm long. The scale is inscribed "Charles Wilder Peterboro, N.H. Woodruff's Pat. June 5, 1860." Gift of Mrs. Hallie Stephens Caine, North Bend, Ohio.

Another sort of portable barometer, favored by mountaineers during the early 19th century, was the improved siphon barometer, with the internal diameter of both legs of the U-tube the same. This was characteristically made portable by means of a tap near the bend, as in the ingenious instrument of J. A. Deluc, designed

²³ *Traité de Météorologie* (Paris, 1774), vol. 1, p. 516.

²⁴ See also pp. 19-20.

FIGURE 8

MHT 325,753. Marine barometer, inscribed "Spencer Browning & Co. Minorities London." This has a mahogany case with a cistern-cover of brass. The actual cistern is of box-wood with a leather bottom; a plunger operated by a thumbscrew and permitting a little adjustment is concealed when the base of the cover is screwed on. The scale is graduated on ivory, 26.3 to 31 inches in tenths, with a vernier to 0.01 inch, but no index. Thermometer in °F + °R. Mounted in gimbals on a strong brass bracket. Overall length 92 cm. Received in 1964. (Smithsonian photo 61908-A.)



in the 1750s.²⁵ Another form, but without the tap, was devised by the famous chemist Joseph Louis Gay-Lussac (1778-1850);²⁶ this was made so that it could safely be carried upside down. The readings of the two scales are added or subtracted, according to their arrangement. The advantage claimed for the siphon barometer was that the capillary depression of the mercury surfaces could be neglected, because the tubes were of the same bore. It was not realized that it might be different for the surface in a vacuum and that exposed to the air. Nevertheless, the accuracy of the best siphon barometers was probably greater than that of simple cistern barometers such as those described so far.

Barometers for marine use presented a special problem, because the motion of the ship caused

²⁵ Deluc, *Recherches sur les modifications de l'atmosphère . . .* (Geneva, 1772), vol. 1, 64 ff. There was also an octavo edition (Paris, 1784).

²⁶ Gay-Lussac, *Ann. Chim. et Phys.*, vol. 1 (1816), pp. 113-19.

large oscillations of the mercury surface. The way of remedying this is to have a constriction in the tube, and this was first suggested by Robert Hooke on 2 January 1667/8²⁷ and reinvented by Edward Nairne more than a century later,²⁸ in the form of a length of capillary tubing near the middle of the barometer tube. The Museum has a typical marine barometer of the 1830s (MHT 325,753, figure 8).

As the need for accuracy became more pressing after about 1770, it was recognized that better means must be devised to measure the position of the upper mercury surface, and to bring the lower surface precisely to the zero of the scale. As to the upper surface, there was much argument about whether the top or the edge of the meniscus should be read, most simple barometers of the 18th century having indexes that would serve only for the latter alternative. The change to reading the top of the meniscus took place in England about 1775, when the famous instrument maker Jesse Ramsden (1735–1800) hit upon the idea of surrounding the barometer tube with a wide ring of somewhat greater diameter, having a plane lower surface, and making provision for illumination from the back, so that the plane of the bottom of the ring could be set tangent to the meniscus. When, towards 1800, it became common to use a brass tube 2 or 3 cm in diameter as the frame of the barometer, it was easy to cut slots front and back and to divide the vernier on a piece of the same tube cut to slide in the front slot. This construction may be seen in almost all the later 19th- and 20th-century barometers in the Museum (*e.g.*, MHT 314,712).²⁹ Ramsden's invention increased the precision of reading the upper surface by about tenfold.

Ramsden also seems to have made a contribution to the setting of the zero by providing a little ivory float in the cistern, but it was necessary to take out a plug and look into the cistern in

CATALOGUE
OF
MATHEMATICAL AND OPTICAL
INSTRUMENTS,

Philosophical and Chemical Apparatus,

CONSTRUCTED AND SOLD

BY

JAMES GREEN,

NO. 43 SOUTH STREET,

BALTIMORE,

AND

No. 175 BROADWAY,

NEW YORK.

1844.

FIGURE 9

Cover of James Green's first New York catalog.
(Smithsonian photo 60765.)

order to see it. Others, notably Antoine Assier-Perica, produced other designs with floats;³⁰ and introduced the use of cisterns constructed partly of glass, so that the mercury could be seen. An interesting one is due to Horner, apparently dating from just before 1800,³¹ in which the glass tube not only reveals the level of the mercury, but acts as a cylinder in which a rather complicated piston can be moved up and down in order

²⁷ Royal Society, *Classified Papers* XX, item 48. Autograph.

²⁸ C. J. Phipps, *A Voyage Towards The North Pole Undertaken by His Majesty's Command* (London, 1773), pp. 123–24.

²⁹ See p. 18.

³⁰ *Op. cit.* (footnote 2), pp. 208–10.

³¹ Gehler, *Physikalisches Wörterbuch* (Leipzig, 1825–45) vol. 1, pp. 784–85 and figures 154 and 155.

to adjust the level. The outer brass tube has windows front and back, extending a little above the edge of the top cap. It is to this edge that the mercury level is adjusted.

Our present interest in Horner's barometer is that its method of observing the level of the mercury was adopted, or possibly re-invented, by James Green, the first important maker of meteorological instruments in the United States. This excellent instrument maker established a business in Baltimore in 1832, and moved to New York in 1849, issuing a catalog, the wrapper of which is reproduced in figure 9.³² The firm name was changed in 1885 to "Henry J. Green"; Henry J. was James's nephew, and he later moved to Brooklyn, which was uniformly spelled "B'klyn" on all his instruments that this writer has examined.

James Green's first design of a portable barometer was exactly like Horner's in its way of establishing the zero of the scale, but the volume of the cistern was adjusted by deforming a leather bag by means of a plunger operated by a thumb-screw. The Smithsonian Institution bought some for distribution, and the Museum has one of these (MHT 224,424, figure 10) in its collections. This is probably the sort of instrument referred to by Joseph Henry in the *Report of the Commissioner of Patents for the Year 1855*.³³

A much better construction for a portable cistern barometer had been developed in France by the important instrument maker Nicolas Fortin, who made a happy combination of the glass-walled cistern, the ivory point, and the leather bag. His original design, described in 1809 by J. N. P. Hachette,³⁴ is an excellently conceived structure of brass, glass, and boxwood,

³² The date 1844 is a misprint; the verso of the wrapper contains a notice dated "New York, 1849." The title page makes it plain that this must have been a reissue of an earlier catalog first issued at Baltimore, probably in 1844.

³³ Washington, D.C., 1856, vol. 1, p. 370.

³⁴ *Programmes d'un cours de physique . . .* (Paris, 1809), pp. 221-25.

FIGURE 10

MHT 224,424. James Green's earlier portable barometer, marked "Smithsonian Instⁿ Ja^s Green" and (in much larger and more deeply engraved letters) "N.Y.," which may possibly indicate that it was under construction when the move was made in 1849. Length 94 cm; the brass frame 2.5 cm in diameter; the cistern 5.0 cm in diameter and 5.7 cm long. The scale is graduated in tenths of an inch from 24.8 to 32 inches, and the vernier reads to 0.01 inch. (Smithsonian photo 61910-A.)

FIGURE 11

MHT314, 625. Fortin barometer for mountain use, inscribed on the mounting of the attached thermometer "Ernst, Rue de Lille, N^o 11, à Paris (N^o 303)." Scale in millimeters from 400 to 825. Vernier to tenths, mounted on a friction-tight slide with a small knob, to be moved directly by hand. Protective brass tube only 1.4 cm in diameter. Glass cylinder of cistern 4.0 cm in diameter. Cistern and its outer case 11.5 cm long. Overall length 100 cm. Thermometer graduated from -24 to +52° C. Provenance unrecorded. (Smithsonian photo 61910-C.)



FIGURE 10

FIGURE 11

FIGURE 12

James Green's Fortin-type barometer. (U.S. Weather Bureau Circular F, 1894, page 7; Smithsonian photo 63883.)

which has been copied, with variations, by almost every maker of meteorological instruments from that day to this, usually under the name of "Fortin barometer." In fact, there is a tendency—even in some museum catalogs—to call any barometer in which the mercury is set to a point a "Fortin barometer." As we shall see, this is quite unjustifiable.

This Museum has a very beautiful example of this construction (MHT 314,625, figure 11), intended for mountain use and made by Ernst of Paris. The very long range of the scale and the extreme slenderness of the protecting tube are to be noted.

Probably the best and most durable design of Fortin-type barometer ever made is the celebrated instrument of James Green, first described in 1856³⁶ and supplied by him and his successors for almost a century, first to the Smithsonian Institution and later to the Signal Service of the United States Army, and to the Weather Bureau. The distinguishing characteristic of this design is the entire absence of glue or cement of any kind, and the avoidance of screw threads cut in boxwood. The construction of the instrument

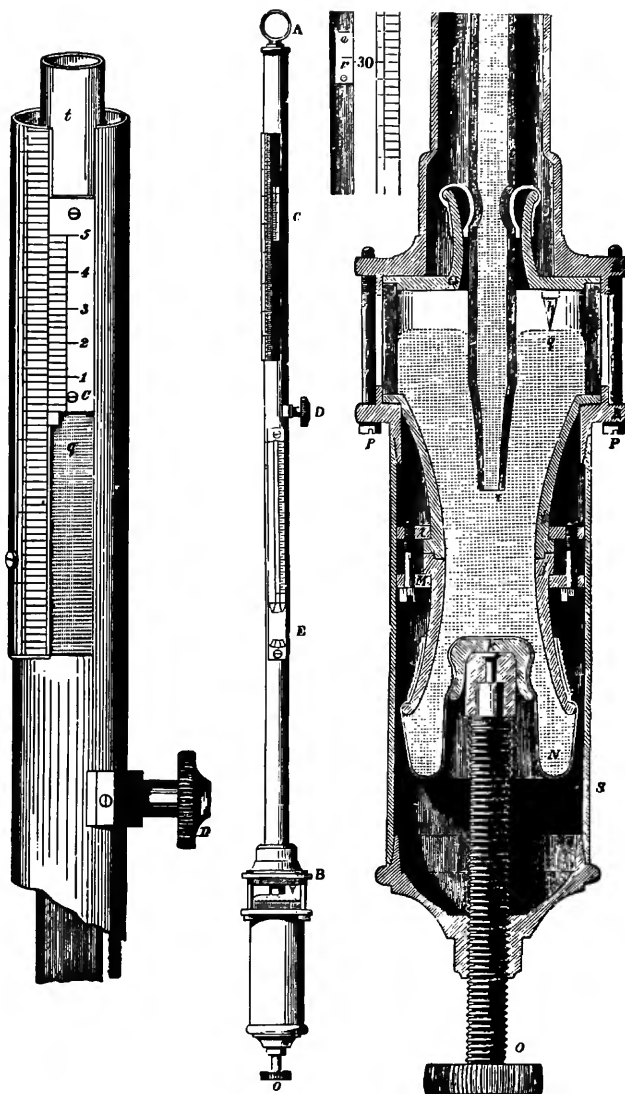

will be clear from figure 12,³⁶ with the remark that the two boxwood parts of the cistern, *i* and *j*, are held together by the two split rings *L* and *M*, and can be separated by removing one screw and loosening three others. If Fortin-type

³⁵ Smithsonian Institution, *10th Annual Report* (Washington 1856), pp. 251-58.

³⁶ From U.S. Department of Agriculture, Weather Bureau, *Barometers and the Measurement of Atmospheric Pressure Circular F. Instrument Room* (Washington, 1894). There have been numerous later editions.



FIGURE 13

MHT 314,942. Green's Fortin-type barometer, large model with tube about 12 mm bore and cistern about 60 mm. Total length 110 cm. The scale is graduated in 20ths from 25.5 to 32.6 inches, with a vernier to 0.002 inch, and in mm from 648 to 832, with a vernier to 0.05 mm. The thermometer is graduated in °F and °C on the tube, numbered on the frame, originally silvered. Cistern cover inscribed "Henry J. Green New York." This barometer, which dates from about 1890, was transferred from the Smithsonian Astrophysical Observatory in 1956. It is still in working order. (Smithsonian photo 61908.)

barometers are to be useful, the cisterns must be cleaned from time to time, and the great merit of James Green's design is that it makes this possible with little risk. The specimen (MHT 314,942, figure 13) in the Museum is a large example "after the English model,"³⁷ that is to say with the scale and vernier enclosed in a glass tube, a practice introduced by the instrument maker Patrick Adie about 1855, and still current.

In spite of the great durability of this construction, some people continued to distrust the leather bag, and at some time in the 1880s an adjustable cistern without one was designed by Charles B. Tuch of the Weather Bureau.³⁸ Like Horner, Tuch used a piston. The Museum has one of these barometers (MHT 314,712; see diagram, figure 14).

MHT 314,712. Barometer with the cistern designed by Charles B. Tuch, marked "H. J. Green B'klyn. N.Y." and also "Signal Service N^o. 160 A." It is 104 cm long overall, and the blackened brass tube that forms its frame is 2.1 cm in diameter. The scale is in tenths of inches from 26 to 33 inches, with a vernier reading to 0.01 inch. The attached thermometer is graduated from -20 to +125° F. Transferred from the Weather Bureau in 1955. (Smithsonian photo 61902-D.)

Of the other designs of an adjustable cistern in which the mercury is raised to touch a fiducial point, only two need be mentioned. The first is represented by MHT 325,999, and a cross section of the cistern is shown in figure 15, from which it will be seen that there is provision for closing the end of the tube for transport.

MHT 325,999. Mercury barometer, marked "Tycos Taylor Instrument Companies Rochester N.Y. N^o. 2179." This is a laboratory or station barometer with a cistern having a glass tube A, 4 cm in diameter, through which an ivory point G may be seen. The cistern proper forms a sub-assembly which can be moved up and down

³⁷ Catalog of Henry J. Green, 771 Broadway, New York, 1887, p. 14. It was a "Standard Observatory Barometer," and cost \$60.

³⁸ Op. cit. (footnote 36), p. 11.

by turning the screw F, in order to adjust the surface of the mercury to G. For transport, after inclining the instrument, the tube can be closed by the pad on the bottom of the cistern. The barometer is graduated from 650 to 825 mm and from 25.5 to 32.5 inches, with verniers reading to 0.1 mm and 0.001 inch respectively. There is an attached thermometer graduated in half degrees from -17 to $+50^{\circ}$ C. Overall length, 96 cm. Wooden case with lock. Provenance unrecorded.

The second (MHT 316,421) is ingeniously designed so that—apart from the point itself, and a gasket—the entire cistern can be molded from plastic materials in two parts.³⁹ It was intended as an instrument of moderate accuracy for schools.

MHT 316,421. Mercury barometer marked “Central Scientific Co. U.S. Patent Nos. 1,353,482 and 1,632,084.” The tube is enclosed in a light metal tube of hexagonal cross section; the cistern is of plastic material in two parts. The scale, on an attached flat plate, is graduated from 620 to 814 mm, with a vernier reading to 0.1 mm; and 26.5 to 32.0 inches, vernier to 0.005 inch. The vernier slide is moved directly by hand. Overall length, 87 cm. Transferred from the U.S. Military Academy in 1959.

Instead of bringing the mercury up to a point, why not bring a point, rigidly attached to the end of a scale, down to touch the mercury? This idea was probably thought of about 1780, but not widely applied. In the Museum, this principle is represented by an excellent large station barometer (MHT 314,941) by John Frederick Newman, which may have come to the Smithsonian Institution more than a century ago. This famous barometer was designed by Newman about 1839 to be sent out to observatories all over the British Empire, and it had to be portable as well as accurate, so Newman thought out a cistern which has the two square brass tubes between which the large barometer tube is supported. Inside one of these

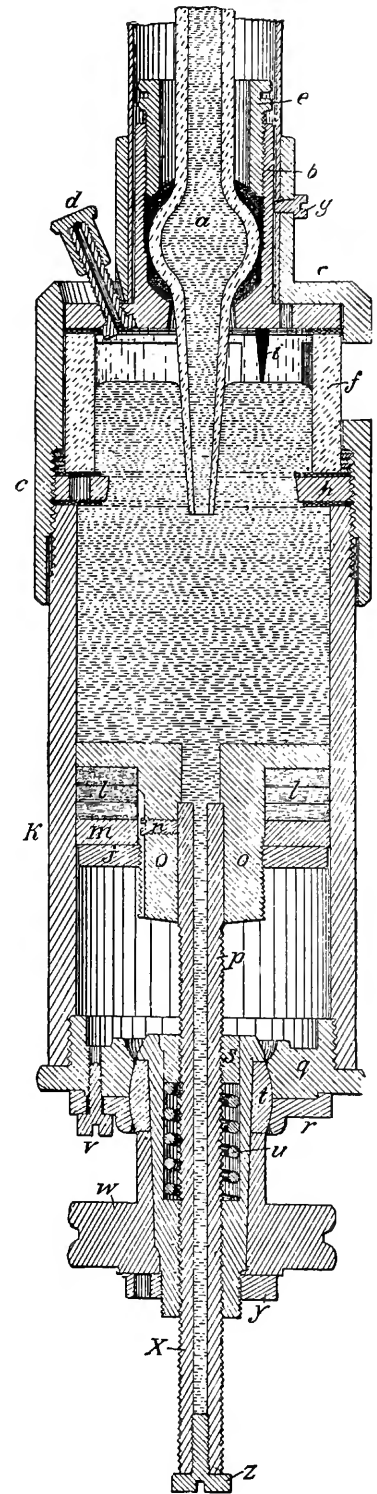

FIGURE 14
Tüch barometer cistern.

³⁹ Paul E. Klopsteg and H. P. Sachse, U.S. Patent 1,632,084 (1927). See also op. cit. (footnote 2), pp. 352–53.

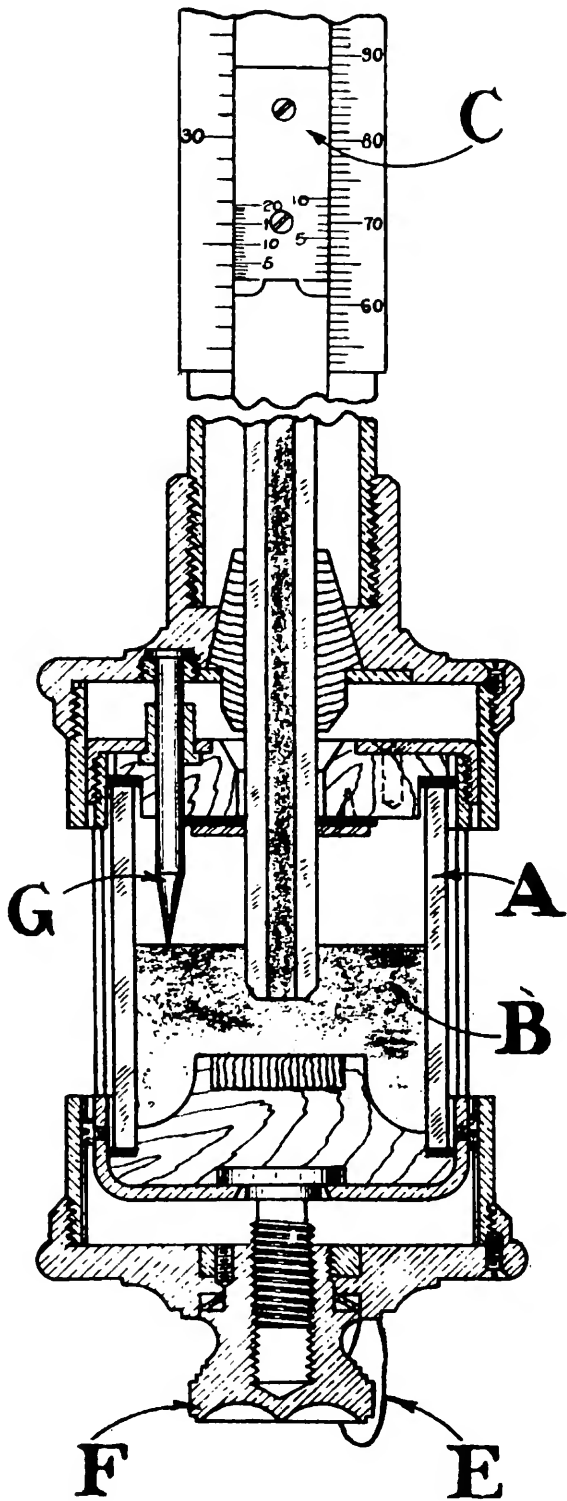

FIGURE 15

Adjustable cistern in which the tube can be closed for transport. (Smithsonian photo 61224.)

is the movable rod, tipped with ivory, which carries the scale at its upper end. This rod can be moved by a rack and pinion and passes into the cistern through a mercury-tight gland. The two main portions of the cistern are of iron.

To make this barometer portable it is slowly inverted, so that nearly all the mercury passes into the tube and the upper chamber of the cistern. The lower chamber is then turned on its central bearing so that the communicating part is closed off. In this state the instrument can be carried upside down or horizontally. The success of the design was shown by the fact that most of the instruments, taken out to their remote destinations and set up by soldiers, arrived not only intact but with their corrections almost unchanged.

MHT 314,941. Large station barometer with movable scale, marked "I. Newman 122 Regent St London" and "N^o 121 Temp^{re} 32 Diameter of the tube .562." (Temp^{re} 32" refers to the temperature at which the scale is standard.) The tube, 1.42 cm in internal diameter, is supported between two square tubes ending in a semicircular casting at the top, and attached to the cistern at the bottom. The movable scale has the lower part of iron, tipped with ivory, the upper part being a square brass rod to which the scale plate, of platinum, is attached. This is graduated from 25.75 to 31.00 inches in twentieths, and a vernier reads to 0.001 inch. The whole barometer, 121 cm long, is mounted on trunions, attached to a board 130 x 20 cm by cast brackets, so that it can be turned about a vertical axis. The thermometer, which has its bulb in the cistern, is not original, being marked "J. Green." The knob for moving the scale is missing. This barometer was transferred from the Smithsonian Astrophysical Observatory in 1956.

Both the Fortin barometer and the movable-scale barometer require one setting and two readings, and also demand that the cistern be kept reasonably clean. Why not simply read the level of the mercury in the tube, providing a fixed, non-adjustable cistern and correcting for the fall of the level in the cistern as that in the tube rises? The easiest way to do this is to make



FIGURE 16

MHT 308,187. Mercury barometer signed "Tonnelot à Paris," in a lacquered brass frame. The tube is 8 mm inside diameter, the cistern about 8 cm; therefore, the silvered scale is graduated in units of 0.99 mm from 590 to 820. There is a vernier reading to 0.05 mm flush with the scale on a sliding sleeve moved by a rack and pinion. The scale is inscribed "Echelle compensée." Overall length 90 cm. Transferred from the Signal Corps in 1923. (Smithsonian photo 61901.)

the scale in contracted units, chosen so that one unit is equal to $A/(A+S)$ standard units, where A is the area of the surface of the mercury in the cistern, and S the internal cross-sectional area of the tube. This procedure, suggested in 1792 by Hugh Hamilton,⁴⁰ became common in British ships and stations after 1850, although barometers with cisterns that are not full during transport are very susceptible to accident. A way of circumventing this difficulty, by having the cistern full of mercury during transport but giving it a predetermined volume when in use, was devised by the Paris instrument maker Tonnelot in the 19th century. The Museum has one of his

⁴⁰ *Royal Irish Academy Transactions*, vol. 5 (1792), pp. 117–27.

barometers (MHT 308,187, figure 16). A cross section of the cistern shows that the mercury is contained between two pieces of boxwood, joined by a flexible leather ring. For transport a screw is raised until the cistern is full; in use, it is lowered until the movable boxwood piece rests on the brass cover, ensuring a well-defined volume.

Of recording mercury barometers, the photographic barograph, first invented by T. B. Jordan⁴¹ and greatly improved in England in the succeeding thirty years, proved one of the most durable and satisfactory. The improvements culminated in the Kew Barograph, which received its final form in 1867.⁴² The instrument is in essence a lantern-slide projector, the barometer tube acting as the slide and the drum covered with photographic paper as the screen. Temperature compensation is provided by a zinc rod which moves a small plate in front of the drum by means of a magnifying lever, producing a variable base line on the record. The Museum has a replica (MHT 319,425, figure 17) of a much simpler model made by a Parisian instrument maker about 1865.⁴³

In the last half of the 19th century the great advances in the application of electricity, and especially of electromagnets, led to the construction of a number of recording barometers with electromechanical servo systems. At the cost of some complication, these instruments were free from the sort of errors produced by friction in barographs derived directly from the wheel barometer or the balance barometer and having continuous registration. Of these electromechanical barographs some⁴⁴ were based on the balance barometer, but most of them on the siphon barometer with a float in the open limb.

⁴¹ *Royal Cornwall Polytechnic Society, Annual Report for 1838*, pp. 184–89.

⁴² *Meteorological Committee Royal Society, Report for 1867*, pp. 40–42.

⁴³ *Catalogue des instruments . . . qui se trouvent et se fabriquent dans les magasins et ateliers de Deleuil . . .* (Paris, rue du Pont-de-Lodi, 6, 1865), p. 179.

⁴⁴ *E.g.*, those of A. Sprung and of C. F. Marvin. For details, see op. cit. (footnote 2), chapter 11.

An early barograph of this sort is in the Museum (MHT 318,284), though incomplete; it is an ingenious and complicated instrument devised by G. W. Hough,⁴⁵ which not only made continuous records of the barometric pressure on two drums revolving at different speeds, but also provided a printed record in figures at hourly intervals, a valuable feature that removes all concern about the expansion or contraction of the paper chart. An earlier version, with only one drum, was described and illustrated in 1866.⁴⁶

Hough's barographs were based on siphon barometers of large bore. In the earlier model a float in the open limb carried a wire, at the top of which was a small horizontal platinum disk. Two platinum contacts, one above and one below the disk, were moved as a unit by a screw which was traversed in the appropriate direction to break the appropriate contact. In the later version the float wire moved one end of a lever, platinum-tipped at the other end. The screw that moved the contacts was geared to a second screw which gave a corresponding but magnified motion to the recording pencils. This version was further modified by Hough's assistant H. L. Foreman,⁴⁷ and as the specimens in the Museum are far from complete, we have reproduced in figure 18 an illustration of Foreman's barograph.⁴⁸

MHT 318,284. Hough's printing barograph, second version, incomplete. The siphon tube is 19 mm in bore. In this instrument the drums are moved by a small windlass that unwinds cords from the drums. The clock that drove this mechanism is missing, as is the float. The type wheels exist, but other parts of the printing mechanism have disappeared. The overall

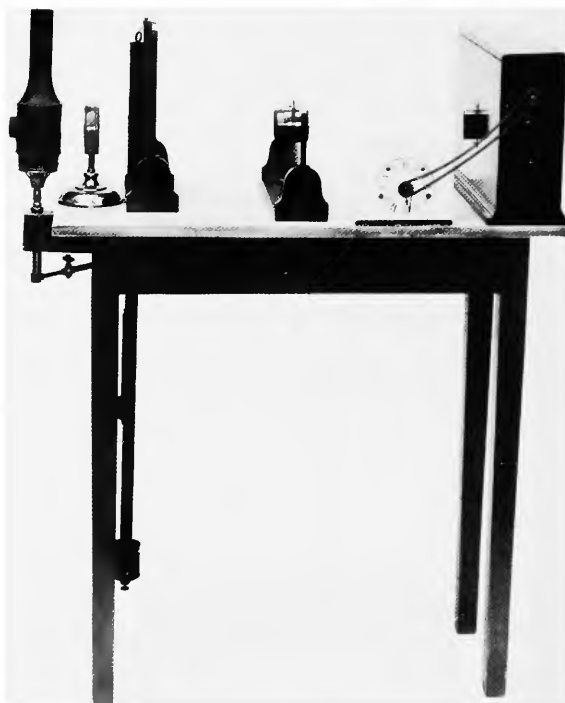

FIGURE 17

MHT 319,425. Reproduction of a photographic barograph made and sold by Jean Adrien Deleuil of Paris in the 19th century. A gas lamp illuminates the upper part of the tube of a barometer from behind. This is imaged by a lens system on to a photographic plate, moved horizontally by a clock. It is all mounted on a table 81 x 40 cm x 81 cm high. The box holding the sensitive plate is 40 x 27 x 10 cm. The total height of the instrument is 110 cm. Made by L. C. Eichner, 1961. (Smithsonian photo 61909-C.)

dimensions of the wooden frame are: 191 cm high, 107 cm wide, and 62 cm deep. There is a glazed case to enclose the upper part of the instrument. Presented in 1960 by Northwestern University, Evanston, Illinois.

The Museum also has the greater part of a similar barograph which seems not to have had the printing mechanism (MHT 317,417), and a

⁴⁵ *Annals of the Dudley Observatory, Albany, N.Y.*, vol. 2 (1871), p. xxiv.

⁴⁶ *American Journal of Science*, 2d ser., vol. 41 (1866), pp. 43-58.

⁴⁷ *Op. cit.* (footnote 36), pp. 26-29.

⁴⁸ *Ibid.*, p. 27.

fragment (MHT 314,525) with a different mechanism for moving the pens.

MHT 317,417. A mercury barograph of the type designed by G. W. Hough. Incomplete, only one of the two drums exists. It appears that the drum is moved in small steps by means of a cam, ratchet, and pawl. The motion of the pen is controlled by a lever by two electric switches operated through a lever in the open arm of a siphon barometer. Two electromagnets control a clockwork and a reversing gear which drives the pen, the contact system, and the lever in such a direction as to restore the contact on the lever to a position in which it does not touch either of two other contacts. The drive is by means of a screw that feeds vertically through a constrained nut rotated in either direction by the clockwork. The instrument, which measures 76 cm x 31 cm x 92 cm high, is provided with a glazed wooden case 127 x 81 x 40 cm. Presented in 1960 by Dudley Observatory, Albany, New York.

MHT '314,525. Part of the clockwork and one drum of a barograph which evidently resembled that of H. L. Foreman, and may have been designed by him. It differs fundamentally in that the pens are operated by a cord or chain (missing) passing over a pulley, and not by a lead screw and nut. The surviving part is 40 cm high x 30 x 21 cm, and apart from the drum, which is of wood, is mainly constructed of brass. Transferred from the Weather Bureau in 1954.

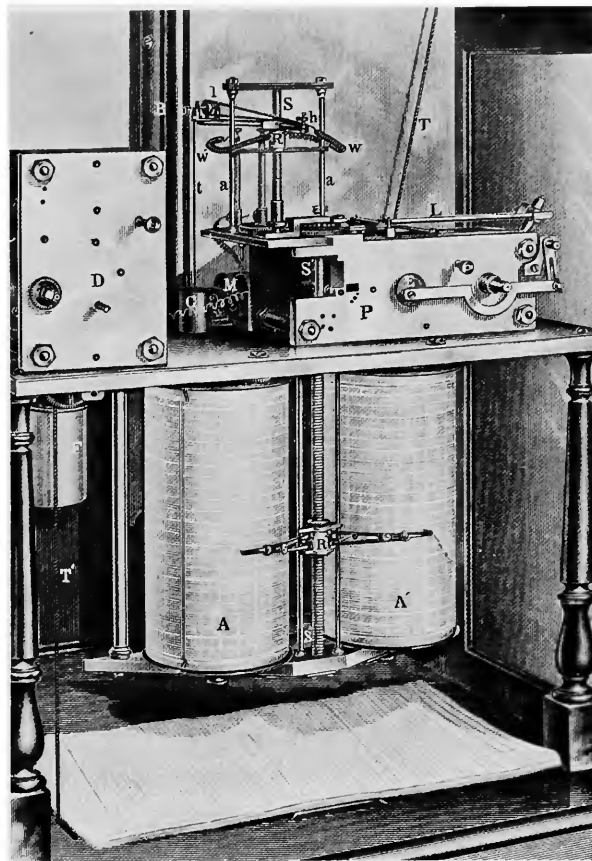

FIGURE 18

Diagram of Foreman's barograph. (U.S. Weather Bureau Circular F, 1894, page 27; Smithsonian photo 63886.)

Aneroid Barometers and Barographs

The barometers that we have been considering are all variants of the original apparatus of Torricelli, balancing the weight of a column of the atmosphere against that of a column of mercury. The remaining barometers that we must discuss are of a quite different sort, measuring atmospheric pressure by the deformation of some system of metallic or other solid bodies. No liquid is involved, and Lucien Vidie, who made the first practical barometers of this sort, called them aneroid barometers, from the Greek words *a*, without, and *neros*, liquid.

Suggestions for barometers of this kind had been made by G. W. Leibnitz in 1698, I. E.

Zeihler in 1763, and N. J. Conté in 1798,⁴⁹ but the technical means were not available to any of them. It was left to Vidie to succeed in making satisfactory metallic barometers in the face of erroneous ideas held by the scientific world about the properties of metals. This was in 1843, and in 1844 he took out his basic patents.⁵⁰ His first barometer had a corrugated diaphragm supported by 33 helical springs in a strong evacuated brass box. A cup was soldered into the center of the diaphragm, and a nut in this cup engaged a

⁴⁹ For details see op. cit. (footnote 2), pp. 398-400.

⁵⁰ British Patent 10,157 (1844); French Patent 12,473 (1844). In 1846 he took out a U.S. Patent 4,702.



FIGURE 19

MHT 308,166. Aneroid barometer with Spanish markings. It is graduated from 68 to 80 cm and from 27.4 to 31.7 inches of mercury. It is of the type having the external spring in the form of a helix, most of the mechanism being visible under a glass plate. It is in a brass case 15 cm in diameter and 5.5 cm thick. Presented in 1923 by Taylor Instrument Companies, Rochester, New York. (Smithsonian photo 61902-A.)

steep-threaded screw to which the pointer was attached. A hairspring took up backlash, and a bimetal provided temperature compensation.

By about 1847 the instrument had been greatly simplified by the use of a flat double-sided vacuum chamber and an external spring, at that date helical, as in MHT 308,166 shown in figure 19. The more familiar flat spring, as in figure 20, formed part of a Vidie patent⁵¹ as early as 1845, and this patent also covered various devices for temperature compensation. Aneroid

barometers made at about this time seem to have been compensated for temperature by leaving a little air in the chamber, but twenty years later it was more common to make the first lever bimetallic, as in figure 20, taken from part of MHT 323,503, and the great majority of aneroid barometers made since that time have had a mechanism of this sort. The pattern was set by the Paris firm of Naudet & Cie, who called their aneroids by the curious name "Holosteric barometer," as in a specimen (MHT 230,002) in the Museum (figure 21).

Aneroid barometers tend to be given to museums in large numbers, and the Museum of

⁵¹ French Patent 1,149 of 1845.

FIGURE 20

Assembled mechanism of aneroid barometer with new hand supplied. MHT 323,503 has a panel 51 x 51 cm, with a labeled display of the parts of an ordinary aneroid barometer, the assembled mechanism, and the completed instrument, which is of the type with a curved spring and bimetallic compensation. Marked "Parts used in construction of Tycos Stormoguide," and "Taylor Instrument Co. Rochester, N.Y. 1922." (Smithsonian photo 61911-A).

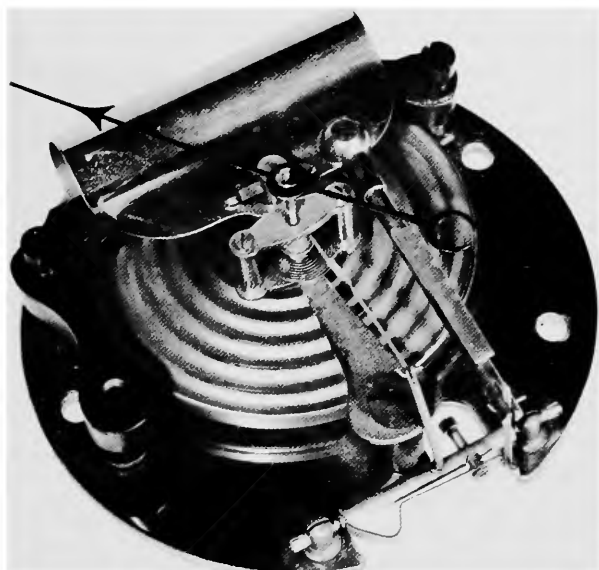
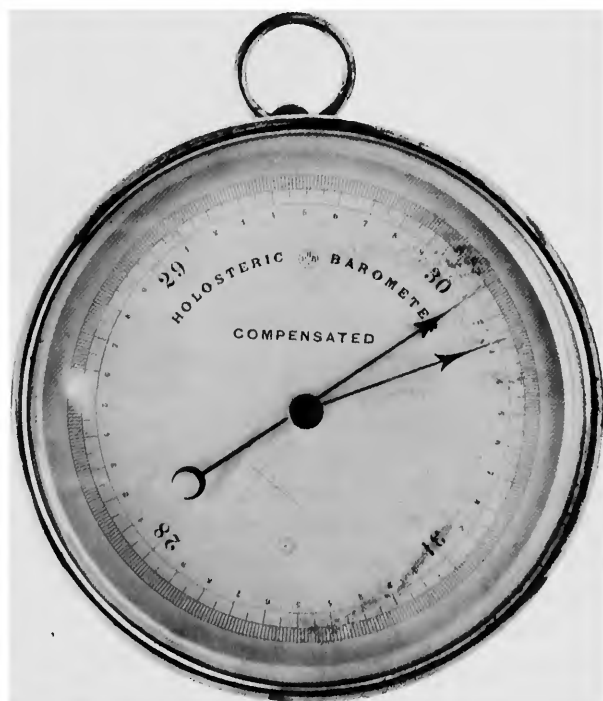

FIGURE 21

MHT 230,002. Aneroid barometer in brass case 12.5 cm in diameter and 5 cm thick, with glass front. On the silvered metal dial is marked "Holo-steric Barometer Compensated" and the trademark of Naudet & Cie with the letters H, P, B, and N arranged as a cross within a circle. The scale is graduated in hundredths of an inch of mercury from 28 to 31 inches. (The aneroid is graduated in pressure units: inches of mercury, millimeters of mercury, or millibars—kilodynes per square centimeter; therefore, it would be incorrect to say than an aneroid is "graduated in inches.") The pointer is blued, and a brass pointer operated by an external knob is provided as a reminder of the reading at the previous observation. On the back is engraved "U.S. Signal Service 1101." Deposited by the Weather Bureau in 1904. (Smithsonian photo 61831-B.)



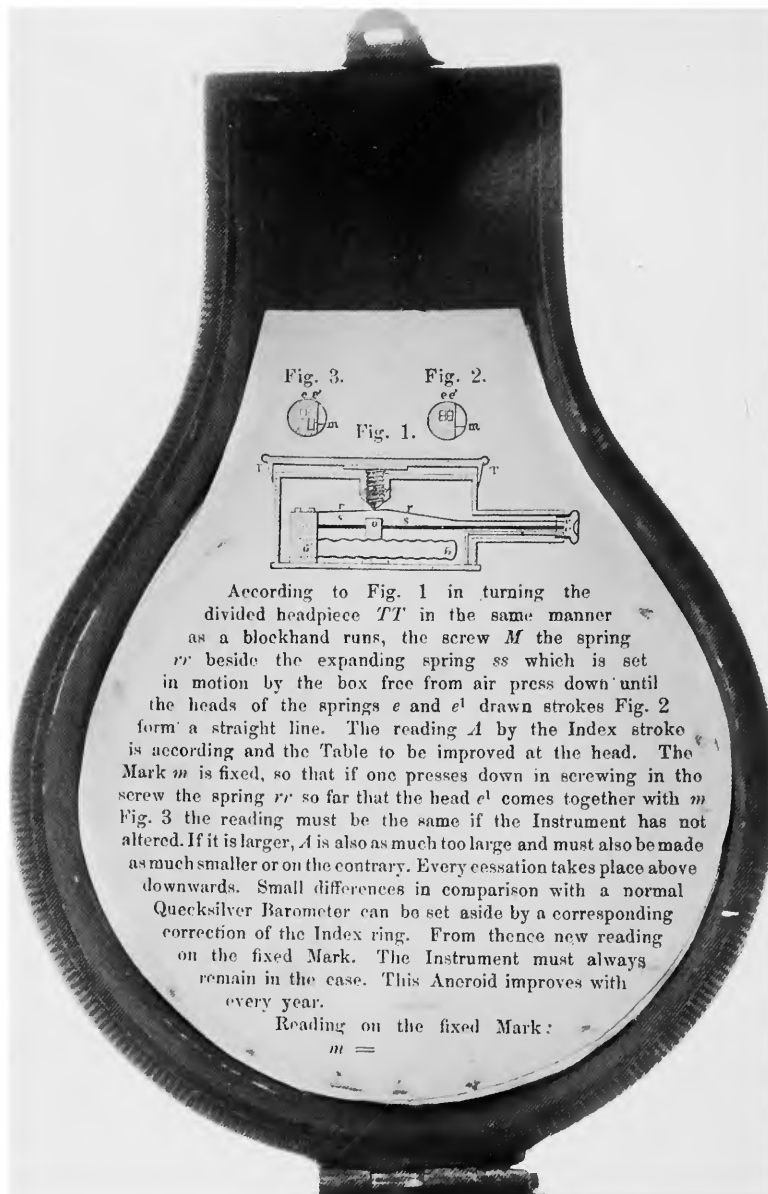

FIGURE 22
 Cross section of Goldschmid's aneroid. (Smithsonian photo 61831-D.)

History and Technology is no exception to the rule. Other specimens are listed at the end of this chapter; but we must mention the provision of an altitude scale in addition to the scale of barometric pressure, a feature first suggested to Negretti and Zambra by the Astronomer Royal,

Professor (later Sir George) Airy (1801-92), who provided a calculation based on an isothermal atmosphere at 50° F.⁵² These were often made to

⁵² Negretti & Zambra, *A Treatise on Meteorological Instruments* (London, 1864), p. 55.

be carried in the pocket like a watch, as in MHT 247,924, and were sold, but probably not made, by James Green.

MHT 247,924. Aneroid barometer with scales of pressure and height, in plated case 7 cm diameter x 3.2 cm thick. Graduated from 31 to 15 inches and 0 to 20,000 feet. Marked on the silvered face "James Green New York. Compensated" and "U.S. G. S. N° 60." On the back, "19." A milled edge can be used to position a pointer. Presented in 1907 by the U.S. Geological Survey.

At the end of the 19th century many aneroids of very high quality were made for the use of surveyors; the Museum has an excellent example (MHT 308,172).

MHT 308,172. A high-quality aneroid in a plated brass case 12.6 cm diameter x 6 cm thick, with a beveled plate-glass front. It is graduated from 31 to 24.8 inches of mercury in fiftieths, and from 0 feet (at 31 inches) to 6,400 in 10-foot divisions, with a vernier reading to one foot, set by an external milled knob 1.9 cm in diameter. A magnifier on a post can be revolved around the rim of the instrument for reading the vernier. On the front panel is engraved "Surveying Aneroid Compensated for temperature Short & Mason London Tycos Made in England." This instrument was sensitive to a change of height of 1 foot in 1966. Presented in 1923 by Taylor Instrument Companies, Rochester, New York.

Because the pressure varies at a given station, it was thought to be a good idea to make the scale of altitudes movable with respect to the pressure scale. The Museum has several examples of this construction, of which the pocket aneroid, MHT 247,927, is typical. But the pressure does not vary uniformly with altitude, but exponentially, and this procedure is of limited usefulness unless the altitude scale can be made linear.

MHT 247,927. Aneroid barometer with movable height scale, in a gilt brass case, 6.8 cm in diameter and 2.4 cm thick, watch-shaped, with a plate-glass front. The scale of heights, 0 to 10,000 feet in units of 50 feet, can be moved by means of a milled rim in relation to the scale of pressure, graduated from 31 to 21 inches

of mercury in $\frac{1}{20}$ -inch divisions. The scale has the words "Rain," "Change," and "Fair" at 28.5, 29.5, and 30.5 inches respectively, and is marked "Compensated Made in England." Presented in 1907 by the U.S. Geological Survey.

This was done during the war of 1914-18 by careful design of the linkage between the aneroid chamber and the pointer; ⁵³ MHT 308,169 is an instrument of this sort, made in 1919.

MHT 308,169. Aneroid barometer with movable altitude scale, in a plated case 7.6 cm in diameter and 3.6 cm high. Graduated from 31 to 25.8 inches and 0 to 5,000 feet; the altitude scale has been made linear, and in consequence the pressure scale is not. The altitude scale can be rotated by means of a milled ring so that the height of the starting point can be set to the current pressure. On the silvered face appears "Compensated for temperature Tycos Rochester, N.Y., U.S.A." Presented in 1923 by Taylor Instrument Companies, Rochester, New York.

A considerable improvement in stability, at the expense of the necessity of setting the instrument before reading it, was made about 1857 by instrument-maker J. Goldschmid of Zurich. In his instrument, the capsule is under no constraints except the resistance of the spring. There are at least two forms of this instrument, both represented in the Museum. The action of the simpler of the two may be described by reference to the diagram pasted in the lid of the leather case of specimen MHT 314,545, shown in figure 22, in which *bb* is the vacuum chamber, *ss* the tension spring, and *rr* a second spring pushed down by a micrometer screw operated by the graduated head *TT*. The ends of the two springs *ss* and *rr* carry fiducial marks, as shown in figures 2 and 3 at *e* and *e'* respectively. To read the instrument, the head *TT* is turned until the marks *e* and *e'* coincide, and the pressure read on the scale engraved on the rim. The mark *m* is a fixed reference mark, to which *e'* can be brought in order to determine whether the

⁵³ Glazebrook, *Dictionary of Applied Physics* (London, 1923), vol. 3, pp. 180-83.

FIGURE 23

MHT 314,545. Aneroid barometer, Goldschmid type, made by Hottinger & Co., Zurich. The plated brass case is 9 cm in diameter and 6 cm thick, the tubes containing the indexes and the thermometer are each 0.9 cm in diameter and 4.5 cm long. The thermometer is graduated at 2° intervals from 40 to 120° F. The index of the pressure scale is adjustable over a range of about 0.25 inch in pressure; the scale itself is graduated from 28 to 31 inches of mercury in 0.05-inch divisions. The circular top of the barometer has a glass bezel covering a paper label on which is printed "Ship-Barometer N° 116," "Hottinger & Co. Zurich," and correction tables. There is a shaped case covered with black leather. Transferred from the Weather Bureau in 1954. (Smithsonian photo 61831-C.)

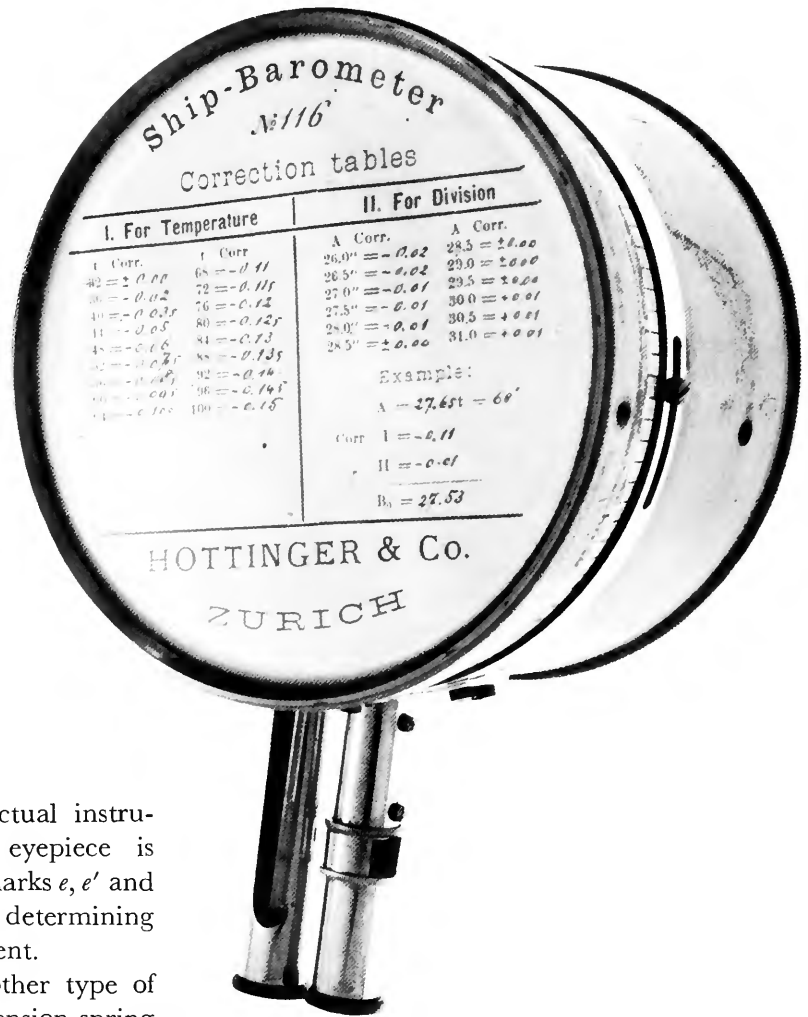

calibration has changed. In the actual instrument, shown in figure 23, an eyepiece is provided for the observation of the marks *e*, *e'* and *m*, and a thermometer is installed for determining the temperature inside the instrument.

Hottinger & Co. also made another type of Goldschmid aneroid in which the tension spring is of the familiar curved form, as shown in the exploded view, figure 24,⁵⁴ eliminating the eyepiece tube. The Museum possesses one of these (MHT 314,546).

MHT 314,546. Goldschmid-type aneroid barometer, 8 cm in diameter and 5 cm thick. In this instrument, intended for mountain use, the whole number of inches of mercury is read from a small scale near the eyepiece, the movable pointer being set to the nearest one of these, and the hundredths read on the large scale on the cap. Under the glass top is printed "Aneroid Barometer No. 3241," "Hottinger & Cie. Zurich," and correction tables. Transferred from the Weather Bureau in 1954.

American ingenuity has not contributed greatly to the design of meteorological aneroids,⁵⁵ but the Museum has one (MHT 313,693) that was built under U.S. Patent 24,635 dated 14 June 1859, issued to Victor Beaumont. The patent covered the use of multiple elastic chambers and was really concerned with steam gauges, a concern that is reflected in the general appearance of the instrument shown in figure 25.

Naturally there was an impetus to make a recording instrument out of the aneroid barometer. The first successful solution to this problem seems to have been an instrument made in

⁵⁴ Op. cit. (footnote 36), p. 20.

⁵⁵ Aircraft altimeters are, of course, quite another matter.

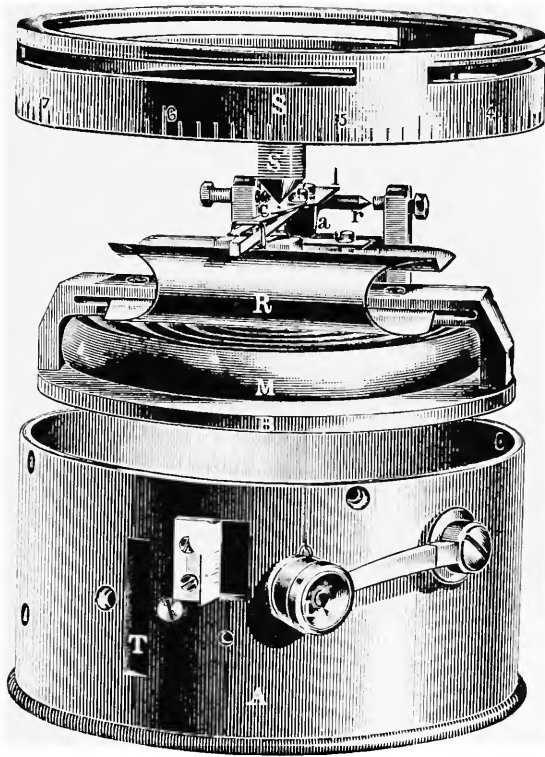

FIGURE 24

Goldschmid's aneroid barometer, later form, exploded view. (From U.S. Weather Bureau Circular F, 1894, page 20; Smithsonian photo 63885.)

or about 1867 and exhibited at the Paris International Exhibition.⁵⁶ This used an external leaf spring over the three aneroid capsules, and was compensated for temperature by leaving some air in them.⁵⁷ After about 1885, however, it became standard practice to use a pair of leaf springs in each capsule, as was done by the firm of Richard Frères in their barograph, one of their remarkably complete line of simple and effective recording instruments which revolutionized meteorological observation in the last

⁵⁶ See R. Radau, *Repert. für phys. Techn.*, vol. 3 (1867), pp. 330–31.

⁵⁷ *Annuaire de l'Obs. de Mont-Souris pour l'an 1878*, pp. 256–57.



FIGURE 25

MHT 313,693. An aneroid barometer in a cylindrical brass case 10.5 cm in diameter and 5.4 cm deep, with a scale covering an arc of less than 90 degrees and graduated in tenths of an inch from 28 to 31 inches of mercury. The scale plate is marked "Beaumont's Barometer 175 Center Str^t. New York Patented June 14th 1859." (Smithsonian photo 61831-A.)

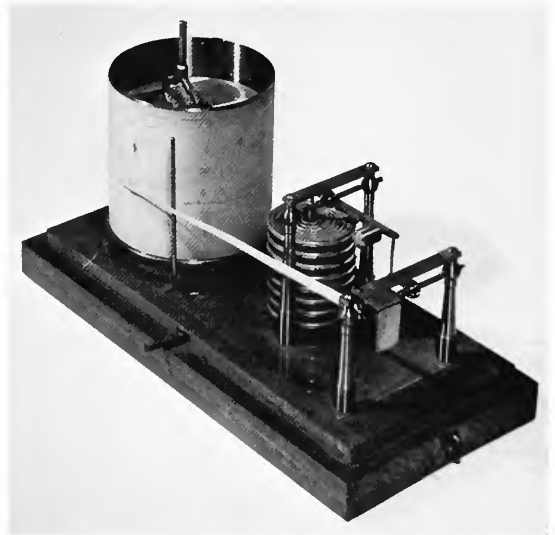

FIGURE 26

Standard Richard barograph (MHT 252,981). (Smithsonian photo 46740-C.)

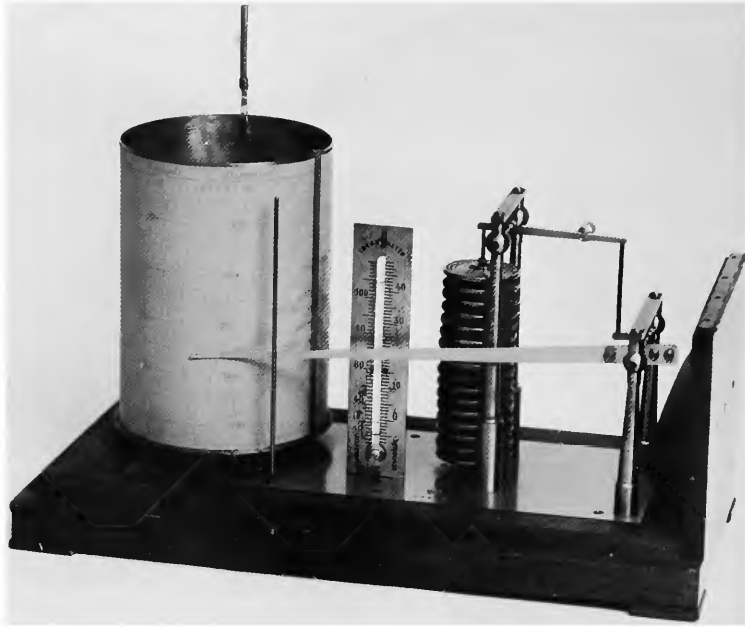

FIGURE 27

MHT 308,190. Large aneroid barograph by Richard Frères, giving a record magnified three times on a chart carried by a drum 12.7 cm in diameter and 17.3 cm high. There are 16 aneroid chambers in series, 4.5 cm in diameter, with internal springs and probably compensated for temperature by leaving some air in one or more of them. The motion of the top of this pile of chambers is transmitted to the

pen, which is on a 27-cm arm, by two levers and a link. A thermometer in Fahrenheit and centigrade degrees is attached to the brass base. The entire instrument was in a mahogany case 40 x 19 x about 26 cm, of which the top is now missing. On the baseplate is the Richard Frères trademark and the number 82094. Transferred from the Signal Corps in 1923. (Smithsonian photo 61830-C.)

years of the 19th century.⁵⁸ The main innovations introduced by this enterprising firm were the drum with which an integral clock revolves, the simple adjustments for scale and zero, the spring clip for the chart paper, and the familiar recording pen in the form of a triangular pyramid, split at the tip.⁵⁹

⁵⁸ *Notice sur les instruments construits par Richard Frères, comprenant le rapport de M. le Colonel Sébert à la Société d'Encouragement pour l'Industrie Nationale, et l'exposé des perfectionnements et applications nouvelles* (Paris, 1889).

⁵⁹ Illustrated, and two of them claimed, in U.S. Patent 334,613 issued to Jules Richard on 19 January 1886.

The Museum has several of the standard Richard barographs of the period, of which one (MHT 252,981) is illustrated in figure 26.

MHT 252,981. Transferred from the U.S. Geological Survey in 1909.

MHT 261,255. Transferred from the Department of the Interior in 1910.

MHT 314,532. Transferred from the Weather Bureau in 1954.

Three aneroid barographs by Richard Frères, Paris, mechanically identical, but with slight variations in the construction of their wooden glass-fronted cases, 28 x 13 x 16 cm. They bear the serial numbers 673, 1435, and 8772 respectively, on their brass baseplates. Each has eight

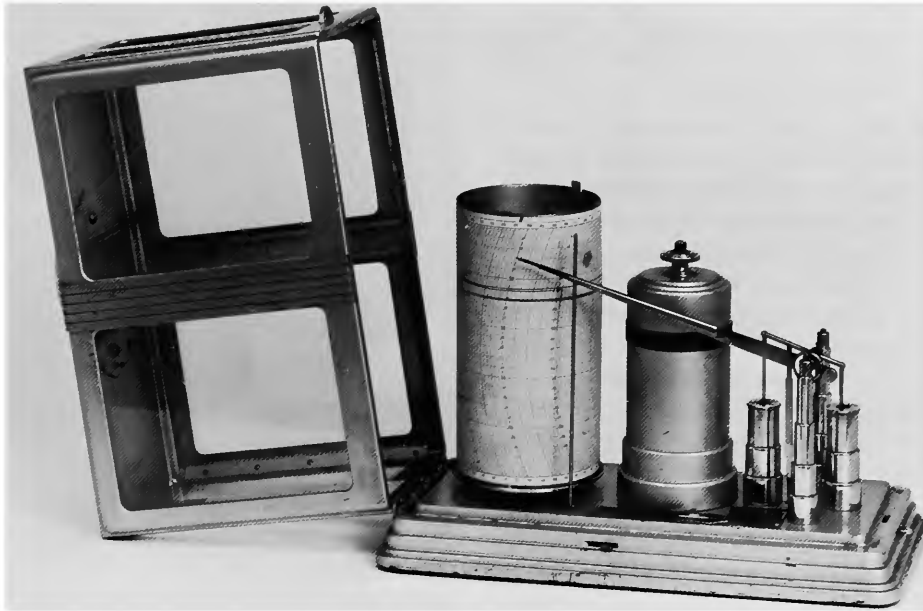

FIGURE 28

MHT 316,288. Friez aneroid barograph with a scale magnification of 2.5, and a drum 9.2 cm in diameter and 17.5 cm high, revolved once in four days by an internal clock. The sensitive element is a metal bellows, and there are two dash pots for damping. Marked "Signal Corps

U.S. Army Barograph ML-3-A Serial N° 124 Order N° 1316-WF-42 Made by Julien P. Friez & Sons Baltimore Maryland U.S. Patent 2,165,744." In glazed aluminum case 33 x 17 x 24 cm. Provenance unrecorded. (Smithsonian photo 61908-D.)

aneroid chambers in series, the deflection of which is communicated to a pen arm, 18 cm long, by two levers and one link. The clock and drum are Richard Frères standard, the drum 9.2 cm diameter x 9.2 cm high. On number 252,981 there is a weekly chart graduated in inches and tenths from 28 to 31, with the names of the days in English.

On number 314,532 a nameplate notes that J. Glaenzer & Co. of 80 Chambers Street, New York, are sole agents for the United States, and refers to Patent No. 334,613.

The Museum also has a large model (MHT 308,190, figure 27) with 16 aneroid chambers in series, which gives a record magnified 3 times in mercury units.

It is necessary to emphasize that in bringing out these simple and relatively inexpensive in-

struments, Richard Frères were ahead of their time, for this was the era of large and costly barographs, the era when it was thought that the possible accuracy of meteorological observations was limited by that of the instruments, instead of by the random spatial and temporal fluctuations of the atmosphere itself, and by the imperfections of exposures.⁶⁰ Indeed, Cleveland Abbe was just writing 36 pages on the corrections to the mercury thermometer in his great *Treatise on meteorological apparatus and methods*.⁶¹

⁶⁰ These ideas are developed by W. E. K. Middleton in *Quarterly Journal Royal Meteorological Society*, vol. 72 (1946), pp. 32-50.

⁶¹ U.S. War Department, *Annual Report of the Chief Signal Officer . . . for 1887*, Appendix 46 (Washington, 1888), pp. 41-77.

Aneroid barographs changed little in essentials until about 1920, when a barograph using a metal bellows (MHT 308,189) was made by the firm of Julien Friez at Baltimore.

MHT 308,189. Aneroid barograph marked "Julien P. Friez & Sons," the sensitive element being a bellows 5 cm in diameter and 4.3 cm high, with 13 corrugations. The zero adjustment is by a lever beneath the baseplate, moved by a milled knob above it. There is a hooked link so that the lever system may be disengaged from the bellows for transport. The mechanism is on an iron base 28 x 13 cm, which formed part of a glazed case, now missing. Pen radius, 17 cm. Transferred from the Signal Corps in 1923.

In 1928 a larger instrument of this sort with magnification of 3 was put on the market, and in 1939 William Boettinger patented⁶² an ingenious use of a bimetal for the shaft of the first lever of a barograph. This bends with change of temperature so as to alter the ratio of the two arms of the lever. It is used in addition to the device of leaving some gas in the bellows, which compensates only at one particular value of atmospheric pressure. The Museum has one of these instruments (MHT 316,288), shown in figure 28.

Before the Richard firm had had their excellent idea, there had been several attempts to make aneroid barographs. Possibly M. Hipp of Neuchâtel was unduly impressed by the explosion in the use of electromagnets, for in 1871 he designed the instrument (MHT 314,544) shown in figure 29.⁶³ Although the large aneroid chambers and strong spring must have plenty of control, Hipp felt it desirable to use discontinuous recording, and made the electromagnet bring a bar down

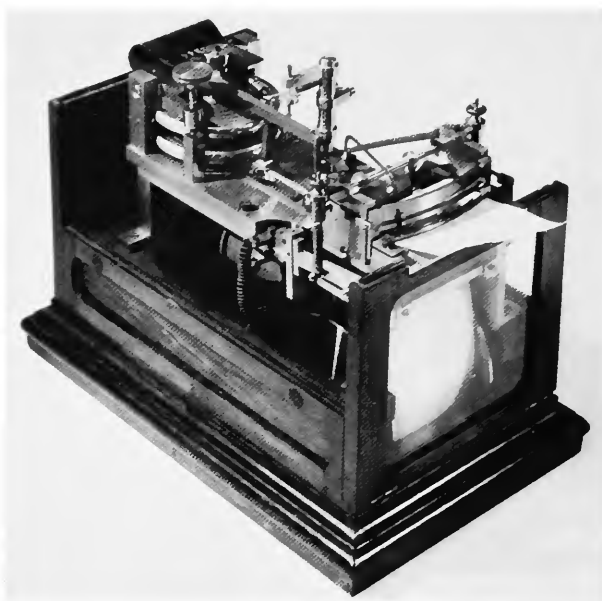

FIGURE 29

MHT 314,544. An aneroid barograph marked "M Hipp. Neuchâtel Suisse 7243." Two large aneroid chambers move an arm which records discontinuously on a band of paper 7 cm wide. The instrument is 30 x 18 x 21 cm overall. A glass cover is missing. Transferred from the Weather Bureau in 1954. (Smithsonian photo 46740-D.)

on the pointer, printing a point every 10 minutes on a strip chart. Immediately after this, the chart was advanced by a ratchet and pawl.

It will be seen that the Museum of History and Technology has specimens that range over most of the history of the barometer, including several of the most important American contributions to its development.

⁶² U.S. Patent 2,165,744 issued 11 July 1939.

⁶³ *Zeits. österr. Meteorol. Ges.*, vol. 6 (1871), p. 104.

Instruments not Referred to in the Text

Mercury Barometers

The first four of the following mercury barometers, which are shown in figure 1 on page 2, were all made by the New York firm of Benjamin Pike & Sons, probably in the second quarter of the 19th century. They form part of an exhibit that reconstructs the New York shop of the Pike firm.

316,739. Mercury barometer in a plain but elegant veneered mahogany case. This has a boxwood cistern, with a leather bottom adjustable by means of a brass screw working against a brass plate. The cistern has a cover, but the remainder of the tube is exposed; its upper part, the silvered-brass scale plate, and the thermometer being covered by a glazed frame 12 x 22 cm with a semicircular top. This frame has to be swung aside on its hinges in order to set the simple flat-topped pointer and vernier. The scale is graduated from 27 to 31 inches in tenths, and the vernier reads to 0.01 inch. There are the usual weather signs, "Rain," "Change," "Fair." The thermometer is graduated from -20 to $+114^{\circ}$ F. The scale plate is engraved "Benj Pike & Son New York." Overall length, 95 cm. Received in 1959.

319,958. Wheel barometer in a plain-shaped oak case, displaying from top to bottom a gut hygroscope of the usual form, 5 cm in diameter, a Fahrenheit spirit thermometer graduated from 6 to 112 degrees in 2-degree steps, the barometer dial 20 cm in diameter, and a bubble level set in a brass plate inscribed "B. Pike & Sons 518 Broadway New York." The dial is graduated from 28 to 31 inches, with the words "Storm," "Much Rain," "Rain," "Change," "Fair," "Set Fair," and "Very Dry." Besides the blued pointer of the barometer there is a brass setting pointer, but the knob that moved it is now missing. Overall length, 94 cm. Presented in 1961 by Mr. Silvio A. Bedini of Washington, D.C.

323,000. Plain, household mercury barometer with a boxwood cistern closed at the bottom by a leather diaphragm and provided with a brass screw that pushed this up for transport. The oak frame covers the cistern, and carries a little carving near the top and bottom. The thick tube, 1.2 cm outside diameter and

about 0.3 cm inside, is nearly all visible. The ivory scale plate is graduated from 27 to 31 inches in tenths, and there is a vernier reading to hundredths. The scale plate is inscribed "B. Pike & Sons 518 Broadway New York." At the left-hand side of the tube, opposite the scale, is a thermometer graduated from 0 to 125° F, and -14 to $+42^{\circ}$ R. The barometer scale has the usual weather signs: "Stormy," "Rain," "Change," and "Fair." Overall length, 95 cm. Presented in 1963 by the Physics Department of Wabash College, Crawfordsville, Indiana.

326,144. "Pike's best and most elegant barometer." A mercury barometer in a very elaborately carved oak case, with a bas-relief portrait of George Washington on the cistern cover. In a sloping frame of ivory, there are two scales graduated from 27 to 31 inches in tenths, with separate verniers reading to 0.01 inch. One scale is superscribed "Yesterday" and the other "Today." On the upper part of the ivory is engraved "Benjⁿ Pike Jun^r 294, Broadway New York." There is a thermometer in Fahrenheit degrees with a cylindrical bulb, and graduated from -43 to $+159$. One of the two ivory knobs for moving the verniers is missing, as is a knob at the bottom of the barometer for adjusting the volume of the cistern when the barometer was to be transported. Overall dimensions, 107 x 23 x 9 cm. Received in 1965.

308,174. Mercury barometer with cistern of the Fortin type, with means of closing the end of the tube for transport. Similar to MHT 325,999 shown in figure 15. Presented in 1923 by Taylor Instrument Companies, Rochester, New York.

319,957. Mercury barometer, Fortin-type, 99 cm long. Incomplete. Provenance unknown, but marked "Educational Depository, U.C."

Mercury Barographs

316,819. Small portion of the mechanical parts of Foreman's barograph, with one drum, and parts of a protecting glazed-metal case, 43 cm high x 25 cm x 23 cm. Transferred in 1959 from the Weather Bureau.

318,283. Portions of a Hough barograph, built on a wooden table 108 x 35 cm x 97 cm high. The siphon

tube, 1.3 cm in bore, remains, but only a little of the mechanism, including a weight-driven clockwork. The instrument appears to have recorded on a chart fixed to a vertical wooden board 42 x 23 cm, which is drawn sideways on a rail. Presented in 1960 by Northwestern University, Evanston, Illinois.

Aneroid Barometers

205,532. Decorative assembly for use on a desk, comprising an aneroid barometer, clock, compass, and thermometer. The barometer has weather indications in Spanish on the dial. It is said to have been in the house where the Filipino leader Aguinaldo was captured, but is of no scientific interest.

247,925. Aneroid barometer similar to MHT 247,924, described on page 27, but graduated from 31 to 20 inches of mercury and 0 to 12,000 feet of altitude. The scale plate is marked "J. & H. J. Green. New York. Ja^a. Pitkin. Maker London. Compensated" and "U.S. G.S. N^o 181." Diameter, 7 cm. Transferred from the U.S. Geological Survey in 1907.

247,926. Aneroid barometer with movable height scale, in a gilt brass case, 6.8 cm in diameter and 2.4 cm thick, with a milled ring to rotate the height scale. Pointer missing. Dial marked "Compensated J. W. Queen & C^o., Philadelphia" and "U.S. G.S. N^o 197. Transferred from the U.S. Geological Survey in 1907.

247,928. Aneroid barometer in a brass case 4.8 cm in diameter and 1.9 cm thick. Glass front, mechanism partly exposed. Scales of pressure and height. "N^o 21 U.S. G.S." marked on the back. It is in a mahogany box 7.3 x 7.3 x 3.9 cm, marked "A Lietz & Co., Opticians, San Francisco." Transferred from the U.S. Geological Survey in 1907.

261,256. Aneroid barometer in brass case 14 cm in diameter and 6 cm thick, marked "Baromètre de Precision Pour stations météorologiques Alvergnaat F^{res} 10, R. de la Sorbonne". Glass front missing, pointer damaged. Transferred from the Department of the Interior in 1910.

261,257. Aneroid barometer in brass case 10.7 cm in diameter and 4.8 cm thick. Brass setting pointer. It is graduated from 68 to 80 (cm). Transferred from the Department of the Interior in 1910.

307,962. Aneroid barometer, thermometer, and clock on walnut base. Presented in 1923 by Dr. and Mrs. M. L. Turner of Berwyn, Maryland.

308,167. The mechanism of a large aneroid barometer, mounted on an iron plate 13.8 cm in diameter and 0.35 cm thick. The aneroid chamber is 7.9 cm in diameter. One link has a means of changing the magnification. "Taylor Rochester" is marked in white capital letters on the baseplate. Presented in 1923 by the Taylor Instrument Companies, Rochester, New York.

308,170. Aneroid barometer, "Stormoguide," in brass case 13 cm in diameter and 6 cm thick, with an elementary treatise on single-observer forecasting on the dial. There is a dial at the back for setting the instrument to correspond with the height above sea level at which it is installed. Presented in 1923 by the Taylor Instrument Companies, Rochester, New York.

308,186. Aneroid barometer in a brass case 12.5 cm in diameter and 5 cm thick, marked on the dial "Baromètre Holostérique Compensé Naudet & Cie Paris Service Météorologique." The dial is graduated from 65 to 80 cm of mercury. There is a brass setting pointer. Transferred from the Signal Corps, U.S. Army, in 1923.

313,415. Aneroid barometer in a brass case 13 cm in diameter and 6 cm thick. Glass cracked. On the dial "U.S. Navy. Made by Taylor Instrument Companies, Rochester, N.Y. Tycos." Transferred from the Department of the Navy in 1950.

314,530. Watch-shaped aneroid barometer 7.0 cm in diameter and 2.3 cm thick, graduated from 28 to 31 inches of mercury in fiftieths. On the dial is marked "Compensated No. 1016. U.S. Weather Bureau," and "Tycos," with the monogram of Short & Mason, London. A pointer can be set by turning a milled ring. Transferred from the Weather Bureau in 1954.

314,547. Aneroid barometer in a brass case 14 cm in diameter and 5 cm thick, with a plate-glass front and a silvered dial. This is graduated from 17 to 22 inches of mercury, in tenths, and also bears the figures "10,000, 11,000 . . . 15,000" but no actual height scale. Marked "L. Casella Maker to the Admiralty & Ordnance. London. Compensated 2634 'For Issue' N^o 21." Transferred from the Weather Bureau in 1954.

314,548. Aneroid barometer in brass case 12 cm in diameter and 4 cm thick, with a glass front. Graduated from 22 to 31 inches of mercury in tenths. Bears the number "1634" but no maker's name. Transferred from the Weather Bureau in 1954.

314,549. Aneroid barometer of the Goldschmid type, similar in general appearance to MHT 314,545 (figure 22) except in its dimensions. It is in a nickel-plated brass case 4.2 cm in diameter and 2.9 cm thick. The eyepiece tube and the thermometer project about 3 cm. It has a scale in divisions of 5 inches of mercury in the eyepiece tube, the cap being graduated in units of 0.02 inches. It is marked "Hottinger & Co. Zurich No. 1132" on the cap.

314,550. Aneroid barometer with height scale, in a plated case 5.5 cm in diameter and 2.2 cm thick, with a glass front. The zero of the height scale (−1,000 to +12,000 feet) is opposite 29.5 inches of mercury on the scale of pressure. The dial is marked "Semmons Oculist Optician 687, Broadway New York." The instrument is in a leather case with a thermometer and a small reading glass. Transferred from the Weather Bureau in 1954.

314,551. Pocket aneroid barometer, 4.8 cm in diameter and 1.8 cm thick, with a gilt brass case, a glass front, and a silvered scale graduated from 25 to 31 inches of mercury in twentieths, marked "R. & J. Beck's Farmer's Barometer 31 Cornhill London 582." The instrument is marked on the back "Signal Service U.S. Army No. 17." Transferred from the Weather Bureau in 1954.

316,274. Aneroid barometer for use in aircraft. In a plated case 13 cm in diameter and 8 cm thick, this instrument has a scale graduated from 1100 to 50 millibars in 2 mb divisions, and marked "R. Fuess Berlin-Steglitz 195153 D.R.P. mb." The case has 3 shock cords attached 120 degrees apart. Transferred from the Weather Bureau in 1959.

326,964. A pocket aneroid barometer for mountain use, in a brass case 5 cm in diameter and 2 cm thick. The silvered scale is graduated in cm of mercury and in meters of altitude from −500 to +1500, and is marked "L. Casella Maker to the Admiralty & Ordnance London Compensated 2311." Presented in 1965 by Mr. Philip Squire Sampson of Arlington, Virginia.

Aneroid Barographs

308,171. A conventional aneroid barograph, in a mahogany case glazed on the front and ends and measuring 31 x 16 x 18 cm. The drum, which contains the clock, bears a chart graduated from 28 to 31 inches of mercury. On the frame of the instrument is marked "Tycos Stormograph Reg^d. U.S. Pat. Off. Short & Mason London Made in England." The base is labeled "Taylor Instrument Companies Rochester, N.Y., U.S.A." by whom it was presented in 1923.

314,531. Aneroid barograph by Richard Frères, in essentials similar to MHT 252,981 (figure 26), but with a brass base 30 x 16 cm and a glazed, brass-framed cover. It has eight aneroid chambers with internal springs. The baseplate is marked "Richard Frères Constructeurs Brevetés Paris," and "43974 Y." Transferred from the Weather Bureau in 1954.

317,485. Conventional aneroid barograph, similar to 308,171 above except for the mahogany case. The clock in the drum is marked "Pat. 3715. 02." The instrument itself is marked with the trademark of Short & Mason and "London Tycos." Overall dimensions, 36 x 20 x 17 cm. Transferred from the Weather Bureau in 1960.

FIGURE 30

MHT 322,752. Reproduction of the thermoscope traditionally ascribed to Galileo. A glass tube 80 cm long and 0.7 cm in diameter, with a pear-shaped bulb at the top, dips into a vessel of water 9 cm in diameter and 9 cm high. Changes of temperature—and also of pressure—alter the volume of air in the bulb and cause changes in the level of the water in the tube. Copy of instrument in the Museum of the History of Science, Florence, Italy, 1963. (Smithsonian photo 61900.)

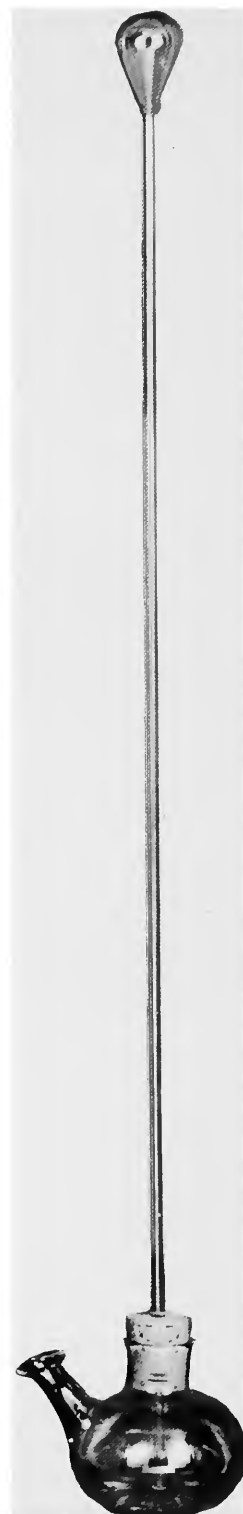

Chapter 3

Thermometers and Thermographs

Early History

A thermometer is an instrument for quantifying the sensations “hot” and “cold.” Temperature is a quantity of a very special sort, and if we look into the matter carefully we shall find that until recent times it has been necessary to specify it in terms of measurable changes in some chosen property of some chosen substance.⁶⁴ The property usually chosen is the volume, and the substance a liquid or a gas, though when a gas is used we may also measure the pressure needed to compress it to a constant volume. The earliest thermometers were air thermometers in which a change in the volume of an enclosed quantity of air was taken to measure the change in temperature.

Any “meter” must have a scale, and an instrument that shows merely that the temperature has changed should be called a thermoscope rather than a thermometer. The air thermoscope has its origin in a pneumatic experiment performed in antiquity by Hero of Alexandria and by Philo of Byzantium. A Latin translation of Hero’s

Pneumatics was printed in 1575,⁶⁵ and Italian translations in 1589 and 1592 caught the attention of a number of scholars, especially in Italy. The pertinent experiment is one in which water, partly filling a vessel that is closed except for an exit tube, is driven out through the tube by the expansion of the air in the vessel when it is heated. It was not a thermometer or even a thermoscope; it was “a fountain that drips in the sun.”

Several lines of evidence converge to persuade us that the great Italian philosopher Galileo Galilei made this experiment in a form that converted it into a thermoscope. This was most probably between 1592 and 1600. The traditional form of Galileo’s thermoscope is shown in figure 30, which is a photograph of a reproduction (MHT 322,752) of an instrument made many years after the event. A similar reproduction in the Museum collections is MHT 322,754. It should be noted that Galileo never published any account of his experiment, although in 1612 or 1613 he claimed in a letter that he had invented the thermometer. By this time Santorio Santorre,

⁶⁴ See Ernst Mach, *Die Prinzipien der Wärmelehre* (Leipzig, 1896); also W. E. K. Middleton, *A History of the Thermometer and its use in Meteorology* (Baltimore: The Johns Hopkins Press, 1966), pp. 48–50.

⁶⁵ *Hieronis Alexandrini spiritalium liber. A Federico Commandino Urbinatē, ex graeco nuper in latinum conversus . . .* (Urbino, 1575).

who is important in the history of medicine, had used the thermoscope as a thermometer in his medical practice by measuring the movement of the water with a pair of dividers;⁶⁶ and by 1611 someone had provided the air thermoscope with a scale, as is clear from a figure and a somewhat garbled text in a manuscript bearing that date.⁶⁷

The invention of the air thermometer has been claimed for several others;⁶⁸ however, the instrument is of limited utility at the best, because the changing pressure of the external air acts on the air contained in the instrument, so that it is impossible to separate the effects of pressure and temperature. In a room of constant temperature it would act as a baroscope, and this is the reason for the survival in the Low Countries of the peculiar and characteristic form of air thermoscope called by Henri Michel "le baromètre liégeois."⁶⁹ This can best be described by reference to figure 31, which shows a specimen in the Museum (MHT 322,299).

Liquid-in-glass Thermometers

The fact that the pressure of the atmosphere varies had become clear by 1650.⁷⁰ At some time in the succeeding decade the sealed spirit-in-glass thermometer was invented by Grand Duke Ferdinand II of Tuscany, but it should be mentioned that a bulb and tube, filled with water but not sealed, was used as a thermoscope at least as early as 1632 by a French country doctor named Jean Rey, who had never even heard of the air thermometer.⁷¹

The Grand Duke used spirit of wine as a thermometric liquid, and sealed the thermometer.



FIGURE 31

MHT 322,299. Weather glass or "baromètre liégeois" of clear glass shaped like a teapot with a very long, mainly vertical spout, flat on the side away from the spout for hanging against a wall. When this is partly filled with a liquid, the level in the spout will depend on both the atmospheric pressure and the temperature of the enclosed air. In the fairly uniform temperature of a room, the instrument will act as a rough baroscope. 12 cm diameter x 21 cm long. Spout 15 cm long. Mounted on a stand. Presented by Mr. Silvio A. Bedini, Washington, D.C. (Smithsonian photo 61907.)

⁶⁶ Santorio, *Commentaria in artem medicinalem Galeni* (Venice, 1612), part 3, chapter 85, item 10.

⁶⁷ Bartolomeo Telioux, *Mathematica maravigliosa* Paris, Bibliothèque de l'Arsenal, ms. 8525.

⁶⁸ See Middleton, op. cit. (footnote 64), chapter 1.

⁶⁹ Or "Liège barometer." See Michel, *Physis* (Florence), vol. 3 (1961), pp. 205-12.

⁷⁰ See p. 8.

⁷¹ See Middleton, op. cit. (footnote 64), p. 27.

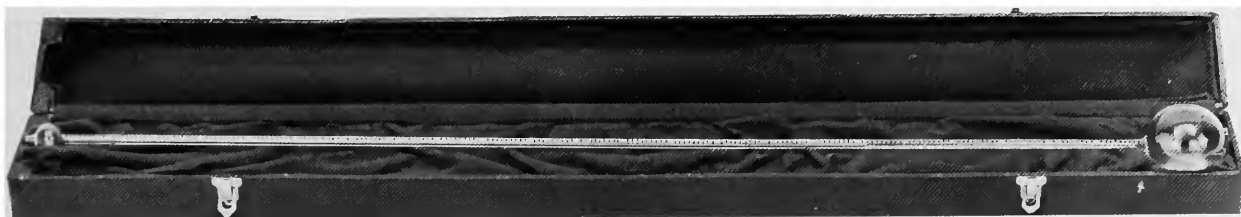

FIGURE 32

MHT 322,750. Reproduction of a Florentine spirit-in-glass thermometer. The spherical bulb is about 6.5 cm in diameter, and the tube is 94 cm long. There are 230 divisions with the hundreds marked with light blue dots of enamel, the tens with white, and the units with black dots. Copy of an instrument in the Museum of the History of Science, Florence, Italy. 1963. (Smithsonian photo 61911.)

He was fortunate in having a superb glassblower at his court, Mariani by name, who made these sealed thermometers in several sizes,⁷² all with the degrees marked with beads of glass of various colors, as in the replica in the Museum (MHT 322,750, figure 32). There were no fixed points, and the remarkable comparability of those that have been preserved must have been due to the skill of the glassblower, a situation that obviously left much to be desired. The subsequent history of the thermometer is very largely that of attempts to construct thermometers that could be made comparable from first principles. This led to more than a score of different scales of temperature, some, like those of Hooke⁷³ and Réaumur,⁷⁴ with one fixed point; others, like the scale of Fahrenheit⁷⁵ and the centigrade scales,⁷⁶ with two. Of all these scales, only three survived into the 19th

century—the centigrade scale and those of Fahrenheit and Réaumur—and now only the first two are in general use anywhere. It was common in the 18th century to put a number of scales beside a thermometer tube, and at least two exist with 18 each. By the end of the 18th century, we find many with multiple scales, as in the thermometer reportedly carried by Dr. John Jeffries of Boston on his balloon ascensions in 1784 and 1785.

NASM 1963-28. Mercury thermometer with scales of Réaumur and Fahrenheit, marked "T. F. Poole [or T. & F. Pool?] Boston." Mounted in a glass-covered case 73 cm x 6 cm.

There are also multiple scales in the specimen, MHT 316,451, which was used in the early 19th century in the teaching laboratories of the U.S. Military Academy.

MHT 316,451. Early-19th-century mercury thermometer with scales marked Réaumur, Fahrenheit, and Celsius, mounted on a board 5.3 x 34 cm. The scale and other markings are almost obliterated. Transferred from the U.S. Military Academy in 1959.

⁷² The making of them is described in the first chapter of the *Saggi di naturali esperienze fatte nell'Accademia del Cimento* (Florence, 1667), published by the short-lived Academy of Experiments as an account of their work.

⁷³ Robert Hooke, *Micrographia* . . . (London, 1665), pp. 38-39.

⁷⁴ René-Antoine Ferchault de Réaumur, *Mem. Acad. r. des Sci. Paris* (1730), pp. 452-507; *ibid.* (1731), pp. 250-96.

⁷⁵ Daniel Gabriel Fahrenheit, *Phil Trans*, vol. 33 (1724), pp. 78-79.

⁷⁶ Such as that of Anders Celsius, *Kongl. Svensk. Vet. Akad. Handlingar*, vol. 3 (1742), pp. 171-80. The history of these scales is complicated; see Middleton, *op. cit.* (footnote 64), pp. 89-105.

While the Réaumur scale was originally intended to have only one fixed point, the freezing point of water, each degree being defined by an expansion of 1/1000 of the original volume of the spirit of wine that he used, it was soon modified by other people and referred to a mercury thermometer with the melting point of ice at 0° R. and the boiling point of water at 80° R. The Fahrenheit scale, originally referred to the ice point and "blood heat," soon came to have the boiling point at 212° F. Towards the end of the 18th century, the upper point was obtained by hanging the thermometer with the bulb above boiling water, and became the steam point. Thus, we now have:

<i>Ice point</i>	<i>Steam point⁷⁷</i>
----------------------	-------------------------------------

The centigrade (or Celsius) scale, used for scientific purposes in English-speaking countries and for all purposes elsewhere.

0°	100°
----	------

The Fahrenheit scale, in general use in English-speaking countries.

32°	212°
-----	------

The Réaumur scale, now obsolete.

0°	80°
----	-----

For certain purposes in meteorology and engineering, the Kelvin or absolute scale is convenient. In this, the ice point is 273° K⁷⁸ and the steam point 373° K. The Museum has an English thermometer graduated on the absolute scale (MHT 314,556, figure 33).

The technical improvement of the thermometer as a piece of apparatus is partially represented in the collections. In France during the 18th century the thermometer tube was generally mounted on a wooden board, sometimes covered with paper on which the scale was drawn; sometimes not, as in specimen MHT 316,451 previously mentioned. Bulbs were usually spherical. Fahrenheit and his successors in Holland

⁷⁷ At a standard atmospheric pressure, defined by international agreements.

⁷⁸ More precisely 273.15°.



FIGURE 33

MHT 314,556. Thermometer on porcelain base, 24 x 3.6 x 0.6 cm. The spherical bulb, 0.9 cm in diameter, projects 4 cm below the base. This thermometer is graduated on the white-backed tube, and numbered on the base. The scale runs from 243 to 325 degrees absolute (Kelvin). The tube is marked with the monograms of Kew Observatory, N. & Z., and the Meteorological Office, the last with the number "29." Calibration marks at 273° and 320° K. The base is marked "Absolute" and "Negretti & Zambra, Scientific Instrument Makers, London" and has their monogram. Transferred from the Weather Bureau in 1954. (Smithsonian photo 61901-C.)

used cylindrical bulbs for the most part, and mounted their thermometers on neat strips of sheet brass on which the scales were engraved. Ivory was often used for the scales of small thermometers, as in MHT 327,557.

MHT 327,557. Very small pocket mercury-in-glass thermometer, the glass part only 6.5 cm long, mounted on a thin ivory panel 7.2 x 1.8 cm, carrying the scale, -20 to +50 [°C?]. Spherical bulb. The ivory panel slides into a sheath of dark wood with neat ivory stringing. Received in 1965.

A way of protecting the scale from the weather, devised about 1810, was to draw it on paper, roll this into a cylinder, and enclose it and the thermometer tube in an outer sheath of glass. The Museum has an early example, designed as a bath thermometer (MHT 316,458).

MHT 316,458. Bath thermometer, probably dating from about 1810 or thereabouts. An outer protective tube 24 cm long and 1.4 cm in diameter has a spherical bulb, now broken,



FIGURE 34

MHT 316,459. Thermometer, 23 cm long with enclosed rolled-paper scale graduated -32° to $+55^{\circ}$ R and -40° to $+150^{\circ}$ F and marked "Thermometer nach Réaumur & Fahrenheit." Transferred from the U.S. Military Academy in 1959. (Smithsonian photo 61833-B.)



FIGURE 35

MHT 316,446. Handsome enclosed-scale mercury-in-glass thermometer 48 cm x 1.6 cm, with ellipsoidal bulb. Milk-glass scale in fifths of a degree, -23° to $+50^{\circ}$, and marked "Celsius." No maker's name. Brass cap. Transferred from the U.S. Military Academy in 1959. (Smithsonian photo 61899-A.)

at the bottom, which must have been filled with mercury in order to make the thermometer float upright. This outer tube encloses a thermometer with red spirit and a rolled-paper scale, graduated from -35 to $+80^{\circ}$ R. The scale carries the legend "Thermometre de bain" and a number of indications, such as "Eau bouillante" at $+80$ to "Paris 1740" at -11 , "1777" at -16 , and "1788" at -17.5 . "Syrie" is at $+50$; "Chaleur humaine" at $+32.5$; "Bain" at $+26$; "Ver à Soie" at $+19$, and so on. Transferred from the U.S. Military Academy in 1959.

The Museum also has a later, more meteorological instrument (MHT 316,459), which is shown in figure 34.

A better way is the enclosed-scale thermometer almost universally used in central and eastern Europe for both meteorological and chemical purposes under the name *Einschlussthermometer*. We shall call it the "enclosed-scale thermometer," noting by reference to figure 35 the milk-glass

scale fastened to the thin thermometer tube and enclosed in an outer tube which is hermetically sealed, the bulb being left free. The Museum has many such thermometers, some of which will be more particularly referred to below.

Chemical thermometers in most other countries usually have the scale etched on the tube itself, a construction probably invented shortly before 1800, and greatly improved in 1844 by Bodeur, who provided the tube with a ribbon of white glass to act as a background for the mercury (or spirit) and the scale.⁷⁹ Except for the circumstance that they may have been used as standard thermometers for calibration in meteorological observatories,⁸⁰ such instruments scarcely have a

⁷⁹ Bodeur, *Comp. Rend. Acad. Sci.*, vol. 18 (1844), p. 1132.

⁸⁰ See Leonard Waldo, "Examination of Thermometers at Yale Observatory," *Popular Science Monthly*, vol. 18 (1880-81), pp. 367-74.



FIGURE 36



FIGURE 37

place in this catalog, but we shall mention one that qualifies on the basis of the above rule (MHT 317,451).

MHT 317,451. Nicked brass tube, 55 x 1.4 cm, with screwed caps, containing a mercury thermometer 51 cm long, with a cylindrical bulb blown directly from the tube with its white-glass strip. Scale -4.8 to 104.6° C in fifths on the tube. Marked "Yale Observatory Standard N° 51. Made by Tonnelot à Paris. Equal graduations. Crystal-glass tube made April 1879." Transferred from the Weather Bureau in 1960.

The point of noting the kind of glass and the date of manufacture is that a slow secular change in the readings was normal in thermometers made at that time, though this has since been greatly reduced by better glasses and improved manufacturing techniques.

Coming back to meteorological thermometers, we find that the brass mount favored by Fahrenheit was preferred by the British Navy, and a

FIGURE 36

MHT 317,456. Mercury-in-glass thermometer on a flat brass mount 25 x 2.2 x 0.2 cm. Total length 30 cm. Cylindrical bulb. Scale, -10 to 125 [$^{\circ}$ F] on the mount only; the tube is located by a nib in a hole near one end of the mount. The tube has a white-glass strip; the bulb is not blown integral. Mount engraved "J. Green N. Y. Sig. Ser. U.S.A. S 184." Transferred from the Weather Bureau in 1960. (Smithsonian photo 61830-D.)

FIGURE 37

MHT 317,455. Mercury-in-glass thermometer in a brass mount 24 x 2.4 x 0.15 cm with a formed groove. Total length 28 cm; cylindrical bulb. Scale, -40 to 120 [$^{\circ}$ F] on tube, numbers and major divisions repeated on mount. Tube marked "U.S. 11065." Mount marked "H.J. Green B'klyn. N. Y. N° 11065 U.S. Weather Bureau." Transferred from the Weather Bureau in 1960. (Smithsonian photo 61832-C.)

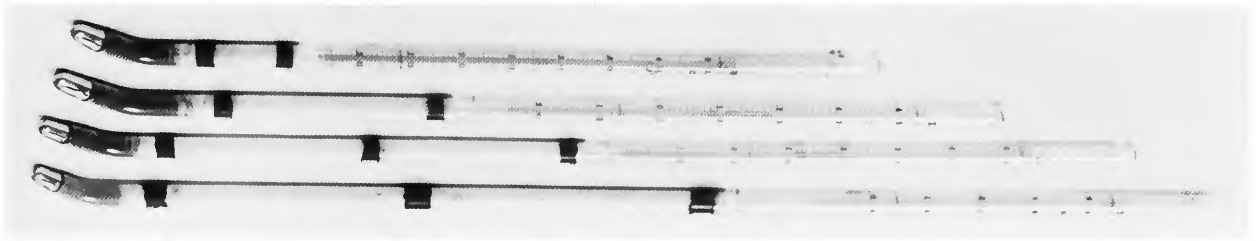

FIGURE 38

MHT 316,263. Four Russian earth thermometers designed for depths of 5, 10, 15, and 20 cm respectively. They are mercury enclosed-scale thermometers graduated in half-degrees C, with short cylindrical bulbs about 0.8 cm in diameter x 1.2 cm long, the last 2 cm above the bulb being bent up at 45°. They all bear

a trademark or monogram and three of them the legend "ГосТ 112-41." The parts of the protecting tubes that are to be buried are packed, apparently with glass wool or cotton. The whole is in a wooden box 58 x 12 x 3.7 cm. Transferred from the Weather Bureau in 1959. (Smithsonian photo 61899-D.)

standard model was designed at Kew Observatory in 1854, whereupon a thousand such thermometers were immediately ordered by the Smithsonian Institution, half from Casella & Co. and half from Negretti & Zambra.⁸¹ Thermometers of this kind were soon made in the United States by James Green, one of whose thermometers, supplied to the Signal Service of the U.S. Army about 1880, is in the Museum (MHT 317,456, figure 36). It will be noted that the scale is on the mount only, so that its accuracy depends on the tube maintaining its position. Two decades later, James Green's nephew and successor had improved the design by etching the scale on the tube itself, and by forming a groove in the brass strip, which not only gives the thermometer better support, but stiffens the mounting. This design is illustrated by MHT 317,455, figure 37. Eventually, stainless steel was substituted for brass, with a further increase in durability.

Meanwhile for fixed stations the British were using thermometers mounted on porcelain backs, as in the one previously discussed (MHT 314,556, figure 33). To render the scales impervious to the weather, they later combined the chemical

thermometer and the *Einschluss thermometer* into an instrument having the scale, with its numbers, engraved on the tube, a construction introduced in 1931 and still in vogue.

Rather special thermometers are used for measuring the temperature of the soil at various depths. For small depths, thermometers can be encased in wooden rods shod with metal, as in two specimens in the Museum (MHT 316,008)⁸² intended for the use of gardeners, for instance in cold frames.

MHT 316,008. Two mercury thermometers, each in a wooden mount with a bluntly pointed brass end, total length 30 cm, diameter 2.2 cm. The scale, on wood, appears in a cutaway portion near the top. Intended for gardeners. Marked "L. Casella London." One thermometer has the scale graduated from 20 to 130° F, the other from 30° to 120° F. Deposited by the Smithsonian Astrophysical Observatory in 1958.

In Europe, more systematic observations of this kind are often taken with enclosed thermometers having the last part of the tube before the bulb bent up, as in a set of Russian thermometers shown in figure 38 (MHT 316,263). They are installed in the soil with the bulb horizontal at

⁸¹ Kew Committee (J. P. Gassiot, chairman), *B.A.A.S., Liverpool, 1854, Report of Council*, p. xxvii.

⁸² See L. Casella & Co., *Catalogue* of 1871, p. 46.

FIGURE 39

FIGURE 39

MHT 314,558. Thermometer with a bulb in the form of a narrow tube about 2 mm in outside diameter, bent 16 times to form a rectangular grid 6 x 3 cm, with 14 bars. The scale tube is 51 cm long, marked in half degrees from -18 to $+120$. The whole is mounted on a hardwood board $64 \times 5.8 \times 1.5$ cm, with brass mounts and a hanging ring. The board carries an engraved "A" near the top, but no indication of origin. Transferred from the Weather Bureau in 1954. (Smithsonian photo 61899-C.)

FIGURE 40

MHT 317,459. Minimum thermometer of Rutherford type, length 36 cm. Mounted on a metal plate $30 \times 2.3 \times 0.1$ cm, with formed groove to stiffen it. Cylindrical bulb. Scale, -90 to $+110^\circ$ F, on tube, also numbered on the mounting, which is marked "H. J. Green B'klyn. N. Y. U.S. Weather Bureau. Minimum." Transferred from the Weather Bureau in 1960. (Smithsonian photo 61909-D.)

the appropriate depth and the stem sloping backwards at an angle of about 45 degrees. Plainly such an installation involves disturbing the soil a good deal. For greater depths a strong tube with a point at the end is forced into the soil or thrust down a borehole, and a thermometer having its bulb surrounded by a mass of something with a large capacity for heat, commonly paraffin wax, is lowered into the tube.

The idea of the paraffin wax is to prevent the indications of the thermometer changing appreciably while it is being read. With the opposite goal of making a thermometer respond as quickly as possible, very elaborately shaped bulbs have sometimes been constructed, of which our specimen MHT 314,558 (figure 39) is an extreme example. Such thermometers are likely to be more greatly affected by the secular changes previously mentioned on page 42.

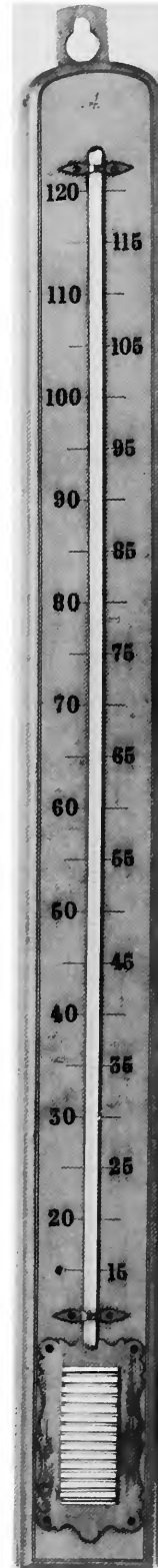

FIGURE 40



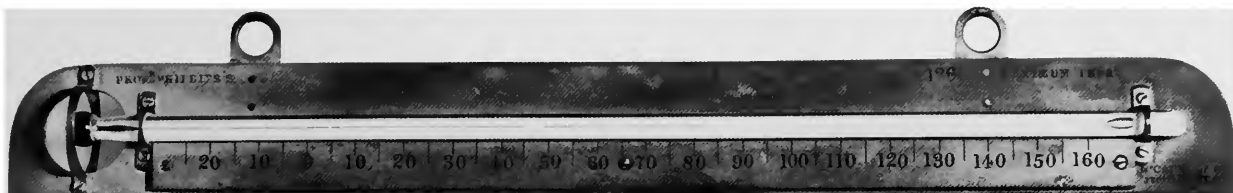

FIGURE 41

MHT 315,998. Maximum thermometer invented by John Phillips in 1832. Its metal back is marked "Prof: Phillips's Maximum Ther: L. Casella & C^o fecit London 1836." The scale, marked on the tube and numbered on the metal back, runs from -30° to $+160^{\circ}$ [F]. The tube has a white-glass strip behind the bore. Overall length, 35 cm. Deposited by the Smithsonian Astrophysical Observatory in 1958. (Smithsonian photo 61900-D.)

Maximum and Minimum Thermometers

The highest and the lowest temperature during the day have long been of interest. The first practical construction of thermometers to register these quantities was due to Lord Charles Cavendish and dates from 1757,⁸³ but these instruments, while ingenious, were elaborate and hard to transport. But in 1790 a pair of thermometers were devised by John Rutherford, a Scottish country doctor, of which his minimum thermometer is in essentials the one used almost universally by meteorological services today. The maximum, which was simply a mercury thermometer with a conical index of ivory, has long been superseded. The Rutherford minimum thermometer was a spirit thermometer containing a conical glass index with its point towards the bulb and immersed in the spirit. By 1826 at the latest the little cone had evolved into a dumbbell of dark glass,⁸⁴ and so it remains.

The Museum has about a score of these Rutherford-type minimum thermometers, of which MHT 317,459, figure 40, is a fairly recent example.

The first reasonably successful maximum thermometer was invented in 1832 by John

Phillips, a geologist.⁸⁵ It was just a mercury thermometer in which about a centimeter of the column is separated from the remainder by a tiny speck of air. The instrument is installed in a horizontal position, and the short detached part of the column remains stationary when the mercury falls, and acts as an index. The Museum possesses two of these thermometers, one of which (MHT 315,998), is shown in figure 41. Such instruments continued to be made until at least 1875, but were eventually superseded by the well-known maximum thermometer with a constriction in the tube, now also used universally as a clinical thermometer. It was patented by Negretti & Zambra on 8 March 1852.⁸⁶ Mercury is forced past the constriction when the temperature is rising, but as soon as it begins to cool the column breaks off at the constriction, leaving the outer end of the mercury thread to indicate the maximum temperature. The column is reunited by centrifugal force, usually by swinging it, a process which is occasionally disastrous to the thermometer. About 1905, in an attempt to improve this process, the U.S. Weather Bureau introduced a special holder for the maximum and minimum thermometers known as the Townsend support,⁸⁷ which enables

⁸³ *Phil. Trans.*, vol. 50 (1757), pp. 300-10; Middleton, *op. cit.* (footnote 64) pp. 150-52.

⁸⁴ K. L. G. Winckler, *Annalen der Physik*, vol. 6 (1826), pp. 127-32.

⁸⁵ *B.A.A.S. Report, Oxford, 1832*, Sections, pp. 580-81.

⁸⁶ British Patent 14,002 of 1852.

⁸⁷ U.S. Weather Bureau, *Instructions for Cooperative Observers*, 3rd ed. (Washington, 1906), pp. 17-18.

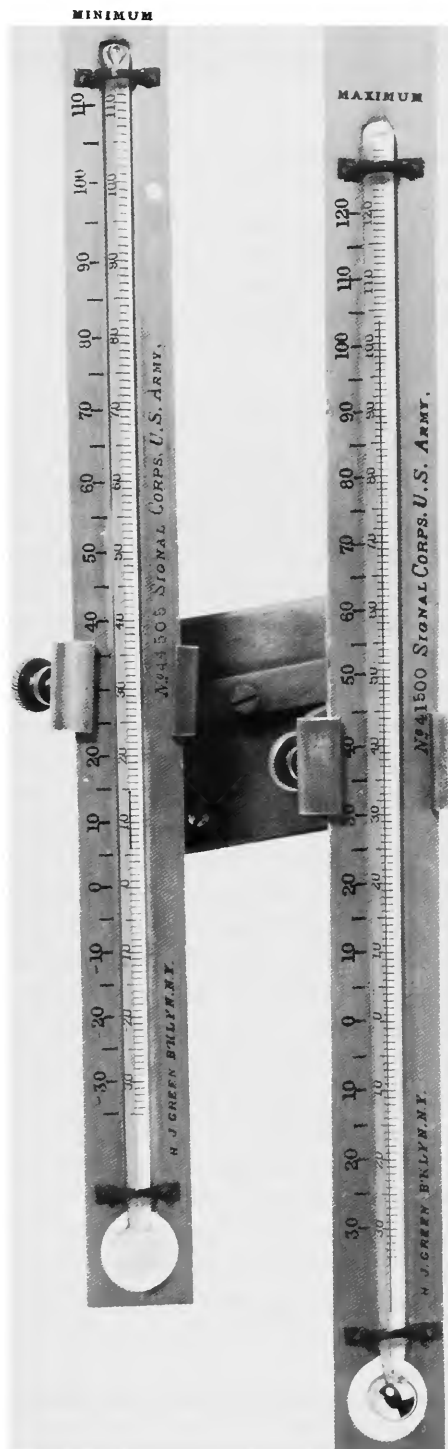

FIGURE 42

MHT 308,198. Townsend support, with standard maximum and minimum thermometers. The base, 7.9 x 5.2 cm, is to be screwed to a vertical surface, and is arranged with two posts so that the minimum thermometer is held 2.5 cm, and the maximum 6 cm, in front of the base. The thermometers are marked "H. J. Green B'klyn. N.Y. No. 41500 Signal Corps U.S. Army Maximum" and "H. J. Green, B'klyn. N. Y. No. 44505 Signal Corps U.S. Army Minimum" respectively. The base is marked "Julien P. Friez & Sons." Transferred from the Signal Corps in 1923. (Smithsonian photo 61904-A.)

the maximum thermometer to be released from its normal horizontal position and whirled rapidly round, and also permits the minimum thermometer to be tilted to let the index slide down to the end of the spirit column. The Museum has two of these assemblies, of which MHT 308,198 is illustrated in figure 42.

As long ago as 1782, James Six of Canterbury invented the combined maximum and minimum thermometer that bears his name.⁸⁸ In its household form this is probably the most familiar of all meteorological instruments except the wind vane. It needs little description other than to emphasize that the thermometric fluid is alcohol contained in a relatively large bulb, the mercury being only a means of indication, confined between two volumes of alcohol, of which the smaller is given a little room to move. About 1790 Joseph Gatty, an Italian who had settled in Philadelphia, made one of these thermometers for George Washington's house at Mount Vernon. The Museum has a modern (1960) replica of this (MHT 317,699, figure 43), the

⁸⁸ Six, *Phil. Trans.*, vol. 72 (1782), pp. 72-81.

FIGURE 43

MHT 317,699. Reproduction of a maximum-and-minimum thermometer of Six's type. The original was constructed about 1790 by Joseph Gatty. The glass parts are mounted on a mahogany board 40 cm x 8 cm x 1 cm thick. The scales, -30 to $+150$ [$^{\circ}\text{F}$] for the maximum, -50 to $+125$ for the minimum, are engraved directly on the wood, the numbers being stamped. The indexes are small pins sheathed in glass dumbbells. Copy of an instrument preserved at Washington's home, Mt. Vernon, made by Val Hergesell and William Bridges in 1960. (Smithsonian photo 61899.)

FIGURE 44

MHT 314,533. "Kiosk" thermometer intended for public display. A modified Six's maximum and minimum thermometer with the ends of the tube bent at right angles for 10 cm behind the flat metal base, 40 x 5 x 0.1 cm, on which the tube is mounted. Graduations on the tube, repeated, with figures, in white on the blackened base, -40 to $+110$ [$^{\circ}\text{F}$]. The tube is marked "U-S N^o 32;" the base "U.S. Weather Bureau No 32 Taylor Instrument Companies Rochester, N.Y. Tycos" and a trademark. The liquid is "composed of alcohol and creosote." Transferred from the Weather Bureau in 1954. (Smithsonian photo 61900-A.)

glass parts of which are very like those in Six's instrument.

The trouble with thermometers containing both mercury and alcohol is that the latter wets the glass, and can be gradually transferred past the mercury, changing the zero of the instrument. For this and other reasons, this type of thermometer is not used for serious meteorological observations; but the Museum has a special form (MHT 314,533) that was part of the instrumentation of a "kiosk" devised by the Weather Bureau for displaying meteorological information to the

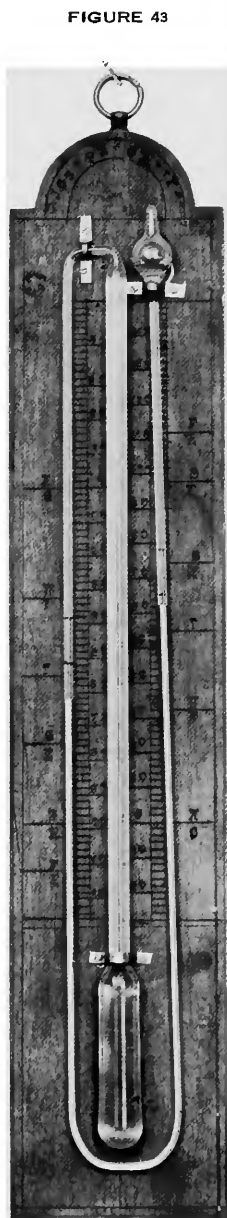

FIGURE 43



FIGURE 44

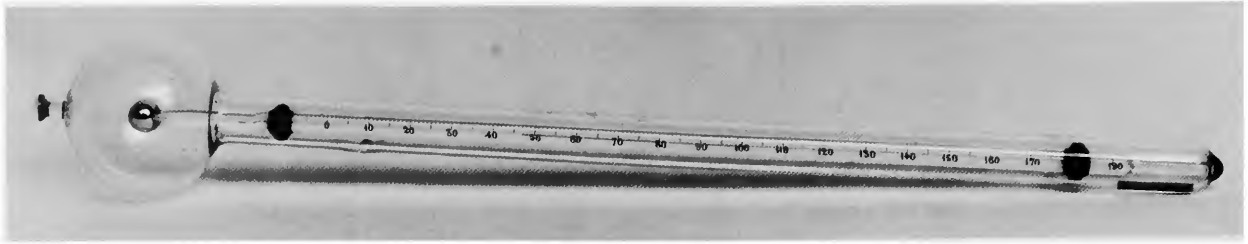

FIGURE 45

MHT 314,560. Hicks' vacuum thermometer with electrodes. A mercury maximum thermometer, 38 cm long, enclosed in an evacuated jacket which has a spherical bulb, about 5.6 cm in diameter, concentric with the thermometer bulb. The tube has a white-glass back strip. The scale, -5 to $+192$ [$^{\circ}\text{F}$] is marked on the thermometer tube, and also "202 J. Hicks. 8 Hatton Garⁿ London Hicks's Patent N^o 3647 [Kew Observatory monogram] 14951." Near the ends of the jacket are two platinum electrodes for connecting to a spark coil so that the vacuum could be checked. Transferred from the Weather Bureau in 1954. (Smithsonian photo 61832-A.)

public.⁸⁹ The thermometer itself is shown in figure 44.

There were various modifications of Six's thermometer, one of which was straight and had mercury for a thermometric fluid, with naphtha above it, with two indices, one pushed up by the mercury and the other drawn back by the naphtha.⁹⁰ This may have inspired H. J. Green to design two soil thermometers that are in the Museum (MHT 314,540 and 314,541).

MHT 314,540. Soil thermometer in a wood and brass frame, 59 cm overall. The construction of this is not clear. It contains mercury and a transparent liquid, and there are two dumbbell-shaped indices in the tube. The column is now broken up. A nicked scale is adjacent to the upper part of the tube, which is exposed by cutting away the wood. The tube is graduated from -20 to $+177$ [$^{\circ}\text{F}$], and also numbered on the metal. The scale is marked "H. J. Green B'klyn. N.Y. N^o 8 U.S. Weather

Bureau." Transferred from the Weather Bureau in 1954.

MHT 314,541. Soil thermometer, similar to MHT 314,540, but 66 cm overall. The scale, from $+5$ to $+152$ [$^{\circ}\text{F}$] is marked "N^o 11 U.S. Weather Bureau." On a brass band 35 cm from the lower end is engraved "Henry J. Green B'klyn. N.Y. \odot 12 in." The column is now broken up. Transferred from the Weather Bureau in 1954.

One use for a minimum thermometer is to study the incidence of ground frost by putting it just above short grass. For this use, thermometers frequently have their scales protected by a glass tube, either hermetically sealed or, as in MHT 314,553, attached with cement. Similarly a maximum thermometer, usually with the bulb blacked and the whole thermometer enclosed in a vacuum jacket, used to be employed to estimate the radiation from the sun.⁹¹ A refinement of this was to have two similar thermometers, one with the

⁸⁹ C. F. Marvin, *The Weather Bureau Kiosk* (Weather Bureau no. 522) (Washington, 1914), pamphlet, 6 pp.

⁹⁰ John G. Macvicar, *Chemical Society Journal*, vol. 11 (1859), pp. 106-7.

⁹¹ Negretti & Zambra, *A Treatise on Meteorological Instruments . . .* (London, 1864), pp. 86-87, claimed to have invented the vacuum black-bulb thermometer.

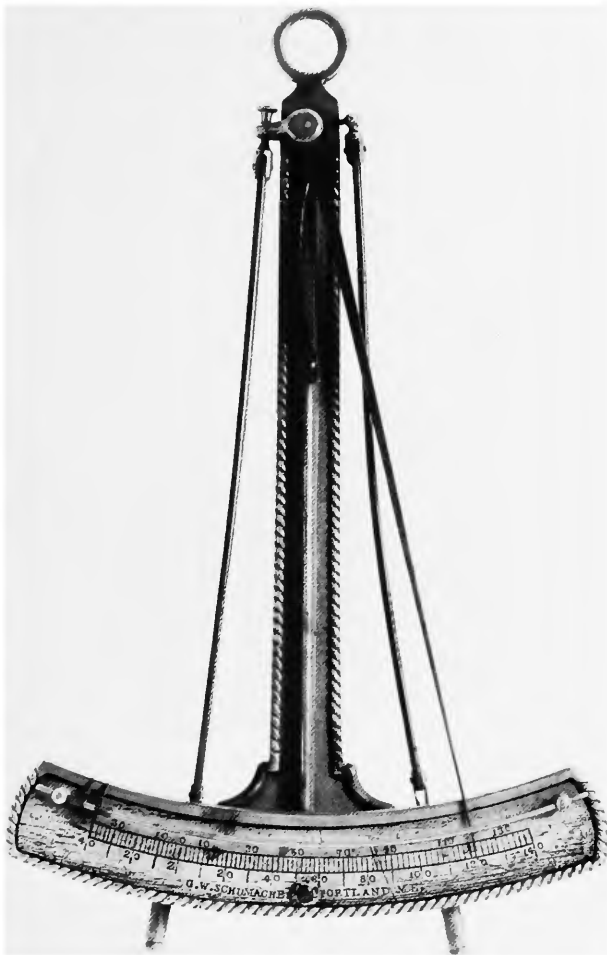

FIGURE 46

MHT 308,948. Thermometer of G.W. Schumacher. A thermometer operating on the differential expansion of ebonite and brass, the expansions of two hard-rubber strips each 19 cm long being added by a lever system and communicated to a spring-loaded pointer. The pointer can move two light indexes on a curved rod, to indicate the maximum and minimum. The scale, from -40 to $+140$ [$^{\circ}\text{F}$] is marked "G.W. Schumacher Portland, Me." Schumacher was awarded U.S. Patent 172,181 on 11 January 1876. Overall length 29 cm, width 11 cm. This was a Patent Office model, and was transferred from the Patent Office in 1926. (Smithsonian photo 61833-D.)

bulb blacked, the other with it bright.⁹² The Museum has a French thermometer of this sort with a bright bulb (MHT 314,559). One of the difficulties of this technique is that the vacuum has to be very good, a serious problem in the 19th century, and in 1874 J. Hicks of London had the ingenious idea that the electrical discharge might be used to check the vacuum,⁹³ and provided his thermometers with electrodes for the purpose, as in MHT 314,560, figure 45. Now, these techniques are only of historical interest.

MHT 314,553. A grass-minimum thermometer of the Rutherford type, 30 cm long. All but the spherical bulb and the last 1.5 cm of the tube is sealed with black cement into a heavy outer glass tube 1.2 cm in diameter. Scale -77 to $+135$ [$^{\circ}\text{F}$]. Marked on the thermometer tube: "J. & H.J. Green. N.Y. Signal Service U.S. Army No 11." Transferred from the Weather Bureau in 1954.

MHT 314,559. Mercury thermometer 40 cm long, enclosed in a 15 mm diameter jacket with a spherical bulb 5 cm in diameter. The jacket, presumably evacuated, has "N^o 1" marked on it. On the tube of the thermometer, graduated in fifths from -20° to $+82.2^{\circ}$ C, is marked "(Centigrade) J. Salleron 24 rue Pavée (au Marais) Paris." Transferred from the Weather Bureau in 1954.

Bimetallic Thermometers

Solid substances change their dimensions to varying degrees as their temperature changes, but to an extent much less noticeable than liquids, indeed so little that special techniques had to be developed before the expansion of solids could be useful for the construction of thermometers.

The answer was the bimetallic strip or bimetal, a compound strip made by riveting, soldering,

⁹² The idea originated with Sir John Leslie, who applied it to his differential thermometer, and called the result a pyroscope. See Leslie, *On the relations of air to heat and moisture* (Edinburgh, 1813), p. 50.

⁹³ Hicks, *Quarterly Journal Meteorological Society*, vol. 2 (1874), pp. 99–102.

or preferably welding together two strips of different metals, appropriately chosen so as to have widely different coefficients of expansion. The curvature of such a compound strip changes with change of temperature. Today, one of the metals is usually a special nickel steel that combines resistance to corrosion with an expansion that is very nearly zero.

It is almost certain that a pocket metallic thermometer made in 1767 at Norriton (now Norristown) in Pennsylvania by the celebrated American instrument maker David Rittenhouse used a bimetallic strip.⁹⁴ If so, this is the earliest one that we know about. Ten years later J. H. Lambert wrote that someone in England had thought of the idea.⁹⁵

Bimetallic thermometers are used less frequently as indicating instruments than in thermographs or in thermostats. During the 19th century, however, there was a vogue for pocket thermometers of this sort. There is one in the Museum (MHT 325,408), which is referred to here even though it qualifies as a meteorological instrument only because it is supposed to measure the temperature of the air.

MHT 325,408. Metallic thermometer in the shape of a watch 5.0 cm in diameter and 1.2 cm thick, with glass front and back. There is a white dial with concentric scales from -41 to $+51$ [$^{\circ}\text{C}$], -30 to $+40$ [$^{\circ}\text{R}$], and -38 to $+122$ [$^{\circ}\text{F}$], over which a thin blue pointer moves. There are two brass setting hands. The instrument, unsigned, is in a brown leather case 6 cm in diameter x 1.5 cm thick. Received in 1964.

An instrument that is not strictly a bimetallic thermometer, but does operate with the differential expansion of solids is MHT 308,948 (figure 46). The solids are brass and ebonite (hard rubber), but the latter though having a relatively great expansion is not a very stable substance, and the instrument has little scientific importance.

⁹⁴ Its external appearance is described by William Barton, *Memoirs of the Life of David Rittenhouse* (Philadelphia, 1813), p. 155, note.

⁹⁵ Lambert, *Pyrometrie oder vom Maase des Feuers und der Wärme* (Berlin, 1779), p. 124. Lambert had died in 1777.

Recording Thermometers

Recording thermometers, often called thermographs, have been made on the principles of the air thermometer, the liquid-in-glass thermometer, and the metallic thermometer.⁹⁶ A special kind of metallic thermometer, the Bourdon tube, has also been used for this purpose. It is really a liquid-in-metal thermometer—a curved tube of elliptical cross section, entirely filled with a liquid such as alcohol, and changing its curvature as the liquid expands or contracts.

The oldest thermograph in the collection is a rather extraordinary instrument (MHT 317,416) devised by G. W. Hough of the Dudley Observatory, Albany, New York, about 1860. Instead of using a bimetal, Hough used the difference in expansion of straight rods of iron and brass, and, while it is extremely ingenious, it could not possibly have worked for long outdoors.

MHT 317,416. Mahogany box 49 x 17 x 14 cm, with a group of rods 39 cm long mounted along one side. There are six iron rods and five brass ones, each 0.23 cm in diameter. Their differential expansion is transmitted to an elaborate system of levers, chains, and a pulley, and there is also a complicated mechanism for moving a band of paper and making intermittent records, now far from complete. An experimental roll of paper was made up by pasting together strips, 13.5 cm wide, cut from the New York Times of Monday, 12 March 1860. Presented by the Dudley Observatory in 1960.

Next in date, and much more practical, is the bimetallic recording thermometer invented in 1887 by Daniel Draper of Central Park Observatory, New York City (MHT 316,942, figure 47).⁹⁷ This was the ancestor of millions of industrial instruments of all sorts, the flat circular chart having won the approbation of engineers, though not of meteorologists. This may in part be due to the great success of the recording

⁹⁶ Middleton, op. cit. (footnote 64), chapter 9.

⁹⁷ *Scientific Instruments by Henry J. Green, Successor to J. & H. J. Green, Manufacturer of Meteorological and Scientific Instruments . . . 771 Broadway, Cor. Ninth St., New York, 1887*, p. 39.



FIGURE 47

MHT 316,942. Daniel Draper's bimetallic thermograph. Height 35 cm. The cast frame is marked "Draper Self Recording Thermometer Patented 1887 Made for Henry J. Green 771 Broadway, N.Y." Draper received U.S. Patent 369,170, issued 30 August 1887. It can best be described in the words of Green's catalog: "Consists of a bimetallic thermometer in a case, together with a clock, which carries a disc, with a chart upon its axle, instead of hands like the ordinary clock. The very slightest variation or fluctuation in temperature causes motion in the thermometer, which is most completely and effectively communicated to a lever, the long arm of which carries a pen, with the point resting upon the chart on the face of the disk. The clock needs to be wound, the chart changed and the pen supplied with ink prepared for the purpose, once each week." The bimetal is missing. The dial is 23 cm in diameter. Presented by the Lick Observatory in 1960. (Smithsonian photo 61830.)

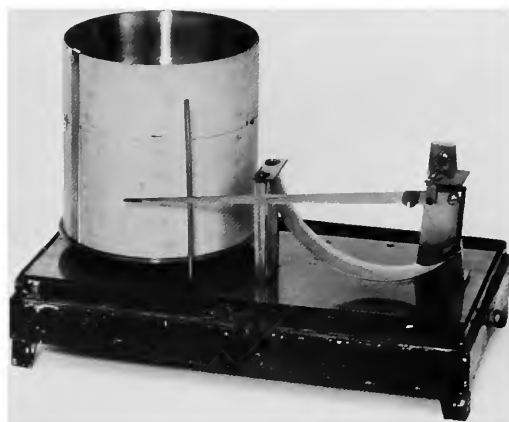

FIGURE 48

MHT 252,980. Early Richard thermograph. The weekly drum 9.3 cm diameter and 9 cm long carries a chart graduated from -30 to $+110$ [$^{\circ}\text{F}$], with the days of the week in English. The brass baseplate, 21 x 8.6 cm, carries the Richard Frères trademark (an early version) and the number "143." A curved Bourdon tube 10 x 2 cm operates the pen, now missing, through a link and lever. The outer case, 22 x 12 cm x 16 cm high, is of japanned iron, with one glass window and two circular apertures covered with netting. The Bourdon tube is inside the case. Transferred from the U.S. Geological Survey in 1909. (Smithsonian photo 61829-D.)

instruments of Richard Frères, in which the record is made on a drum turned by a clock inside it.⁹⁸ The Museum has several of their thermographs.

The earlier type,⁹⁹ of which MHT 252,980 is an example, is shown in figure 48. Later, recognizing that the case would protect the Bourdon tube from rapid changes of temperature, Richard Frères put the tube outside,¹⁰⁰ with the result shown in figure 49, which is a photograph of MHT 327,713. This construction was later copied by the Friez firm, with certain additions. The

⁹⁸ See also p. 29.

⁹⁹ Richard Frères, *Notice sur les instruments enregistreurs . . .* (Paris, 1886), pp. 8–9.

¹⁰⁰ *Ibid.*, pp. 18–19.

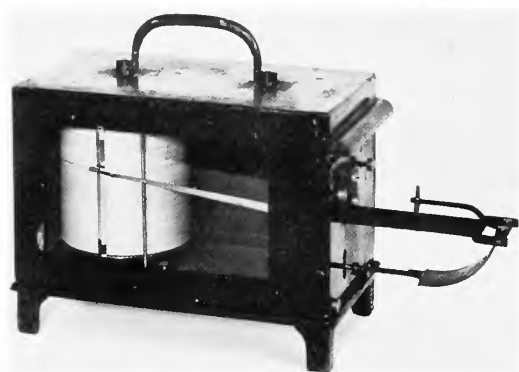

FIGURE 49

MHT 327,713. Richard Frères Bourdon-tube thermograph. It differs from MHT 252,980 in that the Bourdon tube is now outside the case, the base and one end of which are of cast iron, the top of japanned metal. The case is 23 x 12.5 cm x 17 cm high, and has a large glazed window. The instrument is 34 cm long overall; the curved Bourdon tube, entirely unprotected, is 7 cm long and 3.3 cm wide. The base is marked with the Richard Frères' later trademark and the number "39990," also "Made in France." Transferred from the U.S. Naval Observatory in 1966. (Smithsonian photo 61832-D.)

Museum has two of these under the number MHT 308,177, one of which is shown in figure 50.

Instead of making the Bourdon tube record directly on a drum, the Richard firm saw that it could be used with an electromechanical servo mechanism to indicate or record, or both, at any reasonable distance.¹⁰¹ The general principle of this is to have two insulated contacts, one on each side of the pointer of the thermometer—or indeed of any other instrument—not quite touching it, with two electromagnets arranged to move the pair of contacts in an appropriate direction to break whichever circuit is made by any movement of the pointer. At the same time, an indicating or recording

¹⁰¹ *Ibid.*, pp. 71–73.



FIGURE 50

MHT 308,177. Bourdon-tube thermograph. Of the two in the Museum, one is lacking its cover. Very similar to MHT 327,713, but with the base extended below the tube to give it some protection, and with a scale graduated from 5 to 100° F, the pointed end of the pen arm acting as an index. Each is marked on the base "Thermograph, Type ML18, Serial 114 [and 129 respectively] Signal Corps U.S. Army, Order 110,445 Date 6-26-23." The cover of one specimen is marked "Julien P. Friez & Sons Belfort Meteorological Observatory 1230 E. Baltimore Street Baltimore, Md. U.S.A." Transferred from the Signal Corps in 1923. (Smithsonian photo 61832-B.)

mechanism at a distance is given a pulse of current that moves a pointer and/or a pen to the same extent, and in the same direction, as the two contacts moved in the transmitting apparatus. The Museum has a receiving instrument, MHT 316,815, that both indicates on a dial and records on a drum, and also a transmitter, MHT 314,564, with a Bourdon-tube thermometer. The two are shown in figure 51.

Somewhat later than the Bourdon tube, the bimetal was applied to a simple recording thermometer, with the advantage of faster response.

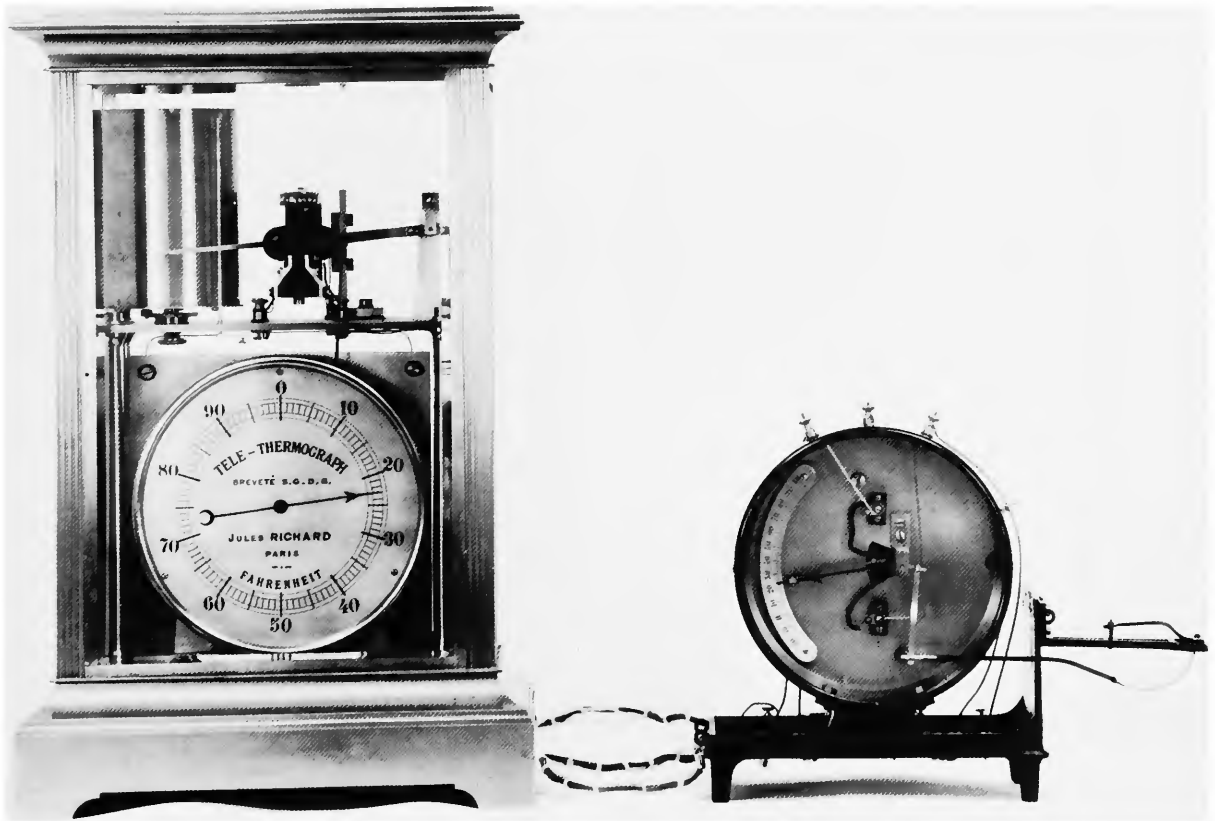

FIGURE 51

Receiving instrument and transmitter.

MHT 316,815. Receiving portion of the telethermograph. The 19-cm dial is marked "Tele-thermograph Breveté S.G.D.G. Jules Richard Paris Fahrenheit," and is graduated from 0° to 90°. In the upper part of the instrument there is a pen arm coupled to the mechanism that drives the pointer in front of the dial, and also a recording drum of the standard Richard type. Overall dimensions, 34 x 25 x 52 cm. Transferred from the Weather Bureau in 1959.

MHT 314,564. Transmitting portion of a Richard Frères telethermograph. This consists of the mechanical parts of a standard Richard thermograph with a Bourdon tube 7 cm long and 3.2 cm wide, but instead of a pen arm there is a rod ending in a contact spring. The remainder of the mechanism, including electromagnets and ratchet arrangement, is in a black metal box 18.5 cm in diameter and 5 cm deep. Overall dimensions, 34 x 26 x 16 cm. Transferred from the Weather Bureau in 1954. (Smithsonian photo 61903-C.)



FIGURE 52

MHT 317,478. Negretti and Zambra's "recording thermometer." A U-shaped thermometer on an ebonite base 25 x 3.4 x 0.6 cm. Cylindrical bulb; tube with constriction near bulb, next a tube graduated 0 to 125 [°F], then a U bend. Beyond the bend the tube has a finer bore and is graduated 15 to 120. The numbers for both scales and the legend "Negretti & Zambra's Patent" are on a piece of white-flashed glass 17 x 1.2 x 0.2 cm lying between the branches of the tube. The tube is marked "Patent no. 28" and the base "Negretti & Zambra London" and "Recording Thermometer." It is to be installed vertical, bulb down. The temperature at any time can be indicated for future reference by simply rotating the thermometer one revolution counterclockwise, when the thread of mercury will break off and run into the second tube. It is reset by giving it one turn clockwise. A brass shaft, 1.5 x 0.5 cm, projects from the back of the mounting. Transferred from the Weather Bureau in 1960. (Smithsonian photo 61900-B.)

The Museum has a specimen from which the manufacturer's nameplate has been lost (MHT 317,484).

MHT 317,484. Bimetallic thermograph. A pen arm is mounted on a gate attached directly to the axis of a helical bimetal of 5 turns, 2.8 cm in diameter. The pen records on a standard drum 9.3 cm in diameter and 9.2 cm high, containing a seven-day clock. The base and left-hand end are cast; the remainder of the case, 18 x 13 x 16 cm, is of sheet metal with a glazed window in front. The nameplate is missing, but the instrument is similar to those made by Short and Mason in England. Transferred from the Weather Bureau in 1960.

We shall end with a reference to a thermometer that can be made to indicate the temperature that prevailed at the instant when it was rotated counterclockwise through one revolution in its own plane.¹⁰² One of two examples in the Museum is MHT 317,478, shown in figure 52. This was originally conceived as a deep-sea thermometer. Negretti and Zambra's suggestion for its application to meteorology is shown in figure 53, which shows eight of these thermometers arranged to be released by a clock at 3-hour intervals.

¹⁰² *Negretti & Zambra's Encyclopaedic . . . Reference Catalogue . . .* (London, n.d., but ca. 1886), pp. 101-3.

NEGRETTI AND ZAMBRA'S PATENT APPARATUS FOR RECORDING HOURLY TEMPERATURES.

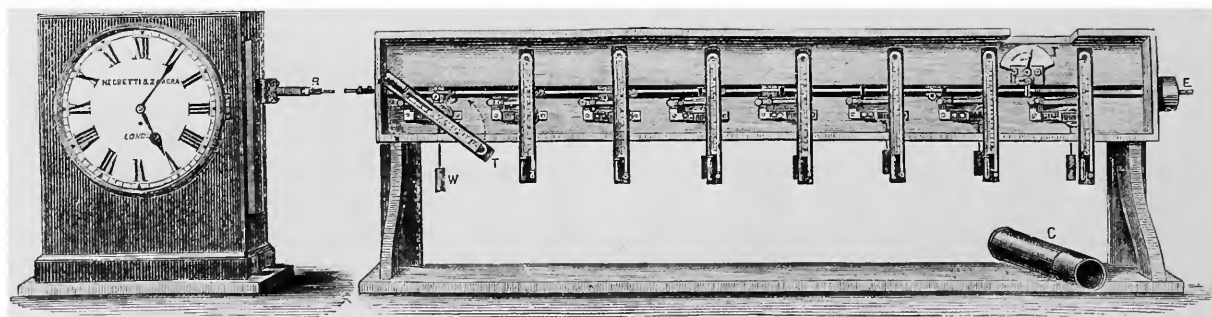

FIGURE 53

Array of eight thermometers to record the temperature at three-hour intervals. (Smithsonian photo 63210.)

Instruments not Referred to in the Text

Like many other museums, the Museum of History and Technology contains a disproportionate number of thermometers in its meteorological collection. Many of these differ only in unimportant respects from instruments that have been described above, and to avoid unbalancing the catalog, these will have only brief reference here.

230,005. Maximum thermometer on metal mount marked "H. J. Green B'klyn. N.Y. N^o 9746 U.S. Weather Bureau." Length 31 cm. Transferred from the Weather Bureau in 1904.

230,006. Minimum thermometer, Rutherford type, on metal mount, marked "H. J. Green B'klyn. N.Y. N^o 7390 U.S. Weather Bureau Minimum." Length 31 cm. Transferred from the Weather Bureau in 1904.

308,156. Household thermometer with red spirit and lens front to make the spirit column look wider. Tube mounted on silvered-brass plate carrying scale, -20 to $+116^{\circ}$ F in 2-degree intervals. "Freezing" opposite 32, "Temperate" opposite 56, "Sumr Heat" opposite 76, and "Blood Heat" opposite 98. Brass guard for spherical bulb. All on varnished oak base $22 \times 5.2 \times 0.9$ cm with hanging ring. Plate marked "Taylor Bro's Rochester N.Y." and trademark. Presented by the Taylor Instrument Companies.

308,157. Household spirit thermometer, similar to 308,156 except for color of mount and extent of scale, marked "Tycos Rochester, N.Y. U.S.A. Toronto, Canada."

308,196. Mercury-in-glass thermometer, with a cylindrical bulb (blown from the tube, which has a white glass strip). Scale -10 to $+68$ [$^{\circ}$ C]. Tube marked "Etabl^{ts} Poulenc Fils Paris." Length 17 cm. Apparently used during World War I by the Meteorological Service of the American Expeditionary Forces. Transferred by the Signal Corps in 1923.

308,197. Mercury-in-glass thermometer, on a metal base $24 \times 2.3 \times 0.2$ cm, formed with a groove, and marked "Schneider Bros N^o 7293." The scale, -35 to $+130$ $^{\circ}$ F, is marked on the tube, the numbers and the major divisions repeated on the base. Transferred from the Signal Corps in 1923.

308,199. Maximum and minimum thermometers on Townsend support, similar to 308,198 except that the thermometers are numbered 36061 and 41530 respectively. Transferred from the Signal Corps in 1923.

314,534. "Kiosk" thermometer, mercury-in-glass, last 10 cm bent backwards and going through a hole in the metal plate, which measures 40×5 cm. Cylindrical bulb 4.5×1.0 cm. Bears the Number "U.S. No. 2," but in other details is the same as MHT 314,533. Transferred from the Weather Bureau in 1954.

314,554. Exactly the same as MHT 317,478, except that the brass bearing is missing, and the tube is marked "Negretti & Zambra's Patent, 62." Transferred from the Weather Bureau in 1954.

314,555. Alcohol-in-glass thermometer, with its tube, graduated from -70 to $+113$ [$^{\circ}$ F], mounted on a silvered (much corroded) flat metal plate $20 \times 2.4 \times 0.15$ cm. The cylindrical bulb and 1 cm of the tube project below the plate. Numbers and main divisions on white glass strip beside tube. Tube marked "U.S. 2352." Plate marked "H. J. Green N.Y. No. 2352 Signal Service U.S. Army." Transferred from the Weather Bureau in 1954.

314,557. Mercury-in-glass thermometer for measuring temperatures near the surface of water. A mercury thermometer, graduated on the stem from 21 to 50° F in fifths, is suspended in a mounting of wood and brass, the lower part of which forms a cup 4 cm long and 2.5 cm diameter, surrounding the bulb. A helical spring has one end attached to the bottom of this cup as a shock absorber. At the top end the mounting is completed by a brass ferrule and hanging ring. Total length 29.5 cm. Transferred from the Weather Bureau in 1954.

314,870. Pair of thermometers, maximum and minimum, each on a metal back 31×2.2 cm, the whole mounted on a mahogany board $34 \times 9 \times 1.3$ cm, the spherical bulbs covered with a protective metal strip. The maximum thermometer is marked "No. 90162 Henry J. Green B'klyn. N.Y. Maximum." The minimum "Taylor Rochester, N.Y. No. [blank] Minimum" and on the stem "U.S. 242382". Deposited by the Smithsonian Astrophysical Observatory in 1956.

315,808. Six small resistance-thermometer elements in steel casings with plastic terminal boxes, overall lengths 10 and 7.5 cm; also a vial containing the disassembled elements of a seventh instrument. These thermometers, developed by George F. Taylor for micrometeorological studies, were patented (U.S. Patent 1,490,990) and described in the *Physical Review*, vol. 26 (1924) pp. 841–50. “Each element consists of a lead filament 1.5 cm long and 2×10^{-3} mm in diameter in a glass tube 4×10^{-5} mm thick, embedded in a type metal which makes contact with one end of the filament. . . . The resistance of the filament is 448 ohms so that with a portable galvanometer a sensitivity of .005° is readily obtained. The temperature lag is about 10 sec.”¹⁰³ Presented in 1958 by Mr George F. Taylor of Grosse Point Woods, Michigan.

315,811. Alcohol-in-glass thermometer 31 cm long with a tube having a white glass back. Graduated in half degrees from [—] 80 to 0. Marked “Henry J. Green, B’klyn, N.Y. No. 8067.” Deposited by the Smithsonian Astrophysical Observatory in 1958.

315,812. Mercury thermometer 30 cm long with a spherical bulb and a scale, not numbered, but having 85 divisions. The tube bears the number 89,593, but is unsigned. It is evidently intended for use on a mount bearing the numbers. Deposited by the Smithsonian Astrophysical Observatory in 1958.

316,003. Mercury-in-glass thermometer with a blackened bulb, 1.0 cm diameter, and a tube with milk-glass back, 35 cm long; scale in °C, 10° to 60° in 0.1° divisions. Marked “J. & H. J. Green, N.Y. No. 4571.” Deposited by the Smithsonian Astrophysical Observatory in 1958.

316,009. Mercury-in-glass thermometer, graduated from –20.0 to +74.8 [°C] in fifths, and bearing the legend “Tub. non Cyl. div. rectific. syst. Baudin (1881.3).” The bulb cannot be seen for it is inside a copper ball about 5 cm in diameter, with a roughly sealed glass tube projecting 7.5 cm in the direction opposite to the thermometer tube. Probably a research apparatus. Deposited by the Smithsonian Astrophysical Observatory in 1958.

316,084. Alcohol-in-glass thermometer, minimum, Rutherford type, on flat brass mount 30.5 x 2.2 x 0.15 cm, with hole 1.6 cm diameter beneath the 1.2 cm

spherical bulb. Scale, –72 to +117 [°F], divided on the tube and numbered on a white-glass strip. The tube has a white-glass background. Bulb blown from clear glass. On the mount: “N^o 7742 Henry J. Green B’klyn. N.Y.” Deposited by the Smithsonian Astrophysical Observatory in 1959.

Thermometers numbered 316,155 to 316,286, inclusive, were transferred from the Weather Bureau in 1959.

316,155. A wooden box 39 x 21 x 18 cm, containing thermometers filled with various liquids, used at Fort Conger on the Lady Franklin Bay polar expedition in 1881–83,¹⁰⁴ in order to determine the relative merits of alcohol, carbon disulphide, and ether at temperatures below –40° F. Six of the thermometers are Rutherford-type minimum thermometers of uniform pattern, about 42 cm long, with spherical bulbs 1.5 to 2.0 cm in diameter, blown from the tubes with their white-glass strips. The scales are engraved in millimeters on the tubes, and numbered on an adjacent brass scale, from 0 up to 250. Each has a Signal Service number: Numbers 2 and 4 are stated to be filled with ether, numbers 6 and 8 with carbon disulphide, and numbers 10 and 12 with ether. A typical inscription is: “J. & H. J. Green N.Y. Yale Min. Std. May 1881. Corning glass. Squibbs ether. Signal Service U.S. Army. N^o 2.” Each is mounted in a hinged pine box 34 x 3 x 4 cm, with a hole to expose the bulb. Two ordinary spirit thermometers and the remains of another are attached to grooves in three sides of a wooden block; a fourth seems to have disappeared. All were made by J. & H. J. Green, and have flat metal mounts. One, Signal Service number 708, has a spherical bulb; another, number 1010, a cylindrical bulb. Number 708 is graduated, on the mount only, from –73 to +132 [°F]; number 1010 from –67 to +123°.

316,271. Transmitting apparatus, incomplete, of a telethermograph. By means of a linkage, sector, and

¹⁰⁴ See Adolphus W. Greely, *Three Years of Arctic Service. An account of the Lady Franklin Bay Expedition of 1881–84* . . . (New York, 1886), vol. 1, p. 125. “Some excellent standard thermometers, of bisulphide of carbon, pure spirits of wine, and ether, were made for the expedition, under the careful supervision of Professor Waldo of Yale College Observatory. They were graduated in millimetres arbitrarily. . . .”

¹⁰³ *Physical Review*, vol. 26 (1924), p. 841.

pinion, a Bourdon tube moves a pointer which is bracketed by two contacts (missing) carried by a shaft driven by a reversing motor. The apparatus, made largely of brass, is covered by a copper case 23 x 20 x 22 cm, and is on a mahogany base 24 x 22 cm. The Bourdon tube, 7 x 3.3 cm, is freely exposed outside the case. On the case is the inscription "Télé-thermographe Breveté S.G.D.G. Jules Richard Constructeur Paris"; on the instrument, "Richard Frères Constructeurs brevetés Paris" and the trademark of the firm. (See also MHT 314,564, figure 51.)

316,277. Two Russian enclosed-scale thermometers, each 36 cm long. The white-glass scale of one (number 1087) is loose. Number 1087 is graduated in fifths from -12.0 to $+39.0^{\circ}$ C and number 1114 from -11.0 to $+37.0^{\circ}$ C. Each marked with a monogram and "оцт 40172."

316,278. Russian enclosed-scale thermometer, mercury-in-glass, 36 cm long and 1.7 cm in diameter. Milk-glass scale, held in glass at the bottom, and by a cork at the top. Graduated -35° to $+84^{\circ}$ C in half-degrees. Marked "4277" on front of scale and "оцт 40178" on back.

316,279. Russian enclosed-scale mercury-in-glass thermometer, 42 cm long. Graduated in fifths, -32° to $+43^{\circ}$ C on white-glass scale. Bulb roughly spherical. Scale bears number "98" and works mark "оцт 40180." Outer tube has "538423" and a monogram etched on it. Heavy nicked cap at end opposite bulb.

316,280. Russian enclosed-scale thermometer, 42 cm long, similar to 316,279 except that the scale (which is broken) is graduated from -29 to $+41^{\circ}$ C. Numbered "153" on scale and "538454" on tube.

316,281. Russian enclosed-scale maximum thermometer, 34 cm long, with constriction. The enclosed milk-glass scale is broken. Scale in half-degrees C from -30 to $+74^{\circ}$. Front of scale marked "Максимальный" and back "оцт 40177."

316,282. A pair of Russian enclosed-scale thermometers, 39 cm long, graduated on white glass from -82 to $+25^{\circ}$ C, in half degrees. Cylindrical bulbs only about 1.8 x 0.6 cm filled with clear alcohol. Bear the numbers "327740" and "327800" etched on the outer tube.

316,283. Russian enclosed-scale minimum thermometer, 35 cm long, Rutherford type, with slender

black-glass index 1.2 cm long. Scale -56° to $+22^{\circ}$ C in half degrees. Marked "Минимальный" and "693" on front and "оцт 40179" on back.

316,285. Russian sling thermometer, scale -31° C to $+45^{\circ}$ C in half-degrees on white-glass-backed tube, marked "N 958 Гост 381-41." 19 cm long, with cylindrical bulb. A string 60 cm long is attached to a glass knob at the end of the tube. The instrument is accompanied by a calibration sheet, a printed form.

316,286. Two Russian enclosed-scale mercury-in-glass thermometers 22 cm long. The white-glass scale of one is broken. Each is graduated in fifths from -4.6 to $+41.0^{\circ}$ C. They bear the numbers "5209" and "5229" on the scales, and "Гост N 59-40" etched on the protecting tubes.

316,450. Mercury-in-glass thermometer, 20 cm long, with a cylindrical bulb 3.8 cm long and 0.7 cm in diameter. The scale, intended for the measurement of the boiling point of water, and hence of the atmospheric pressure, is from 208 to 218 $^{\circ}$ F in tenths of a degree. The tube has a white-glass back, marked "Palo Co. N.Y."

316,452. Mercury-in-glass thermometer with a tube 11 cm long and a spherical bulb 0.8 cm diameter, scale on a slip of ivory, 183 $^{\circ}$ to 247 $^{\circ}$ [F?]. Marked "J. Green N.Y." Transferred from the U.S. Military Academy in 1959.

Thermometers numbered 317,443 to 317,475 inclusive were transferred from the Weather Bureau in 1960. Of these, numbers 317,443 to 317,453 are thermometers that were most probably used as standards at one time or another for the calibration or testing of meteorological thermometers.

317,443. Mercury-in-glass thermometer 31 cm long, having a cylindrical bulb 0.5 cm in diameter. The tube has a white-glass back strip, marked "J. & H. J. Green, N.Y. No. 734." The scale, -40 to $+125^{\circ}$ F, is etched on the tube.

317,444. Mercury-in-glass thermometer 32 cm long, with a spherical bulb 0.8 cm in diameter, and a scale in half-degrees from -15.5 to $+75^{\circ}$ C etched on the tube, which has a white-glass strip and is marked "L. Golaz à Paris. Centigrade. 729."

317,445. Mercury-in-glass thermometer 38 cm long, with a cylindrical bulb. The scale, -25 to $+130^{\circ}$ F, is etched on the tube, which has a white-glass back strip, marked "L. Casella. London. 14490."

317,446. Almost exactly like MHT 317,444 above, except that it bears the number "725" and that the scale is graduated from -14 to $+69^{\circ}$ C.

317,447. Mercury-in-glass thermometer 63 cm long with a cylindrical bulb. The scale, in fifths of a degree from -15 to $+41$ [$^{\circ}$ C] is etched on the tube, which has a white-glass strip. Calibration marks at 0° and 36.08° . Marked "J. Hicks. 8 Hatton Garden, London. 207446."

317,448. Mercury-in-glass thermometer 46 cm long with a cylindrical bulb. The scale, -40 to $+140^{\circ}$ F, is etched on the tube, which has a white-glass strip. Marked "Hicks' Patent No. 4434," and "J. Hicks, 8 Hatton Garden London. N $^{\circ}$ 217122." In brass case.

317,449. Mercury-in-glass thermometer 64 cm long, with a clear-glass tube less than 0.5 cm in diameter, and a cylindrical bulb. Scale in fifths of a degree from -10.2 to $+108.0$ [$^{\circ}$ C]. Red graduations and figures. Marked "Tonnelot à Paris. (1884.5) 4289."

317,450. Spirit-in-glass thermometer 52 cm long, having a cylindrical bulb 5 x 0.8 cm, and a tube with a white glass strip. Scale, -65 to $+150^{\circ}$ F, etched on tube. Marked "J. Hicks 8 Hatton Garden London, —N $^{\circ}$ 217967—."

317,453. Spirit-in-glass thermometer 51 cm long, having a cylindrical bulb; scale in fifths of a degree, -70 to $+30^{\circ}$ C, etched on tube with milk-glass strip. Marked "Thermomètre Baudin No. 15774 gradué d'après l'Echelle Normale Internationale (1902.9)." Large safety bulb at top of tube.

317,454. Mercury-in-glass thermometer 26 cm long. Enclosed rolled-paper scale, -16 to $+60^{\circ}$ C. Cylindrical bulb. Marked on paper scale "No. 6563 U. S. W. B. Phila. Thermo. Co."

317,458. Mercury-in-glass thermometer 17 cm long; cylindrical bulb 0.5 cm diameter, tube with milk-glass strip, bulb blown directly from this; scale -32° to $+43^{\circ}$. Marked "Centigrade, 699. J. Salleron, 24 rue Pavée (au Marais) Paris."

317,460. Minimum thermometer of the Rutherford type, 26 cm long; spherical bulb 1.8 cm in diameter. Tube with milk-glass strip, with the scale etched on

it, -68° to $+127^{\circ}$ [F]. The bulb blown directly from the tube, with the strip. No other markings.

317,462. Minimum thermometer of the Rutherford type, with very small cylindrical bulb, only about 1.9 x 0.5 cm, and very fine tube and dumbbell index. Length 29 cm, bulb projecting 3.5 cm beyond metal mounting with formed groove. Scale -39 to $+110$ [$^{\circ}$ F] on tube, numbers and major divisions repeated on mounting. Tube marked "U.S. 8727." Mounting marked "H. J. Green B'klyn. N.Y. N $^{\circ}$ 8727 U.S. Weather Bureau" and "Minimum."

317,463. Spirit-in-glass minimum thermometer, length 30 cm. The bulb, 4.5 x 0.5 cm, projects 5.5 cm beyond the flat brass mounting, 24 x 2.3 x 0.15 cm. It is a minimum thermometer with a conical frustum 5.5 cm long, the larger end farther from the bulb, the "tail" very narrow, behind the usual dumbbell-shaped index. Scale, -92 to $+97$ [$^{\circ}$ F] on the tube, with numbers and major divisions on an adjacent white-glass slip. Tube marked "No. 1868 Signal Service U.S. Army." On the mounting "1868 Henry J. Green New York."

317,464. Thermometer similar to 317,463 except that the metal mounting is extended, with an oval cutout, past the bulb. Scale -90 to $+80$ [$^{\circ}$ F]. Markings: on tube, "No. 1924 Signal Service, U.S. Army"; on mounting, "1924 Henry J. Green New York."

317,465. Minimum thermometer of the Rutherford type on a flat brass mount 30 x 2.3 x 0.15 cm. Scale graduated on tube and numbered in tens on adjacent strip of white glass, -35 to $+122$ [$^{\circ}$ F]. Tube marked "U.S. 1483." Mounting engraved "N $^{\circ}$ 1483 Signal Service U.S. Army. JA $^{\circ}$ Green New York." The bulb of this thermometer, 1.1 cm in diameter, was blown from the tube, with its white-glass strip.

317,467. Minimum thermometer of the Rutherford type, 30 cm long, with a spherical bulb 1.6 cm in diameter; scale -95 to $+135^{\circ}$ [F] on the tube, which has a milk-glass strip. Marked "J. & H. J. Green, N.Y. Signal Service U.S. Army No. 14." Probably had a base, now missing.

317,468. Minimum thermometer of the Rutherford type, 26 cm long. The scale, from -40 to $+100^{\circ}$ F is engraved on the tube, which has a white-glass back strip. No other markings. The liquid with which it is filled is slightly yellow. This has almost certainly had a mounting at some time.

317,469. Minimum thermometer of the Rutherford type, 32 cm long, scale -20 to $+130$ [$^{\circ}\text{F}$]. Dumbbell index 1.5 cm long. Cylindrical bulb. Scale etched on tube, which has milk-glass insert. Marked "Patent N $^{\circ}$ 4434 [Kew Observatory monogram] 10085 N $^{\circ}$ 84120."

317,470. Minimum thermometer of the Rutherford type, 30 cm long, with 1.9 cm spherical bulb. Scale, -22 to $+112$ [$^{\circ}\text{F}$] etched on tube, numbers and main divisions on white porcelain plate 24 x 3.7 cm, surrounded by heavy mahogany frame, with 2 hanging rings and brass guard for bulb. Porcelain plate inscribed "M.O. [monogram] 24 Negretti & Zambra, Scientific Inst t Makers, London" and N & Z monogram. Overall length, 34.5 cm.

317,471. Spirit-in-glass minimum thermometer, almost identical with 317,470, except that it is marked "M.O. [monogram] 575 J. Hicks, 8, 9, & 10. Hatton Garden London."

317,472. Maximum thermometer with constriction; 26 cm long; cylindrical bulb; scale $0-100^{\circ}$ F engraved on glass tube with milk-glass strip. Marked "Maximum Phila. Thermo. Co. 31507."

317,473. Maximim thermometer to U.S. Weather Bureau specification. Similar to 317,474 below, except that the scale goes from -30 to $+110$ [$^{\circ}\text{F}$]; the tube is marked "US 43191"; and the mounting "Taylor Rochester N.Y. U.S.W.B. No. 43191 Maximum."

317,474. Maximum thermometer with constricted tube, mounted on metal (stainless steel?) plate 30.4 x 2.3 x 0.2 cm, with formed groove. Spherical bulb, 1.2 cm in diameter. Scale on tube -29 to $+57$ [$^{\circ}\text{C}$?]; major divisions and numbers also on mounting. Tube marked "U.S. 12701." Mounting marked "H. J. Green B'klyn. N.Y. N $^{\circ}$ 12701 U.S. Weather Bureau. Maximum." Bearing, brass, for about 0.5 cm, shaft is screwed to mounting at end remote from bulb.

317,475. Maximum thermometer, 30 cm long, with constriction, in a wooden frame with white porcelain plate behind the tube, and a brass guard for the cylindrical bulb. Scale on tube, from -50 to $+125$ [$^{\circ}\text{F}$]; figures and main divisions on porcelain plate, which carries the notation "B 22580 Negretti & Zambra, London" and their monogram.

322,607. A minimum thermometer of the Rutherford type, made by "Dr H Geissler in Bonn." It is an

enclosed-scale thermometer with a milk-glass scale inside a glass tube 2 cm in diameter. The total length including the brass cap is 42 cm. It is graduated in fifths of a degree C from -39 to $+49^{\circ}$. The bulb is forked, with two prongs each 4 cm long and 7 mm diameter. Presented by Western Reserve University in 1963.

322,751. Reproduction of the famous helical thermometer described in the *Saggi* and existing in the *Museo di Storia della Scienza* at Florence. Overall height 35 cm, diameter 11 cm. Received in 1963.

322,754. Reproduction of the thermoscope traditionally ascribed to Galileo. Identical with MHT 322,752 (figure 30).

322,764. Mercury-in-glass thermometer with spherical bulb 1.0 cm in diameter, painted black. The tube has a white-glass back, and is marked "Tub non cyl div. rectific. syst. Baudin (1881.8) Centigrade 9014." The scale is from -20.0° to 70.4° C in fifths. The instrument is 36 cm long, and is in a cylindrical brass case. Provenance unknown.

326,555. Maximum thermometer of the Phillips type, two small air bubbles near bulb. Thermometer 30 cm long, with spherical bulb, mounted on a porcelain base 29 x 4.3 x 0.5 cm, the whole on an oak base 35 x 5.5 x 1.3 cm, with a hole behind the bulb and a semicircular brass guard over it. Scale on tube, -4 to $+127$ [$^{\circ}\text{F}$]; figures on porcelain base, which is marked "Maximum L. Casella. Maker to the Admiralty, London N $^{\circ}$ 9714." Provenance unknown.

326,942. Simplified Six's maximum-and-minimum thermometer in a black molded-plastic frame 29 cm long and 6 cm wide, the actual tube being attached to a blackened metal plate bearing white numbers and the main graduations, as well as the words "Cold," "Heat," and "Taylor Rochester, N.Y. U.S.A." The maximum graduated from -10 to $+130$ [$^{\circ}\text{F}$], the minimum from -40 to $+110$, on the lens-fronted tube. Transferred from the District of Columbia Public Schools in 1965.

327,549. Minimum thermometer of the Rutherford type, with its tube bent down near the spherical bulb, mounted in a wooden frame with two rings for hanging. In this is set a white-glass plate 18 x 5 cm bearing the scale, -35 to $+50^{\circ}$ C, and the inscription "Thermometer minima nach Celsius." Overall length, 29 cm. Presented in 1966 by Union College, Schenectady, New York.

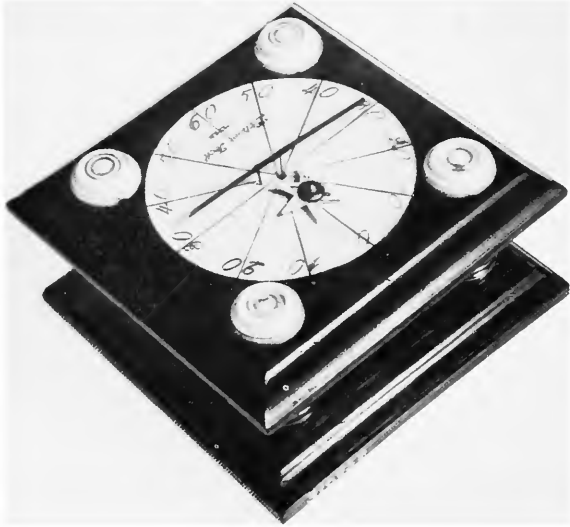
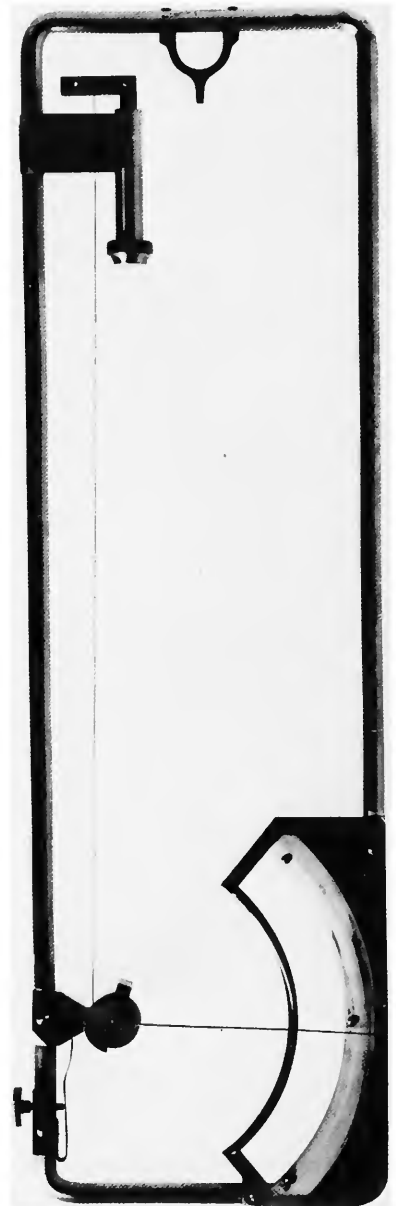

FIGURE 54

MHT 316,858. Reproduction of the oat-beard hygrometer, about 10 cm square and 5 cm high, based on the illustration in the *Micrographia* of Robert Hooke. In this instrument the pointer also carries a small vertical appendage projecting downward that engages the teeth of a star wheel and counts the number of revolutions made by the pointer. Marked "Eichner Fecit MCMLIX." Received in 1959. (Smithsonian photo 61901-A.)

FIGURE 55

MHT 314,542. A 19th-century copy, fairly close in general appearance, of H. B. de Saussure's original hair hygrometer, second model; instead of a weight to keep the hair extended, this has a fine hairspring. The frame, 32.5 x 9.4 cm, is rather elaborately supported in a mahogany box, 40 x 17 x 11 cm, of which the glazed front and the two longer sides can be opened on hinges. The pointer moves over a silver quadrant fastened by three screws to a brass plate, but the scale, 0 to 100, is engraved on the latter. There is no maker's name. Transferred from the Weather Bureau in 1954. (Smithsonian photo 61901-B.)



Chapter 4

Instruments for the Measurement Of Atmospheric Humidity

The measurement of the amount of water vapor in the atmosphere can be made in several distinct ways, so that there are at least six classes of instruments that might appear in this chapter. Three of these are represented in the collection:

- Those depending on the absorption of water vapor by solid substances.
- Those making use of the condensation of water on a cooled surface.
- Those depending on the cooling produced by the evaporation of water.

There are also chemical, electrical, and optical hygrometers, of which only the electrical, which will be mentioned in chapter 10, have been used to any extent in meteorology.

Absorption hygrometers

It occurred to both Leon Battista Alberti¹⁰⁵ and Nicolaus of Cues¹⁰⁶ in the 15th century that if some water-absorbing substance was placed

on one end of a balance beam, the balance would vary its equilibrium as its load absorbed more or less water from the atmosphere. Alberti used a sponge; Nicolaus used wool.

In the succeeding centuries, the changes in dimensions of various organic substances came to be preferred to changes in weight. By 1554 Antoine Mizauld related the change in the length of gut strings to the changes in the air.¹⁰⁷ Dozens of hygrosopes, many of them fantastic, were described in the 17th and 18th centuries, making use of various animal and vegetable substances and even porous stone.¹⁰⁸ Of all those invented before about 1780, the best known is the “oat-beard hygrometer” usually ascribed to Robert Hooke, but certainly known to Emmanuel Maignan in 1648.¹⁰⁹ Hooke’s instru-

¹⁰⁵ Alberti, *De re aedificatoria* (Florence, 1485), Book 10, chapter 3.

¹⁰⁶ Nicolaus [Khrypffs] of Cues, *Opera* (Basle, 1565), p. 176. This was written about 1450.

¹⁰⁷ Mizauld, *Ephemerides aeris perpetuae* . . . (Paris, 1554) p. 49.

¹⁰⁸ Some account of these will be found in W. E. K. Middleton, *The invention of the meteorological instruments* (Baltimore: The Johns Hopkins Press, 1968), pp. 85–102.

¹⁰⁹ Maignan to Prince Leopold of Tuscany, from Rome, July 18, 1648. Florence, Bibl. Naz., ms. Gal. 275, fol. 16.



FIGURE 56

MHT 314,527. Lambrecht's hair hygrometer. In a brass case 13.5 cm in diameter and 4.2 cm thick, with many perforations round the sides, is mounted a bundle of hairs attached to a weighted lever arm on an axis which carries a pointer moving in front of a scale graduated non-uniformly from 0 percent to 100 percent (relative humidity). The white card that carries the scale is printed with the monogram of Wilhelm Lambrecht and also "U.S. W.B. 87. Lambrecht's Hygrometer. Percentage of Humidity." Transferred from the Weather Bureau in 1954. (Smithsonian photo 61900-C.)

ment¹¹⁰ has an elementary revolution counter, as in the reproduction (MHT 316,858) shown in figure 54, because the awn of the wild oat seed could make several turns.

The only absorption hygrometer that has had wide use in meteorology is the hair hygrometer, first described in 1783 by Horace Benedict de Saussure (1740–1799) of Geneva.¹¹¹ The Museum

has a 19th-century hair hygrometer (MHT 314,542) that looks very like De Saussure's original smaller model, and is shown in figure 55. Many modifications of the original models have been made, some in De Saussure's lifetime. One modification was to use bundles of hair, as in MHT 314,528, it being felt that the single hair was too fragile; or "harps" in which several hairs were kept parallel by being attached to a wide clamp at each end (MHT 314,536). Both these schemes are stronger than the single hair, but raise the difficulty of ensuring that all the hairs are under the same small tension.

MHT 314,528. Hygrometer, designed by Professor C. F. Marvin in 1908, which adds the changes of length of two bundles of hair, each 16 cm long. These are carried in a housing formed by four rods, extending behind a flat cylindrical brass box 15 cm diameter x 2.5 cm thick, having a glass front which shows the pointer and a silvered scale reading 0 to 100 and marked "Percentage of saturation [relative humidity] Hair Hygrometer N^o 19 U.S. Weather Bureau. Henry J. Green, B'klyn. N.Y." Transferred from the Weather Bureau in 1954.

MHT 314,536. Hair hygrometer with two "harps" of hair each 17 cm long (one now broken), their changes in length added by a lever at the top, and communicated to the pointer shaft by a lever of adjustable length. Scale covering an arc of about 60 degrees, graduated 0 to 100. Frame marked "U.S. Weather Bureau. N^o 22 H. J. Green B'klyn. N.Y." Transferred from the Weather Bureau in 1954.

In the last decades of the 19th century, Wilhelm Lambrecht made large numbers of simple hair hygrometers—especially for household use—of which MHT 314,527, figure 56, is an example. He also combined it with a liquid-in-glass thermometer, calling the result a "Polymer," because the dew point and the vapor pressure could be derived from the results.¹¹²

¹¹⁰ *Micrographia* . . . (London, 1665), pp. 149–51.

¹¹¹ De Saussure, *Essais sur l'hygrométrie* (Neuchâtel 1783).

¹¹² See Julien P. Friez, *Illustrated Catalogue of Meteorological Instruments and Apparatus* . . . (Baltimore, 1893), pp. 35–37.



FIGURE 57

MHT 316,597. Draper's hair hygrometer. It records on a flat circular chart, 31 cm in diameter, revolved once in seven days by a clock. Inside the case, a flat bundle of hairs passes partly round a brass cylindrical sector on the same shaft as a pen arm. A small weight keeps the hairs extended. On the cast front of the case is the legend "Draper's Self-recording Hygrometer Pat. Appld for. The Draper Mfg. Co. 152 Front St. N.Y." Deposited by the Freer Gallery of Art in 1959. (Smithsonian photo 61907-D.)

The Museum has an incomplete example (MHT 314,562).

MHT 314,562. Hair hygrometer in a form widely distributed by Wilhelm Lambrecht of Göttingen; damaged and incomplete. A frame of two brass plates 24 x 2 cm, spaced 0.7 cm apart, held a bundle of hairs, now missing. Near the



FIGURE 58

MHT 327,634. Hair hygrometer similar to those under MHT 308,178, but in mint condition. The cover bears the label "Hygrograph SOFNJ No. 2133 Julien P. Friez & Sons Baltimore Md. U.S.A." It is finished in glossy dark-brown enamel, the mechanical parts are of lacquered brass. Presented in 1966 by Rutgers University, New Brunswick, New Jersey. (Smithsonian photo 61907-B.)

bottom of the frame is a brass box 7.5 cm in diameter x 1.2 cm thick, with a glass front and a white dial. The dial carries scales of relative humidity and depression of the dew point, also instructions for the (very approximate) determination of the dew point, and is marked "Julien P. Friez Meteorological Instruments [*sic*] and Apparatus Baltimore (Md.) U.S.A. Lambrecht's Polymeter." There are clips to hold a thermometer, which is missing. Transferred from the Weather Bureau in 1954.

The hair hygrometer lends itself to making a record. Probably the earliest hair hygrometer in the collection is that designed about 1887 by Daniel Draper, at one time director of the Central Park Observatory in New York City. This is MHT 316,597, and is shown in figure 57.

A more sophisticated approach was taken by Richard Frères of Paris, who added a hair hygrometer to their line after experimenting with goldbeater's skin and with horn. This firm believed it to be important to have a linear scale of relative humidity, and achieved this result by means of two cams, at the expense of some frictional resistance. The Richard Frères design was later made in the United States by Julien Friez, and the Museum has three of these, two under the number MHT 308,178.

MHT 308,178. Two hair hygrometers, neither quite complete. These are of the type in which the bundle of hair, 19 cm long, is mounted transversely to the plane of the lever system, and a system of cams is used to make the scale linear in relative humidity. A drum, 9.2 cm diameter x 9.5 cm long, contains a clock, and has a weekly chart. The base, 23 x 13 cm, and right-hand end of the instrument are of cast iron. The cover, 22 x 12 x 13 cm, hinged to the base, is of sheet metal with a glass front and a brass carrying handle. On the cover, "Julien P. Friez & Sons Belfort Meteorological Observatory 1230 E. Baltimore Street, Baltimore, Md., U.S.A." On the base, "Hygrometer Type ML 16 Serial 74865 [on both instruments!] Order 110418 Date 2.8.23". Transferred from the Signal Corps in 1923.

A third, in mint condition, is illustrated in figure 58 (MHT 327,634).

Goldbeater's skin has certain advantages over hair as a material for hygrometers, especially a faster response at low temperatures, though it has not been much used except for upper-air observations in some countries. The Museum has a somewhat damaged hygrometer MHT 317,486, which seems to be an experiment in using goldbeater's skin for this purpose.

MHT 317,486. Hygrometer which appears to have been modified from a standard instrument ("Henry J. Green B'klyn. N.Y. N^o 1039 Type 615 U.S. W. B. N^o. 67," according to the nameplate on the cast-iron base) by substituting for the hair two aluminum rings 5 cm in diameter, between which a sheet of goldbeater's skin (now ruptured) is clamped. The center of this sheet was cemented to two disks of bakelite, 0.95 cm

diameter, attached by a light chain to a lever arm of adjustable length fastened to the axis of the pen arm. The base and case are of the usual standard design and size (see MHT 308,178) adopted by the Signal Corps and the Weather Bureau. Transferred from the Weather Bureau in 1960.

Condensation hygrometers

Not content with inventing the spirit-in-glass thermometer,¹¹³ Ferdinand II of Tuscany also invented a condensation hygrometer, the first of its kind. In this instrument the humidity of the air was measured by noting how much condensed water per hour ran off the tip of a conical vessel filled with ice or snow. The date was about 1655.¹¹⁴ An elegant instrument was developed,¹¹⁵ of which the Museum has a modern replica (MHT 319,467, figure 59). However, this way of measuring humidity was time-consuming and probably very sensitive to the speed of the air past the cone; at all events the Grand Duke's instrument seems to have had no successors. Nearly a century later, while investigating dew at Montpellier, C. Le Roy introduced the concept of the dew point, which he called *degré de saturation*¹¹⁶—the temperature to which a surface has to fall before visible dew begins to condense on it. This is a single-valued function of the amount of moisture in a given volume of the air. The subsequent history of the dew-point hygrometer consists of attempts to provide controllable cooling of a surface and to standardize the conditions of observation.

The most usual means of cooling the surface in the 19th century was by the evaporation of ether. In the well-known hygrometer of J. F. Daniell¹¹⁷ (figure 60) the glass tube and bulbs

¹¹³ See p. 38.

¹¹⁴ The earliest sketch of such an apparatus is probably in Florence, Bibl. Naz., ms. Gal. 259, fol. 13^v.

¹¹⁵ *Saggi di naturali esperienze fatte nell'Accademia del Cimento* (Florence, 1667), plate 1.

¹¹⁶ Le Roy, *Mém. Acad. r. Sci. Paris* (1751), pp. 481–518.

¹¹⁷ Daniell, *Quart. J. Sci.*, vol. 8 (1820), pp. 298–336.



FIGURE 59

MHT 319,467. Reproduction of the condensation hygrometer invented by Archduke Ferdinand II of Tuscany. On a brass tripod is supported a hollow conical frustum of cork, coated with pitch inside and covered on the outside with sheet metal. The cone is continued into a pointed glass vessel, off the end of which condensed moisture could drip into a graduated glass. There is also a drain for the water resulting from the melting of the ice put in the cone. Overall height, 64 cm. Received in 1961. (Smithsonian photo 61902-C.)



FIGURE 60

MHT 318,271. Daniell-type dew-point hygrometer with a gilt band around the lower bulb, to facilitate observation of the dew. The bulbs are about 4.5 cm in diameter, the glass parts 20 cm wide by 21 cm high overall. The internal thermometer has its white-glass scale enclosed, and is graduated from -20 to $+50^{\circ}$ C; the external thermometer, with an open white-glass scale, from -10 to $+50^{\circ}$ C. It is marked "Celsius" and is attached to a turned wooden stand 26 cm high. "Germany" is stamped on the bottom of the turned base. Presented by Cornell University in 1960. (Smithsonian photo 61899-B.)

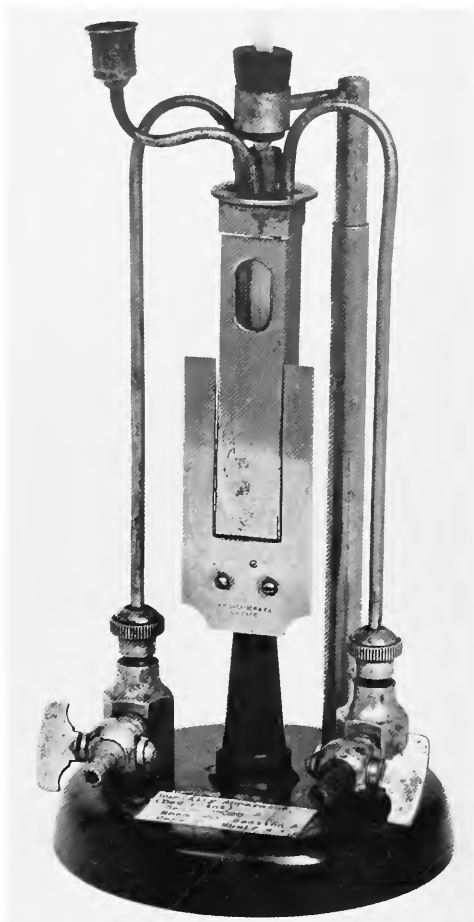

FIGURE 61

MHT 323,821. Alluard's modification of Regnault's dew-point hygrometer. Ether in a square brass tube has air drawn through it to cool the tube so that dew will form. A thermometer in the tube can be observed through glass windows. There are small tubes, with taps, for connection to an air supply and an exhaust. The metal tube is 1.9 cm square x 10 cm high. The overall height of the instrument is 26 cm, and the circular metal base is 11.5 cm in diameter. On the comparison plate surrounding the front surface of the tube is engraved "Wm. Gaertner & Co. Chicago." Presented in 1964 by Kalamazoo College, Kalamazoo, Michigan. (Smithsonian photo 61907-A.)

contain nothing but ether and its vapor. To use it, the instrument is tilted so that most of the ether is in the uncovered bulb; the bulb that is covered with muslin is then moistened with ether from a bottle. The evaporation of this causes the ether in the instrument to distill over, reducing the temperature of the bulb until dew begins to form on its surface. At this moment, the internal thermometer is read. In the Museum's specimen MHT 318,271, there is a gilt band around the bulb, a later improvement.

There are two possible sources of serious error with this instrument. One is the gradient of temperature between the surface of the bulb and the thermometer; however, this error can be greatly reduced by noting the temperature at which the dew disappears, as well as that at which it forms. The other is less tractable and results from the frequent presence of small amounts of water in the ether used to cool the bulb. To get away from this, it is better to evaporate the ether in the chamber that is to be cooled by drawing air through it and discharging the resulting vapor at a distance. The best design for a hygrometer operated in this way is probably that of Alluard,¹¹⁸ represented in the Museum by specimen MHT 323,821 (figure 61), in which a comparison surface, not cooled, surrounds the surface on which the dew is formed.

Psychrometers

The empirical knowledge that a damp surface is cooled by evaporation must be very ancient, but it only begins to be noted in connection with the thermometer about the year 1740.¹¹⁹ It is likely that one of the first to use a moistened bulb to measure the dryness of the atmosphere was the geologist James Hutton (1726–1797).¹²⁰ What was needed was a theory; and this was

¹¹⁸ Alluard, *Journal de Physique*, vol. 7 (1878), pp. 328–30.

¹¹⁹ Cf. G. F. Cigna, *Miscellanea Taurinensia*, vol. 2 (1760), p. 144.

¹²⁰ According to his biographer John Playfair, *Trans. R. Soc. Edinburgh*, vol. 5, part 3 (1805), p. 67, note.

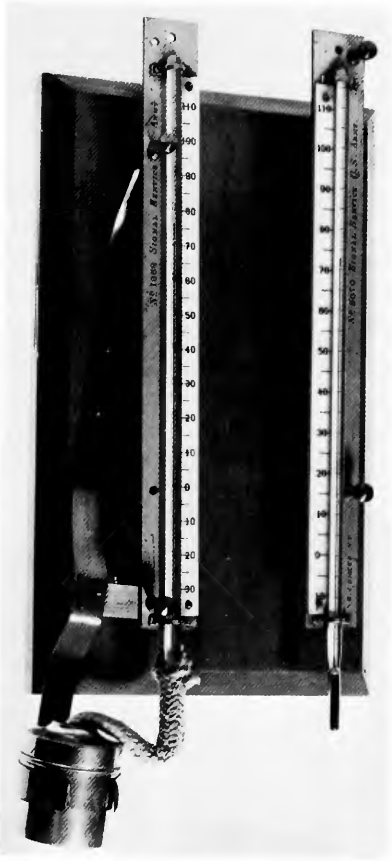

FIGURE 62

MHT 230,007. Psychrometer made for the Signal Service. Two mercury thermometers are mounted on a beveled-edged pine board 25 x 15 x 2 cm. Brass straps bring the thermometers 2.5 cm in front of the board, and the left-hand support has an additional piece holding a nickel-plated waterpot. The thermometers, mercury-in-glass, with cylindrical bulbs, are mounted on flat brass strips 24 x 2.3 x 0.15 cm. Their scales are etched on the tubes, which have white-glass strips drawn in them, and the numbers and main graduations are on adjacent strips of white glass. Thermometer number 1868 also has the tube numbered, and is graduated from -40 to $+118$ [$^{\circ}\text{F}$]. Thermometer number 3070 is graduated from -20 to $+116$ [$^{\circ}\text{F}$]. Besides the numbers, each thermometer is marked "Signal Service U.S. Army," and number 3070 is marked "H. J. Green N.Y." Transferred from the Weather Bureau in 1904. (Smithsonian photo 61833-E.)

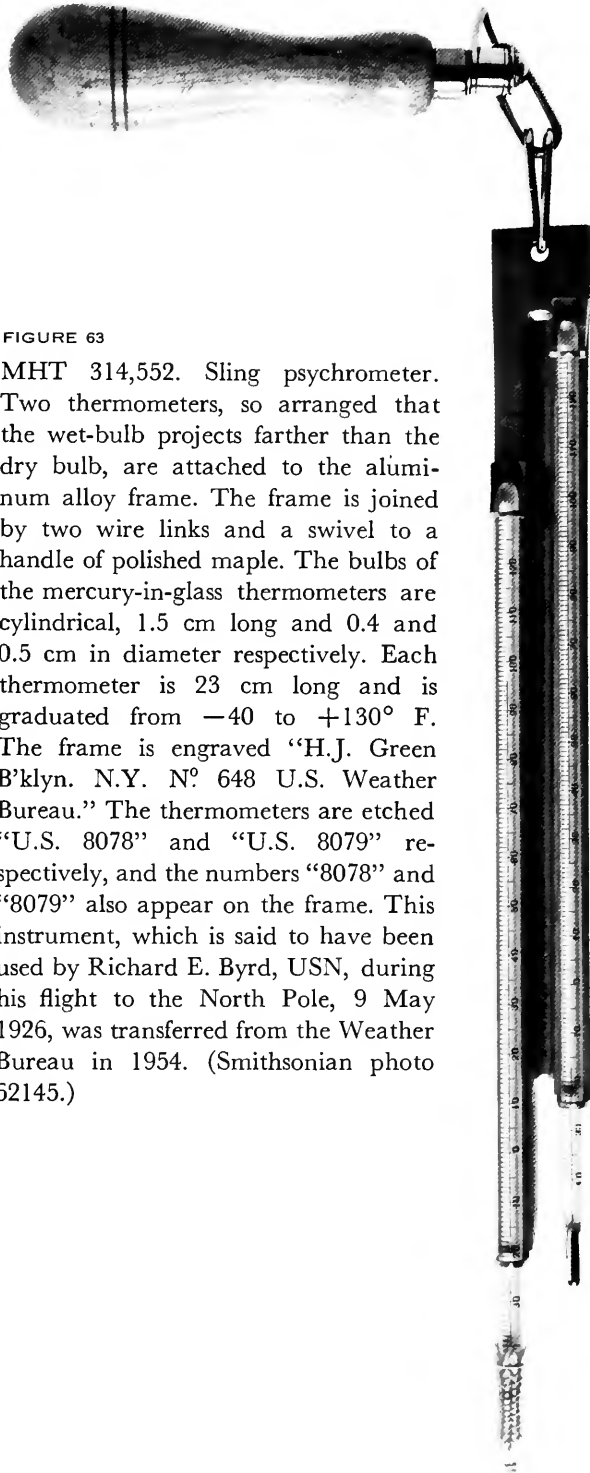

FIGURE 63

MHT 314,552. Sling psychrometer. Two thermometers, so arranged that the wet-bulb projects farther than the dry bulb, are attached to the aluminum alloy frame. The frame is joined by two wire links and a swivel to a handle of polished maple. The bulbs of the mercury-in-glass thermometers are cylindrical, 1.5 cm long and 0.4 and 0.5 cm in diameter respectively. Each thermometer is 23 cm long and is graduated from -40 to $+130^{\circ}$ F. The frame is engraved "H.J. Green B'klyn. N.Y. N^o 648 U.S. Weather Bureau." The thermometers are etched "U.S. 8078" and "U.S. 8079" respectively, and the numbers "8078" and "8079" also appear on the frame. This instrument, which is said to have been used by Richard E. Byrd, USN, during his flight to the North Pole, 9 May 1926, was transferred from the Weather Bureau in 1954. (Smithsonian photo 62145.)

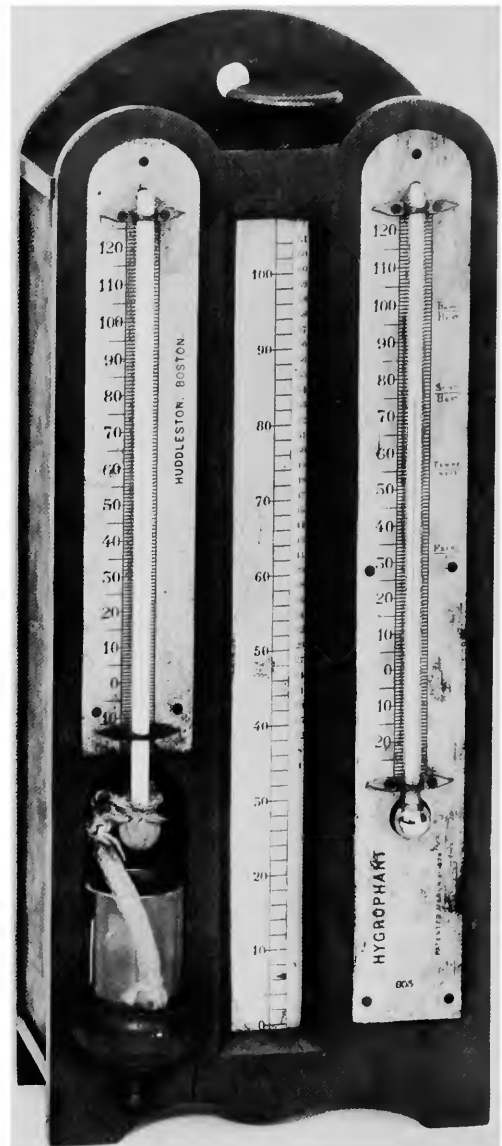

FIGURE 64

MHT 317,725. Well-made psychrometer of Russian origin, bearing the numbers A735203 and N124936, and very similar to the original Assmann psychrometer except that it has an electric motor, 110 volts A.C. or D.C., to operate the centrifugal suction fan. The thermometers are very delicate enclosed-scale thermometers (see page 41) graduated in fifths of a degree. Total length, 43 cm; diameter of fan casing, 8.9 cm. It is in a wooden box, containing a certificate dated 1942. Transferred from the Weather Bureau in 1960. (Smithsonian photo 61829-C.)

FIGURE 65

MHT 314,864. Two thermometers forming a psychrometer, with a computing device, were patented by J. Winlock and J.S.F. Huddleston (U.S. Patent 149,176, 31 March 1874). A wooden case 32 x 13 x 16 cm forms a support for the thermometers and contains the computer. This has a brass scale marked in units of two from 4 to 100, representing dry-bulb temperature, next to a narrow window 0.7 cm wide through which, by turning a knob at the top of the instrument, any one of 22 scales headed 1 to 22 (degrees of the depression of the wet bulb) can be made to appear. The relative humidity is read from the appropriate scale opposite the dry-bulb temperature. The wet-bulb thermometer is marked "Huddleston. Boston"; the dry-bulb thermometer "Hygrophant Patented March 31, 1874 805." A water container is missing. Transferred from the Smithsonian Astrophysical Observatory in 1956. (Smithsonian photo 61830-A.)



first provided by James Ivory in 1822,¹²¹ and refined three years later by Ernst August¹²² who gave to the combination of a dry-bulb and a wet-bulb thermometer the rather unfortunate name psychrometer or “cold-meter” which it has borne ever since. August is generally but unfairly considered the inventor of the instrument.

The psychrometer, then, consists of two thermometers, one of which is covered with a film of water, held by some thin wettable material such as cambric. The variations on this simple theme mainly involve means of assuring a suitable and constant motion of air past the bulbs of the thermometers. The simplest type of psychrometer, used at countless meteorological stations, is represented in the Museum by specimen MHT 230,007, figure 62. This has no provision for artificial ventilation. One way of ensuring this is to whirl both thermometers around for some time, then stop them and read them at once. An apparatus for this purpose, such as MHT 314,552, is known as a sling psychrometer (figure 63).

A much better though more complicated way of ventilating a psychrometer was devised about 1890 by Richard Assmann.¹²³ In his “aspiration

psychrometer” a clockwork fan draws air past the bulbs of the thermometers, which are enclosed in double-walled ducts of polished metal in order to minimize the effect of radiation. The Museum has a Russian instrument of this sort, but with an electric, rather than a clockwork, motor (MHT 317,725, figure 64).

To derive the dew point, vapor density, or relative humidity from the readings of the two thermometers involves a calculation, or at best a double-entry table. During the 19th century a number of devices were invented and patented, incorporating a slide-rule, nomogram or other computing device into a stand or holder for the two thermometers. An example is MHT 314,864 shown in figure 65. A much more sophisticated instrument, not quite complete, is MHT 325,390, which makes use of a nomogram.

MHT 325,390. Psychrometer with nomogram, consisting of two thermometers (one missing) on a frame 17 x 25 cm, with a nomogram and directions for its use on a piece of card attached between the thermometers. A knob and lever system permits two pointers to be set on auxiliary scales to the dry-bulb and wet-bulb temperatures. When this has been done, a third pointer indicates on the nomogram the relative humidity, the dew point, the vapor pressure, and the weight of vapor in grains per cubic foot of air. This instrument was patented on 9 April 1878, by N. M. Lowe of Boston, Massachusetts (U.S. Patent 202,276). Presented in 1964 by the Drexel Institute of Technology, Philadelphia, Pennsylvania.

¹²¹ Ivory, *Phil. Mag.*, vol. 60 (1822), pp. 81–88.

¹²² August, *Annalen der Physik*, vol. 5 (1825), pp. 69–88; 335–44.

¹²³ Assmann, *Zeits. für Instrum.*, vol. 12 (1892), pp. 1–12. Also *Abh. des K. preuss meteorol. Insts.* vol. 1 (1892), pp. 115–270.

Instruments not Referred to in the Text

Hair Hygrometer

315,744. Hair hygrometer with pulley. Hair and counterweight missing. Scale 0 (on right) to 100, marked "Secheresse" and "Humidités [*sic*]." Also inscribed "Fortin & Hermann Gen^{ve}. [?] à Paris." Brass frame on cast brass base. Overall height, 35 cm. This instrument, purchased in 1829 by the U.S. Military Academy, was transferred to the Museum in 1958.

Condensation Hygrometers

315,733. A hygrometer of Daniell's type, similar to MHT 318,271 described on page 65, except that it had a black-glass bulb, now broken, as is also the internal thermometer, the ivory scale of which is graduated from 13 to 95 [°F]. The external thermometer has been lost. Overall height 16 cm, width 10 cm. Transferred from the U.S. Military Academy in 1958.

315,734. Daniell-type hygrometer, similar to MHT 318,271 except that it has Fahrenheit thermometers, the internal one having an enclosed rolled-paper scale. The bulbs are 4 cm in diameter, the overall height 25 cm, the width 18 cm. Transferred from the U.S. Military Academy in 1958.

Psychrometers

308,200. Two sling psychrometers, similar to MHT 314,552 except that the bulbs of the thermometers measure 1.5 cm x 0.3 cm. The frames are marked "H. J. Green B'klyn. N.Y. N^o 117 [and "N^o 147" respectively] Signal Corps, U.S. Army." Transferred from the Signal Corps in 1923.

309,319. Psychrometer with Winlock and Huddleston's computing device, similar to MHT 314,864 except for the wooden stand, which is a conical frustum. Overall height, 37 cm. Transferred from the U.S. Patent Office in 1926.

314,561. Psychrometer. The frame and mounts similar to 230,007, but the waterpot is missing. The dry- and wet-bulb thermometers are on metal plates 24 x 2.3 x 0.15 cm, with formed grooves, scales on the tubes, and the numbers repeated on the mounts. Dry-bulb: -35 to +139 [°F], marked "H. J. Green B'klyn. N.Y. No. 5097 U.S. Weather Bureau." Wet-bulb: -27 to +117 [°F], marked "H. J. Green B'klyn. N.Y. No. 4860 U.S. Weather Bureau." The brass mount for the dry-bulb thermometer is stamped "J. P. Friez, Balt, Md." Transferred from the Weather Bureau in 1954.

316,419. Two thermometers and a brass stand, in a fitted mahogany case, 35 x 12 x 5 cm. Each thermometer is marked "Jas. Green, 175 Grand St. New York." One thermometer is graduated from -15 to +130 [°F] in half degrees and is 26 cm long. The other, fitted to the stand, is graduated from -10 to +120° and is 20 cm long. The case contains a stoppered bottle and an eyedropper. Transferred from the U.S. Military Academy in 1959.

317,477. Two mercury-in-glass thermometers, mounted on each side of the hinged split lid of a wooden box, 27 x 5.3 x 2.5 cm. One thermometer, number 4137, has its cylindrical bulb covered with muslin; the other, number 4135, is broken. Both are on flat nickel-plated mounts, the tubes bearing the divisions and the mounts the numbers. The box contains a small brass tube closed at one end, to hold water for wetting the bulb. Transferred from the Weather Bureau in 1960.

317,726. A ventilated psychrometer. This military instrument, of German make, has lost its thermometers. It has a motor-driven fan at the bottom, drawing air past the bulbs from the side through an elbow. (This sacrifices one of the advantages of the Assmann psychrometer referred to on page 69.) It stands 46 cm high and is packed in a heavy wooden case containing a 220 V to 12 V transformer and connecting cords and plugs. Transferred from the Weather Bureau in 1960.

317,727. A small Assmann psychrometer, with a spring-driven fan. Overall length 22 cm, diameter 5.0 cm. The enclosed-scale thermometers are only 14 cm long, graduated from -28 to $+42$ [$^{\circ}\text{C}$], and bear the numbers 12207 and 12208. The instrument is marked "R. Fuess Berlin-Steglitz 1121460." It is in a fitted box 8 cm x 8 cm x 24 cm, containing the usual accessories and a spare thermometer, number 12867. Transferred from the Weather Bureau in 1960.

321,863. A psychrometer for use in coal mines, with a leather case. Two thermometers bearing the Kew Observatory test numbers 32075 and 32076 are mounted in a brass tube 6.3 cm in diameter and 23 cm long, cut out on two sides, and marked "John Davis & Son (Derby) Ltd. No. 443 Derby & London. Reg. No. 518758." Presented in 1962 by Mr. C. F. Brooks, Superior-Sterling Company, Bluefield, West Virginia.



FIGURE 66

MHT 230,008. Standard Weather Bureau “8-inch” rain gauge, made of galvanized iron, with the rim of the funnel of brass, and sharp edged, defining a collecting area 8 inches (20.3 cm) in diameter. The vertical sides of the funnel are 5.6 cm high inside. The funnel discharges into a brass tube 6.3 cm in diameter and 51 cm long, closed at the bottom. This tube has slightly more than one-tenth the cross-sectional area of the funnel, and to measure the depth of water in the tube a thin wooden scale is used (cross section 1.4 cm x 0.2 cm), graduated in tenths of an inch and numbered in hundredths. There are two of these with the specimen, which also includes a strong iron stand, made of two castings and three rods, designed to hold the mouth of the gauge about 30 inches (76 cm) above the surface to which the stand is fastened. Transferred from the Weather Bureau in 1904. (Smithsonian photo 61832.)



FIGURE 67

MHT 315,898. Reproduction of the rain gauge recommended by the Smithsonian Institution to its observers in the mid-19th century. It has a copper funnel 13.2 cm surmounting a glass jar. Overall height, 36 cm. See *Tenth Annual Report of the Board of Regents of the Smithsonian Institution for 1855* (Washington, 1856), p. 229. (Smithsonian photo 61903-D.)

Chapter 5

Instruments for the Measurement Of Precipitation and Evaporation

The early history of the rain gauge was dealt with by Gustav Hellmann,¹²⁴ who came to the conclusion that it was invented independently in India (4th or 5th century B.C.), Palestine (A.D. 1st or 2nd century) and Korea (A.D. 15th century). In any event the rain gauge is the oldest meteorological instrument giving quantitative results. In the West it was not until 1639 that an isolated experiment on the measurement of rain was recorded in Italy.

From the beginning, a rain gauge has been simply a vessel with an open top, exposed to the sky. After a rain, the depth of water in the vessel was measured. In the 17th century, it was found that the reading of the gauge could be made easier and more accurate by leading the rain-water from a relatively large surface into a vessel of much smaller area, and measuring the depth in that. This involved the determination of the dimensions of the apparatus. All the hundreds of rain gauges designed in the last three hundred years—apart from recording gauges—have been

variations in the same simple apparatus. Such instruments are represented in the collections by two specimens, MHT 230,008 (figure 66) and MHT 315,898 (figure 67).

The first attempt at a recording gauge seems to have been made by Sir Christopher Wren, who on 22 January 1661-62, described to the Royal Society¹²⁵ a vessel which emptied itself when a certain amount of water had flowed into it—a “tipping bucket.”¹²⁶ Rain gauges using this principle are common in North America, but today a double-tipping bucket is preferred, which overbalances itself in such a way that the stream of water from the collecting funnel begins to flow into the other half of the bucket. When this is full, the bucket tips again. Each reversal of the bucket operates a counter or recorder, either mechanically, as in MHT 314,529, or electrically.

MHT 314,529. Mechanical parts, incomplete, of a tipping-bucket rain gauge designed for public display in a “Kiosk” (see page 47). It

¹²⁴ Hellmann, *Beiträge zur Erfindungsgeschichte meteorologischer Instrumente* (Berlin, 1920), pp. 39-48.

¹²⁵ Royal Society, *Journal Book*.

¹²⁶ The principle of the tipping bucket itself is, however, much older.

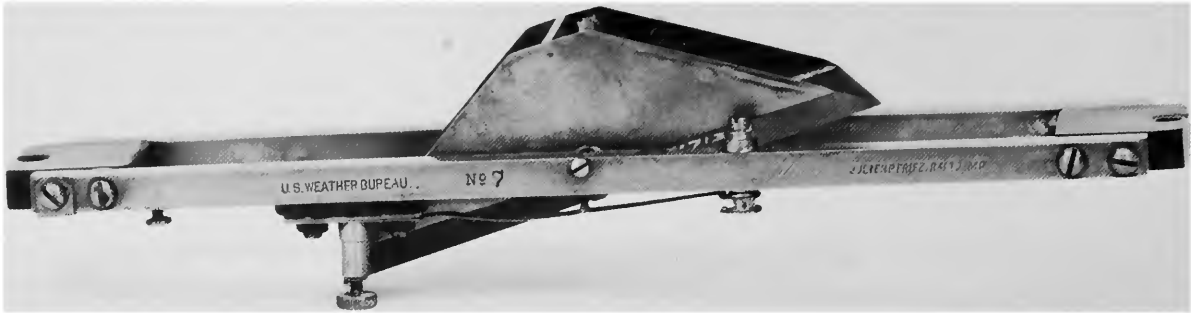

FIGURE 68

MHT 314,713. Mechanism of a tipping-bucket rain gauge. The frame is made of two square brass bars 28 cm long screwed to fiber endpieces. Contacts are made between leaf springs each time the bucket tips. Overall length, 30 cm. Transferred from the Weather Bureau in 1955. (Smithsonian photo 61902.)

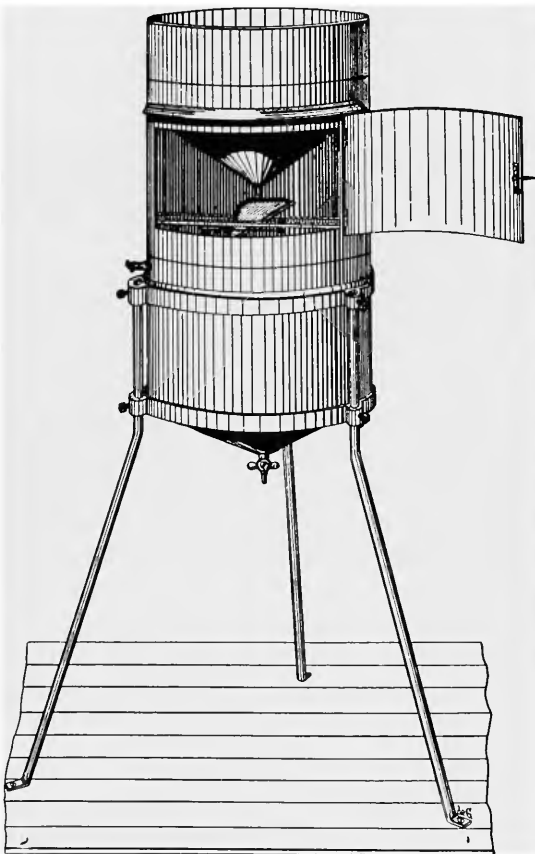

FIGURE 69

Tipping bucket mounted in the 12-inch rain gauge. (Figure 5 on page 9 of U.S. Weather Bureau Circular E, Instrument Division, 4th ed., 1922; Smithsonian photo 63884.)

consists of a double tipping bucket and a rocking shaft that, through a ratchet, operates a counter with two pointers, indicating amounts of rainfall from 0 to 12 inches in 0.01-inch steps. White-enameled dial marked "Julien Friez Belfort Baltimore, MD. U.S.A. Inches Rainfall." After operating the buckets, the water falls into a copper tank 20 x 6 x 14 cm and runs out through a spout. Transferred from the Weather Bureau in 1954.

In the latter case, each tip of the bucket momentarily closes a switch, as in the mechanism represented by MHT 314,713 (figure 68), which fits into a gauge with a collecting funnel 12 inches in diameter, as shown in figure 69.¹²⁷ The electrical impulses are recorded by a chronograph, usually the "triple register,"¹²⁸ placed indoors.

Another way of recording rain, and also snow, is to weigh the precipitation caught by a pipe of known area. Marvin's "weighing rain and snow gauge"¹²⁹ is essentially an unequal-arm balance with the vessel for the precipitation on

¹²⁷ U.S. Weather Bureau, *Measurement of precipitation*. Circular E, Instrument Division, 4th ed. (Washington, 1922), p. 9.

¹²⁸ See p. 123.

¹²⁹ U.S. Weather Bureau, *Instructions for using Marvin's weighing rain and snow gauge* (Washington, 1893).

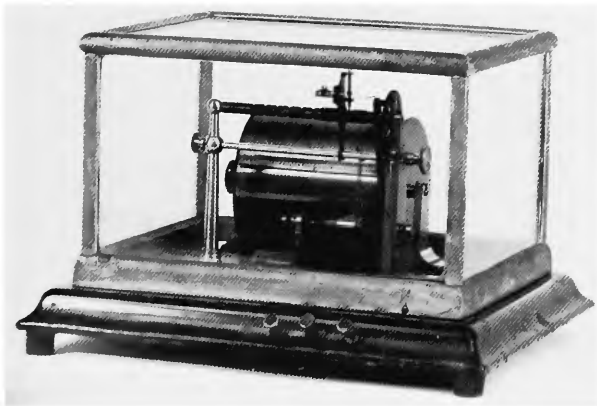

FIGURE 70

MHT 314,538. Electromagnetic device for recording the indications of a Marvin weighing rain gauge. A brass drum 9.7 cm in diameter and 11 cm long is rotated by an internal clock. A pen arm is carried on a sleeve that slides along a rod in which are cut both right-hand and left-hand square threads. The sleeve, which is prevented from rotating, carries a specially designed pin which rides in the thread and reverses the motion of the sleeve at each end of its travel. The threaded rod is rotated through a small angle by a ratchet and pawl every time a pulse of current from the rain gauge passes through an electromagnet. The cast-iron base, 32 x 28 cm, carries a brass plate marked "U.S. Weather Bureau Rain Gauge register No. 10 Made by Julien P. Friez Baltimore, Md." There is a glazed cover 27 x 22 x 18 cm. Transferred from the Weather Bureau in 1954. (Smithsonian photo 61905-A.)

the shorter arm, and a weight moved along the longer arm by an electrically operated ratchet and pawl whenever the balance needs to be restored. At the same time, a pen is moved a corresponding amount in the recording mechanism, MHT 314,538 (figure 70).

A rain gauge may make its record on the site, with no need for electricity. The weighing precipitation gauge of S. P. Fergusson, first designed when he was at Blue Hill Observatory,¹³⁰ is of this type. The specimen in the Museum, MHT

¹³⁰ Fergusson, *American Meteorological Journal*, vol. 5 (1888-89), p. 321.

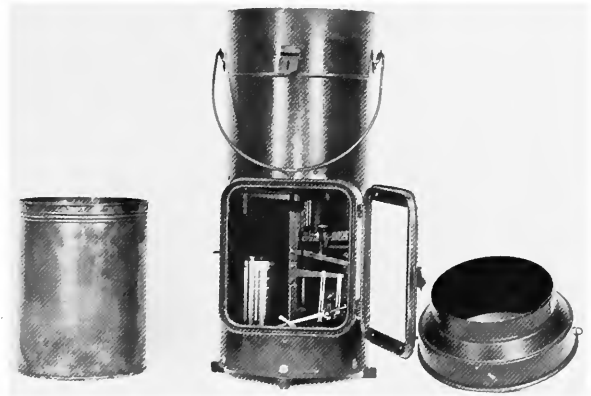

FIGURE 71

MHT 308,203. Fergusson recording precipitation gauge, final form. Rain or snow falling through an aperture 8 inches in diameter is collected in a cylindrical bucket supported on a specially designed spring balance. The pen linkage is extremely ingenious; by the design of the links and the relative weights of the various parts, the pen is caused to cross the chart three times while the receiver is moving downwards to its full extent. A dashpot containing glycerine prevents oscillations due to wind. A detachable funnel, removed when snow is expected, further reduces the effect, and also tends to prevent evaporation. The clock drives the drum one revolution per day. Overall height, 64 cm. Transferred from the Signal Corps in 1923. (Smithsonian photo 61907-C.)

308,203 (figure 71), is of an improved type.¹³¹

By mounting the tipping bucket on a balance, it is possible to make a rain gauge that gives a continuous record on a very open scale. In the century before 1960 a large number of such designs appeared, of which the Museum has a very elegant one, MHT 316,814, made by Richard Frères of Paris.¹³² It is shown in figure 72.

¹³¹ Fergusson, *Monthly Weather Review*, vol. 49 (1921), pp. 379-84.

¹³² Richard Frères, *Notice sur les instruments enregistreurs . . .* (Paris, 1889), pp. 24-26.

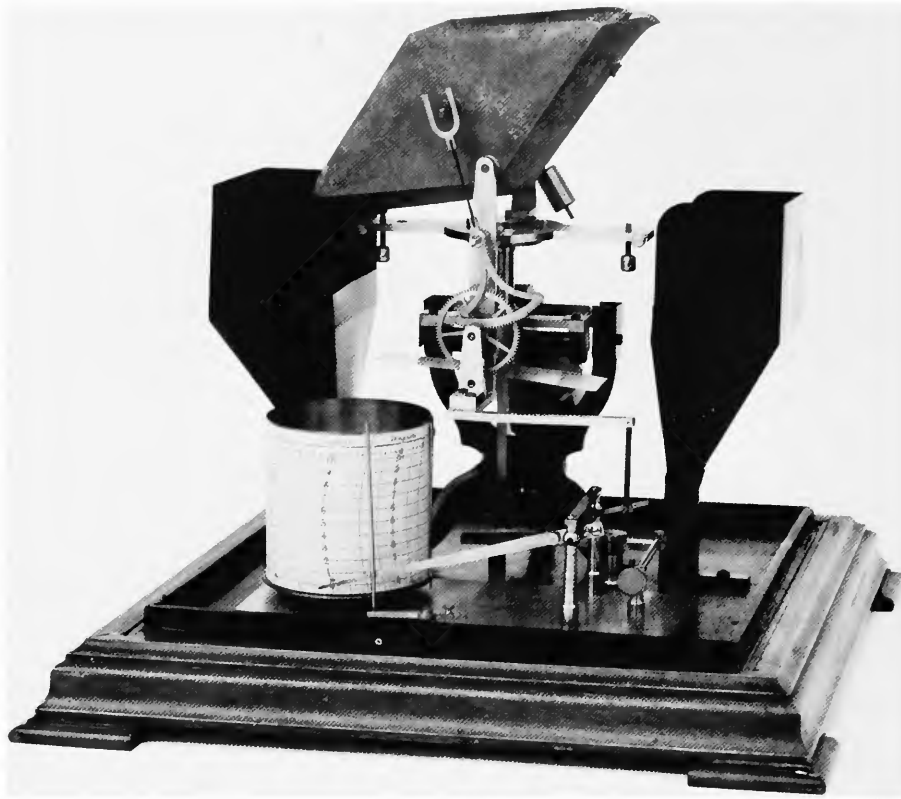

FIGURE 72

MHT 316,814. Recording rain-gauge mechanism built by Jules Richard of Paris about 1890. The tipping buckets, 20 cm long and 9 cm wide, are mounted on a Roman balance which gradually descends under the increasing weight of water collected by one of the buckets, and through a system of levers causes a pen to rise in proportion to the added weight of water. When 10 mm of rain have accumulated, the buckets tip, and the pen returns to zero. The tipping is slowed

down by a fan governor geared up from a shaft moved by the buckets. The instrument is on a mahogany base 43 x 45 cm, and has a glazed metal cover 37 x 36 x 36 cm with a hole in the top for the pipe coming from the collecting funnel. The baseplate is marked "Richard Frères Constructeurs Brevetés Paris 10298 Made in France." This was at Mount Weather, Virginia, and was transferred from the Weather Bureau in 1959. (Smithsonian photo 61909-B.)

A large number of recording rain gauges using floats, some with collecting chambers emptied by siphons, have been designed and are used to some extent in many countries. They are easily damaged by frost, however, and scarcely used at all in North America. The type is not represented in the Museum.

Apart from measuring the amount of rainfall, there is—or was—some interest in recording the

beginning and ending of light rain. A way of doing this was first devised about 1860 in France,¹³³ and an instrument in the Museum (MHT 316,817) is a much later form designed by S. P. Fergusson and used in the 1920s at a

¹³³ Hervé-Mangon, *Annuaire Soc. Météorol. de France*, vol. 8 (1860), pp. 183–84.

few stations of the Weather Bureau.¹³⁴ The idea is to expose a moving record sheet, crosshatched in a somewhat soluble ink, to the sky through a small hole, so that the crosshatching will be blurred where it becomes wet. There are also time lines on the moving paper. This instrument has received the name of "ombroscope."

MHT 316,817. "Ombroscope." A drum 20 cm in diameter and 15 cm long is driven by internal clockwork and turns on a shaft having a fast screw thread working in a fixed nut, so as to advance the drum axially as it turns. A hole in a rounded cover is close to the top of the drum. The device is on a cast-iron base 52 cm long and 28 cm wide. There is no indication of its origin. Transferred from the Weather Bureau in 1959.

The supply of water for precipitation is replenished by evaporation from land and sea, and at least since the time of Claude Perrault (1613–1688) attempts have been made to measure the amount of water evaporated.¹³⁵ The early experimenters simply measured or weighed the water in a vessel before and after it had been exposed to the air, but it was soon realized that vessels of different sizes and shapes would give widely different results. It was also realized that much evaporation takes place from the leaves of plants and from the soil, so that there is some point to exposing damp surfaces of porous earthenware,¹³⁶ paper,¹³⁷ or even earth.¹³⁸ The one instrument of this sort in the Museum is a recording evaporation gauge, or atmograph, from Japan, MHT 316,273, shown in figure 73.

¹³⁴ Roy N. Covert, *Journal of the Optical Society of America & Review of Scientific Instruments*, vol. 10 (1925), pp. 345–46.

¹³⁵ Perrault, *Hist. Acad. Sci. 1666–86* (Paris, 1733), vol. 1, pp. 115–16; Edmond Halley, *Phil. Trans.*, vol. 18 (1694), pp. 183–90.

¹³⁶ John Leslie, *A short account of experiments and instruments depending on the relations of air to heat and moisture* (Edinburgh, 1813), p. 81.

¹³⁷ Albert Piche, *Bull. Assoc. Sci. de France*, vol. 10 (1872), pp. 166–67.

¹³⁸ A. Bellani, cited by Muncke in *Gehler's Physikalische Wörterbuch* (Leipzig, 1825–45), vol. 1, p. 436.

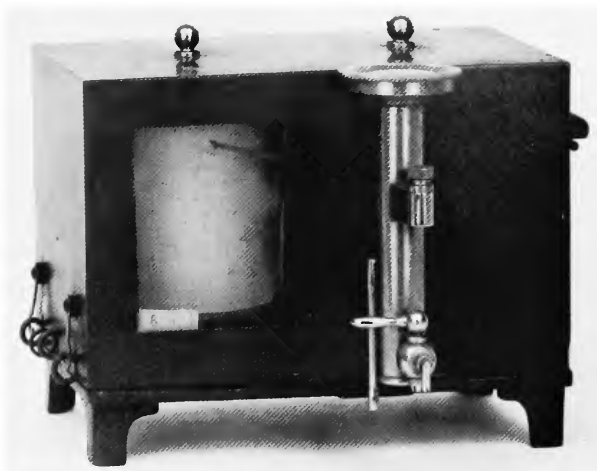

FIGURE 73

MHT 316,273. Japanese atmograph, recording the evaporation from an area of absorbent paper (3.5 cm in diameter) in contact with a mass of cotton wick dipping into water in a vertical tube (2.2 cm in diameter). This tube is connected by a side tube to a cylinder 5.3 cm in diameter containing a float linked to a pen arm. The vertical tube has a filling plug and a drain cock. The cast-iron base and sheet-metal cover are of the design and dimensions common in the United States (see figure 58, MHT 327,634). The clock and drum are also very similar. This instrument, which dates from 1944, is marked "H. Ota No. 529." Transferred from the Weather Bureau in 1959. (Smithsonian photo 61906-A.)

Instrument not Referred to In the Text

MHT 316,818. Part of an experimental recording rain gauge, incomplete, but probably had tipping buckets. It is in a copper box 23 x 18 x 25 cm, on four legs 13 cm high, and with a copper lid. Transferred from the Weather Bureau in 1959.



FIGURE 74

MHT 247,698. Circular plate of wood, 32 cm in diameter and 2.2 cm thick, with 32 hopper-shaped depressions near the edge, each with a hole at the bottom. A written label is fixed to the upper surface of the plate, and reads as follows: "The Base of a self-registering Wind Vane erected by James H. Coffin in 1837 at Ogdensburg, N.Y. A hopper attached to the foot of the vane rod received a continuous stream of dry sand. A spout six inches long carried from this hopper, one ounce of sand every fifteen minutes, and dropped it into the appropriate

receptacle. At the end of the month the sand contained in these thirty-two receptacles, was weighed. The number of ounces thus showed the duration of the wind for each of the points of the compass. A plate in the Appendix of Coffin's 'The Winds of the Globe' [published in the *Smithsonian Contributions to Knowledge*, volume 20; Washington, 1876] gives the results obtained by this, and other apparatus made by him at Ogdensburg." Presented in 1907 by Professor Selden J. Coffin. (Smithsonian photo 61904-B.)

Chapter 6

Instruments for Measuring The Surface Wind

Wind Vanes and Wind-direction Recorders

The wind vane is the best known of all meteorological instruments, and also one of the oldest, for there seems to have been a wind vane on the “Tower of the Winds” built at Athens by Andronicus of Cyrrha about 50 B.C.¹³⁹ A few years afterwards, Marcus Terentius Varro (ca. 114–26 B.C.) had a wind vane on his farm, the position of which was indicated by a pointer inside his house.¹⁴⁰ Sixteen hundred years later Egnatio Danti, the bishop of Velletri, used gearing to make a wind vane show the direction of the wind by means of a vertical dial and pointer mounted on a wall.¹⁴¹ Meanwhile, innumerable “weathercocks” had been mounted

¹³⁹ Vitruvius, *On Architecture*, trans. Frank Granger (Loeb Classical Library, Cambridge, Massachusetts, and London, 1955), p. 57 (book 1, chapter 6, paragraph 4).

¹⁴⁰ Varro, *De re rustica*, book 3, chapter 5, paragraph 17. See the translation by T. Owen (Oxford, 1800), p. 214.

¹⁴¹ Danti, “La fabbrica dello anemoscopio, strumento verticale” in his *Primo volume dell’uso et fabbrica dell’astrolabio, et del planisferio* . . . (Florence, 1578), pp. 273–281.

on the steeples of churches and the towers of public buildings. The first mechanical improvement of any importance was described by Johann Georg Leutmann in 1725.¹⁴² He provided a conical pivot bearing to carry the weight of the vane.

For centuries, wind vanes had been flat plates, until in 1797 G. F. Parrot described the so-called “splayed” vane, which had two plates making an acute dihedral angle, and giving a greater turning moment for small changes in the direction of the wind.¹⁴³ In the 20th century many forms of wind vane have been introduced,¹⁴⁴ the best of them making use of airfoil sections.

The Museum of History and Technology has comparatively few scientific wind vanes, though some of the anemometers to be described in the next section have vanes incorporated in their construction in order to make them face the wind.

¹⁴² Leutmann, *Instrumenta meteorognosiae inservientia* (Wittenberg, 1725), p. 116.

¹⁴³ Parrot, *Magaz. für den neuesten Zustand der Naturk.*, vol. 1 (1797), pp. 154–58.

¹⁴⁴ See E. Kleinschmidt, ed., *Handbuch der meteorologischen Instrumente* (Berlin, 1935), pp. 338–40.

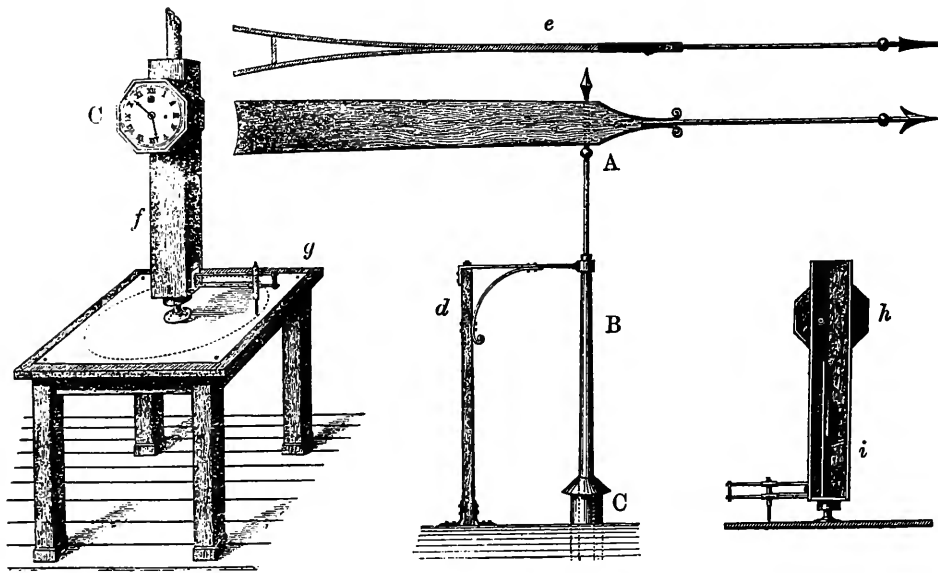

FIGURE 75

Diagram of the Smithsonian Institution's wind vane of 1860. MHT 322,611 is a model (60 cm long and 37 cm high) of this.

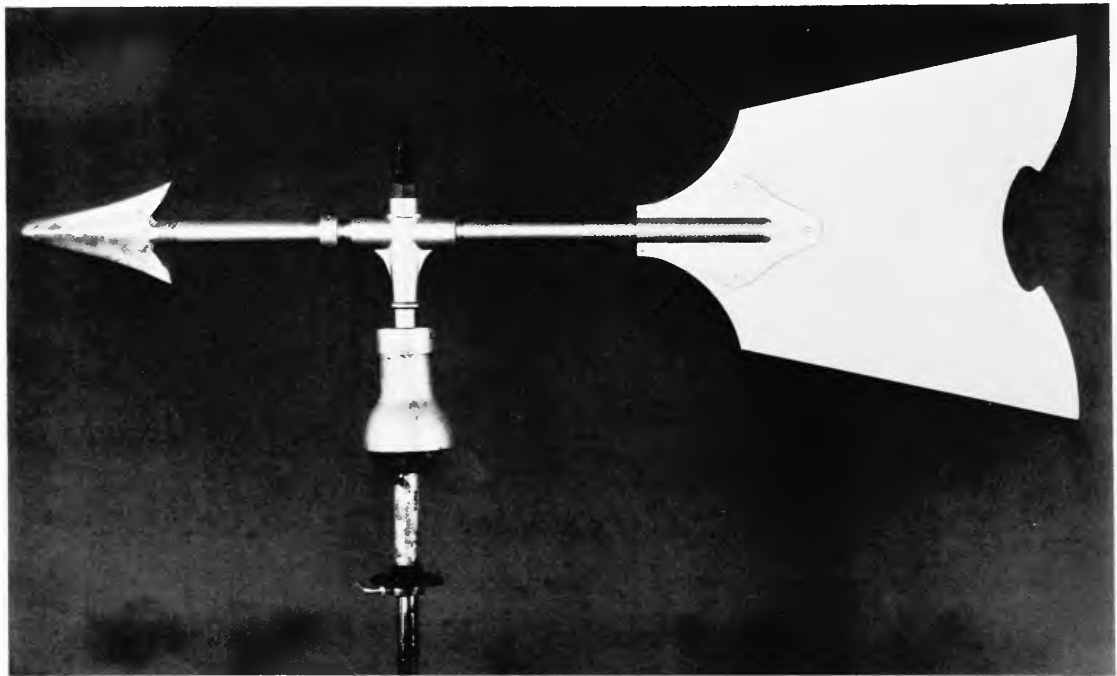

FIGURE 76

MHT 315,906. Flat vane, strongly constructed of heavy metal, with a gilt arrow. The base of the vane carries four insulated sectors, one or two of which can be touched by a contact arm rotating with the vane. Overall length 91 cm, height 65 cm. Transferred from the Weather Bureau in 1958. (Smithsonian photo 61903-B.)

The oldest and most interesting specimen is a small part of a wind-direction recorder designed in 1837 by the pioneer American meteorologist James H. Coffin (1806–1873) of Ogdensburg, New York (MHT 247,698, figure 74). The depressions carved in this plate can be nothing more than funnels, leading sand from a rotating spout to an array of boxes or jars beneath the board.

In 1860 a recording wind vane was in operation at the Smithsonian Institution in Washington,¹⁴⁶ and there is a model of the vane, MHT 322,611, in the Museum. It is on a scale of about one tenth. The original was enormous, the “feather part” being “composed of two pieces of pine board about one foot wide, eleven feet long, and half an inch thick.” As shown in figure 75, the shaft rotated a box containing a clock-driven mechanism that drew a pencil radially inwards while the changes in wind direction were moving it in circular arcs.

The remaining three specimens are more recent in design and have to do with electrical recording. By providing a vane with a contact on its shaft and giving the contact suitable dimensions, it can be made to touch one of four insulated segments of a conducting ring when the vane is pointing within 22½ degrees of one of the cardinal directions N, E, S, and W, and to touch two of them when it is within 22½ degrees of the intermediate directions NE, SE, SW, and NW. Thus, with five connecting wires and a suitable recorder, the wind direction may be recorded to eight directions. MHT 315,906 (figure 76) is such a vane. With eight segments and nine wires, 16 directions can be distinguished and recorded by an eight-pen recorder such as MHT 308,193 (figure 77).

For use in airport control towers it is valuable to have a distant indication of the wind direction that is not limited to eight or sixteen points. This can be done very easily by the use of the so-called self-synchronous motors, small electric motors

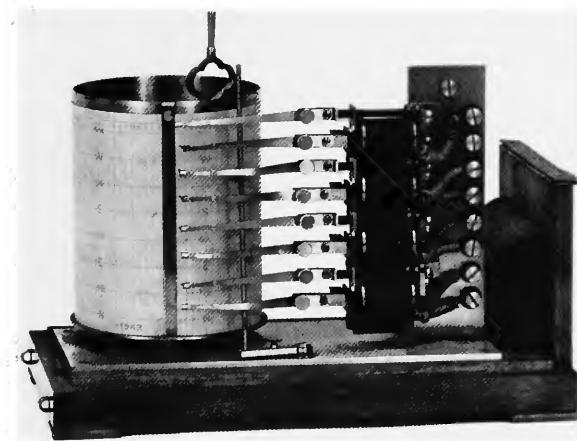

FIGURE 77

MHT 308,193. Electrical wind-direction recorder capable of recording to 16 directions by means of 8 pens operated by 8 electromagnets. Each magnet makes a jog in a line, drawn by its associated pen, when a contact arm revolved by a suitable wind vane is touching the sector that pertains to it. In a wooden case 25 x 14 x about 18 cm (the glazed top is missing), the array of electromagnets is mounted on a brass plate 21 x 8.8 cm, as is a drum 9.2 cm in diameter x 11.4 cm high. The drum contains an integral clock of the usual Richard type, which revolves it in seven days. On the brass plate is the Richard Frères trademark and the number 82862. Transferred from the Signal Corps in 1923. (Smithsonian photo 61906.)

with rotors fed with single-phase alternating current, and three-phase stators connected together. When either of two such motors is rotated by external means, the shaft of the other will rotate to exactly the same extent, provided it is not overloaded. The Museum has the indicating part of a Japanese installation of this kind (MHT 316,269).

MHT 316,269. A self-synchronous indicator in a heavy cast-iron case, 19 cm in diameter and 10 cm deep, marked “Nishin Electrical Inst. Works. Model 98.” It has a translucent illuminated dial with a rheostat for adjusting the brightness. Transferred from the Weather Bureau in 1959.

¹⁴⁶ *Annual Report of the Board of Regents of the Smithsonian Institution for 1860* (Washington, 1861), pp. 414–16.



FIGURE 78

MHT 318,489. Reproduction of Hooke's swinging-plate anemometer. It is of brass and copper except for the plate, which is of wood. The scale is marked "10, 20, . . . 80." Overall height 50 cm, base 15 cm in diameter, quadrant 17 cm in radius. Made by L. C. Eichner in 1961. (Smithsonian photo 61902-B.)

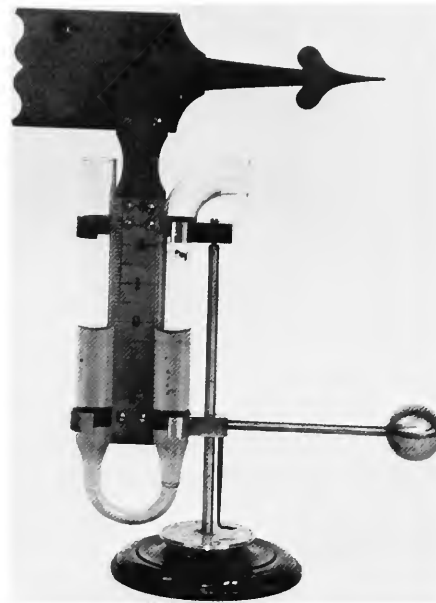

FIGURE 79

MHT 325,389. Demonstration model of a pressure-tube anemometer and wind vane, after Lind. The glass tube is 2.4 cm in diameter and 24 cm high, the brass vane 25 cm long. There is an iron base 12.5 cm in diameter, carrying a wind rose in red on a silvered brass plate. Marked "11D11." Presented in 1964 by the Drexel Institute of Technology, Philadelphia, Pennsylvania. (Smithsonian photo 61830-B.)

Anemometers and Anemographs

Instruments for measuring the speed of the wind fall naturally into four main classes, all represented in the collection. These classes are:

- Pressure-plate anemometers.
- Pressure-tube anemometers.
- Rotation anemometers.
- Anemometers depending on cooling.

Of these the oldest is the pressure-plate anemometer, the idea of which might naturally occur to anyone who had seen a shopkeeper's sign swinging in the wind, but Leon Battista Alberti (1404–

1472) seems to have been the first to record the suggestion,¹⁴⁶ in a sketch of a rectangular swinging plate supported at one edge, and a quadrant to indicate its inclination to the vertical. The same idea occurred—almost certainly independently—to Robert Hooke,¹⁴⁷ and his swinging-plate anemometer is represented in the Museum by a reproduction, MHT 318,489, figure 78.

The wind blowing into the open end of a tube increases the pressure within it, while if it blows

¹⁴⁶ Alberti, *Opuscoli morali* (Venice, 1568), p. 253. This was written about 1452.

¹⁴⁷ Anon., *Phil. Trans.*, vol. 2 (1667), p. 444.

across the end it reduces the pressure. The first anemometer depending on this principle was suggested in or before 1722 by Pierre Daniel Huet.¹⁴⁸ It was reinvented by James Lind half a century later,¹⁴⁹ and the Museum has a model (MHT 325,389, figure 79) constructed approximately according to his illustration, but provided with a wind vane to face the tube into the wind. Since the excess and deficit of pressure vary as the square of the wind speed, the scale of such an instrument is far from linear.

In more recent times, the perfection of the tube anemometer has been associated with the name of William Henry Dines (1855–1927), who first became attracted to anemometry when investigating the force of the wind on engineering structures. In order to make it unnecessary to point the suction tube exactly at right angles to the wind stream, he used the device of drilling a large number of radial holes in a smooth tube, as in the portable anemometer (MHT 314,951) shown in figure 80.¹⁵⁰

With the cooperation of the London instrument maker R. W. Munro, Dines also designed a recording anemometer in which the pressure in a tube facing the wind acts on the underside of a float and the suction in a vertical tube with four rows of holes is applied above it. The Museum has one of these instruments, MHT 316,813, and it is more informative to reproduce a cross section of such an instrument¹⁵¹ in figure 81 than a photograph of the outside of the specimen in the Museum. The reader's attention is directed to the trumpet-shaped inner surface of the float, which makes the deflection of the pen linear in wind speed. The correct theory of this float was first given by E. Gold.¹⁵²

¹⁴⁸ *Huetiana; ou pensées diverses de M. Huet, Evêque d'Avanches* (Paris, 1722), pp. 55–58.

¹⁴⁹ Lind, *Phil. Trans.*, vol. 65 (1775), pp. 353–65.

¹⁵⁰ A patent application seems to have been made and abandoned.

¹⁵¹ Dines, *Collected Scientific Papers* (London, 1931), p. (11).

¹⁵² *Quarterly Journal Royal Meteorological Society*, vol. 62 (1936), pp. 170–77.



FIGURE 80

MHT 314,951. Portable anemometer of W. H. Dines. It operates on the suction produced when the wind blows past a tube with a number of small drilled holes. A glass tube 26 cm long is cemented into a small cistern at the bottom and into a brass tube 2.6 cm in diameter and 4.7 cm long that has 12 co-planar holes drilled in it, each about 1.2 mm in diameter. There is also a brass screw ending in a pad, which can be used to seal the end of the glass tube for transport. On each side of the glass tube is a scale, engraved on brass, on the left 0 to 30 lbs per square foot, and on the right a square-law scale up to 100 miles per hour. The cistern, the upper tube, and the scale are machined out of a single brass bar 30.6 cm long. A bayonet fitting allows the anemometer to be supported in a brass tube 31.4 cm long and 3.1 cm in diameter, which forms a handle when the inner part is pulled out, and a container when it is pushed in. There is a brass-wire bail for hanging the instrument up. Overall length: closed, 35 cm; open 60 cm. Engraved on the inner part, "Dines Patent Portable Anemometer 84" and on the outer tube, "L. Cassella. London." Deposited by the Smithsonian Astrophysical Observatory in 1956. (Smithsonian photo 61829-B.)

We now come to the rotation anemometers, which are of two main classes: windmill (or propeller) anemometers and cup anemometers. It was natural that the windmill, an old device, should be used to measure the speed or force of the wind, and this was first done in the 18th century,¹⁵³ though Christian von Wolff's windmill was prevented from rotating continuously, the deflection from a zero being a measure of

¹⁵³ Christian von Wolff, *Aerometriae elementa* (Leipzig, 1709), pp. 320–23.

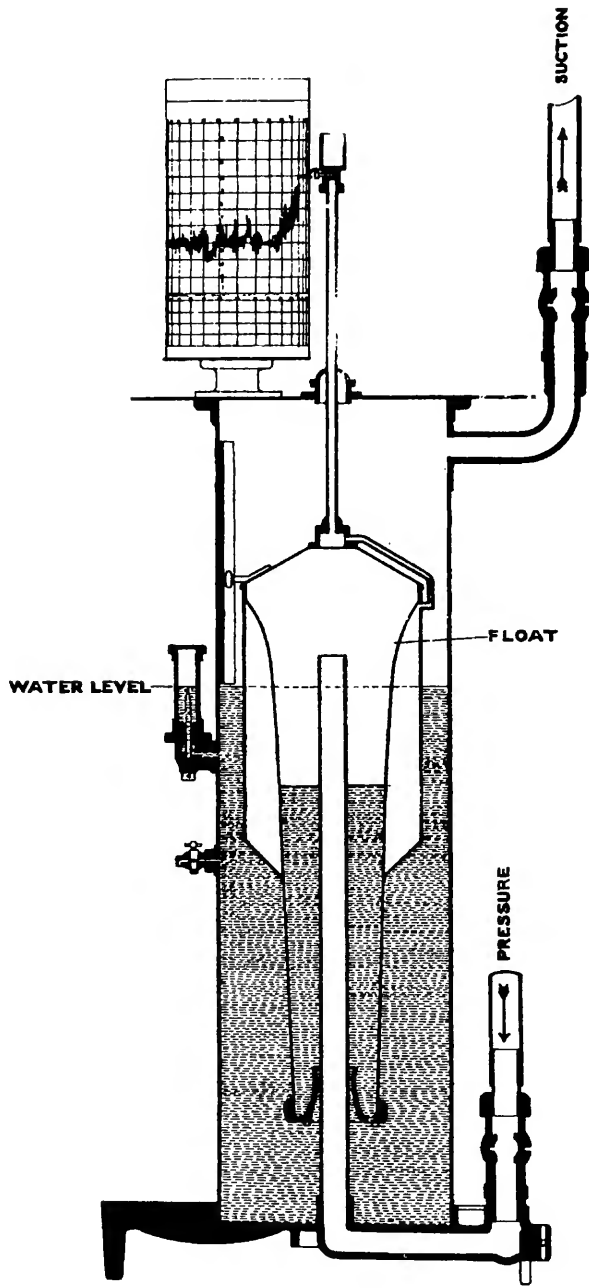

FIGURE 81

Diagram of the recording part of the Dines—Munro pressure-tube anemometer. MHT 316,-813 consists of the head as well as the recording part. The head is a flat vane measuring 15 x 26 cm, arranged to direct a tube 2.5 cm diameter and 20 cm long into the wind. This tube communicates with the bottom of the recorder through a long pipe. The vane is supported by a rod and a long sleeve bearing, nearly airtight, above a larger tube 5.4 cm in diameter and 22 cm long, which is perforated with four rows of holes, 20 in each row. This tube communicates with the top of the recorder. The recorder is in the form of a tank 26 cm in diameter and 74 cm high, on a base with 3 leveling screws, and provided with a water-level gauge. It has a cast-brass plate marked "Dines's Pressure Tube Anemometer. R. W. Munro Maker London." The top of the tank is closed by a plate 37 cm in diameter, through which the fitting for the pen arm (missing) protrudes, and which carries a recording drum 12.7 cm in diameter and 22 cm long, with an internal clock. This drum is marked "Negretti & Zambra, London" and is probably not original. Overall, the instrument stands 106 cm high. Transferred from the Weather Bureau in 1959. (Diagram from figure 1, page 11, in *Collected Scientific Papers of William Henry Dines.*)

FIGURE 82

MHT 316,275. Japanese windmill-type anemometer and wind vane for transmitting indications electrically to a distance. On a pipe mast 60 cm long is supported a splayed wind vane 35 cm long and 18 cm wide, built on to a rectangular metal box 18 x 7 x 4.5 cm containing a cam-operated contact system geared to a 6-bladed mill 29 cm in diameter, with flat elliptical blades. The rotation of the vane moves three insulated contacts around three composition resistors, forming the transmitting portion of an electromagnetic wind-direction indicator. These parts and their corresponding terminals are protected by a galvanized iron tube 7 cm in diameter and 25 cm long. Transferred from the Weather Bureau in 1959. (Smithsonian photo 61833.)

the wind force. For meteorological use, a windmill or propeller is necessarily combined with a wind vane so that the former faces into the wind at all times. The Museum has one example, MHT 316,275, figure 82. A more common form of this general type is intended to be held in the hand, for measuring the movement of air in ducts, mine workings, and tunnels. For this purpose a light mill is usually mounted in a short tube that almost fits it, as in MHT 308,183, figure 83, which has the unusual addition of a stopwatch interconnected with the counter that registers the revolutions of the windmill.



For meteorological observations the cup anemometer, invented by T. R. Robinson in 1846¹⁵⁴ after he had thought about some experiments by R. L. Edgeworth,¹⁵⁵ has the advantage that no wind vane is needed to direct it. Furthermore, it can be made very strong. For many years the standard anemometer of the U.S. Weather Bureau was the type represented by

¹⁵⁴ B.A.A.S., *Southampton, 1846*, Sections, pp. 111-12.

¹⁵⁵ Edgeworth, *Phil Trans.*, vol. 73 (1783), pp. 136-43.



FIGURE 83

MHT 308,183. Windmill anemometer having 8 vanes in a tube 9.3 cm in diameter and 5.3 cm long, mounted on a rectangular tube carrying a stopwatch and a measuring dial in "metres," engraved "Jules Richard Constructeur Paris." The stopwatch and the gearing are so interconnected that when the watch is started the counter is automatically connected to the windmill. Transferred from the Signal Corps in 1923. (Smithsonian photo 61833-A.)



FIGURE 84

MHT 230,001. Cup anemometer by Julien P. Friez. It has 4 aluminum hemispherical cups each 10 cm in diameter on a radius of 17 cm to their centers. The wheel is supported by a journal bearing at the top and a pivot at the bottom of the tubular frame, which enlarges at the bottom to a cylinder containing a counter in "miles" and "tenths" and electrical contacts that close a circuit once for every mile of wind, each tenth contact being of longer duration. Overall height, 41 cm. This type was first used by the Weather Bureau in 1871. Transferred from the Weather Bureau in 1904. (Smithsonian photo 61829.)

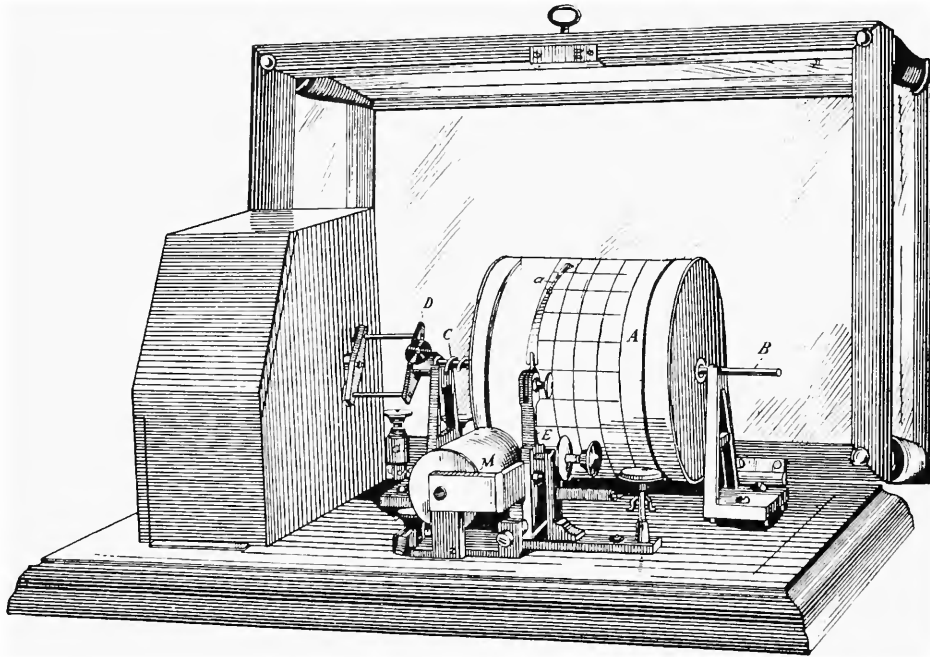

FIGURE 85

Diagram of a chronograph ("single register"). MHT 308,204 has a drum 9.7 cm in diameter and 9.2 cm long which is turned and simultaneously moved axially by means of a clock and a fast screw. A pen makes a helical line on the paper that covers the drum except when an electrical impulse from an instrument (anemom-

eter) jogs it briefly sideways. The instrument is on a heavy japanned iron base, 39 x 33 cm, and is marked "Julien P. Friez & Sons Belfort Observatory Baltimore Md." Transferred from the Signal Corps in 1923. (Diagram from U.S. Weather Bureau Circular D, 2d ed., 1900, figure 16 on page 41; Smithsonian photo 63888.)



FIGURE 86

MHT 252,975. Cup anemometer with 4 cups 7.6 cm in diameter on a radius of 15 cm to their centers, supported 15 cm above a brass box 12 x 3 x 4.5 cm high, which contains 4 geared counter wheels indicated as "1000 M," "100 M," "10 M," "1 Mile." Marked "J. W. Queen & Co. Philadelphia." Transferred from the U.S. Geological Survey in 1909. (Smithsonian photo 61829-A.)

the specimen 60,203M, in which the cups are geared to two counting wheels.

60,203 M (Division of Military History). Cup anemometer, having four hemispherical brass cups each 6.3 cm in diameter on a radius of 10 cm to their centers. The wheel is supported by a journal bearing at the top and a pivot at the bottom of the tubular frame, which enlarges at the bottom to a cylinder containing a counter in "miles" and "tenths." Overall height 21.5 cm. All is of brass construction except for iron radial arms. Marked "A. Hahl & Co., Balt., Md." This type was first used by the Weather Bureau in 1871, when it was part of the Army Signal Corps, from which this instrument was received.

This standard type of anemometer is also represented by MHT 230,001, figure 84, in which one of the wheels carries pins that operate an electrical switch, enabling distant recordings of the run of the wind,¹⁵⁶ by the use of a chronograph or "single register" (MHT 308,204), which is illustrated by the use of an engraving, figure 85.¹⁵⁷ Both these instruments were introduced in the 1870s.

Cup anemometers made without electrical recording are exemplified by the rather smaller instrument MHT 252,975, shown in figure 86.

¹⁵⁶ See U.S. Weather Bureau, *Instructions for . . . wind measuring and recording apparatus*, Circular D, Instrument Division. 2d ed., 1900, pp. 9-23.

¹⁵⁷ *Ibid.*, p. 41.



FIGURE 87

MHT 316,001. Kata-thermometer, with a cylindrical bulb 3.5 cm long and 1.8 cm in diameter, and a tube 0.6 cm in diameter, containing red spirit. The tube has only two graduations, and there is a white-glass back strip. On the front of the tube is etched "Mean 36.5° C," and on the back "N°. 2562 J. Hicks 8, 9, & 10 Hatton Garden London F472." Overall length, 22.5 cm. Deposited by the Smithsonian Astrophysical Observatory in 1958. (Smithsonian photo 61836-E.)

The relative merits of 3-cup and 4-cup wheels were the subject of acrimonious discussion, which seems to have led to a fairly general adoption of the 3-cup anemometer. The Museum has such an anemometer and its associated recorder (MHT 316,943).

MHT 316,943. Anemometer and recorder. The cup wheel consists of 3 cups 12.7 cm diameter with centers 15.8 cm from the axis. The wheel is supported 28 cm above a counter and contact mechanism (similar to MHT 230,001) marked "Henry J. Green Scientific Instruments B'klyn. N.Y. U.S.A." The recorder has a drum driven by a clock, 1 revolution in 6 hours, and traversed axially by a coarse screw. An electromagnet jogs a pen at each contact made by the cup wheel. Similar to MHT 308,204 (figure 85) except for the glazed wooden case, which measures 35 x 25 x 8 cm, and bears a brass plate engraved "Hahl & Co Balto Md." Presented in 1960 by the Lick Observatory, University of California.

One of the advantages of rotation anemometers is that it is possible to incorporate a small permanent-magnet A.C. generator, the current from which can be rectified and measured on a milliammeter. The Museum possesses the indicating portion of such a combination, MHT 316,270.

MHT 316,270. Electrical indicator for use with rotation anemometer. A cast-iron case, 18 x 20 x

13 cm, marked "Nishin Denki, Kyoto, 1942. Model 98," contains a milliammeter with a dial reading from 0 to 60, and a rheostat to control the transillumination of the dial. Transferred from the Weather Bureau in 1959.

The various anemometers, used chiefly for special research, which measure the speed of the wind by its cooling power, are represented in the Museum only by the Kata-thermometer,¹⁵⁸ devised primarily for biometeorology. This is an alcohol-in-glass thermometer with a relatively large bulb, having two marks on the scale at 35° C and 38° C, a range which brackets the normal human body temperature. To use it, the thermometer is warmed to slightly above the upper mark, and hung in the wind. The time taken for the temperature to fall from 38 to 35° C is measured with a stopwatch, and related to the wind speed by a previous calibration. Like all anemometers of this sort, it is particularly suitable for measuring very low wind speeds. One of the specimens in the Museum, MHT 316,001, is shown in figure 87.

¹⁵⁸ L. Hill, O. W. Griffith, and M. Flack, *Phil. Trans., Section B*, vol. 207 (1915), pp. 183-220.

Instruments not Referred to in the Text

308,181. Four-cup anemometer, similar to MHT 230,001 apart from unimportant details, except that the cup wheel is braced by four strips of metal between the arms. Marked "Anemometer No. 1031. Type 1—1/60 Mile Julien P. Friez and Sons Baltimore, Md., U.S.A." Transferred from the Signal Corps in 1923.

308,182. Windmill anemometer, marked "A. Stoppani & C^o S. A. Berne," consisting of eight aluminum vanes mounted in a tube 9 cm in diameter, and geared to two dials, reading 0–100 meters and 0–100 hectometers. With the dials is mounted a stopwatch. Transferred from the Signal Corps in 1923.

314,535. A cup anemometer with four hemispherical cups 10 cm in diameter, their centers at a radius of 17 cm from the vertical shaft. The rotation of the cups operates counting wheels that can total up to 1,000 miles of wind, and a contact system that makes a contact for each mile of wind, with a longer contact at every tenth mile. Overall height, 41 cm. Marked "USWB 1580–S." Transferred from the Weather Bureau in 1954.

316,268. A Japanese version of the Dines—Munro tube-anemometer head, similar to that in MHT

316,813, but marked "Suzuki Meteorological Inst. Co., Tokyo 1944 Serial 6104." Overall length 50 cm, height 50 cm. Transferred from the Weather Bureau in 1959.

317,274. A windmill anemometer having 10 vanes running inside a brass tube 15.3 cm in diameter and 4.6 cm long. A dial is geared to the mill and graduated in feet from 0–100; a small dial is marked "Hds," 0–10. Signed "Keuffel & Esser Co. New York." The mahogany case, 18 x 18 x 7 cm, has a correction table inside the lid, headed "Anemometer No. N5967–11673." Presented in 1960 by the Department of Chemistry, Yale University.

317,457. A Kata-thermometer, similar in general appearance to MHT 316,001, but 21 cm long and graduated from 35 to 40 [° C]. It is marked "J. Hicks 8 9 & 10 Hatton Garden London N^o 261 F531." It was purchased by the Weather Bureau in 1919, and transferred to the Museum in 1960.

323,501. An electromagnetic counter for use with a cup anemometer, in a wooden case 15 x 11 x 7.5 cm. It is unsigned, but there is a penciled notation "Counter, Revolution From Mt Weather Nov 7, 1934." Transferred from the Weather Bureau in 1963.

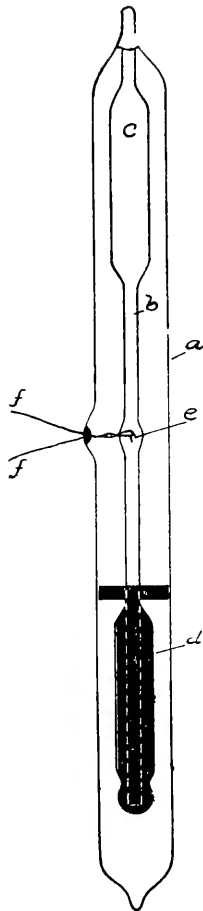

FIGURE 88

Construction of the electrical sunshine recorder. (Figure 1 on page 2 of U.S. Weather Bureau Circular G, 5th ed., 1941; Smithsonian photo 63887.)



FIGURE 89

MHT 308,176. Sunshine recorder of the differential-thermometer type, for electrical recording. A glass tube, 2.2 cm in diameter and 25 cm long, contains a differential thermometer with a black bulb and a clear bulb and a narrow tube between them, dipping into the blackened bulb, which contains mercury and alcohol. There are two platinum wires sealed into the connecting tube, and led to terminals on a metal base that permits the instrument to be pointed north and south at an appropriate angle. This catalog number covers two separate instruments which are marked "Sunshine Recorder, Type ML20, Signal Corps, U.S. Army, Serial 15 (40 in the second specimen), Order 110429, Date 5-5-23." Transferred from the Signal Corps in 1923. (Smithsonian photo 61837-F.)

Chapter 7

Sunshine Recorders

Instruments for recording the duration of sunshine can be divided into two distinct classes; those that make use of the heat of the sun, and those that employ its actinic effect.

The earliest of the first class, the so-called Campbell-Stokes sunshine recorder,¹⁵⁹ is used in many countries, but is not represented in the Museum's collection. In this instrument the sun's rays, collected by a sphere of optical glass, burn a track in a specially prepared card. It is really a sort of recording sundial. In the United States a sunshine recorder based on the differential thermometer of John Leslie,¹⁶⁰ and made into a recording instrument by D. T. Maring and C. F. Marvin,¹⁶¹ was adopted as standard at the stations of the Weather Bureau and the Signal Corps. The heat of the sun expands alcohol vapor in a blackened bulb, causing mercury to connect two platinum wires sealed into an inner tube.

¹⁵⁹ J. F. Campbell, *British Meteorological Society, Report of Council for 1857*, p. 18. G. G. Stokes, *Quarterly Journal Meteorological Society*, vol. 6 (1880), pp. 83-94.

¹⁶⁰ Leslie, *J. Nat. Philos., Chem., & the Arts*, vol. 3 (1799), pp. 461-67.

¹⁶¹ See Julien P. Friez, *Illustrated Catalogue of Meteorological Instruments and Apparatus . . .* (Baltimore, 1893), pp. 39-40. Also D. T. Maring, *Monthly Weather Review*, vol. 25 (1897), pp. 485-90.

The internal construction of this instrument is shown in figure 88, and its actual appearance in figure 89, which is a photograph of one of the two specimens in the Museum, MHT 308,176. This sunshine recorder is used in connection with the "triple register" or station meteorograph described in chapter 11.¹⁶²

The photographic recorder is fundamentally a pinhole camera, the image of the moving sun passing across a piece of sensitive paper, usually blueprint paper, as the day progresses. The first such instrument was invented by T. B. Jordan about 1838.¹⁶³ Two of the photographic recorders in the Museum are apparently experimental; they are numbered 248,689 and 248,690.

MHT 248,689. Photographic sunshine recorder. The nickel-plated tube (12.7 cm in diameter and 12 cm long) is mounted on a base with a scale of latitude so that the axis of the tube may be directed to the celestial pole. In lines parallel to the axis, and 90° apart, are two series of seven very small holes, which can be exposed one at a time by moving a dovetail slide having a single larger aperture. Inside the tube are

¹⁶² See pp. 123-24.

¹⁶³ T. B. Jordan, *Royal Cornwall Polytechnic Society, Annual Report for 1838* (Penzance, 1839), p. 184.

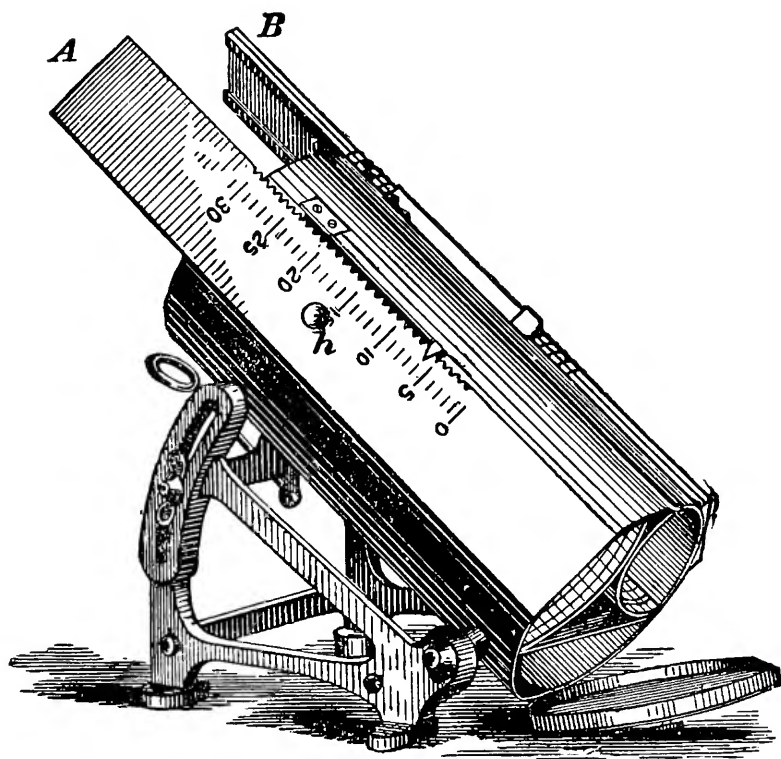

FIGURE 90

Diagram of a photographic sunshine recorder. Specimen MHT 314,539 has a metal tube (10.0 cm diameter and 18.5 cm long) mounted so that its axis can be directed to the celestial pole, a scale of latitude being provided. The tube is closed at its upper end, and a removable cap is provided at its lower end through which two pieces of photographic paper can be inserted and held by wire clips in sectors of cylinders back to back—one for morning, the other for afternoon. Along two sides of the main tube, at about 45° to the top, are fastened dovetail

slides with slots 13×0.3 cm. On these slides move brass pieces, $26.5 \times 38 \times 0.4$ cm, each with a small central hole and a scale reading 1 to 31. A serrated edge enables these slides to be set to correspond with the day of the month and held by means of a spring catch. One pair of record sheets thus suffices for a month's record. Each of the slides is marked "Julien P. Friez, Balto. Md. U.S. Weather Bureau N^o 55." Transferred from the Weather Bureau in 1954. (Diagram from Julien P. Friez's *Catalogue*, 1893, figure 24 on page 38.)

two cylindrical sectors back to back, with terminal grooves for holding pieces of photographic paper. By moving the slides, seven days' record can be obtained on the two pieces of paper. The push-on cover of the tube is marked "U.S.G.S." The instrument may be assumed to have been constructed by the U.S. Geological Survey from which it was transferred in 1908.

MHT 248,690. Experimental photographic sunshine recorder, consisting of a metal box, 12.5 x 6.5 x 7 cm, with a push-on cover. Two edges are beveled for 3 cm and contain tiny central holes. Inside the box, two quarter-cylinders receive pieces of photographic paper. The whole is supported on a hinged quadrant with a rough latitude scale, unnumbered. The

entire instrument is roughly constructed and has no markings. Transferred from the U.S. Geological Survey in 1908.

The third, MHT 314,539, figure 90, was designed by C. F. Marvin about 1890,¹⁶⁴ and still used by the Weather Bureau at some stations twenty years later.¹⁶⁵ When the hours of sunshine are counted, such instruments do not give the same results as the electrical sunshine recorder, and indeed it is very difficult to make sunshine recorders comparable.

¹⁶⁴ Op. cit. (footnote 112), pp. 38-39.

¹⁶⁵ C. F. Marvin, *The Care of Sunshine Recorders . . .*, U.S. Weather Bureau Circular G, 3d ed. (Washington, 1911), pp. 7-12.

Instrument not Referred to in the Text

MHT 314,714. A sunshine recorder of the differential-thermometer type, exactly as MHT 308,176 except for markings. Transferred from the Weather Bureau in 1955.



FIGURE 91

MHT 230,004. Fineman reflecting nephoscope. A glass plate 22 cm in diameter, blacked at the back, is engraved with concentric rings of 5 and 10 cm radius, and a diametral scale 10–0–10 cm, in millimeters. This can rotate about a central axis supported on three leveling screws and surrounded at a distance of 6 mm by an

annular scale of degrees 0–360. A telescoping post with a cross bar can rotate independently between the plate and the scale. This instrument is marked “Schneider Bros. New York” and bears the number “U.S.W.B. No. 50.” Transferred from the Weather Bureau in 1904. (Smithsonian photo 61836-C.)

Chapter 8

Nephoscopes

It was early seen that the direction of motion of a cloud could be determined by lining up a prominent feature of the cloud and some elevated terrestrial object, such as the top of a flagpole, and noting the position of the observer, who then moves in such a direction as to maintain the alignment. His direction of motion is then the exact opposite of that of the cloud. A refinement was introduced by L. Besson, who built an elevated “comb” that could be moved into any azimuth.¹⁶⁶ This also made it possible to determine the angular speed of the cloud by timing its motion between the “teeth” of the comb.

A neater solution had been devised by C. G. Fineman,¹⁶⁷ who provided a rotatable horizontal mirror provided with a suitable coordinate system, in which the cloud could be seen by reflection. There are two of these in the Museum, MHT 230,004 (figure 91) and MHT 316,153.

MHT 316,153. Fineman reflecting nephoscope, similar to MHT 230,004 except that it bears the number “U.S.W.B. No. 11.” It is badly corroded. Transferred from the Weather Bureau in 1959.

¹⁶⁶ L. Besson, *Ann. Soc. météorol. France*, vol. 45 (1897), p. 172.

¹⁶⁷ C. G. Fineman, *Zeits. für Instrum.*, vol. 6 (1886), pp. 206–8.

The potentialities of the application of modern technology are illustrated by comparison of the nephoscope with the meteorological earth satellite, TIROS, which enabled meteorologists to view in their entirety large-scale cyclones covering areas of more than 1500 km span. A backup satellite for TIROS I, launched on 1 April 1960, is included in the collections of the National Air and Space Museum.

NASM 1965–289. TIROS meteorological satellite, the name being an acronym for Television and InfraRed Observation Satellite. One of the first five built in 1959, the spacecraft is a 133 kg, 18-sided polygon, 107 cm in diameter and 56 cm high. Its sides and top are covered with 9,000 solar cells which, when exposed to the sun’s rays, recharge the spacecraft’s 63 Ni-Cd batteries. Protruding from the top of the satellite is a 46 cm receiving antenna which receives commands from ground stations. At the bottom are four 56 cm whip antennas spaced at 90° intervals, which transmit television pictures, infrared data and telemetry relating to spacecraft temperature, pressure, battery-charge levels, spin rate, etc. Two independent television camera systems capable of independent or simultaneous operation are aligned parallel to

the spacecraft's spin axis. Photographs of earth cloud are made on command. Each camera system consists of a vidicon tube and focal-plane shutter. Pictures are transmitted a maximum distance of 2,500 km. Magnetic tape storage allows up to 64 pictures to be recorded and stored until readout command is given. Infrared detectors measure earth radiant heat

on the night side of the earth providing data on land, ocean, and cloud albedo. The first TIROS was launched on 1 April 1960, into a near circular orbit of 750 km. TIROS I transmitted more than 22,500 pictures before its power supply failed. Transferred by the National Aeronautics and Space Administration to the Smithsonian's National Air and Space Museum.

Chapter 9

Upper-Air Instruments, Not Telemetering

While the scientific study of the weather began in the 17th century with the invention of the barometer and thermometer, its scope was severely limited until it became possible to make measurements in the free air, beyond the reach of structures built on the ground. The invention of the balloon in 1783 provided the possibility of making sporadic observations of this sort, but another century had to pass before the progress of instrumentation allowed fairly regular observations on a planned schedule, using kites, unmanned balloons, and aircraft.

The close relation between aeronautics and meteorology is symbolized by a number of instruments preserved in the Smithsonian's National Air and Space Museum.

NASM 1963-27. Mercury barometer carried during his balloon ascents of 1784 and 1785 by Dr. John Jeffries of Boston. Soon after the news of the first manned balloon ascent was made (de Rozier and d'Arlandes in a Montgolfière hot-air balloon, over Paris, 21 November 1783) Dr. Jeffries, then in England, arranged with the French aeronaut Jean Pierre Blanchard to make an ascent from London, on 30 November 1784. This is believed to be the first manned ascent in which instruments were carried

for determining weather conditions in mid-air. The following 7 January Jeffries and Blanchard ascended from Dover and were wafted across the Channel, landing in the forest of Guines. That was the first air voyage from one nation to another. This instrument (with a thermometer, see page 39) was carried on both of these ascents by Dr. Jeffries. The barometer, marked "James & Son, London," has the dimensions 87.5 x 11.5 cm. Presented by Dr. James Means.

NASM 1964-673. Mercury barometer carried during his balloon ascents by Charles Ferson Durant (1805-1873). Durant is generally considered the first professional aeronaut in the United States. His first ascent was made from Castle Garden, New York City, in 1830. The instrument is marked "Globe Portable Barometer, L. Roach, maker, New York." Its dimensions are 90 x 4.5 cm. Presented by Mrs. Louis C. Jones.

NASM 1931-40. Mercury barometer with thermometer, carried during his Civil War balloon ascents by Professor Thaddeus S. C. Lowe, military aeronaut for the Federal Army, 1861-63. Marked "James Green, N.Y." Overall dimensions, 96 x 2 cm. Presented by the heirs of T. S. C. Lowe through Mrs. Henry M. Brownback.

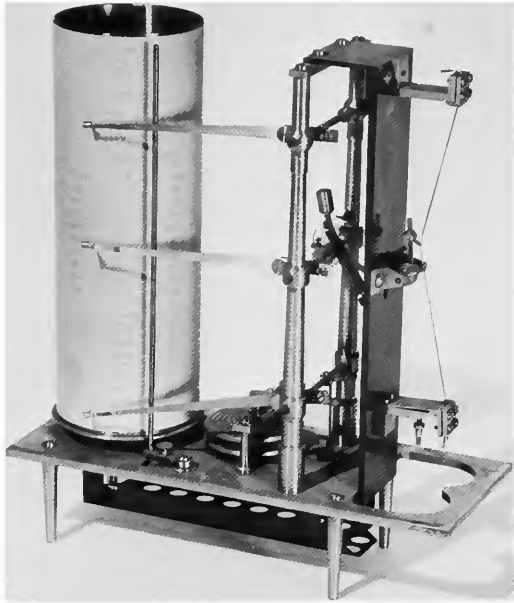

FIGURE 92

MHT 308,209. Original Richard meteorograph for captive balloons. On a brass plate 22 x 9.3 x 0.4 cm are mounted two strong brass posts to support the axes of three pen arms, operated by an aneroid barograph, a hair hygrometer, and a thermograph with a Bourdon tube in a perforated brass duct beneath the baseplate. The records are made in ink on a chart carried by a clock-driven drum 6.8 cm in diameter and 19 cm high. There is no fixed pen. The overall height of the instrument is 25 cm. The baseplate is marked with the Richard Frères monogram and "81970." Transferred from the Signal Corps in 1923. (Smithsonian photo 48467-H.)

Between about 1890 and 1940 many specialized meteorographs were designed to suit the characteristics of the various vehicles, and a few of these are represented in the collection. After 1940 these were abandoned in favor of the radiosonde, which will be discussed in the next chapter.

Meteorographs for Use With Kites or Captive Balloons

The heyday of meteorological kite flying and captive ballooning was the period between 1900

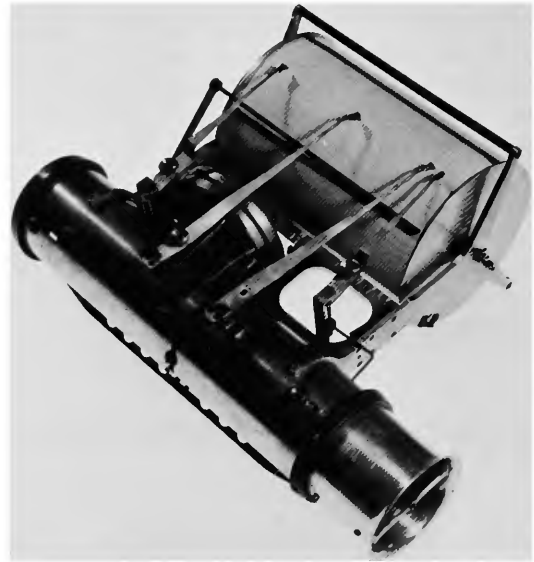

FIGURE 93

MHT 316,156. Marvin kite meteorograph, later pattern with windmill anemometer, aneroid barometer, bronze-invar bimetal, and a bundle of 8 hairs. It records on a drum 9.5 cm in diameter and 14 cm long, with an internal clock. The aluminum case is 23 cm long, 24 cm high, 13 cm in diameter at the smaller end and 18 cm at the larger. MHT 316,156 includes two identical instruments, both transferred from the Weather Bureau in 1959. A third meteorograph in the Museum (58294-N, Division of Naval History) was reputedly flown by Richard E. Byrd, U.S.N., over both the North and South Poles in 1926 and 1929 respectively. (Smithsonian photo 61836-A.)

and 1914, though at one or two places systematic observations were continued until shortly before the second World War.¹⁶⁸ Systematic measurements of the upper atmosphere by means of meteorographs raised by kites were begun in 1894 at the Blue Hill Observatory near Milton, Massachusetts.¹⁶⁹ Abbott Lawrence Rotch, who

¹⁶⁸ For an account of the very elaborate installations developed in Germany, see *Handbuch der meteorologischen Instrumente*, E. Kleinschmidt, ed. (Berlin, 1935), pp. 474-516.

¹⁶⁹ *Ann. Astron. Obs. Harvard College*, vol. 42, part 1 (1897), pp. 41-42.

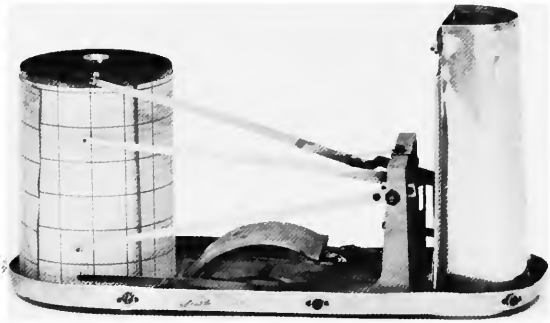
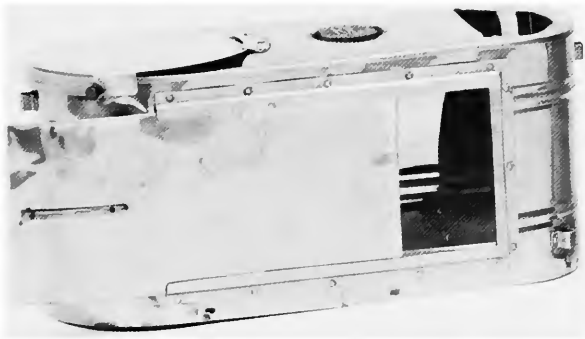

FIGURE 94

MHT 319,822. Fergusson sounding-balloon meteorograph, recording on a clock-driven drum covered with smoked aluminum foil. Three styli are moved by a Bourdon barometer, a bimetallic thermometer, and a hair. It is in an aluminum case with rounded ends, 21 cm long, 8.3 cm high, 8.2 cm across at the larger end and 5.7 cm at the smaller, with an opening that can be closed by an aluminum slide. It bears a label "Friez Baltimore Reg. U.S. Patent Office." Transferred from the Weather Bureau in 1962. (Smithsonian photo 61837-A.)

had founded the Blue Hill Observatory, and later bequeathed it to Harvard University, suggested to Richard Frères of Paris the construction of a special light aluminum meteorograph for kites, on the same general plan as a specimen in the Museum, MHT 308,209 (figure 92), which is of brass and was intended for use with captive balloons. This instrument was the parent of dozens of later designs for use with kites, captive balloons, sounding balloons, and aircraft.

By 1898, the U.S. Weather Bureau had established 16 kite stations in various parts of the country.¹⁷⁰ For these, C. F. Marvin, a noted authority on instruments and later Chief of the Bureau, designed the very successful meteorograph which bears his name.¹⁷¹ Richard

Assmann of Lindenberg, in Germany,¹⁷² and W. Köppen of the Deutsche Seewarte¹⁷³ both preferred the Marvin Meteorograph to that of Richard, and Assmann had it copied by a German maker. He also put a fan anemometer in the duct, a feature later added by Marvin, and present in two of the instruments in the Museum (MHT 316,156, figure 93), which also have bimetallic thermometers instead of the steel Bourdon tubes in the first design.

Meteorographs for Use With Free Balloons (Sounding Balloons)¹⁷⁴

The height attainable with captive balloons or kites is limited to a few kilometers, and free

¹⁷⁰ Donald R. Whitnah, *A History of the United States Weather Bureau* (Urbana, Illinois: University of Illinois Press, 1961), p. 101.

¹⁷¹ C. F. Marvin, *Instructions for Aerial Observers*, U.S. Weather Bureau, Circular K, Instrument Division (Washington, 1898).

¹⁷² Assmann, *Arbeiten Obs. Lindenberg*, vol. 7 (1912), p. XXIII.

¹⁷³ Köppen, *Archiv. dtsh. Seewarte*, vol. 24 (1901), pp. 96-98.

¹⁷⁴ The term *ballon-sonde* was introduced in France about 1895.

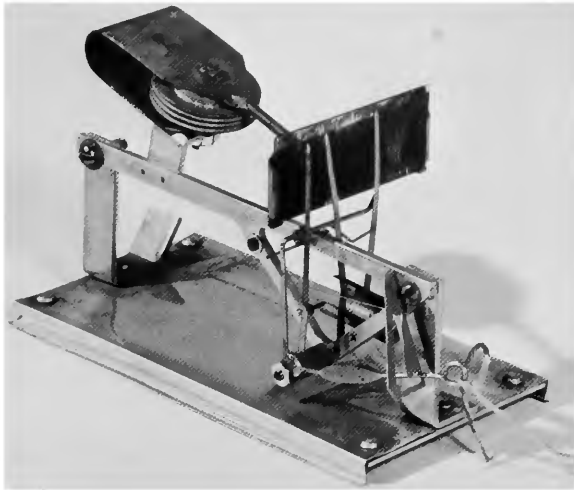

FIGURE 95

MHT 319,823. Jaumotte sounding-balloon meteorograph. A small surface of smoked glass is moved by the aneroid barometric element, while a bimetal and a hair move styli in a direction approximately at right angles to the movement of the surface. An aluminum-painted cloth cover 18.5 x 8.0 x 6.0 cm acts as a combined duct and radiation shield. The cover is labeled "USWB 1938 79." Transferred from the Weather Bureau in 1962. (Smithsonian photo 48467-E.)

balloons, carrying appropriate instruments, were used as early as 1892 by Gustave Hermite in France.¹⁷⁵ At first the balloons used were made of paper or goldbeater's skin, but about 1900 Assmann entirely changed the technique by the introduction of closed rubber balloons,¹⁷⁶ which have the great advantage that they continue to ascend at a fairly constant speed until they burst.

Naturally, it was important to reduce the weight of the apparatus, and many highly ingenious meteorographs were devised, both with and

¹⁷⁵ Hermite, *Compt. Rend. Acad. Sci.*, vol. 115 (1892), pp. 862-64.

¹⁷⁶ *Int. Aeronaut. Comm., Berlin, 1902, Verhandlungen*, pp. 81-83.

without clocks.¹⁷⁷ Of the former kind, the Museum has an example, MHT 319,822, figure 94, of the meteorograph designed by S. P. Fergusson in 1919.¹⁷⁸

No matter how they are lubricated, clocks give trouble at very low temperatures. It was therefore natural to save the trouble and the weight of a clock by making the instrument plot temperature and humidity against pressure. A very successful meteorograph of this type, used for over twenty years in Great Britain, was devised by W. H. Dines and developed in the years 1906 to 1909.¹⁷⁹ This made very fine lines on a surface of polished metal, the record being read off with the aid of a special microscope. There were other related designs, arising in various countries. At the Museum the type is represented by two examples of the Jaumotte meteorograph.¹⁸⁰ The first, MHT 319,823, without its cover of aluminum-painted cloth, is shown in figure 95; the other is MHT 322,321.

MHT 322,321. Jaumotte sounding-balloon meteorograph, similar to MHT 319,823. The cover is marked "USWB 1938." Transferred from the Weather Bureau in 1963.

Meteorographs for Use On Aircraft

Between the wars, small aircraft were used regularly in many places to make soundings up to heights of 6 or 8 km. The meteorographs used on these flights, usually attached by shock cords between the wings of the biplanes common at the time, were almost all strengthened versions of either the Marvin or the Richard kite

¹⁷⁷ See K. Keil, *Über Meteorographen für aerologische Zwecke* (International Meteorological Organization, Berlin, 1938), for many examples of each.

¹⁷⁸ Fergusson, *Monthly Weather Review*, vol. 48 (1920), pp. 317-22.

¹⁷⁹ *Collected Scientific Papers of William Henry Dines* (London, 1931), pp. (180) and (183)-(216).

¹⁸⁰ J. Jaumotte, *Mem. Acad. roy. Belgique*, no. 1417 (1931), 44 pp.

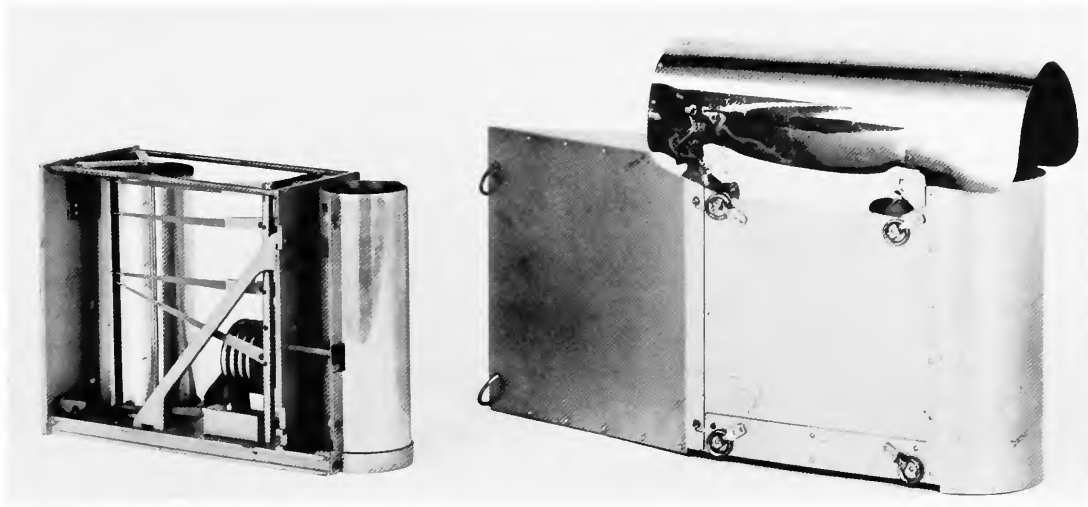

FIGURE 96

MHT 322,305. Aircraft meteorograph. This is effectively the Calwagen instrument, with a different arrangement of the aneroid, which has four chambers, apparently with internal springs. The thermometer is a bimetal, the hygrometer a bundle of hairs. There is a time marker on the pen that draws the base line. The drum measures 7 x 17 cm; the case is 21 cm high, 10.5 cm wide, and 44 cm long overall. Marked "Gebrüder Winter Jungingen Hohenz No. 4659N." Transferred from the Weather Bureau in 1963. (Smithsonian photo 61836-D.)

meteorograph,¹⁸¹ usually with some arrangement for reducing the speed of the air past the thermometer and hygrometer. A typical example is that of Calwagen.¹⁸² The Museum has four aircraft meteorographs, three of them of the type derived from the Richard instrument. Figure 96 shows one of these, MHT 322,305. Two of these instruments, not illustrated, are:

MHT 322,306. Aircraft meteorograph. Almost identical with MHT 322,305, but made by Bosch & Bosch. Damaged. Has a detachable conical frustum to put at the end of the duct for reducing the flow of air. Marked "Bosch & Bosch Präzisions-Mechanik Freiburg i. Br. 4024N." Transferred from the Weather Bureau in 1963.

MHT 322,307. Aircraft meteorograph marked "Julien P. Friez & Sons Inc. Belfort Meteorological Observatory, 1230 E. Baltimore Street, Baltimore, Md." and "Aero 1931 U.S.W.B. No. 82." This is the Friez version of the Richard kite meteorograph, made stronger for aircraft use, and with an aneroid bellows instead of a Bourdon tube. The hygrometer is a "harp" of hairs, the thermometer a bimetal. There is a base-line pen with provision for making time marks by means of an electromagnet. A clock beneath the base drives a drum 6.8 cm in diameter and 19 cm high. The brass case is 22 cm long, 9.8 cm wide, and 25 cm high, and is rounded at its leading edge. There is provision for suspending it by eight shock cords. Transferred from the Weather Bureau in 1963.

The fourth is an incomplete instrument with some features of design that are hard to account for after the lapse of three decades.

MHT 322,309. Aircraft meteorograph marked "Friez Baltimore" and "U.S.W.B. 1935 No. 36." Incomplete. Evidently recorded on a roll of paper, but only the take-up roll exists. The

¹⁸¹ See Keil, *Über Meteorographen für aerologische Zwecke*, for details.

¹⁸² E. G. Calwagen, *Geophysische Publikationen*, vol. 3 (1926), no. 10, p. 5.

pressure, temperature, and humidity pens have collinear axes. Transferred from the Weather Bureau in 1963.

Miscellaneous Apparatus Used in Connection With Upper-air Observations

MHT 308,202. Metal scale for use in plotting the tracks of balloons, 77 cm long, with two projecting bosses, each having a hole centered on one edge of the scale. Graduations 0–150 (fifths of an inch) on one edge, 0–100 on the other. Divisions in tenths of an inch. Not identified. Transferred from the Signal Corps in 1923.

MHT 316,152. Valve for the purpose of letting the gas out of a balloon when a certain altitude is reached. It operates on the principle of the aneroid barometer, with a brass bellows. Overall length 23 cm. Marked "Weather Bureau Ellendale N. D." Transferred from the Weather Bureau in 1959.

MHT 316,154. Aluminum balloon valve actuated by the expansion of the balloon. The valve is 2.5 cm in diameter and 5.7 cm long. Transferred from the Weather Bureau in 1959.

MHT 316,272. Japanese set of weights for filling balloons to a given free lift. These are for large balloons with necks that can be tied around grooved disks with diameters 9.8 or 12.0 cm. These disks may be screwed to fittings with hose connections and stopcocks, ballasted by hollow metal cylinders of marked weights into which loose cylindrical weights may be inserted. They are in a fitted wooden case 38 x 23 x 10 cm. Transferred from the Weather Bureau in 1959.

MHT 316,811. Plated metal sphere 30 cm in diameter, with a smaller concentric sphere inside. Stated to be for the storage of helium. There are two taps, a boss with a screwed cap, and three other openings, one connected by a tube to the internal sphere. A ring stand of iron, 30 cm in diameter, is provided. Transferred from the Weather Bureau in 1959.

Chapter 10

Radiosondes

The instruments described in chapter 9 were able to furnish a great deal of information about the upper air, but only after much delay and, in the case of sounding balloons, on the assumption that they would be found and returned. The possibility of obtaining such information at once only appeared with the refinement of the techniques of radio communication, especially with relatively short waves. This, to a large extent the work of amateur operators who were being prevented from using the longer waves because of the growth of broadcasting, began in the early 1920s. In a radiosonde, a change of atmospheric condition causes a change in the transmitted radio signal. This is accomplished in four different ways:

- Employing a time cycle;
- Sending a coded signal;
- Varying the radio frequency;
- Varying the audio frequency.

All four types of radiosondes are represented in the Museum's collections.

The immediate ancestors of the radiosonde, nevertheless, were instruments developed in France and in Germany during the war of 1914–1918 for transmitting information down a kite wire. In 1917, Friedrich Herath and Max Robitzsch replaced the recording drum of a kite meteorograph with an insulating cylinder revolving once every six minutes; two metal strips

were inserted into this as in figure 97, one parallel to the axis of the drum, the other forming a helix.¹⁸³ When the styli of the meteorological instruments made contact with these strips, the primary of a small spark coil was energized, the secondary of which was connected across a spark gap in the kite wire in parallel with a capacitor. At the ground, a telephone receiver between the kite wire and the earth was used to listen to the signals. In France at about the same time, Pierre Idrac used tuned circuits for both transmitter and receiver in this sort of carrier telegraphy, noting that several radio frequencies could easily be used simultaneously.¹⁸⁴

In the Herath and Robitzsch instrument, the reading of each meteorological element had a one-to-one relation with the time between two signals, assuming a uniform rotation of the drum. This principle, which has been used in a number of radiosondes, really dates back to 1874, when E. H. von Baumhauer of Haarlem designed a

¹⁸³ Manuscript, cited by P. Duckert, *Beitr. Phys. freien Atm.*, vol. 18 (1932), pp. 73–4. This ms. seems to have been lost (according to a private communication from Dr. Karl Keil). Note that the axial wire could have been replaced by a fixed contact.

¹⁸⁴ E. Rothé, *Compt. Rend. Acad. Sci., Paris*, vol. 170 (1920), pp. 1197–98.

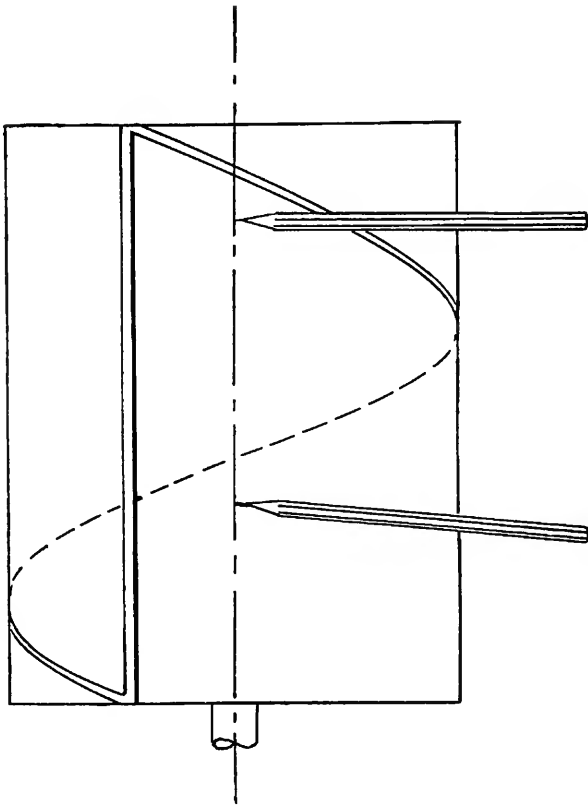

FIGURE 97

Diagram of the telemeteorograph of Herath and Robitzsch.

telemeteorograph of this sort for use on land.¹⁸⁵ A different apparatus on the same principle was built by the Dutch instrument maker H. Olland¹⁸⁶ after reading Baumhauer's paper, and from that time onward such instruments have been said to operate on the "Olland system." It is more just to refer to them as time-cycle instruments. It should be made clear that the helix can be, and at various times has been, replaced by a flat plate with a radial conducting line, or by a

¹⁸⁵ Baumhauer, *Archives Néerlandaises*, vol. 9 (1874), pp. 230-58.

¹⁸⁶ For more information on Olland, see M. Snellen, *Arch. Néerl.*, vol. 14 (1879), pp. 180-208.

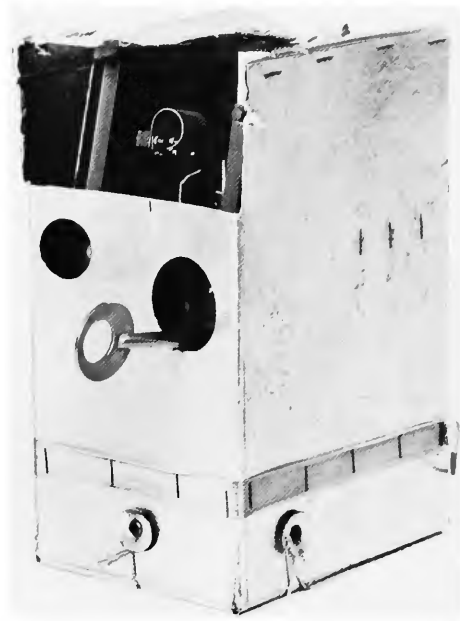

FIGURE 98

MHT 319,827. Radiosonde of the Robert Bureau type, built about 1932. It is marked "Constructeurs Mécaniques et Electriques P. de Presale 104-106, Rue Oberkampf, Paris (XI^e) Type PTU," and has the serial number 3567. It is in an aluminum-painted box 27 x 16 x 13 cm; the vacuum tube and the batteries are missing. Transferred from the Weather Bureau in 1962. (Smithsonian photo 61837-D.)

conducting equiangular spiral. The essential feature is the variation of the time between contacts as the meteorological elements vary.

Experiments with radio communication from a free balloon to the ground seem to have begun in Germany and the U.S.S.R. in the early 1920s,¹⁸⁷ but the first open publication known to the writer came from France, where on 7 March 1927, a 4-watt transmitter was heard from high in the stratosphere.¹⁸⁸ Idrac and

¹⁸⁷ Moltchanoff, *Gerlands Beitr. Geophys.*, vol. 34 (1931), pp. 36-56; Hergesell, in *Beitr. Phys. freien Atm.*, vol. 18 (1932), p. 50.

¹⁸⁸ P. Idrac and R. Bureau, *Compt. Rend. Acad. Sci.*, vol. 184 (1927), pp. 691-92.

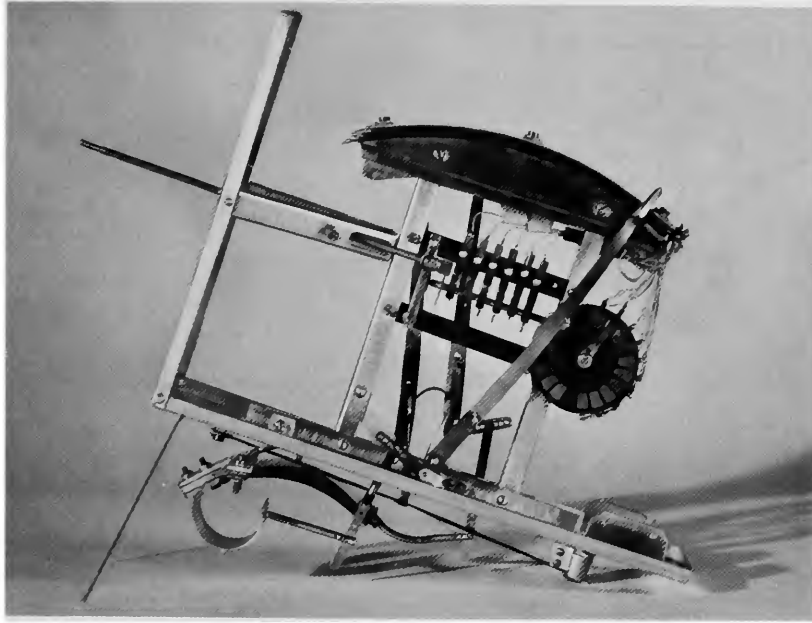

FIGURE 99

MHT 316,262. Mechanical parts of a Moltchanoff radiosonde, apparently the later type, but if so, incomplete. In this instrument, a series of six star-shaped cams with various numbers of points is operated by a windmill through gearing. The choice of the cam which makes contact at a given moment is made by a second switch operated by the appropriate meteorological instrument—a Bourdon-tube barometer, a bi-

metal thermometer, and a bundle of hairs. The windmill also operates a flat insulating disk with 3 + 10 switch points and a switch arm. This forms part of the humidity circuit and has other functions. The instrument, made of aluminum, measures 21 cm long x 6 cm wide x 23 cm high, exclusive of the windmill. It bears the number 39097. Transferred from the Weather Bureau in 1959. (Smithsonian photo 48467-A.)

Robert Bureau immediately began the development of a radiosonde, making their first ascent on 17 January 1929,¹⁸⁹ with a time-cycle device transmitting indications of temperature and pressure. In May 1930, Robert Bureau, who introduced the term *radio-sonde*, wrote a paper¹⁹⁰ in which he explored fully and logically the various possible ways of modulating or altering a radio signal so as to transmit meteorological information. The Museum has an example, (figure 98) of one of the later French radiosondes developed under Bureau's direction in the 1930s (MHT 319,827). The distinguishing

feature of this time-cycle radiosonde is in the means adopted to make it unnecessary for the clock to keep an exactly uniform rate of rotation. A toothed wheel is geared to the rotating cylinder of the time-cycle mechanism; this wheel forms one plate of a small capacitor in the LC circuit of the transmitter, and produces a frequency modulation of the signal, giving records with a number of "pips" that is a function of the pressure or temperature, followed by a blank space.

The next radiosonde to be publicly described was that of Pazel A. Moltchanoff.¹⁹¹ In this both

¹⁸⁹ Bureau, *Compt. Rend. Acad. Sci.*, vol. 188 (1929), pp. 1565-66.

¹⁹⁰ *La Météorologie*, vol. 7 (1931), pp. 304-17.

¹⁹¹ Moltchanoff, *Gerlands Beitr. Geophys.*, vol. 34 (1931), pp. 36-56.

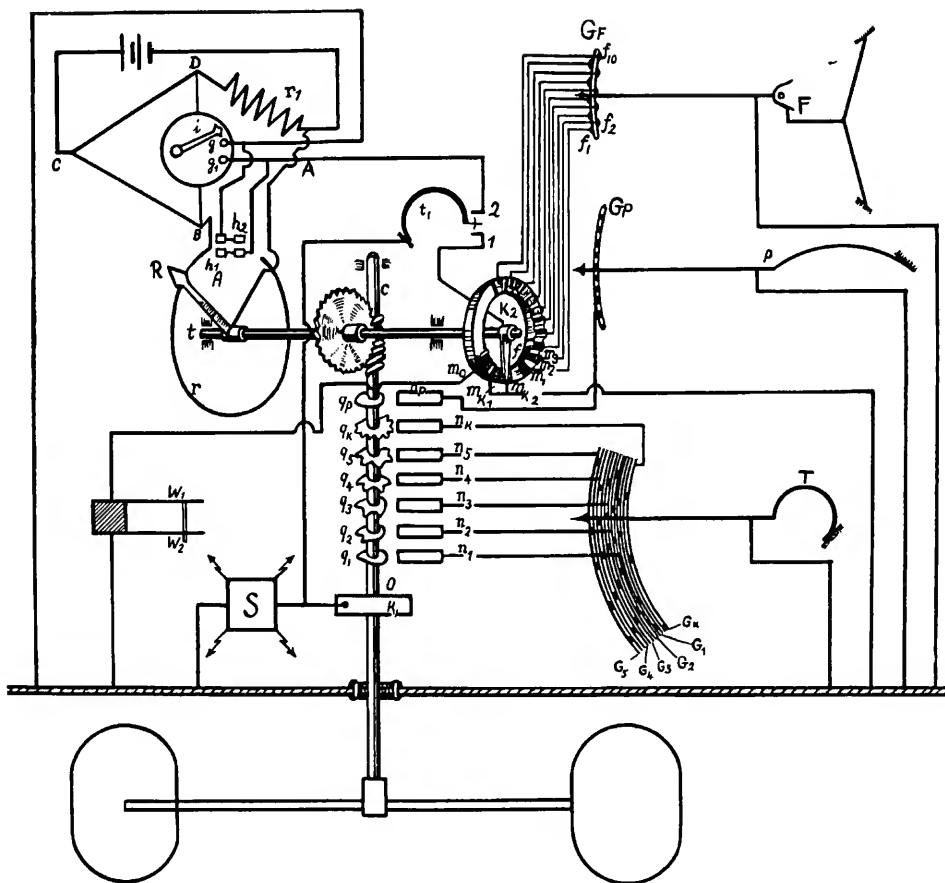

FIGURE 100

Diagram of Moltchanoff's circuit, 1936. (Figure 27 on page 45 in the International Meteorological Organization, Aerological Commission, *Über Radiosonde-Konstruktionen*. Denkschrift, Berlin, 1937; Smithsonian photo 63880.)

temperature and pressure are transmitted in steps by two arms, each making contact with an assembly of metal strips looking somewhat like a comb, which has led to the term *Kammergerät* for such instruments. The mechanical part of a later Moltchanoff radiosonde¹⁹² is in the Museum (MHT 316,262) and is pictured in figure 99.

Moltchanoff's elaborate circuit of about 1936 is shown in figure 100,¹⁹³ and the reader must be

¹⁹² See L. Weickmann, ed., *Über Radiosonde-Konstruktionen*. Denkschrift (International Meteorological Organization, Berlin, 1937), pp. 45-54.

¹⁹³ *Ibid.*, p. 45.

referred to the published account for a fuller description. It should be noted, however, that a platinum resistance thermometer with a Wheatstone bridge is switched in, and the hygrometer switched out, at about -20° C, and that there is a device to indicate the emergence of the radiosonde from the top of a cloud deck.

Meanwhile, Paul Duckert at Lindenberg in Germany was working on a radiosonde of still another type, one in which the capacitance of an oil-filled condenser, and thus the radio frequency put out by the transmitter, was controlled by the temperature—actually by a bimetal that moved one of the condenser plates—while

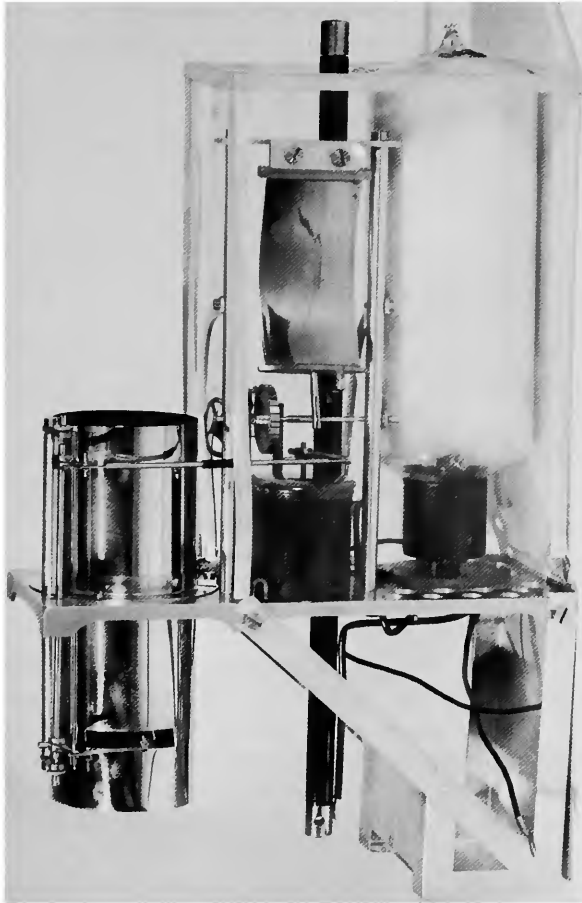

FIGURE 101

MHT 313,527. Duckert radiosonde of the later form (1932) with the entire radio circuit, except for a variable condenser operated by a bimetal, enclosed in a vacuum tube 6 cm in diameter and 16 cm long. A gold-plated toothed wheel, turned by a Bourdon tube, switches between the variable capacitor and a fixed one at known values of pressure. Overall dimensions at 16 cm x 8.5 cm x 31 cm high. Transferred from the Bureau of Standards in 1950. (Smithsonian photo 48467-C.)

pressure was indicated intermittently by means of interruptions of the signal, effected by contacts moved by a Bourdon-tube barometer.¹⁹⁴ Later, the Telefunken firm improved this radiosonde by sealing the entire radio circuit, except for the temperature-sensitive condenser, in an evacuated bulb. In this model (represented in the Museum collections by MHT 313,527, figure 101), the pressure switch did not interrupt the

signal, but switched from the variable capacitor to a fixed one in order to provide a reference signal as a check on the stability of the transmitter.¹⁹⁵ Still later¹⁹⁶ the thermometer was greatly improved by replacing the oil-filled variable condenser by a simple capacitor having a large temperature-coefficient of dielectric constant. Means were also found to transmit indications of the relative humidity in the form of variations in the length of time for which the reference frequency is turned on.

In the first years after 1930 there were a number of designs of time-cycle radiosonde, some of which are represented in the Museum. The earliest was suggested by Moltchanoff and developed, rather elaborately and expensively, by the Askania-Werke in Germany.¹⁹⁷ Later, a much simpler instrument, invented by A. Lang and developed

¹⁹⁴ P. Duckert and B. Thieme, *Beitr. Phys. freien Atm.*, vol. 18 (1932), pp. 50-67.

¹⁹⁵ Duckert, *Beitr. Phys. freien Atm.*, vol. 20 (1933), pp. 303-11.

¹⁹⁶ *Op. cit.* (footnote 192), pp. 25-27.

¹⁹⁷ *Ibid.*, pp. 16-25.

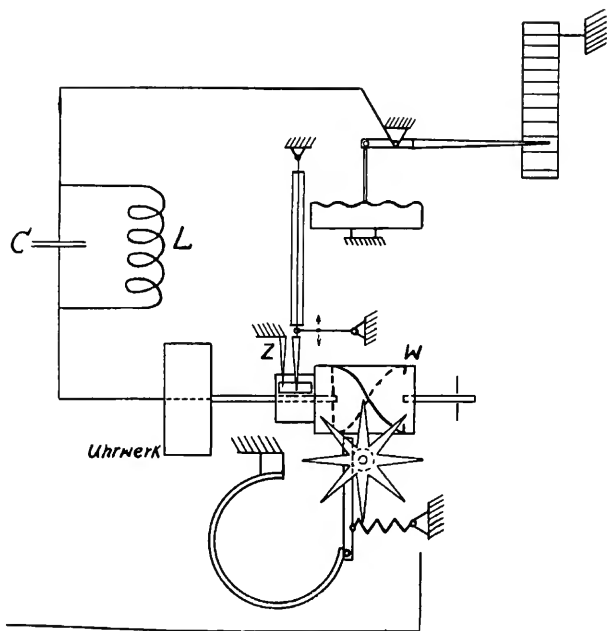

FIGURE 102

Diagram of the Lang—Reichsamt für Wetterdienst radiosonde. (Figure 9 on page 28 in the International Meteorological Organization, Aerological Commission, *Über Radiosonde-Konstruktionen. Denkschrift*, Berlin, 1937; Smithsonian photo 63882.)

by the German Weather Service, was used for several years in Germany.¹⁹⁸ Its general scheme is shown in figure 102. A clock drives two coaxial insulating cylinders, one having two conducting helices and the other a broad conducting band parallel to the axis. Instead of operating just one contact, the bimetal turns a star wheel, thus greatly expanding the temperature scale of the instrument. The hair moves a contact which, together with a fixed contact, shuts off the transmitter once a revolution for a length of time depending on the relative humidity. The aneroid chamber operates a switch that interrupts the signal at known values of pressure. The Museum has several specimens of which MHT 322,311 is the most nearly complete (figure 103).

¹⁹⁸ *Ibid.*, pp. 28–30.

This radiosonde uses the time-cycle principle for temperature and humidity, not for pressure; however, in the United States and Canada several attempts were made to use the time-cycle principle for all the elements. An institution early in this field was Blue Hill Observatory of Harvard University, one of whose radiosondes—not the earliest—is represented, though not completely, by MHT 322,325. The instrument of which this formed a part is shown in figure 104.

The radiosonde developed by the Guggenheim Aeronautics Laboratory of the California Institute of Technology (GALCIT) has a double-ended contact arm that touches contacts moved by the barometer, thermometer, and hygrometer, as well as two fixed reference contacts, twice each minute.¹⁹⁹ The specimen in the Museum (MHT 319,828) lacks the tiny lead-acid storage batteries that operated the transmitter.

MHT 319,828. Radiosonde, marked “Galcit USWB No. 430.” An aluminum radiation shield 5.6 x 4.8 x 10 cm long contains two aneroid chambers, a curved bimetal, and a bundle of hairs. These operate contact arms that pass through a slot to a box containing a contact rotated by a special clock. The latter is in a transparent plastic cover. An A-frame holds a small radio transmitter, using an acorn tube, at a distance of about 10 cm from the rest of the instrument. The batteries are missing. Transferred from the Weather Bureau in 1962.

The motion of any clockwork is discontinuous, and both the Blue Hill and GALCIT radiosondes used special clocks with more ticks per minute than the ordinary watch, so as to reduce the “least count” of the meteorological instruments. To produce completely uninterrupted motion, the U.S. Weather Bureau made experiments with a tiny air turbine, supplied from a small balloon filled with air, while L. F. Curtiss²⁰⁰ developed a small electric motor for the same purpose, which, with the other mechanical parts of a radiosonde, is in the Museum

¹⁹⁹ Sec O. C. Maier and L. E. Wood, *J. Aeron. Sci.*, vol. 4 (1937), pp. 417–22.

²⁰⁰ *Bulletin American Meteorological Society*, vol. 18 (1937), p. 391.

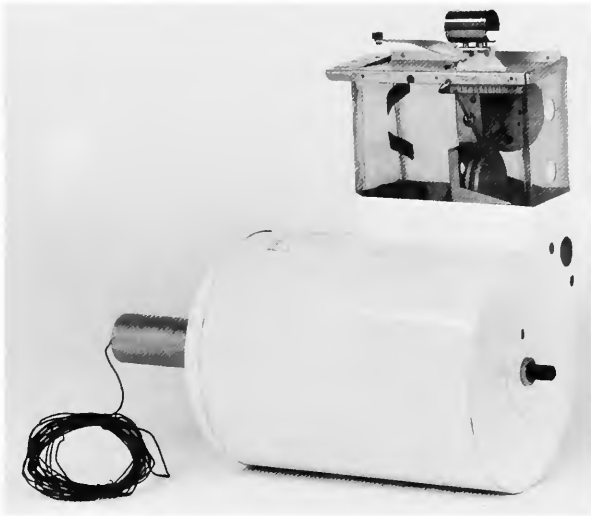

FIGURE 103

MHT 322,311. Lang—Reichsamt für Wetterdienst radiosonde, apparently complete except for batteries, hygrometer, and radiation shield for the bimetal. This bimetal turns an 8-pointed star wheel, one of whose points makes contact with two conducting helices in an insulating cylinder. A fixed contact and one operated by a hygrometer connect with a conducting band parallel to the axis of a smaller portion of the cylinder. The 2-chamber aneroid traverses a switch arm over a raster of unequally spaced lines, giving contacts not far from linear in pressure. All this is an appendage to a white plastic case 16 cm in diameter and 21 cm long, which contains an extremely well-constructed and elaborate radio apparatus, with four vacuum tubes. The instrument is marked "W.S.E. 2 Gerät Nr. 124 75A Anf. Zeichen Ln 28790," and is accompanied by calibration sheets. Transferred from the Weather Bureau in 1963. (Smithsonian photo 61836.)



FIGURE 104

MHT 322,325. Blue Hill radiosonde, type F, of 1936. The small bimetal, in a radiation shield 2 cm in diameter and 6 cm long, the hair, and the aneroid, move contact arms along a thin cylinder having a helical conducting wire of three turns let into its surface. The shaft carrying this helix protrudes through the top of a light wooden box, intended to contain a clock, a radio transmitter, and batteries. The box measures 18 x 10 x 7 cm. There is a semicircular aluminum shield for the mechanical parts, and a label reading "Feiber Instrument Co. Cambridge, Mass. U.S.A.," with the serial number "850." Transferred from the Weather Bureau in 1963. (Figure 5 on page 117 in *Bulletin American Meteorological Society*, vol. 18, 1937.)

(MHT 319,830), as is another experimental instrument by Curtiss and Astin, in which a helix has replaced the contact rotating in a plane (MHT 319,833). A spiral, and an improved electric motor stabilized by a weighted reed,²⁰¹ was later used by Jacobsen in Canada in a radiosonde that gave good service for two decades.

MHT 319,830. Curtiss—Astin radiosonde, mechanical parts. A simple electric motor, in which a bar magnet, on a shaft with a cam-operated switch, gets impulses from a rectangular coil, drives a very light rotating contact through gearing. This contact touches arms moved by an aneroid chamber, a bimetal, and a gold-beater's skin hygrometer, as well as two fixed contacts. The hygrometer is broken. The assembly is 19 cm long. Transferred from the Weather Bureau in 1962.

MHT 319,833. Curtiss—Astin radiosonde, experimental model. The transmitter is missing, but the cylindrical, corrugated cardboard box, 15 cm in diameter and 20 cm high, with walls 2.5 cm thick, contains an electric motor which drives a conducting helix through a shaft about 5 cm long. This shaft is in a bakelite tube 1.3 cm in diameter, which alone supports the meteorographs. There is an aneroid chamber, a bimetal, and a clamp with traces of goldbeater's skin. All this is mounted on a cylindrical aluminum frame 11.5 cm in diameter and 2.7 cm high. If there was any shielding it has disappeared. Transferred from the Weather Bureau in 1962.

The Julien P. Friez Company of Baltimore also used a spiral about 1936, but it was driven by a clock (MHT 319,832).

MHT 319,832. Experimental time-cycle radiosonde said by Mr. Christos Harmantas to date from 1936 and to have been designed by the Julien Friez Company. An octagonal wooden box, 15 cm across the flats and 14 cm high, contains a clock, batteries, and a radio transmitter that had two tubes (one is missing). The clock revolves a gold-plated spiral of only 2.0 cm maximum radius, and contact is made to this by gold wires moved by an aneroid bellows

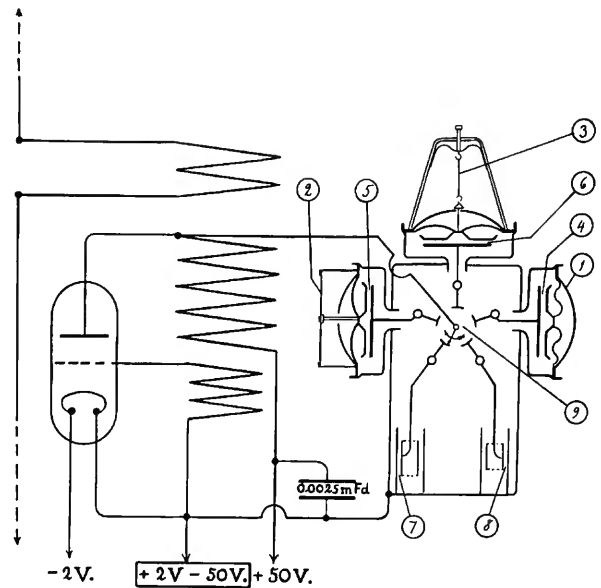

FIGURE 105

Diagram of the Väisälä radiosonde, 1937. (Figure 11 on page 31 in the International Meteorological Organization, Aerological Commission, *Über Radiosonde-Konstruktionen. Denkschrift*, Berlin, 1937; Smithsonian photo 638 81.)

only 1.9 cm in diameter, a straight bimetal, and a "harp" of hairs, as well as by two fixed wires. All this mechanism is mounted on an aluminum plate of complicated shape fastened to the end of the box and surrounded by two narrow aluminum rings, the inner one 12.6 cm in diameter which is held 1.5 cm away from the end of the box by posts. Transferred from the Weather Bureau in 1962.

Time-cycle radiosondes, which once looked so promising, have been almost completely superseded by instruments of other types, especially the variable-radio-frequency and the variable-audio-frequency radiosondes. The first instrument in which all the meteorological elements are telemetered in terms of radio frequencies was designed in 1932 by Vilho Väisälä of Helsinki.²⁰² In this, four capacitors were con-

²⁰¹ R. C. Jacobsen, *Rev. Sci. Instr.*, vol. 10 (1939), p. 315.

²⁰² *Soc. Sci. Fenn., Comm. phys.-math.*, vol. 6 (1932), no. 2.

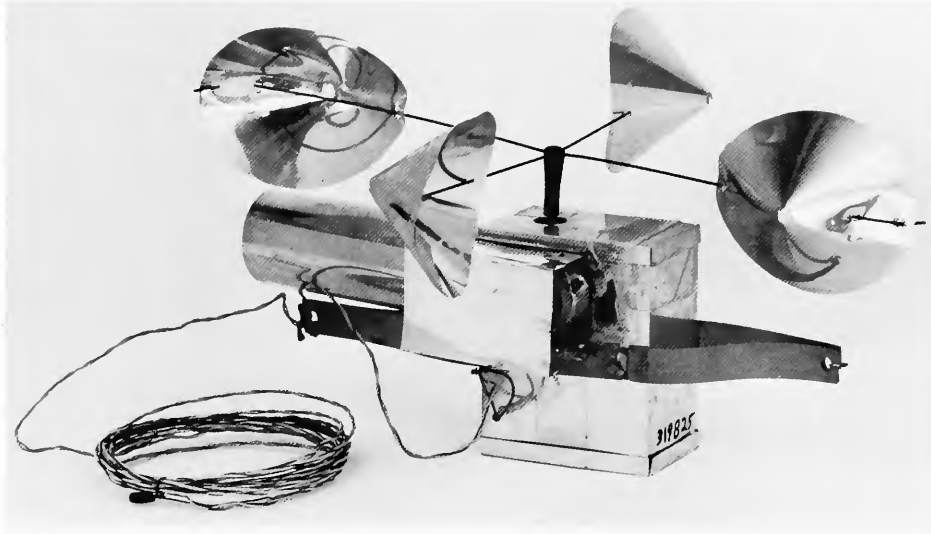

FIGURE 106

MHT 319,825. Väisälä radiosonde. A windmill of four conical cups puts five condensers successively into the transmitter circuit, three being controlled by the barometer, the metallic thermometer, and the hair hygrometer, the

others being fixed capacitances for reference. Apart from the windmill, the overall dimensions are 22 cm high, 11 cm long, and 9 cm wide. Transferred from the Weather Bureau in 1962. (Smithsonian photo 61837-C.)

nected successive'y into the LC circuit of an oscillator by a switch operated by a windmill. One was a fixed condenser to give a reference frequency, the others being varied by the meteorological instruments. Later, among other improvements, two fixed condensers were used,²⁰³ as in the diagram (figure 105). The instrument in the Museum (MHT 319,825) is shown in figure 106.

A Japanese radiosonde in the possession of the Museum has three separate radio transmitters, with attachments for three antennas, for pressure, temperature, and humidity, respectively (MHT 324,239).

MHT 324,239. Radiosonde of the type used by the Japanese Navy during the years 1943 to 1945. It has three vacuum-tube transmitters,

their frequencies varied individually by an aneroid barometer, a hair hygrometer, and a liquid-in-glass thermometer filled with a mercury-thallium amalgam. The barometer and hygrometer each move one plate of a variable air capacitor; but the thermometer (now broken and nearly all missing) had a metal sheath, and the capacitance between this and the amalgam in the tube varied with the temperature. The high-voltage supply is by means of a vibrator and transformer. The whole assembly is mounted on a white molding and enclosed in a cylindrical white plastic case, 11 cm in diameter and 14 cm high (incomplete), with terminals for three antennas (missing). Transferred from the Weather Bureau in 1964. (We acknowledge the kindness of Dr. Naosuke Arizumi of the Central Meteorological Agency, Tokyo, in providing information about this radiosonde.)

The Museum also has one of the several types of radiosonde devised during World War II by

²⁰³ Ibid., vol. 9 (1937), no. 9.

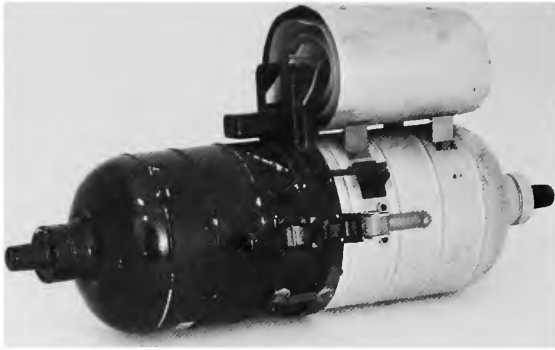

FIGURE 107

MHT 314,513. German radiosonde in which a pressure element and two thermometers—one covered with muslin—are used to vary the radio frequency of the signal. An electric motor is used to operate the switch that changes the connections among these and two reference capacitors. These last, as well as other parts of the transmitter, are in a light Dewar flask. The whole instrument except the thermometers is in a cylindrical aluminum case with hemispherical ends, 30 cm long overall and 8.4 cm in diameter. The thermometers are in an attached triple shield, consisting of an outer oval cylinder of aluminum and two concentric oval cylinders of white plastic. Presented in 1954 by Mr. Kenneth M. Perry of Falls Church, Virginia. (Smithsonian photo 69837-E.)

K. Sittle and E. Manzer.²⁰⁴ These are very neat adaptations of the variable-radio-frequency principle, with the interesting variation that temperature and humidity are measured by a psychrometer, the two thermometers being capacitors with temperature-sensitive dielectrics. There is a specimen in the Museum (MHT 314,513, figure 107).

By about 1936 it had been decided in the United States that a serious attempt, properly financed, must be made to design a radiosonde suitable for production in large quantities.

²⁰⁴ Bulletin American Meteorological Society, vol. 31 (1950), 341-46.

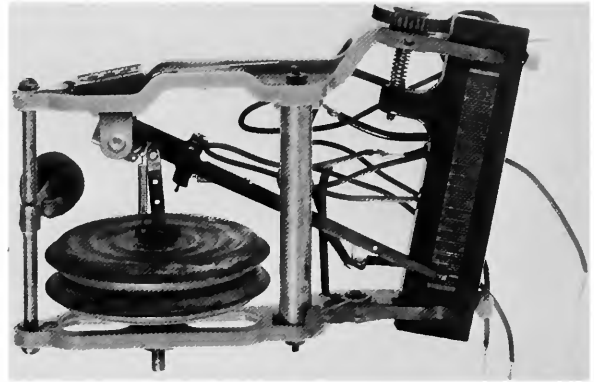

FIGURE 108

MHT 312,800. Early barometric switch for radiosonde. Marked "WIT" on plastic frame. Overall dimensions, 13 x 8.5 x 6 cm. Presented in 1944 by the Plaskon Co., Inc., Toledo, Ohio. (Smithsonian photo 61836-B.)

This task was entrusted to the National Bureau of Standards, where the researches of H. Diamond, W. S. Hinman, Jr., and F. W. Dunmore led to a solution of the problem that has been the basis of American radiosondes to the present day.²⁰⁵

Their rejection of the use of any sort of clock or motor, eliminated the time-cycle principle at once. Meteorologists expressed a preference for a record in which temperature and humidity appeared as functions of pressure; and this preference was of course supported by the expectation that as the balloon ascended, the pressure would always decrease in a smooth and featureless curve. They therefore provided what they called a "pressure drive," in which an arm operated by an aneroid barometer makes successive contacts at calibrated values of pressure, as in MHT 312,800 (figure 108).

For the transmission of the other elements, they decided to modulate the radio frequency signal at a rate of a few hundred cycles per second, and design the thermometer and hygrometer so as to produce a calibrated variation in

²⁰⁵ Bulletin American Meteorological Society, vol. 18 (1937), pp. 73-99.

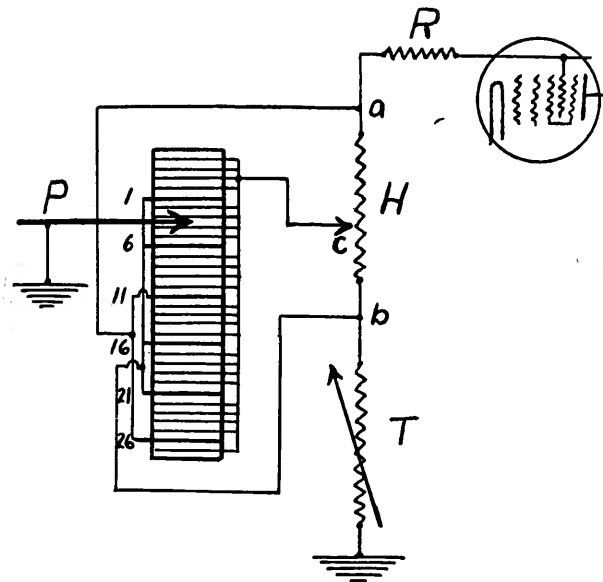

FIGURE 109

First circuit of Diamond, Hinman, and Dunmore. (Figure 2 on page 75 in *Bulletin American Meteorological Society*, vol. 18, 1937; Smithsonian photo 63263.)

this audio frequency. This was done by using a "relaxation," or RC, oscillator to modulate the signal, the resistance R of the circuit being varied by the changes in temperature or humidity. It should be noted that the use of a variable audio frequency had been mentioned as a possibility by Bureau in 1931.²⁰⁶

This principle of varying the frequency of modulation had considerable advantages over that of varying the radio frequency: it used up less of the crowded radio-frequency spectrum; it was almost immune to interference; and a signal of constant radio frequency is almost a necessity for direction finding.

Thus the thermometer and hygrometer had only to produce changes of electrical resistance. Assuming for the moment that we have ways of doing this, the reader is asked to refer to figure 109, in which P is the arm operated by the

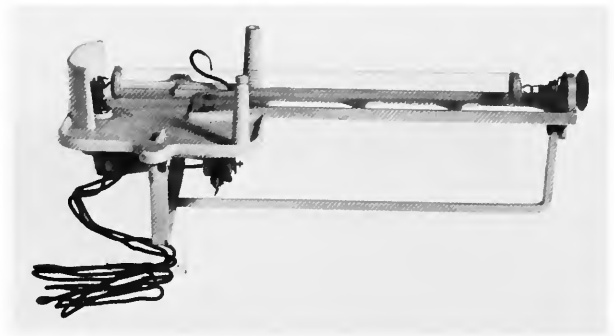

FIGURE 110

MHT 312,799. Hair hygrometer used with Weather Bureau radiosonde. A cylindrical cage of hairs, mounted on the upper surface of a light, white-plastic molding, on the lower side of which is a wound resistor over which a contact is moved by the change in length of the hairs. Marked "WIT." Overall length, 20 cm. Presented in 1944 by the Plaskon Co., Inc., Toledo, Ohio. (Smithsonian photo 61901-D.)

barometer, sweeping over a number of conducting strips in an insulating block. Certain of the strips, numbered 1, 6, 11, etc., in the figure, are wider than the rest. Connected in series between one of the grids of a multi-electrode tube and the frame of the instrument are a fixed resistor R , a resistor H with a contact at c operated by a hygrometer, and a resistance T that varies with temperature.

When the pointer P is not touching any of the contacts, the only path from the grid to the frame is through all the resistors R , H , and T in series. In this condition the total resistance will be a function of the temperature, and so will the audio frequency emitted. When the pointer touches any of the narrower, unnumbered contacts, the total resistance will be R plus the portion of H between a and c . This is a function of the humidity. When it touches strips 11 and 26, the point a is connected directly to the frame, resulting in an upper fixed frequency. When it touches numbers 1, 6, 16, and 21, the point b is connected to the frame, and a lower fixed frequency is produced.

²⁰⁶ R. Bureau, *La Météorol.*, vol. 7 (1931), p. 307.

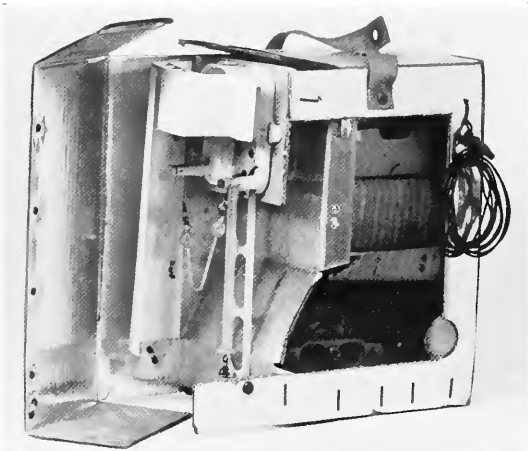

FIGURE 111

MHT 312,798. Radiosonde used by the United States Weather Bureau in 1942, with its foil-covered carton, 22 x 22 x 11 cm, cut away to permit most of the components to be seen. This has the electrolytic thermometer and the hair hygrometer that operates a variable resistor. It is marked "Sonde Track Manufactured in the United States by Washington Institute of Technology U.S.W.B. 1942." Presented in 1944 by the Plaskon Company, Inc., Toledo, Ohio. (Smithsonian photo 61905.)

The thermometer adopted for use with this circuit was, at first, electrolytic, a small V-shaped glass tube filled with a nonfreezing electrolyte and with an electrode at each end. The hygrometer was a bundle or a cylindrical "cage" of hairs operating a contact on a resistance coil, as in specimen MHT 312,799 (figure 110). A very ingenious carton was designed to hold the entire instrument, with flaps that could be tied back to expose the thermometer and hygrometer in their radiation shields. This sort of carton is found on American radiosondes until recent times, and the Museum has many examples, one (MHT 312,798) being partly cut away to show some of the contents (figure 111). An example of the complete instrument (MHT 322,315) is shown in figure 112.

The electrolytic thermometer was later replaced

by a semiconductor with a large temperature coefficient of resistance, known as a "thermistor," which could be made very small (MHT 327,975, figure 113). At a still later date, it was found that these thermometers could be rendered nearly insensitive to radiation by coating them with a special white paint, as in MHT 324,242.

MHT 324,242. Two white-coated thermistors, each sealed in a glass tube 8 cm long. Their wire leads are also partly painted. Transferred from the Weather Bureau in 1964.

While designing their radiosonde the workers at the National Bureau of Standards were attempting to find a satisfactory humidity-sensitive resistor, a problem that has been attacked sporadically since about 1920.²⁰⁷ Various ideas were tried, leading finally to the transparent plastic strip with metallized edges (MHT 327,976) shown, together with MHT 327,975 in figure 113, as mounted for use in the radiosonde.²⁰⁸ The adoption of the electrical hygrometer made it impossible to operate with the simple circuit shown in figure 10.13, and a greatly improved circuit was devised, necessitating the use of a relay, but having only one vacuum tube, a twin triode.²⁰⁹

The Bureau of Standards radiosonde in these and later forms has been immensely successful. The fact that the telemetry depends on change in resistance makes it adaptable to other problems, and as early as 1939 R. Stair applied it to measurement of the ultraviolet radiation in the atmosphere.²¹⁰ The Museum has another experimental radiosonde equipped for photometry

²⁰⁷ See A. Wexler, *Circ. Nat. Bur. Stds.*, no. 586 (1957) for a summary of this work.

²⁰⁸ This was devised in 1942 by John Onderdonk, but with no publication. See D. A. Mathews in *Humidity and Moisture. Measurement and Control in Science and Industry* (New York: Reinhold, 1965-66), vol. 1, p. 220.

²⁰⁹ H. Diamond, W. S. Hinman, F. W. Dunmore, and E. G. Lapham, *J. Res. Nat. Bur. Stds.*, vol. 25 (1940), pp. 327-76.

²¹⁰ *J. Res. Nat. Bur. Stds.*, vol. 22 (1939), pp. 295-300.



FIGURE 112

MHT 322,315. Radiosonde in foil-covered carton, 22 x 11 x 22 cm. Two flaps open to reveal the electrolytic thermometer and a cylindrical array of hairs that operates a variable resistor. This apparatus is mounted on a white plastic molding, and enclosed in a semicylindrical white shield with louvers at the upper end. Batteries and a transmitter (heat-insulated)

and a "baroswitch," occupy the remainder of the carton. Labeled "Sonde-Track Manufactured in the United States by Washington Institute of Technology, Washington, D.C. U.S.W.B. 1942 Serial No. 214024." There are two labels of instructions to the finder. Transferred from the Weather Bureau in 1963. (Smithsonian photo 61905-B.)

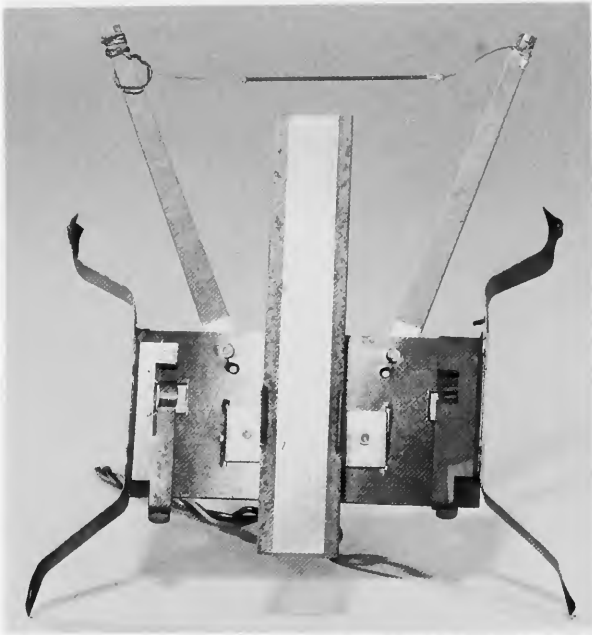

FIGURE 113

Thermistor thermometer (MHT 327,975) and electric hydrometer (MHT 327,976). (Smithsonian photo 61553.)

MHT 327,975. Thermistor, 1.0 mm in diameter and 4.4 cm long. Transferred from the Weather Bureau in 1966.

MHT 327,976. Electrical hygrometer for radiosonde, consisting of a strip of transparent plastic 10.0 x 1.7 cm, metallized on the long edges, and coated with a hygroscopic electrolyte. Transferred from the Weather Bureau in 1966.

(MHT 313,528), the origin of which is not known.

MHT 313,528. Special radiosonde equipped for upper-air photometry, in a balsa-wood box 17 x 22 x 14 cm. This contains a pressure switch (similar to MHT 312,800) and also a second switch with six contacts, operated by an electric motor of the type used by Curtiss and Astin. There is also a 3-tube radio circuit in the box, and outside it are mounted two phototubes with "G 1" etched on the glass envelope of one and "8" on that of the other. Transferred from the National Bureau of Standards in 1950.

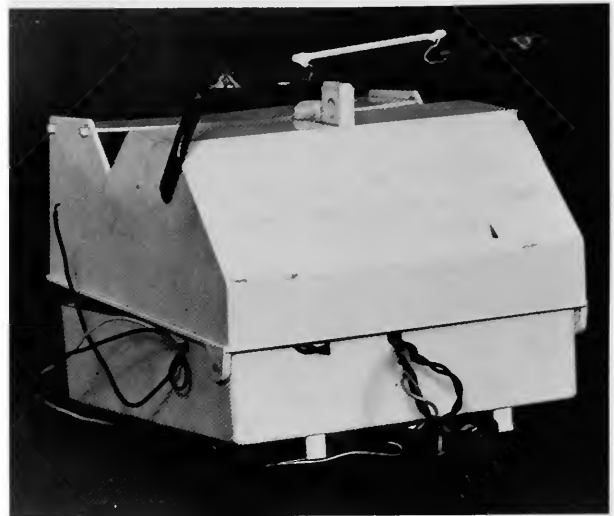

FIGURE 114

MHT 324,240. White plastic box 12 x 11.5 x 9 cm contains a solid-state transmitter and a baro-switch and has brass arms for fastening a thermistor, supplied in a small sealed tube. There is provision for attaching a battery box. The instrument is marked "Radiosonde set AN/AMT 11 B . . . Molded Insulation Co." Transferred from the Weather Bureau in 1964. (Smithsonian photo 61908-C.)

It is unnecessary to go into detail about the various modifications of this instrument, only some of which are represented in the collection. The radio frequency of the signals greatly increased, first to about 400 mc/sec and later to 1680 mc/sec, because of the requirements of radio direction finding. Frequency modulation and, later, pulse modulation were introduced. MHT 317,728 is an example of a radiosonde operating on 1680 mc/sec.

MHT 317,728. Weather Bureau radiosonde of 1960. The parts of this radiosonde are contained in a white cardboard box 20 x 19 x 12 cm, out of which the mounting for the white thermistor thermometer and the electric hygrometer extend. The box is marked "Ray Sonde Bendix Friez Instrument Division Bendix Aviation Corporation." Below the main box is a tube, 5.0 cm in diameter and terminating in a cone and a smaller tube, the whole 15 cm long. This contains a transmitter operating on 1680 mc/sec. Transferred from the Weather Bureau in 1960.

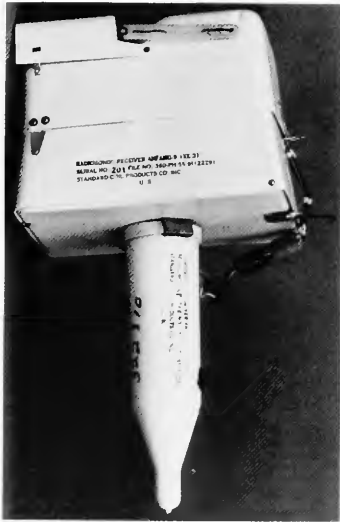

FIGURE 115

MHT 322,310. Radiosonde with a transponder, marked "Radiosonde Receiver AN/AMQ-9 (XE-3) Serial No. 201 File No. 360-PH-55.91 (2229) Standard Coil Products Co. Inc. U.S." on its white plastic case, 20 x 14 x 15 cm. From the top of this project fittings for a thermistor and an electrolytic humidity element, and from the bottom a white plastic tube 5.2 cm in diameter ending in a cone and a smaller tube, the whole 21 cm long, and containing a 1680 mc/sec transmitter. The marks on this are illegible. The main case contains a space for batteries, a clock-driven switch, and a receiver, which receives signals from the ground at 403 mc/sec, pulse-modulated at 75 kc/sec, and adds the audio-frequency pulses from the meteorological instruments. The output of this is used to modulate the 1680 mc/sec transmitter. Transferred from the Weather Bureau in 1963. (Smithsonian photo 61905-C.)

In the late 1950s, molded white plastic cases began to replace the corrugated-cardboard boxes used for two decades, and experiments were also made with solid-state (transistorized) radio circuits, as in MHT 324,240 (figure 114). Still more recently, the principle of the transponder has been adopted for some radiosondes. In this, a pulsed signal is sent out from the ground to the radiosonde, which adds information from the

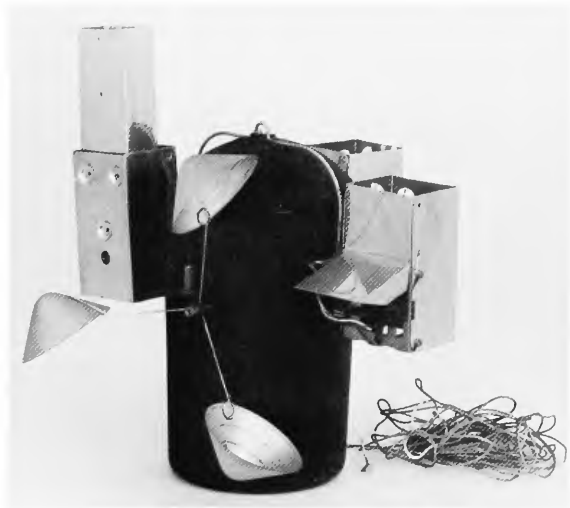

FIGURE 116

MHT 322,313. British Meteorological Office radiosonde, Mark II. The transmitter and batteries are in a black molded-fiber box 12 cm in diameter and 23 cm high, in the bottom of which is molded "Whitely Electrical Radio Co. Ltd. Mansfield Notts England M.O. [monogram] Mark II Met. Ref. N° 2807." The transmitting elements in rectangular aluminum shields project in three directions from the side of the box. In the fourth is a wheel with three conical cups, which revolves in the air-stream to operate the switch that connects the three meteorological transducers in sequence. Transferred from the Weather Bureau in 1963. (Smithsonian photo 61906-B.)

meteorological instruments and transmits back to the ground a modulated signal at a much higher frequency. The Museum has an example (MHT 322,310, figure 115).

Going back to the 1930s, we find that the British, like the Americans, had reviewed the possibilities and decided independently on an audio-frequency-modulated signal,²¹¹ but the solution adopted at the National Physical Laboratory was quite different, especially in two respects: all the meteorological elements were

²¹¹ H. A. Thomas, *Proc. Royal Soc., Sec. A*, vol. 167 (1938), pp. 227-50.

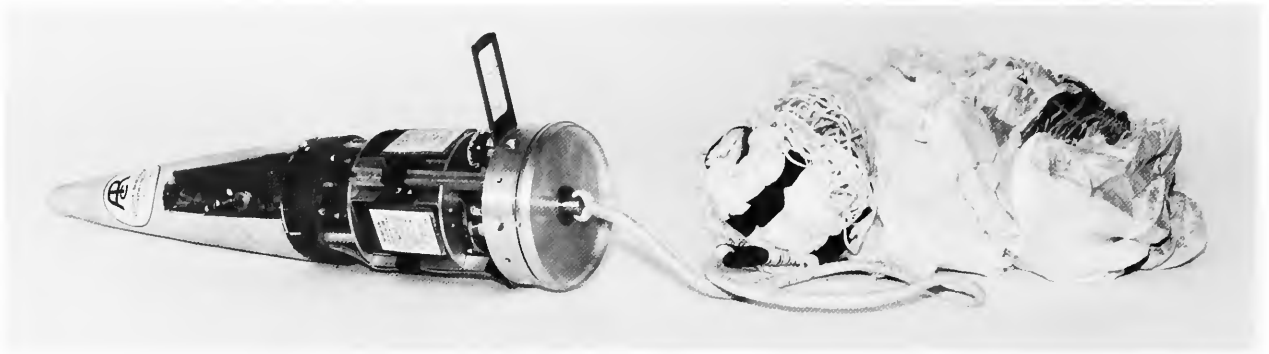

FIGURE 117

MHT 322,051. Instrument package and parachute of the ARCAS "Rocket-Sonde." The instrument package is 10 cm in diameter and 47 cm long. The radiosonde, type AN/DMQ-6, has a receiver, pulse modulator, and transmitter. A switch driven by a small motor connects four sensors, usually small thermistors, into the modulating circuit one after another. The sensors are mounted on a frame which is pushed out laterally when the radiosonde is freed from the nose cone. This catalog number also includes the rocket casing, 11.4 cm in diameter and 230 cm long. Presented in 1963 by the Atlantic Research Corporation, Alexandria, Virginia. (Smithsonian photo 61909-A.)

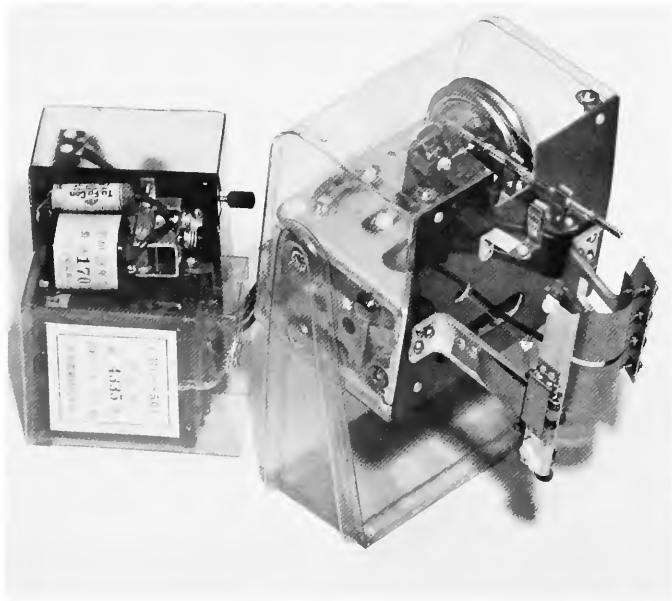

FIGURE 118

MHT 319,826. Japanese code-sending radiosonde, model "CMO-S50L." A raster of contacts is revolved by a small electric motor so as to touch successively points moved by an aneroid, a bimetal, and a "harp" of about 16 hairs. A commutator switches between these, and also makes contact to two tiny mercury thermometers, one of which disconnects the humidity contact at a temperature of -30°C , the other stops the sending of a special signal at -50°C . Otherwise, the indications are interpreted by noting the sequence of the Morse letters N, D, B, T, M, U. The transmitter, which sends out a frequency of 402 mc/sec, is powered by a small storage battery and a vibrator. The instrument is in a white cardboard container 27 x 15 x 11 cm overall, which also acts as a radiation shield. Transferred from the Weather Bureau in 1962. (Smithsonian photo 65996.)

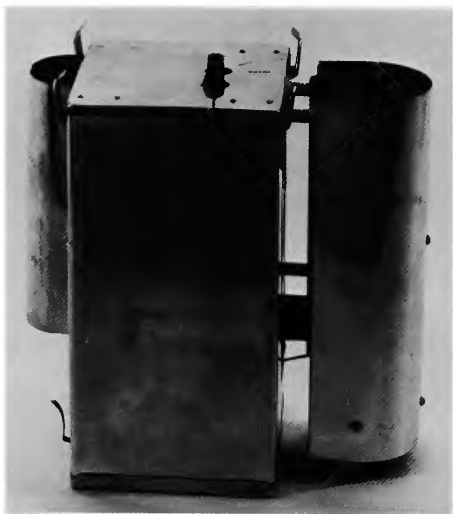

FIGURE 119

MHT 324,241. German code-sending radiosonde, bearing the monogram of Dr. Graw Messgeräte of Nürnberg and the serial number "5821." A light box 10.3 cm square x 20.6 cm high, made of foil-coated fiberboard with sheet-aluminum ends, contains a compartment, foam-insulated, for a battery (missing) and transmitter. A small permanent-magnet motor in the battery compartment rotates a semicylinder which has conducting portions of complicated shape. Arms operated by a barometer (2 aneroid capsules), a thermometer (bimetal), and a hygrometer (a single hair) successively make contacts with the semicylinder. The result is to transmit combinations of two Morse letters for each meteorological element, the whole cycle being repeated eight times a minute. The hair and bimetal have separate shields that project on opposite sides of the instrument. Transferred from the Weather Bureau in 1964. (Smithsonian photo 61906-C.)

measured in terms of audio frequencies, and the variation of inductance, instead of resistance, was used to vary these. By 1940 an improved design had been developed at Kew Observatory by E. G. Dymond and others,²¹² which in its

²¹² Published only in 1947 in *Proc. Phys. Soc. London*, vol. 59, pp. 645-66.

essentials has persisted to the present time with some electrical modifications.

In this radiosonde, the meteorological instruments—an aneroid bellows, a bimetal, and a goldbeater's-skin hygrometer—vary the air gaps in separate inductors with mu-metal cores. These inductors, as well as fixed inductors, are switched into the circuit one after another by a switch operated by a cup wheel. One model of this radiosonde, Mark II, is represented in the Museum by the specimen MHT 322,313 and shown in figure 116.

One more radiosonde in the Museum that works on the variable-audio-frequency principle must be mentioned. This is the "Rocket-Sonde," sent aloft not by a balloon but in the nose of a solid-fuel rocket (MHT 322,051). When the rocket reaches its peak altitude, the nose cone containing the radiosonde is released, and also a parachute, which lets the instrument descend at a reasonable speed. On the way down, it transmits indications of temperature obtained by means of an extremely small thermistor; the direction and range are monitored at the same time, giving the height, as well as the speed and direction of the upper winds. The radiosonde is shown in figure 117, in which the projection on the side is the frame containing up to four thermistors or other sensing elements, which is pushed out by a spring when the nose cone is detached.

Finally, there is a group of radiosondes which, like the Moltchanoff instrument, makes use of a coding device. These are represented in the Museum by a Japanese radiosonde (MHT 319,826, figure 118), which transmits signals entirely in Morse code,²¹³ and a German instrument, MHT 324,241, figure 119, of a type developed about 1950 and widely used for several years thereafter.²¹⁴

²¹³ Central Meteorological Agency, Tokyo, *Guide to Upper Air Observations*, March 1951 (in Japanese). We are indebted to Mr. K. Kobayashi for interpreting the pertinent parts of this document.

²¹⁴ Grateful acknowledgment is given Dr. J. Graw of Nürnberg for detailed information on this radiosonde, which is of his type H 50.

Radiosondes not Referred to in the Text

312,801. Photostatic copy, 70 x 11 cm, of the record of a flight of a radiosonde of the National Bureau of Standards type. Presented in 1944 by the Plaskon Co., Inc., of Toledo, Ohio.

312,802. Radio transmitter of a radiosonde of the National Bureau of Standards type. A plastic case 7 x 9 x 5 cm containing the radio circuit and a vacuum tube, type 1G6GT/G. Presented in 1944 by the Plaskon Co., Inc., of Toledo, Ohio.

313,529. Balsa-wood box containing four radio tubes, small batteries, and some loose wire. Most probably an experimental apparatus. Transferred from the Weather Bureau in 1950.

314,514. Radiosonde designed in Germany about 1935 by Graw.²¹⁵ In general principle similar to that of Duckert (MHT 313,527, figure 101), except that the pressure switch has a series of contacts in an insulating drum. Apart from the bimetal, which is in a plated shield 4 cm in diameter and 10 cm long, the mechanism and circuits are contained in a fiber box 10 cm in diameter and 15 cm long, with spun metal caps. Presented in 1954 by Mr. Kenneth M. Perry of Falls Church, Virginia.

314,677. Variable-audio-frequency radiosonde. The white cardboard carton, 26 x 23 x 12 cm, bears the marks "Northeastern Engineering, Inc." and "U.S.W.B. Serial No. 509401," and has one side cut away to show the arrangement. There is a duct from the lower left to the upper right, in which the thermistor thermometer and the electrolytic hygrometer are held in bronze clips. The pressure switch is at the upper left, the batteries and the transmitter at the lower right. This instrument was found on 13 July 1955, at Redwater, Alberta, and was transferred later in that year from the Weather Bureau.

319,744. National Bureau of Standards type of radiosonde as made in 1940 for the Weather Bureau. Similar to MHT 322,315 (figure 112) except that the hygrometer is a flat "harp" of hairs. Marked "Sonde Track, Manufactured in U.S.A. by Washington Institute of Technology." Complete in its foil-covered carton, 25 x 11 x 21 cm. Presented in 1961 by Mr. Edward L. Reilly of Washington, D.C.

319,824. Part of a British Meteorological Office radiosonde, marked "D698." A somewhat earlier and possibly experimental version of MHT 322,313 (figure 116). Transferred from the Weather Bureau in 1962.

319,829. Part of the meteorograph of a Lang—Reichsamt für Wetterdienst radiosonde, similar to MHT 322,311 (figure 103). Overall dimensions, 14 x 13 x 5.5 cm. Transferred from the Weather Bureau in 1962.

319,831. Mechanical parts of the Blue-Hill radiosonde of 1936, similar to MHT 322,325 (figure 104), but with the aneroid chamber and its contact missing. Mounted on a white-painted board 20 x 10 x 1.2 cm that formed one wall of a box. It is marked "RMF. 84," Transferred from the Weather Bureau in 1962.

322,308. Time-cycle radiosonde marked "Simmonds Chronometer Radiosonde" and "P.B. 121." A bimetal, an aneroid and a hair move contacts along a helix of the Lange type (see MHT 332,325, figure 104). All the parts are mounted on an elaborate black plastic molding 23 x 12 cm, and protected by a thick insulating paper cover on each side. The hair and bimetal are in a shiny aluminum cylinder 6 cm in diameter and 15 cm long. The instrument is accompanied by a calibration chart. Transferred from the Weather Bureau in 1963.

322,312. Another version of the Lang—Reichsamt für Wetterdienst radiosonde. No markings. Transferred from the Weather Bureau in 1963.

322,314. National Bureau of Standards type radiosonde in carton 22 x 11 x 20 cm, covered with smooth paper, now yellowed. Two flaps open to reveal an aluminum tube 6 cm in diameter and 16 cm long, containing a thermistor and an electrolytic hygrometer element. An aneroid barometric switch, a radio transmitter, heat insulation, and batteries occupy the rest of the carton, which is marked "Diamond-Hinman Ray Sonde Mfgd by Julien P. Friez & Sons Division of Bendix Aviation Corporation Baltimore, Maryland U.S.W.B. 1943." Transferred from the Weather Bureau in 1963.

322,316. A radiosonde of the time-cycle type, seriously damaged. It is unmarked, but a tag reads

²¹⁵ See *Zeits. für Geophys.*, vol. 12 (1936), pp. 306–8.

"Longine." It has contacts as in the GALCIT instrument, MHT 319,828 (see page 108) and includes a cork battery box between a radio transmitter and a meteorograph, the latter having rather elaborate radiation shields. Transferred from the Weather Bureau in 1963.

322,320. Friez's attempt to mount a time-cycle radiosonde in the sort of foil-covered carton used for the Diamond-Hinman instrument (see number 322,322 below). The linkage from the bimetal is complicated. There are two "harps" of hair, their deflections being added. The carton is marked "Olland System Ray Sonde. Julien P. Friez & Sons Baltimore." Transferred from the Weather Bureau in 1963.

322,322. A variable-audio-frequency radiosonde marked "Diamond-Hinman Ray Sonde, Mfgd by Julien P. Friez & Sons Division of Bendix Aviation Corporation Baltimore, Maryland." This has the electrolytic thermometer and two "harps" of hair, the changes in length of which are added by a lever. Two concentric radiation shields. Carton 24 x 11 x 21 cm. Transferred in 1963 from the Weather Bureau.

322,323. Radiosonde in two foil-covered cartons, of which the larger, 17 x 10 x 20 cm, contains the batteries, transmitter, and aneroid pressure switch. The smaller, 10 x 10 x 20 cm, contains three concentric aluminum tubes enclosing an electrolytic thermometer and two "harps" of hair arranged so that their changes in length are added and operate a variable

resistor. The smaller carton is labeled "Meteorograph Friez Baltimore U.S. Pat. No. 2,027,367." Transferred from the Weather Bureau in 1963.

324,236. Radiosonde, externally similar to MHT 324,240 (Figure 114), of which it seems to be an earlier model, using a vacuum-tube transmitter. The pressure switch, the contact strip of which is made by using printed-circuit techniques, is similar. The shield for the temperature and humidity elements is missing. Marked "AN/AMT 11 . . . Molded Insulation Co. Serial 1675." The thermistor is supplied in a protective vial. Transferred from the Weather Bureau in 1964.

324,237. A Japanese radiosonde, similar to MHT 319,826 (figure 118), but having two mercury thermometers. The battery is missing, but the instrument seems otherwise complete in its white corrugated carton and is marked "CMO-550L." Serial number 4352. Transferred from the Weather Bureau in 1964.

324,238. Variable-audio-frequency radiosonde. Internally similar to MHT 324,236 above, but the outer case, 15.0 x 12.5 x 12.0 cm, is made of corrugated cardboard with a shiny white surface. It is fitted with an antenna rod 38 cm long and a strap of webbing for the attachment of a battery box, which is missing. There is a calibration sheet for the pressure switch. Presented by the Weather Bureau in 1964.

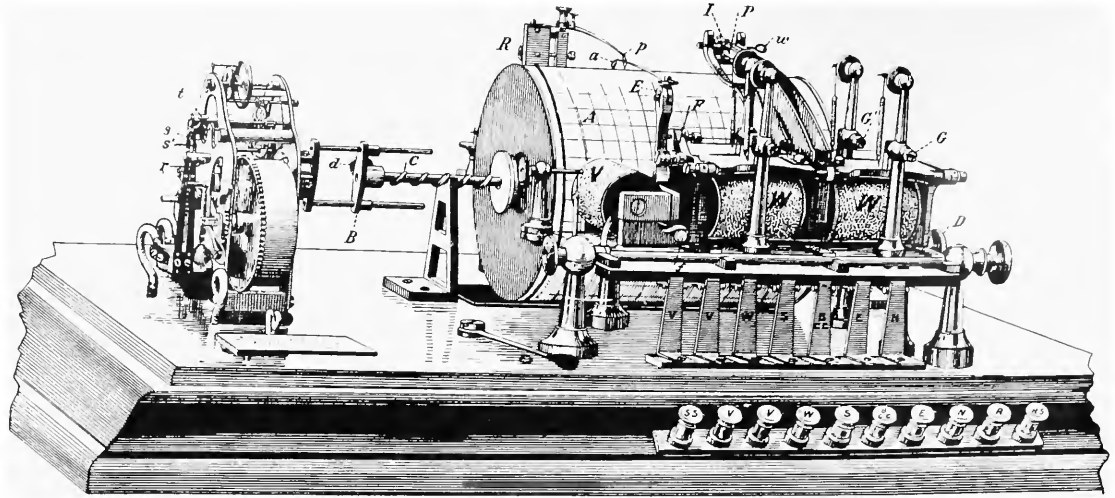

FIGURE 120

Diagram of a station meteorograph or "triple register." (From U.S. Weather Bureau Circular D, 2d ed., 1900, figure 19.)

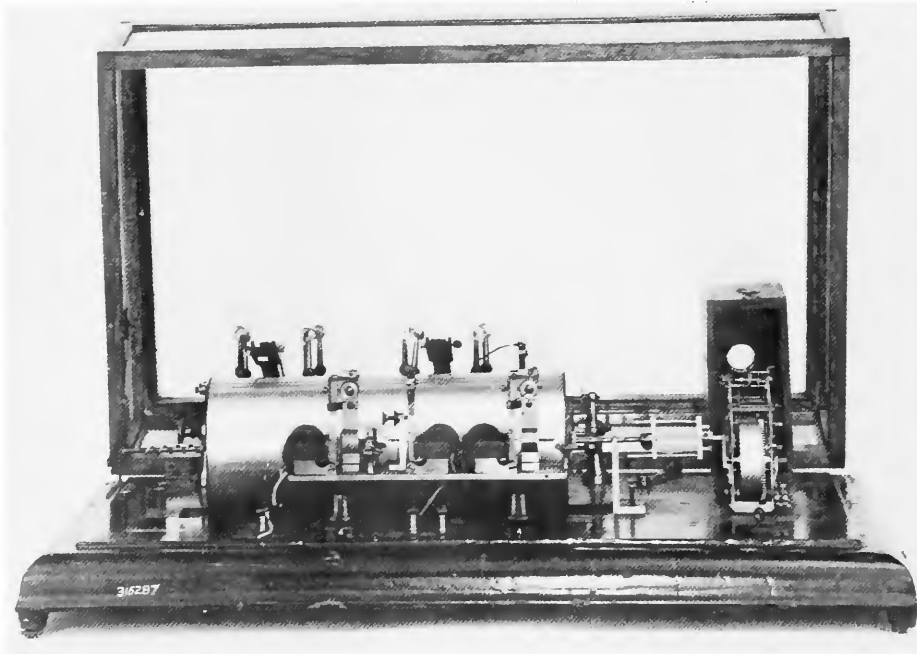

FIGURE 121

MHT 316,287. Station meteorograph similar to the "triple register" (MHT 308,205), but some of the pens and magnets are duplicated, so that it could make two complete sets of records of wind speed and wind direction. The drum is lengthened to 31.5 cm and the cast-iron base measures 74 x 45 cm. There is a hinged cover, glazed on all sides and on the top. A few small parts are missing. The instrument is marked "U.S. Weather Bureau Duplicating Triple Register No. 1." Transferred from the Weather Bureau in 1959. (Smithsonian photo 61904-C.)

Chapter 11

Miscellaneous Meteorological Instruments

In this chapter are collected a small number of instruments that do not fit into the categories dealt with in the earlier chapters of this catalog.

Combination Recording Instruments

The recording instrument is fundamentally a labor-saving device, and American ingenuity in the construction of such things has naturally led to a predilection for meteorological recorders. For half a century after about 1885, many of the stations of the Weather Bureau and the Signal Corps had their sunshine, rainfall, and wind recorded on a "triple register," sometimes called a "quadruple register" because it recorded both the direction and speed of the wind as well as the rainfall and sunshine, all on one large drum.²¹⁶ The Museum has two of these, MHT 308,205 and MHT 314,711 (see also figure 120).

MHT 308,205. A station meteorograph or "triple register" was used by the Weather Bureau for making records of wind, sunshine, and rain. On the heavy cast-iron base, 58 x 45 cm, is a brass label that reads "Julien P. Friez & Sons, Belfort

Observatory, Baltimore, Md., U.S.A." Electromagnets operate pens for wind speed, rainfall and sunshine, and four printing points, with an inking device, record the direction of the wind. The wind direction and the sunshine are recorded once a minute through a contact on the clock that drives the drum, which is advanced axially by a screw of large pitch while it is rotating. The same magnet is used for sunshine and rainfall, and this has an ingenious ratchet and cam that gives a zigzag trace, five steps to the right and then five to the left. There are three small bottles of ink of different colors. Transferred from the Signal Corps in 1923.

MHT 314,711. Station meteorograph or "triple register," similar to MHT 308,205 except that the cast-iron base is 60 x 47 cm, and the brass label reads "U.S. Weather Bureau Triple Register No. 144 Julien P. Friez Baltimore, Md." Transferred from the Weather Bureau in 1955.

The instruments which provided the electrical impulses were the cup anemometer,²¹⁷ the wind vane,²¹⁸ the tipping-bucket rain gauge,²¹⁹ and the Marvin sunshine recorder.²²⁰

²¹⁶ See U.S. Weather Bureau, *Instructions for . . . wind measuring and recording apparatus*, Circular D, Instrument Division, 2nd ed. (1900), p. 44.

²¹⁷ See p. 87 and item MHT 230,001 on p. 86.

²¹⁸ See p. 80, item MHT 315,906.

²¹⁹ See p. 74, item MHT 314,713.

²²⁰ See p. 90, item MHT 308,176.

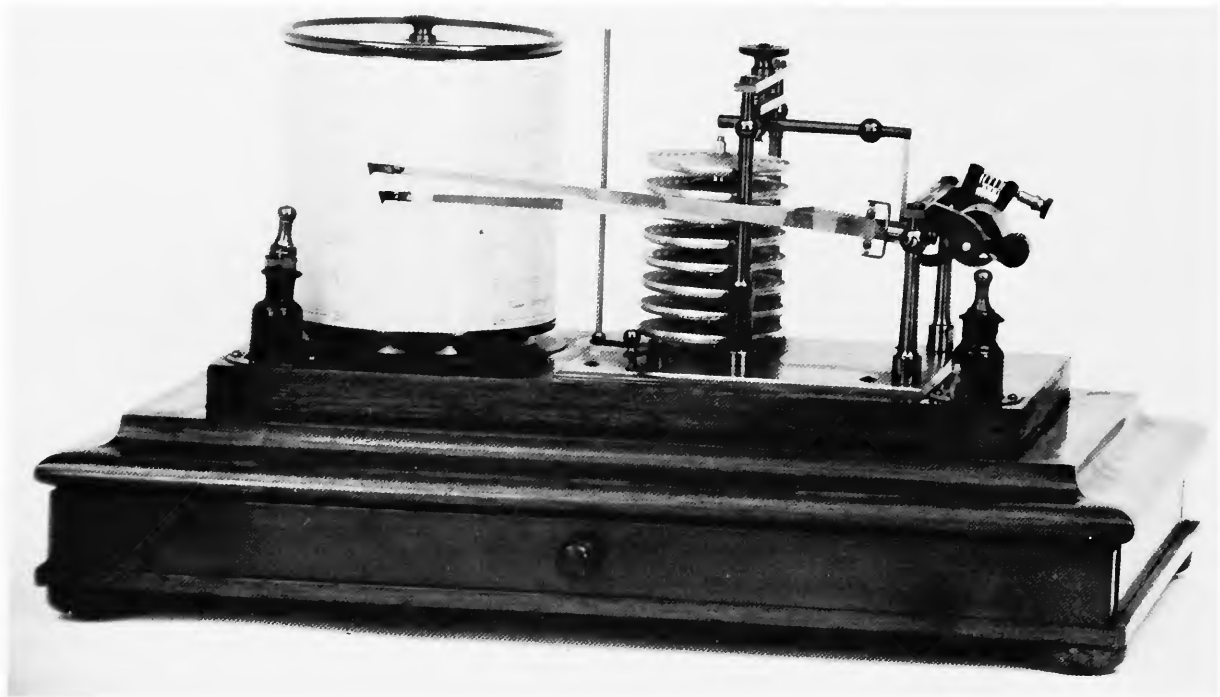

FIGURE 122

MHT 327,633. Thermobarograph. Combined aneroid barograph and bimetallic thermograph recording with two pens on one chart. The barograph has eight aneroid chambers in series. The thermograph has a bimetallic coil of $3\frac{1}{2}$ turns, 2.0 cm in diameter. Inscribed. "Tycos Stormograph Reg.^d U.S. Pat. Off. Short & Mason London Made in Gt. Britain." The clock, which is in the drum, is inscribed "Pat. 3715.02 Made in Germany for Taylor Instrument Companies 7 jewels." Overall dimensions of case, 37 x 21 x 22 cm. Presented in 1966 by Rutgers University. (Smithsonian photo 61906-D.)

The Museum also has the first, and very likely the only example of a station meteorograph that furnished, besides a rainfall and sunshine record, two complete records of wind speed on one drum (MHT 316, 287, figure 121). The purpose of this can only be surmised.

After the Richard firm standardized their light and simple recording instruments, it was quickly realized that more than one element could be recorded directly on one drum. The Museum

specimen is English, with a German clock (MHT 327, 633, figure 122).

Other Instruments, Not Classified

It was noted in chapter 3 that the system of telemetering developed in the 1880s by the firm of Richard could be applied to the distant indication or recording of the readings of any instrument that can move a pointer. The Museum has

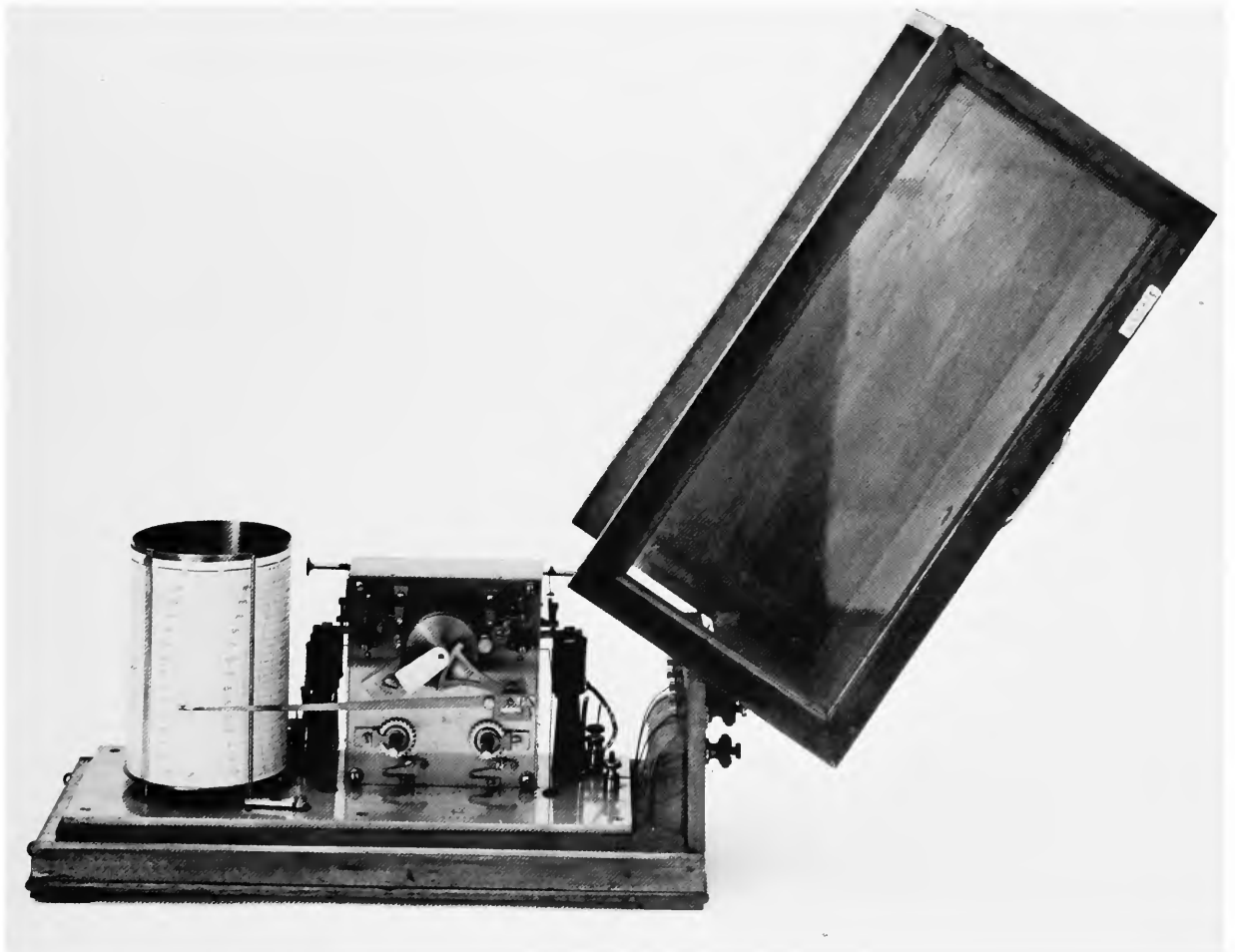

FIGURE 123

MHT 314,537. Receiving station of a telemeter for one of various meteorological elements. On the standard Richard clock drum, 9.2 cm diameter and 13 cm long, there is a 7-day chart graduated from -26 to $+115$, presumably $^{\circ}\text{F}$. The glass-fronted mahogany case, 38 x 17 x 21 cm high, bears a label engraved "Thermomètre enregistreur Anc^{ne} M^{on} Richard Frères, Jules Richard, Succ^r Constructeur Breveté S. G. D. G. 25, Rue Melingue, 25 Paris." The trademark of the firm and the number 44938 are stamped on the brass baseplate. A tag says "Tele Register 44938 from Exposition at Seattle Wash." [1909?] Transferred from the Weather Bureau in 1954. (Smithsonian photo 61910.)

September · 1835

Days of month & week	Thermometer						Barometer					Weather		
	6	9	12	3	6	9	6	9	12	3	6		9	
1 Thurs		62°	30°	30	69	65°	30.	30.10	30	30	30	30	rain & cloudy Clear & dry	
2 Friday		62	73	76		64	30.10	30.10	30.1	30.1	30.1	30.1	30.1	mod' rain
3 Satur	62	62	80	82		72	30.1	30	30.1	30.1	30.	30.	30.	Clear & dry
4 Sun	62	64	81			73	30.6	30	30	30	30	29.9	30	Clear & dry
5 Mon		68	74	76		63	29.8	29.8	29.8	29.8	29.8	29.8	29.8	
6 Tues	54	59	65				30.							
7 Wed	52	66	66	68	62	62	30.0		all day					Clear & dry
8 Thurs	52	60	68	74	71	66	30.1		all day					50
9 Friday	58	66	76	82	80	72	30.10	30	30	30	30	30	30	Clear, Dry & warm
10 Satur	68	72	78	80	76	72	30	30	30	30	30	30	30	cloudy & some rain
11 Sun	70	80	82	84	80	76	30	30	30	30	30	30	30	cloudy & rain
12 Mon	72	80	84	86	84	78	30	30	30	30	30	30	30	clear, dry & warm
13 Tues	73	78	86	88	84	78	30.10	30.10	30.10	30.1	30.1	30.1	30.1	Clear & dry
14 Wed	76	79	86	88	81	70	30.10	30.1	30.1	30.1	30.1	30.1	30.1	Clear & dry till 9 then rain
15 Thurs	70	76	80	83	79	74	30.1	30.10	30.20	30.10	30.10	30.1	30.1	clear & dry till 4 rain
16 Fri	7	76	80	83	7	70	30.1	30.1	30.1	30.10	30	30	30	Clear & dry
17 Sat	74	76	80	83	80	76	30	30	30	30	30	29.9	30	Clear & dry
18 Sun	70	77	82	86	83	76	30	30						Cloudy
19 Mon	70	78	82	87	84	78	30							Clear & dry
20 Tues	70	78	83	88	7	70	30							
21 Wed	70	72	77	79	69	68	30.10	30.10	30.1				30.1	dry till 10
22 Thurs	68	73	76	82	78	76	30.1	30	30	30	30	30	30	heavy till 2 then clear & dry
23 Fri	68	76	84	86	82	77	30.05	30.05	30.0	30	30	30	30	clear, dry
24 Sat	71	77	84	85	75	74	30	30	29.95	29.9	29.9	29.9	29.8	clear till 2 then some rain
25 Sun		61	63	65	62	55		29.95	29.8	30	30	30	30	clear & dry till 10 then rain
26 Mon	55	53	58	63	58	52	30.05	30.05	30.05	30.05	30.05	30.05	30.05	clear, dry & cool then rain at night
27 Tues	57	57	66	70	66	59	29.7	29.6	29.5	29.5	29.5	29.5	29.5	clear & dry
28 Wed	55	63	70	77	66	60	29.53	29.5	29.5	29.5	29.5	29.5	29.5	rain & dry till 10
29 Thurs	56	55	50	55	54	48	29.7	29.7	29.72	29.7	29.80	30	30	heavy till 1 P.M. then clear & dry
30 Friday	57	46	52	58	54	68	30	30.05	30.05	30.05	30	30	30	clear & dry
FOOT		74	53	64	69	62	58	30	30	30	30	30	30	

FIGURE 124

Weather record from Georgetown in 1835.
(Smithsonian photo 61908-B.)

a telerecorder (MHT 314,537, Figure 123) of this kind, which was evidently used to record temperature, but is put here to emphasize the versatility of this apparatus.²²¹ The *modus operandi* of this instrument is substantially the same as that of the telemeter discussed in chapter 3.²²²

The Museum also has three examples of the "storm glass" or "chemical weather glass," which are scarcely serious meteorological instruments, but had a wide popular distribution for many decades. This instrument was simply a sealed glass tube nearly full of a saturated solution of some crystalline substance, with an excess of the solute, so that the quantity of crystals to be seen in the tube is a function of the ambient temperature. Needless to say, its value as an indicator of coming weather is nonexistent.²²³ The three examples, each mounted beside a thermometer, are MHT 322,298; 322,300; 327,559.

MHT 322,298. "Chemical weather glass" and thermometer, mounted in a wooden frame 22 x 8 cm, in front of a paper scale, marked "Standard Barometer" and "Chas. E. Large Brooklyn, N.Y." The chemical weather glass is a tube 17 cm long and 1.2 cm in diameter, filled with an amber-colored liquid containing brownish crystals. The thermometer, 15 cm long and filled with red spirit, has a scale running from -10 to +128 [°F]. On the back of the frame is a printed sheet of instructions. Presented in 1963 by Mr. Silvio A. Bedini, Washington, D.C.

MHT 322,300. "Chemical weather glass" and thermometer. They are similar to MHT 322,298 above in general appearance, except that the thermometer scale is of brass and is

marked "J. A. Pool, Manufacturer, Oswego, N.Y.," and that the "weather glass" is 1.5 cm in diameter. The mahogany frame measures 23 x 8 x 1.8 cm. Presented in 1963 by Mr. Silvio A. Bedini.

MHT 327,559. Glass tube, 22 x 1.5 cm, and a thermometer graduated from -32 to +55° R, mounted side by side on a wooden board 32 x 9 x 1 cm, inscribed "Baroskop." There are 22 inscriptions in Danish near the glass tube, which contains a clear liquid and some brownish crystals. The board is riddled with worm holes. Received in 1966.

The Museum's collections include a shelter for thermometers and other instruments:

MHT 308,179. Instrument shelter of the Signal Corps type, of white-painted wood, 77 x 83 x 52 cm, with louvered sides and back, and a double roof. For some reason it has been encased in glass panels, the louvered front having been removed entirely and replaced by a sheet of glass. There is a metal label reading "Instrument Shelter Type ML 41 Serial [blank] Signal Corps U.S. Army Order No. 110441 Date May 28, 1923." Transferred from the Signal Corps in 1923.

MHT 308,180. Wooden stand for MHT 308,179 above, painted white and 122 cm high. Transferred from the Signal Corps in 1923.

Finally, although it is not an instrument, an honorable place must be found for a 5-year weather record (MHT 317,028) kept by the Reverend James Curley in Georgetown near Washington more than a century and a quarter ago. Figure 124 shows a page of his record book.

MHT 317,028. Meteorological register of weather data. An observation book kept by Rev. James Curley of Georgetown College, Washington, D.C., from 1835 to 1840. He observed the thermometer and barometer at 6, 9, and 12 A.M. and 3, 6, and 9 P.M., and also made remarks on the state of the weather. Presented in 1960 by Georgetown University. (Smithsonian photo 61908-B.)

²²¹ See Richard Frères, *Notice sur les instruments enregistreurs*. . . , 3d ed. (Paris, 1889), pp. 58-9.

²²² See p. 53.

²²³ See Sir Graham Sutton, *Weather*, vol. 20 (1965), pp. 270-271. Some such tubes contain camphor, potassium nitrate, and ammonium chloride, in a mixture of alcohol and water.

Bibliography

- ABBE, CLEVELAND. *Treatise on meteorological apparatus and methods*. U.S. War Department, Annual Report of Chief Signal Officer for 1887, part 2. Washington, 1887.
- KLEINSCHMIDT, E., ed. *Handbuch der meteorologischen Instrumente und ihrer Auswertung*. Berlin: Springer, 1935.
- KURTYKA, JOHN C. *Precipitation measurements study*. State of Illinois, State Water Survey Division, Report of Investigation no. 20. Urbana, Illinois, 1953. This has 193 figures and 1,079 references, but not all the latter have been verified; therefore, this valuable compilation should be checked with care by any researcher.
- LIVINGSTON, GRACE J. *Annotated bibliography of evaporation*. Washington: U.S. Weather Bureau, 1909.
- Manual of radiosonde observations (WBAN)*. (U.S. Department of Commerce, Weather Bureau, Circular P.) 7th ed., June 1957.
- MIDDLETON, W. E. K. *The history of the barometer*. Baltimore: The Johns Hopkins Press, 1964.
- . *A history of the thermometer and its use in meteorology*. Baltimore: The Johns Hopkins Press, 1966.
- . *Meteorological instruments*. Toronto: University of Toronto Press, 1941; 2d ed., 1943; 3d ed., 1953, revised and enlarged by A. F. Spilhaus.
- . *The invention of the meteorological instruments*. Baltimore: The Johns Hopkins Press, 1968.
- NEGRETTI & ZAMBRA. *A treatise on meteorological instruments: explanatory of their scientific principles, method of construction, and practical utility*. London: Negretti & Zambra, 1864.
- PERLAT, A., and PETIT, M. *Mesures en météorologie*. Paris: Gauthier-Villars, 1961.
- Über Radiosonde-Konstruktionen. Denkschrift*. Berlin: International Meteorological Organization, Aerological Commission, 1937. Also a *Nachtrag*, Berlin, 1939.
- WAARD, CORNELIS DE. *L'expérience barométrique, ses antécédents et ses explications. Etude historique*. Thouars Imprimerie Nouvelle, 1936.
- WEXLER, ARNOLD, ed. *Humidity and moisture. Measurement and control in science and industry*. 4 vols. New York: Reinhold, 1965; and London: Chapman & Hall, 1965. See especially volume 1.

QC 876 M986

Museum of History and Technology

(U.S.)

Catalog of meteorological instruments
in the Museum of History and
Technology

60013.

QC 876 M986

Museum of History and Technology

(U.S.)

Catalog of meteorological instruments
in the Museum of History and
Technology

60013.

LIBRARY

National Geographic Society
Washington, D. C.

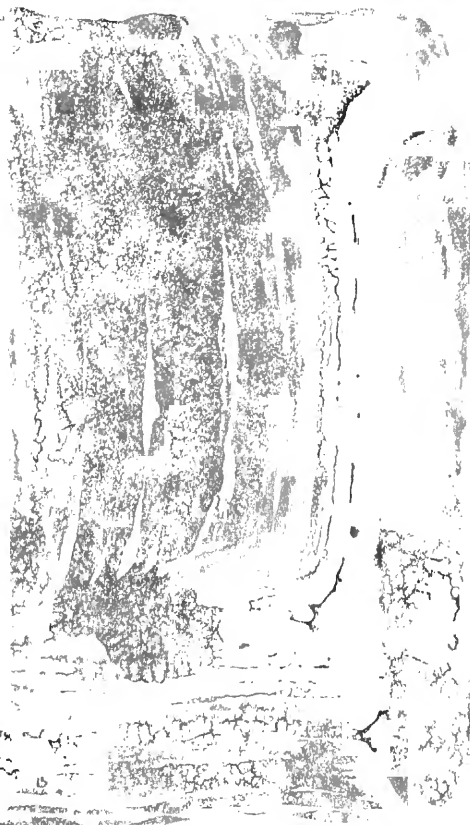

QC 876 M986

Catalog of meteorologic, .C.1 ,lib



0 2000 83205 7