



# **METEOROLOGICAL INSTRUMENTS**

**CATALOGUE No. 877/AC**

**C. F. CASSELLA & CO. LTD**  
Regent House, Britannia Walk  
LONDON, N.1



Catalogue No. 877/AC

# METEOROLOGICAL INSTRUMENTS

C. F. CASSELLA & CO. LTD  
Regent House, Britannia Walk  
LONDON, N.1

Established in London in 1810

Telegrams : "Escutcheon, Rath-London."  
Cables : "ESCUTCHEON, LONDON." Telephone : CLERkenwell 8581 (6 lines).

1963

*Open 7  
Lunch*

*Kew £170  
Fork £96.00*

*01 253 8581  
- six months ?!*

# CASELLA LONDON

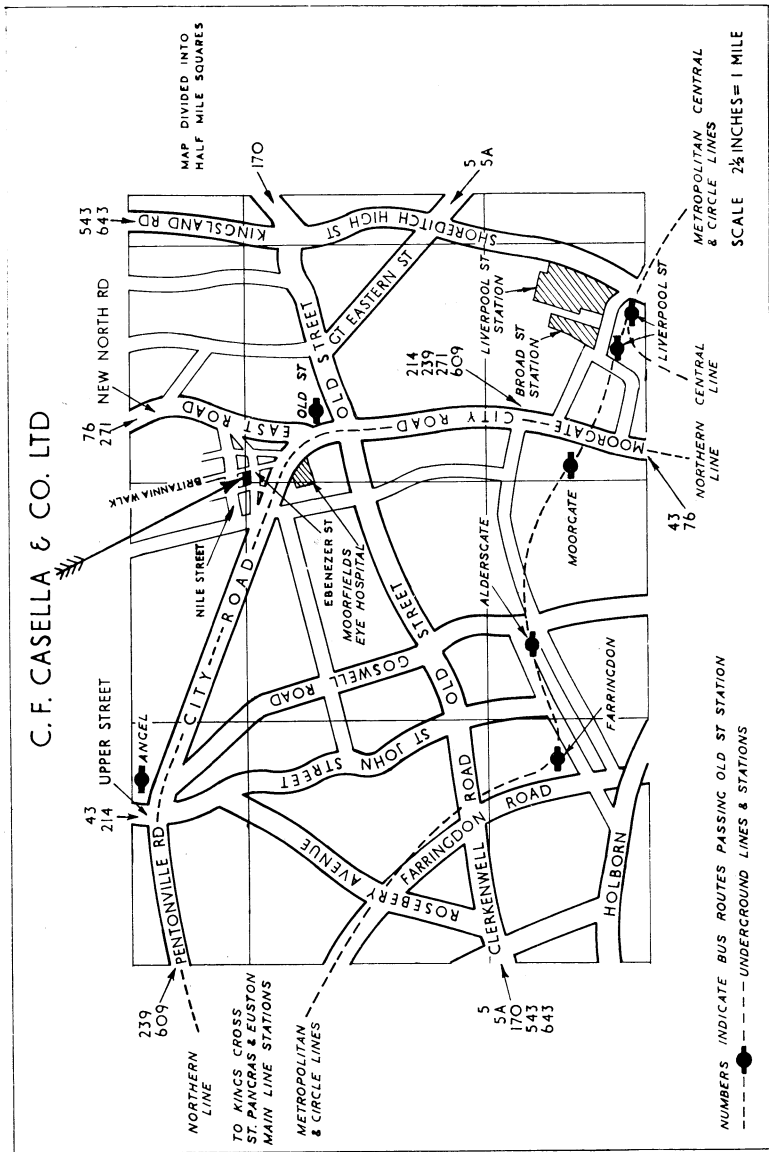



## CONTENTS

GENERAL TERMS OF BUSINESS	...	...	...	4
OTHER CASELLA LITERATURE	...	...	...	5
INTRODUCTION	...	...	...	6 to 8
SECTION 1	Wind Velocity and Direction	...	...	9 to 24
SECTION 2	Atmospheric Pressure	...	...	25 to 40
SECTION 3	Temperature	...	...	41 to 64
SECTION 4	Humidity, Dew-point and Frost-point	...	...	65 to 80
SECTION 5	Precipitation and Evaporation	...	...	81 to 104
SECTION 6	Sunshine, Solar Radiation and Cloud	...	...	105 to 112
Meteorological Charts and Registers	...	...	...	113
Humidity Tables	...	...	...	113
Meteorological Publications	...	...	...	114 & 115
Temperature Conversion Tables	...	...	...	116 & 117
Airflow Conversion Tables	...	...	...	118
GENERAL INDEX	...	...	...	119 & 120



## GENERAL TERMS OF BUSINESS

ON receipt of an inquiry we send, by return of post if possible, a quotation giving as much detailed information as we are able, including our catalogue number, price and delivery date, etc. Where it appears that the inquirer does not possess our latest catalogue either the complete catalogue or the relative portion is sent, whichever seems appropriate. On receipt of an order we send an acknowledgment which shows our reference number for the order ; it helps subsequent correspondence if this number is given to us in all communications.

### United Kingdom Consignments

*Delivery.* Expenses will be charged at cost. No charge will be made for goods delivered by our van in the London area.

*Insurance.* All goods are insured against loss or breakage during transit. A nominal charge is made and we repair or replace without further expense to the customer any loss or damage sustained.

*C.O.D.* In order to save overhead costs we reserve the right to send small value consignments C.O.D.

*Packing Cases.* When chargeable the value of a packing case is shown on our invoice but is not included in the invoice total. It is only charged to the customer if it is not returned to us carriage paid and in good condition within 60 days from date of dispatch.

*New Customers* are requested to send a remittance with order, or give us the usual references.

### Oversea Consignments

We shall be pleased to send Proforma Invoices to enable Import Licences and other formalities to be dealt with. Unless we are instructed to the contrary all consignments are insured at Lloyd's against all risks to the destination made known to us. The insurance costs, the rates of which vary according to the destination and nature of the consignment, are charged to the customer. Where consular invoices, certificates of origin or special legalisation fees are involved, the official costs are charged.

Unless otherwise agreed, arrangements should be made in either London or the consignee's country for payment to be made against receipt of shipping documents by a recognised bank.



## OTHER CASELLA LITERATURE

In addition to the instruments described in this catalogue we also manufacture many instruments for industrial, research and other purposes. Illustrations and descriptions of these will be found in the following publications which we will gladly send to any interested person or organisation.

- Catalogue 808/2** "Instruments for Humidity, Dew Point and Frost Point Measurement," pp. 16
- Catalogue 808/3** "Barometers, Manometers and Pitot Static Tubes," pp 24
- Catalogue 929** "Instruments for Photogrammetry," pp 12
- Catalogue 930** "Instruments for Sampling Airborne Particles including Dust, Bacteria and Spores," pp 36
- Catalogue 934** "Thermometers and Hydrometers," pp 72
- Catalogue 938** "Meteorological Instruments for Schools," pp 28

In addition to the above there are available miscellaneous instruments described by their own separate leaflets. These include the following:—

- Laboratory Grain Mill
- EBC Laboratory Mill
- Temperature and Gravity Compensated Test Barometer
- Mercury Column for Turbine Testing
- Distant Reading Air Meter
- Water Samplers for use in rivers, streams and wells



## Introduction

### Types of Meteorological Stations

**B**ROADLY speaking the variety of purposes for which meteorological observations are required fall into two categories—*synoptic* (for weather forecasting) and *climatological*. Although the observations made at synoptic stations are recorded and preserved for climatological use they would be insufficient for the multifarious needs of climatology. For this reason there is a need for many supplementary stations throughout a country if climatological data is to be of the maximum value for agriculture, industry, medicine, hydrology, etc. These supplementary, or climatological, stations are often maintained voluntarily by private individuals, schools, colleges, local authorities and industrial concerns and the importance of their contributions to many walks of life cannot be too highly praised. In addition to the synoptic and climatological stations in the U.K. there is also the much larger group of *rainfall stations* at which rainfall only is recorded.

### General Requirements of a meteorological station

The *essential* equipment for both synoptic and climatological stations include the following :

Thermometers, wet and dry bulb,	pp 67 to 74
Thermometers, maximum and minimum,	pp 42 to 45
Thermometer screen,	pp 60 to 64
Raingauge,	pp 82 to 89

Other instruments *essential* for a synoptic station and *desirable* for a climatological station are:

Mercurial Barometer,	pp 26 to 34
Barograph,	pp 37 to 40
Anemometer or Anemograph,	pp 13 to 20
Wind Vane,	pp 11 to 12

For synoptic stations and the larger climatological stations the following are *desirable* :

Earth Thermometers,	pp 48 to 51
Grass Minimum Thermometer,	p 47
Hydrograph,	p 77
Nephoscope,	pp 110 to 111
Rainfall Recorder,	pp 90 to 100
Radiation Recorder,	p 109
Sunshine Recorder,	pp 106 to 108
Thermograph,	pp 58 to 59

For recordings to be acceptable to the British Meteorological Office all thermometers and mercurial barometers must be certified by the National Physical Laboratory, and sunshine recorders, rain gauges and rain-gauge measuring jars must be certified by the Meteorological Office.



### Choice of Site and Exposure of Instruments

Since meteorological observations taken at different stations must be comparable and since the results obtained from most instruments vary with their method of instalment and exposure the choice of a site and the exposure of the instruments must be made with considerable care. The ideal site is a plot of level ground, about 30 ft  $\times$  20 ft (9  $\times$  6 m), covered with short grass, and in a position which affords a fair representation of local conditions. It should be away from the influence of trees or buildings and, as far as practicable, should not be sited upon, or close to steep slopes, ridges, cliffs or hollows. Instructions for the installation or erection of instruments vary and will be supplied in printed form with each instrument when it is delivered. The general layout of a station in the northern hemisphere should be as illustrated below.

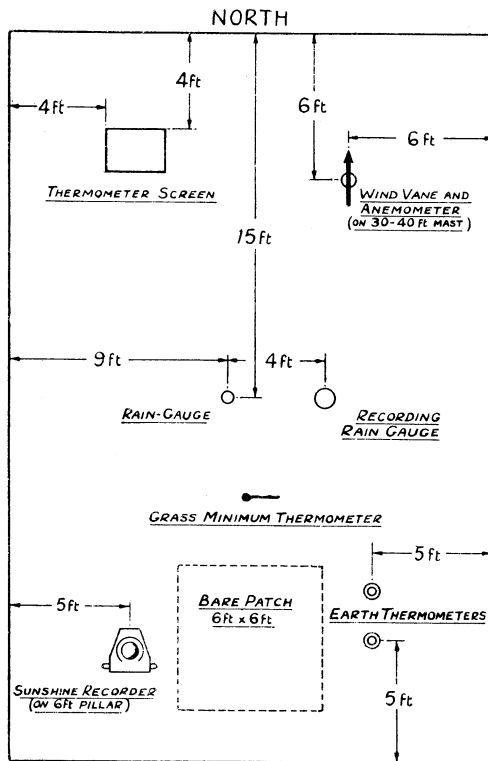

Recommended Layout of a Meteorological Station





## Times of Observations

For synoptic purposes observations throughout the world should be made according to GMT and not local or zone time. They should be made at 0000, 0600, 1200 and 1800 GMT with intermediate observations at 0300, 0900, 1500 and 2100 GMT. As all observations cannot be taken at the exact hour a ten minute tolerance is allowed before or after the synoptic hour. The element which fluctuates most rapidly should be measured exactly at the hour and other observations immediately before or after it.

**Units and Constants** as recommended by the World Meteorological Organisation.

### Units

- (i) **Atmospheric Pressure** in millibars
- (ii) **Temperature** for surface observations in Celsius or Fahrenheit, but for upper air observations in Celsius only
- (iii) **Wind Speed** in knots
- (iv) **Wind Direction** in degrees from north or on the scale 0-36 where 36 is the wind from north and 09 the wind from east
- (v) **Relative Humidity** as per cent
- (vi) **Precipitation** in millimetres or inches

### Constants

The following constants have been adopted for meteorological use

- (i) Absolute temperature of the Ice Point  $T_0 = 273.16^\circ\text{K}$
- (ii) Standard gravity  $= 980.665 \text{ cm/sec}^2$
- (iii) Density of mercury at  $0^\circ\text{C} = 13.5951 \text{ gm/cm}^3$

*This Catalogue supersedes previous editions: the contents are subject to alteration without notice. As thermometer specifications and the design of the instruments are under continual review the illustrations and descriptions should not be taken as being correct in every detail.*



## SECTION I

# WIND VELOCITY AND DIRECTION

### CONTENTS

	Page
Anemometer, Cup Contact ... ..	14
Anemometers, Cup Counter ... ..	13
Anemometer, Cup Generator ... ..	15
Anemometer, Hand ... ..	23
Anemometers, Sensitive 3-Cup ... ..	22
Combined Direction and Velocity Indicators ... ..	16
Digital Read-out Indicators ... ..	14
Dines Pressure Tube Anemograph ... ..	18 to 20
Masts ... ..	17 & 21
Portable Air Meters ... ..	24
Wind Vane ... ..	11 & 12
Wind Vanes, Remote Indicating ... ..	16

### INTRODUCTION

**T**HE instruments described in this section are designed for indicating or recording the wind velocity or direction close to the earth's surface.

The choice of instruments to be made will vary according to the type of station for which they are intended, the accessibility of the site, the range of wind velocity which they are required to cover and whether permanent recordings are required or only readings to be taken at selected hours. Whereas in a network of meteorological stations the synoptic stations will nearly always be equipped with both a wind vane and an anemometer, usually a recording type, the climatological stations may only need to record accurately the wind direction, using the Beaufort scale for velocity estimation. On the other hand, for agricultural research work the type of anemometer normally used by meteorologists may prove unsuitable if measurement of low velocities have to be made close to the ground surface. For this type of work our Sensitive 3-cup Anemometers or Portable Air Meters are recommended.



For the measurement of wind direction or velocity as part of meteorological observations the siting of the instruments is of considerable importance. If the site selected is unduly sheltered measurements will be unreliable since the surrounding objects will create eddies and gusts, interfere with true velocity, and cause oscillation of the wind vane, making it difficult to observe the direction. It is therefore important that an open site is selected where the distance between the instruments and any obstruction is at least 10 times the height of the obstruction. On such a site the internationally accepted standard exposure of wind instruments is 33 ft (10 m) above ground level. The adoption of such a standard exposure is particularly important at airports owing to their international usage. When such an exposure is not possible the instruments should be erected at such a height that their indications are as far as possible unaffected by local obstructions and represent what the wind at 33 ft would be if there were no obstructions in the vicinity. This is usually obtained by placing the instruments at a height exceeding 33 ft by an amount varying with the extent, height and distance of the obstructions.

When erecting the wind vane or anemometer care should be taken that the spindle carrying the rotating vane or anemometer head be truly vertical and that the direction indicating cardinals of the wind vane be correctly orientated to true directions, north, south, east and west. This can be done by reference to the Pole star or by a magnetic compass, making due allowance for the annual change in the deviation of magnetic from due north ; or by reference to the south point which can be found with a good local sundial or by a watch set at "local apparent time." The position the vane takes up with respect to the wind direction should be tested by attaching a long streamer and noting whether its direction agrees with that of the vane. This should be repeated from time to time in case the vane gets a bias one way or another.



## WIND VANE

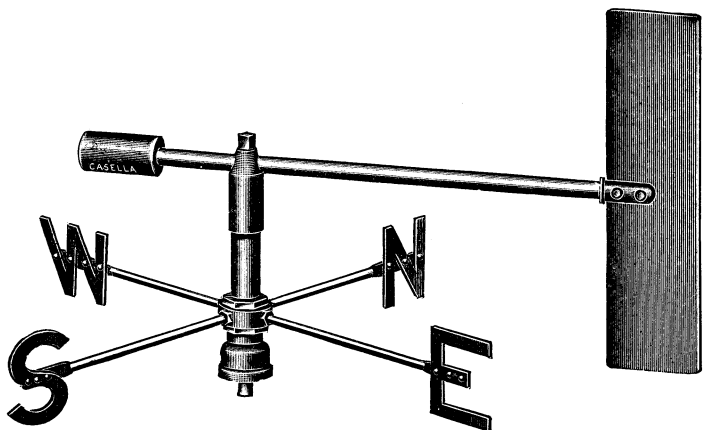

Instruments for indicating the direction from which the wind flows have been used in various forms since Roman and Greek times and today are available in many designs. The Wind Vane described is that which under test meets more than most other patterns the desirable properties for accurate direction indication. It rotates with the minimum friction ; is properly balanced to avoid bias towards any particular direction ; and is designed to produce the maximum torque, for a given change in wind direction, in relation to its moment of inertia. Resonance of the vane to wind fluctuation is avoided as much as possible by damping to make it approximately dead beat. It is manufactured to a British Meteorological Office Specification.

The Vane illustrated above rotates on a ball bearing spindle which is extended below the base. By means of connecting sleeves and direction rods this spindle can be extended into the building on which the vane is mounted and a simple direct-reading dial improvised. The base of the Wind Vane has a 1½ in. BSP socket for screwing to a steel pipe or mast.

- W 1000 **Wind Vane**, British Meteorological Office Pattern, Mk IIB, with cardinal points N S E and W
- W 1002 **Ditto**, but with compass point equivalents in code figures for degrees :—09, 18, 27 and 36 (equivalents to East, South, West and North)  
27 × 18 in    69 × 46 cm    10 lb    4.5 kg



## WIND VANE

### Simple Pattern

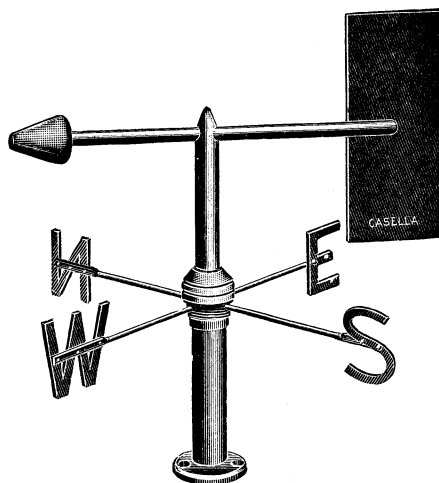

This Vane is recommended to those organisations which do not require the accuracy and precision of the larger pattern offered to a Meteorological Office design and illustrated on page 11. It is essentially an inexpensive instrument which will be of interest to many schools and amateur meteorologists. The balanced vane rotates around a steel point projecting into a phosphor bronze bearing. The direction arms are detachable and the base is drilled for mounting on to a pole or mast. The mast illustrated on page 17 is particularly suitable for carrying this wind vane.

**W 1010 Simple Wind Vane** with direction arms for N S E and W

15 × 15 × 15 in

2 lb

38 × 38 × 38 cm

·907 kg





## CUP CONTACT ANEMOMETER

with digital read-out indicators

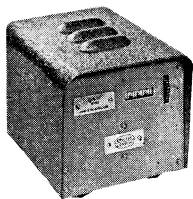

Indicator W 1258

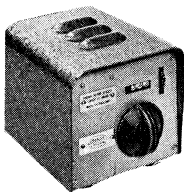

Indicator W 1260

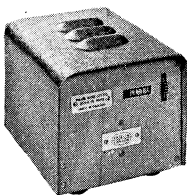

Indicator W 1262

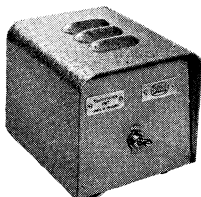

Transformer W 1256

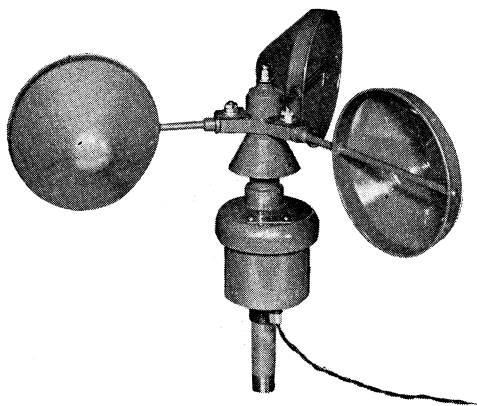

This Anemometer has the same 3 cup system as the Counter Anemometer but the counter wheels are replaced by a switch which is momentarily closed every tenth of a nautical mile, statute mile or kilometre. The closing of this switch operates any of the indicators illustrated, whether used singly or in series from one transformer. Alternatively it operates the audible indicator W 1216/1 without the use of a transformer. It incorporates all the improvements of the cup counter anemometer plus a new long-life micro-switch. Its design ensures a constant contact time irrespective of wind speed and ensures that the switch will never remain in the "ON" position.

Indicators W 1260, W 1262 and W 1264 are set at the observing hour and after ten minutes indicate the average wind speed for that period (a World Meteorological Office Requirement). The indicator W 1258 operates continuously and shows the wind-run. All four indicators can be set up in an office at any reasonable distance from the Anemometer.

- W 1250/1 **Cup Contact Anemometer, nautical miles**
- W 1252/1 **Cup Contact Anemometer, statute miles**
- W 1254/1 **Cup Contact Anemometer, kilometres**
- W 1258 **Run of Wind Indicator**
- W 1260 **Mean Wind Speed Indicator, Manual (10-minute time clock set manually)**
- W 1262 **Mean Wind Speed Indicator, Automatic for 200/250v, 50 cycle A.C. (10-minute average wind speed indicated automatically every hour)**
- W 1264 **Mean Wind Speed Indicator, Automatic for 110v, 60 cycle, A.C.**
- W 1256 **Transformer for use with indicators W 1258 to W 1264**
- W 1212 **2-core Cable, per yard**
- W 1216/1 **Battery Operated Audible Indicator**
- W 1214/1 **Spare Battery for W 1216/1 (4 required for each indicator)**



## CUP GENERATOR ANEMOMETER

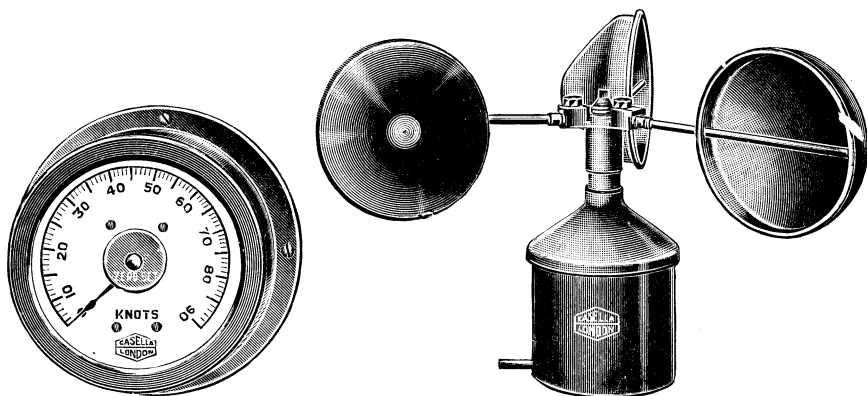

Whereas the Cup Counter and Cup Contact Anemometers are for the measurement of average wind velocities the Cup Generator pattern is designed for obtaining at a distance from the head an instantaneous reading of wind velocity at any given moment. This is done by using the rotation of the cup head to drive a small 12 pole permanent-magnet rotor, the motion of which induces an alternating voltage in the stator windings. This voltage is fed to one or more DC voltmeters, connected in parallel and situated as far from the head as convenient. These incorporate metal rectifiers, temperature correcting elements and have  $4\frac{3}{8}$  in (11 cm) diameter dials and  $6\frac{1}{4}$  in (15.9 cm) diameter flanges for panel or wall mounting. The dials are calibrated in knots, miles per hour or kilometres per hour. The anemometer base is screwed 2 in. BSP for mounting on a mast. From the above description it will be noted that no external source of electricity is required for this instrument.

Although the scale on each indicator commences at zero the characteristics of the rectifier and the anemometer movement itself reduce the effective zero to about 5 kt. In steady winds the instruments should be correct to  $\pm\frac{1}{2}$  kt at speeds from 5 to 20 kt,  $\pm 1$  kt from 20 to 60 kt and  $\pm 1\frac{1}{2}$  kt from 60 to 90 kt. Up to 3 indicators may be connected in parallel from one anemometer without affecting the accuracy, subject to the total resistance of each core of twin cable not exceeding 10 ohms (approximately 550 yd single core cable 0.048 in. diameter).

- W 1300 **Cup Generator Anemometer**, British Meteorological Office Pattern, Mk 1B, complete with one Indicator calibrated 0 to 90 knots and 3 yd of cable
- W 1302 **Ditto**, 0 to 100 miles per hour
- W 1304 **Ditto**, 0 to 160 km per hour
- W 1306 **Extra Indicator** (state calibration required)
- W 1212 **2-Core Cable**, per yard  
Anemometer  $18 \times 11\frac{1}{2}$  in  $45.7 \times 29.2$  cm 14 lb 6.5 kg





## REMOTE INDICATING WIND VANE

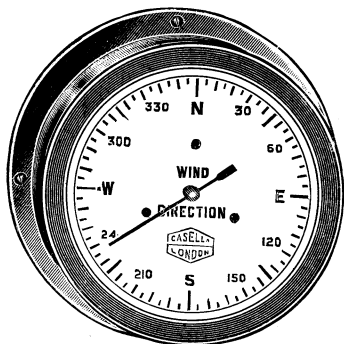

Two types are offered, each incorporating a vane similar to that illustrated on page 11. In the one the movements of the vane are transmitted by the "Desynn" system to the remote dial and in the other "Magslips" are used. The first is less expensive but requires more frequent cleaning and possibly the annual replacement of the Desynn transmitter unit. The second should give many years trouble-free service. Both can operate one or two remote indicating dials.

- W 1100 **Remote Indicating Wind Vane (Dial Pointer Pattern)**, British Meteorological Office Mk IIIA, with one Desynn type indicator dial 0° to 360° and eight Cardinal Points, for use off 12 or 24 v DC supply
- W 1102 **Mains Transformer-Rectifier**, suitable for mains supply and length of cable to be used
- W 1104 **3-Core Cable** per yard
- W 1106 **Extra Desynn type Indicator Dial**
- W 1150 **Remote Indicating Wind Vane (Dial Pointer Pattern)**, with one Magslip operated indicator dial, 0° to 360° and eight Cardinal Points, for use off 200/250 v AC mains, complete with transformer
- W 1152 **5-Core Cable**, per yard
- W 1154 **Extra Magslip type Indicator Dial**

## COMBINED DIRECTION AND VELOCITY INDICATOR

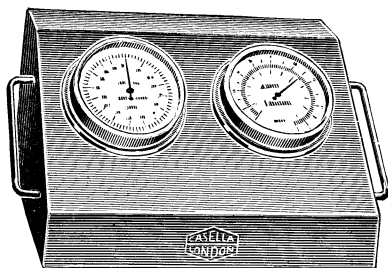

This is a combination of a Cup Generator Anemometer Mk IB (p 15) and a Dial Pointer Pattern Remote Indicating Wind Vane W 1150 above. The anemometer is mounted on the housing which is formed above the vane to hold the "magslip" type of transmitter. One indicator dial is supplied for the direction and one for the velocity. Both are mounted in moulded cases with flanges for panel or wall mounting.

- W 1400 **Remote Indicating Wind Vane W 1150 with Anemometer W 1300**, 0 to 90 knots, complete with transformer
- W 1402 **Ditto**, with Anemometer W 1302, 0 to 100 miles per hour
- W 1404 **Ditto**, with Anemometer W 1304, 0 to 160 kilometres per hour
- W 1152 **5-Core Cable**, per yard
- W 1212 **2-Core Cable**, per yard
- W 1406 **Metal Mounting Cabinet**, for desk use, to take direction and velocity dials, as illustrated above

## SIMPLE MAST

Designed for mounting the simple Wind Vane (p 12) or the three-cup Anemometer (p 13). Standard model offered for 10 ft height. Additional 5 ft sections available. Maximum height 20 ft.

The mast is collapsible and consists of two 5 ft lengths of 1 in gas barrel tubing, three stays, each with strainer, three drilled extension feet and one head piece. The whole unit is supplied packed in a wooden box for delivery by rail or road service. Erection instructions are supplied.

W 1630 **Mast** for 10 ft height

W 1632 **Additional 5 ft** section  
of mast and stays

Net Weight

35 lb      15.874 kg

Gross Weight

47 lb      21.318 kg

Dimensions, packed

62×9×5 in    180×23×13 cm

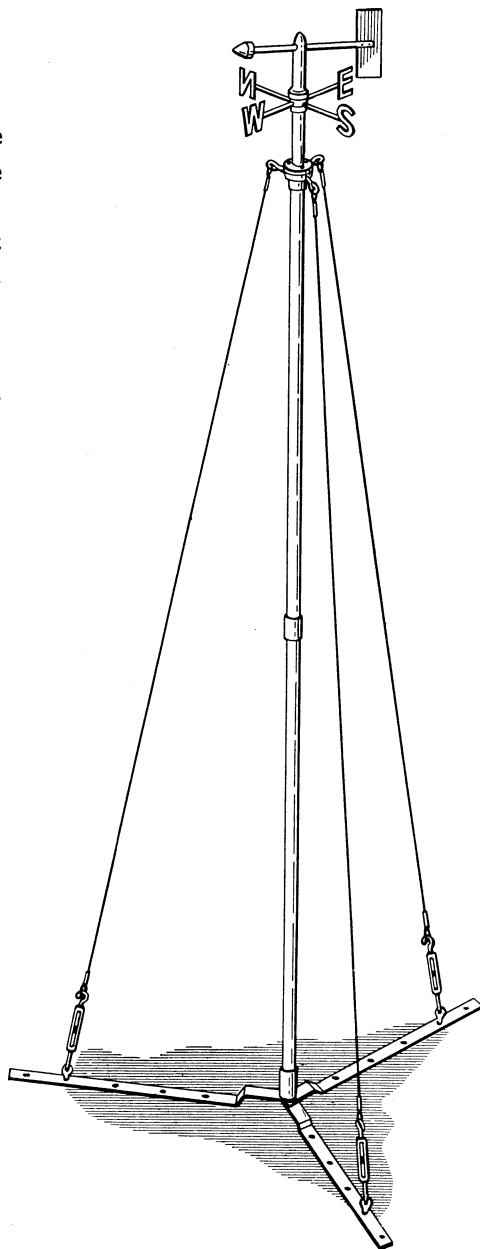

## DINES PRESSURE-TUBE ANEMOGRAPH

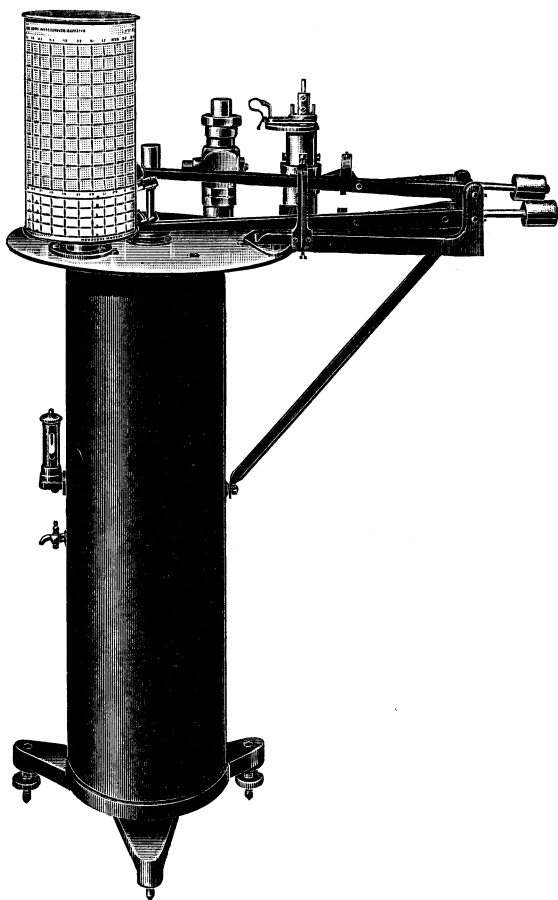

This anemograph records the instantaneous wind speed and direction simultaneously on the same chart. It has been adopted as a standard instrument by the British Meteorological Office and by many observatories and meteorological services throughout the world. It is manufactured in two forms : (1) For direct reading on a recording mechanism situated directly below the head and (2) For remote recording at a considerable distance from the site of installation of the head.



## DINES PRESSURE-TUBE ANEMOGRAPH

(continued)

**Direct Recording Pressure-tube Anemograph Mk II.** The head is a type of pitot tube kept facing into the wind by the vane; it rotates on a ball race at the top of a central supporting tube. The "total head" pressure is transmitted via 1 inch (2.54 cm) diameter tubing to the underside of a copper float situated in the partly filled float chamber of the recording mechanism at the foot of the anemometer mast. The "static" pressure (or suction) is derived from a series of holes drilled into a larger diameter tube surrounding the central supporting tube mentioned above. This static pressure is transmitted via a second length of 1 inch diameter tubing to the space above the water and the float in the float chamber. The pressure difference so created fluctuates with varying wind speeds and causes the float to rise or fall. A rod attached to the top of the float carries a pen which records the float movement on a chart wound round a spring-driven rotating clock. The float is shaped so that, in spite of the non linear equation relating wind velocity to pressure, its rise or fall is made linear. On the chart 0.68 in (17.3 mm) = 10 knots, 0.6 in = 10 miles per hour and 9.5 mm = 10 kilometres per hour.

The wind direction is recorded by connecting the vane to the recorder by means of 5 ft (152 cm) lengths of direction shaft which are joined together, the lower end being connected to the recorder by a universal joint. At the recorder the lower end of the universal joint is connected to a vertical cylinder on which is cut a double helix. Two pens, one above the other, are used and their motion is controlled by cams which fit into the helix. The chart ruling consists of a vertical scale in degrees from north through west, south and east to north. At any one time one of the pens rests on the top or bottom north lines. When the acting pen reaches the north line on which the other pen is resting it immediately returns to the other north line, and further variations in the wind direction are shown by either pen according to whether the wind veers, when the lower pen comes into action, or backs, when the upper pen comes into action.

**Remote Recording Pressure-tube Anemograph.** The head unit of this instrument is similar to that used in the Direct Recording Anemograph except that a transmitting selsyn for wind direction is used instead of the direction shaft. The pressure and static tubes are connected to the float chamber in the same way as those used in the direct recording instrument. The motion of the float rod causes a rotation of a transmitting autosyn. The wind direction and velocity are transmitted to corresponding receiving selsyn and autosyn motors which record on a chart similar to that used on the direct recording anemograph.

The only connection required is electric cable, the size of the conductors depending on the distance between the transmitter and the recorder. This may be up to 1,000 yards (or metres) and more apart. Eight cores are necessary for the installation and it is recommended that two additional cores should be made available for use of telephone lines to signal from either end. Provision is also made for recording velocity directly below the head unit. The recorder for this is not included in the price of the instrument but offered as an extra item.



## DINES PRESSURE-TUBE ANEMOGRAPH

(continued)

- W 1500 **Dines Pressure-Tube Anemograph Mk II**, to record wind velocity up to 90 knots, 110 miles per hour or 180 kilometres per hour, complete with twin-pen direction recorder, velocity recorder, 15 ft (4.57 m) flexible connecting tube, 35 ft (10.67 m) direction shaft, box of accessories and bottle of ink. (*Charts to be selected from items W 1540, W 1542 and W 1544*)
- W 1502 **Metal Dust Cover** for recorder unit, with 2 glass panelled doors and hinged lid
- W 1520 **Remote Recording Pressure-Tube Anemograph**, to record wind velocity up to 90 knots, 110 miles per hour or 180 kilometres per hour, complete with velocity and direction transmitting units, combined velocity and direction receiver with clock and drum, 15 ft (4.57 m) flexible connecting tube, box of accessories and ink. (*Charts to be selected from items W 1540, W 1542 and W 1544*)
- W 1522 **Glazed Metal Cabinet**, to house velocity and direction receiver
- W 1362 **10-Core Cable**, per yard (91.5 cm)
- W 1524 **Recorder Clock and Short Drum**, with base plate for recording wind velocity only directly below head unit. (*Charts to be selected from items W 1546, W 1548 and W 1550*)

### ACCESSORIES

- W 1540 **100 Daily Charts No. 553, Velocity and Direction**, range 0 to 90 knots
- W 1542 **Ditto, Chart No. 423**, range 0 to 110 mph
- W 1544 **Ditto, Chart No. 318R**, range 0 to 180 kph
- W 1546 **100 Daily Charts No. 557, Velocity only**, range 0 to 90 knots
- W 1548 **Ditto, Chart No. 474**, range 0 to 110 mph
- W 1550 **Ditto, Chart No. 473R**, range 0 to 180 kph
- T 6566 **Spare bottle of ink**
- W 1552 **Spare Pen**
- W 1554 **Galvanised Iron Tubing**, 1 in (25.4 mm) bore, in 10 ft (3.05 m) lengths, for pressure and static connections. (*100 ft or 30.5 m necessary for mounting instrument head on 38 ft mast*)
- W 1556 **Spare Recorder Clock and Drum** for velocity and direction
- W 1558 **Spare Recorder Clock and Drum** for velocity only

*In addition to the above we can also supply instruments to record wind velocities of 150 or 220 mph (270 or 360 kph). Quotations for these will be sent against inquiries.*



## ANEMOMETER MASTS

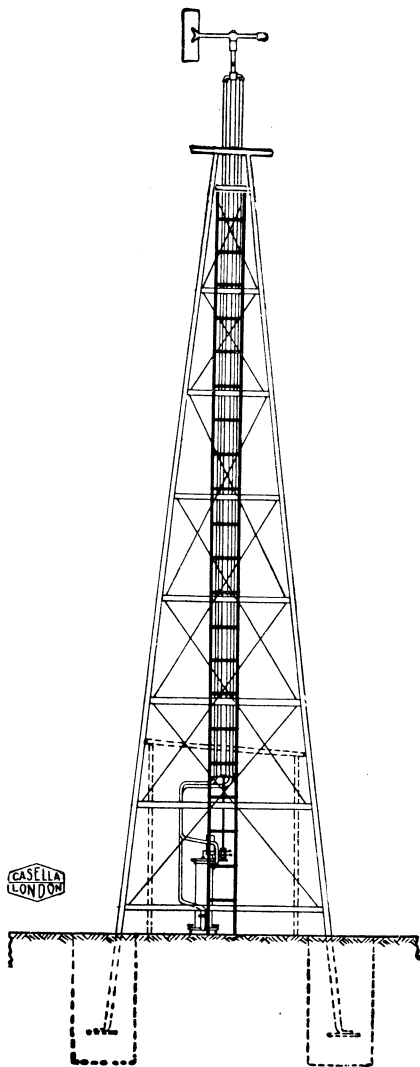

**Galvanised Mild Steel Anemometer Masts**, supplied with angle steel corner posts in 10 ft (3.05 m) lengths, angle steel girts every 5 ft (1.52 m), cast iron feet with fixing plates, angle steel supports for wooden platform, ladder, mast cap screwed 2 in BSP thread to take anemometer with adaptor, complete with full complement of bolts and nuts for assembly on site. Available for the following heights which are measured from ground level to the top of the mast cap.

W 1650	18 ft (5.49 m)	W 1654	28 ft (8.54 m)	W 1658	48 ft (14.64 m)
W 1652	23 ft (7.01 m)	W 1656	38 ft (11.59 m)	W 1660	58 ft (17.69 m)

## SENSITIVE ANEMOMETERS

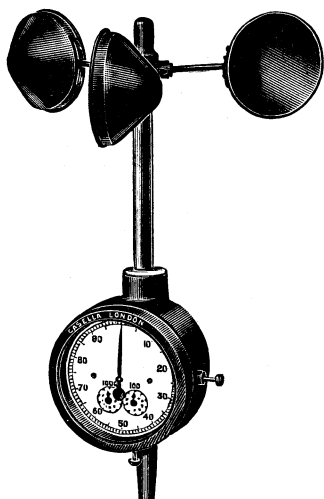

This anemometer is a modified and improved version of the instrument designed originally by Professor P. A. Sheppard in 1940. It combines the advantages of a very low starting speed, slightly in excess of 0.3 feet (0.1 metre) per second, with the ability to withstand exposure to high winds. Its design gives it freedom from overestimation in gusty winds, while its calibration is linear. Each instrument is provided with a calibration chart up to 40 ft/sec or 12.5 m/sec but this limit can be extended if specially requested. It has been shown that the calibration remains constant over a long period of use, damage to the cups, exposure to salt spray, etc., appear to be the only factors to cause a falling off in the curve.

Two models are made, a dial counter pattern and an electric contact pattern. The counter pattern is provided with three rotating pointers, for counting the revolutions of the cups. The main pointer indicates the units up to 100 while the other two indicate hundreds and thousands. By using a stop watch the number of cup revolutions in one or three minutes is recorded; then by reference to the calibration chart the wind speed in feet or metres per second is obtained. In the case of the contact pattern the revolutions of the cups are counted by means of an electromagnetic counter operating at 6 volts and connected to a light contact provided in place of the instrument counting mechanism. Two contacts are made for every three revolutions of the cups, while with the usual counters up to 9,999 counts may be recorded at a maximum rate of 10 per second. This contact pattern is of value where the observer wishes to be remote from the anemometer. The cups of both models are removable and for transport purposes are packed by the side of the main body of the instrument in a carrying case together with the calibration chart.

- T 16100 **Counter pattern**, calibration chart in ft/sec
- T 16104 **Counter pattern**, calibration chart in m/sec
- T 16108 **Contact pattern**, calibration chart in ft/sec
- T 16112 **Contact pattern**, calibration chart in m/sec
- T 16116 **Electromagnetic Counter** for T 16108 or T 16112

Anemometer in case, 12×9×4 in 30×23×10 cm 4½ lb 2 kg

*A more detailed description of this instrument will be found in a separate publication which will be sent on request.*



## HAND ANEMOMETER

This instrument is made to a design approved by the British Meteorological Office. It has three hemispherical beaded metal cups 1.38 in (35 mm) inside diameter, with their centres moving in a circle of 1.26 in (32 mm) radius.

The cup and spider assembly is pinned to a shaft rotating on precision ball bearings. At the lower end of the shaft an annular permanent magnet is secured to a metal flanged ring or keeper. In the air gap thus formed is a light alloy cylinder mounted on jewelled pivots and controlled by a hair spring.

This cylinder carries a pointer which sweeps a near uniform scale visible through a window on the side of the case. The instrument is fitted with a handle and two coned feet to avoid damage to the cups when the anemometer is laid on its side. The fitted carrying case is arranged to clamp the instrument in transit and will not allow it to fall out even if the lid should open. A leather carrying strap is provided.

The instrument will commence to rotate in an air current of 2 knots and may be relied on to give the speed to within  $1\frac{1}{2}$  knots at any point of the scale.

W 1700/1 **Hand Anemometer**, British Meteorological Office approved design, scale range 0 to 60 knots and 0 to 30 metres per second, with carrying case.

W 1700/2 **Hand Anemometer**, as above but scale range 0 to 60 mph

Dimensions and Weights in carrying case:—

$6 \times 6 \times 4\frac{3}{4}$  in     $15 \times 15 \times 12$  cm    2.5 lb    1.15 kg

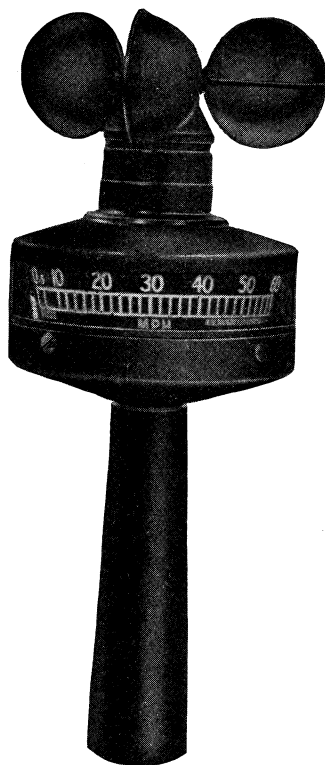





## PORTABLE AIR METERS

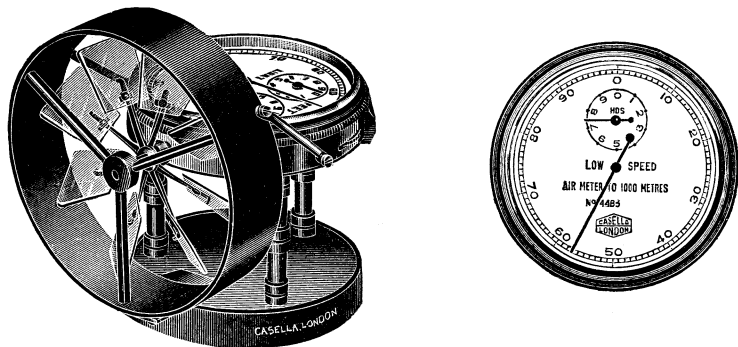

Although not regularly used for meteorological work these air meters can form a useful addition to the range of instruments for measuring low and medium wind velocities, particularly those close to the ground. They are small in size and light in weight, but being delicately made should never be left permanently in position. They should be brought indoors after each observation.

These meters, made for the variety of ranges listed below, register on their dials the number of linear feet of air passing their rotating vanes. By taking a count over a given period with a stop watch, the air speed in feet or metres per minute may be calculated. With the exception of T 16300 and T 16320 all models are fitted with aluminium vanes but for these two instruments mica vanes, which weigh only one-third of a gram are used. Although the minimum velocity registered by these latter two instruments is shown as 50 ft and 16 m per minute respectively, they cannot be considered very accurate below 100 ft and 33 m per minute.

When in use the vanes, which are surrounded by a  $2\frac{3}{8}$  in (7 cm) diameter guard-should face the direction from which the wind blows, with the  $2\frac{3}{8}$  in (6 cm) dial to leeward. In practice this is sometimes done by mounting the instrument on a fixed circular mounting plate graduated in degrees with the 360° mark pointing true north. The instrument is then rotated until the vanes show no tendency to turn one way or the other. It is then rotated through 90° so that its axis is parallel to the wind direction.

**Portable Air Meters**, each with stop-and-start and set-to-zero controls, and provided with rod mounting adaptor and leather case :—

	Minimum velocity per min	Maximum velocity per min	Dials Registering to
T 16300	50 ft	800 ft	1,000 ft
T 16304	150 ft	3,250 ft	100,000 ft
T 16308	300 ft	9,000 ft	10,000,000 ft
T 16320	16 m	250 m	1,000 m
T 16324	50 m	1,000 m	100,000 m
T 16328	100 m	3,000 m	10,000,000 m

In case 4×4×4 in 10×10×10 cm 1 lb 4 oz 0.56 kg



## SECTION 2

# ATMOSPHERIC PRESSURE

### CONTENTS

	Page
Aneroid Barometer, M O patterns ... ..	35
Aneroid Barometer, Pocket size ... ..	36
Barograph, M O Small pattern ... ..	37
Barograph, M O Marine pattern ... ..	39
Barograph, M O Open Scale pattern ... ..	38
Fortin Barometer, Casella patent ... ..	28 to 30
Fortin Barometer, Small size ... ..	31
Kew Pattern Barometers ... ..	26 & 27
Microbarograph ... ..	40
Observatory Barometer ... ..	32 to 34

### INTRODUCTION

**F**OR our mercurial barometers, scales are available for measuring the atmospheric pressure in millibars, millimetres or inches. Until recently the conventions governing the scales of these instruments were very misleading. By international agreement these conventions have now been rationalized and a new series came into use on 1st January, 1955. The history and the final agreements on the scales are the subject of a new British Standard No. 2520. Briefly, all pressure scales have a common zero and now measure pressure directly when the whole barometer is at 0°C, and is subject to standard gravity, 980.665 cm/s<sup>2</sup>. All new barometers supplied by us since 1st January, 1955, comply with BS 2520. We can if desired completely or partially modify existing barometers and we shall be pleased to quote for this work on receipt of the barometer. BS 2520 contains tables necessary for the reduction of readings to the new standard. In all cases the convention to which the barometer conforms is engraved near the scales.

Since millibar, millimetre and inch scales are now correct at 0°C, there is no longer much reason for ordering barometers with two scales, since when a conversion is required this can easily be made by reference to the tables given in BS 2520 which will be supplied with each instrument. We therefore advise customers to order instruments with millibar scales only as strongly recommended in BS 2520.

## KEW PATTERN BAROMETERS

These barometers are the chief types of mercury barometers used in meteorological work, whether on land or sea. Two patterns are made, both to British Meteorological Office Specifications: the Kew Pattern Station Barometer and the Kew Pattern Marine Barometer. They are preferred to Fortin Barometers because owing to their principle of operation only one setting is required when making an observation. This is made possible by contracting the scale to allow for the rise in the cistern level when the barometric pressure falls. Thus the so-called millibars, inches and millimetres are not real units but are shorter by the amount necessary to make the corrections, this depending on the ratio between the bore of the tube and the internal diameter of the cistern. Since it is not necessary to correct the level of the mercury the cisterns are made of stainless steel.

The chief differences between Station and Marine patterns are in the construction of the glass tube and the length of the suspension arm. The central section of the tube in a Marine barometer is made of capillary bore which offers a resistance to the rapid oscillation of the mercury caused by the ship's motion. The longer suspension arm is fitted to prevent the instrument being damaged while swinging.

These barometers cannot be made so portable as can the Fortin type by screwing up the cistern bag until the whole of the cistern and tube are filled with mercury. For this reason they are more difficult to handle in transit by road, rail or sea.

The scale normally recommended is graduated in millibars but if preferred inch or millimetre scales or a combination of any two scales can be provided. A thermometer is fitted to each instrument so that temperature corrections may be made: these thermometers are graduated in degrees Celsius for millibar and millimetre scales and in degrees Fahrenheit for inch scales.

Each instrument is supplied with a gimbal, suspension arm and bracket for wall mounting. *Cases are an optional extra.*



## KEW PATTERN BAROMETERS

(continued)

The scales and combination of scales which can be supplied are as follows :—

Ordinary Range	Long Range	Vernier reading to
870 to 1060 mb	680 to 1060 mb	0.1 mb
25.7 to 31.4 inHg	20 to 31.4 inHg	0.002 inHg
650 to 800 mmHg	510 to 800 mmHg	0.05 mmHg

**Kew Pattern Station Barometers Mk II**, each complete with gimbal, suspension arm and bracket for wall mounting, but without case (see W 2062).

	mb	inHg	mmHg	NPL certificate
Single scale, ordinary range ... ..	W 2000	W 2002	W 2004	W 2006
Single scale, long range	W 2008	W 2010	W 2012	W 2014
	mb & inHg	mb & mmHg	inHg & mmHg	NPL certificate
Double scale, ordinary range ... ..	W 2020	W 2022	W 2024	W 2026
Double scale, long range	W 2028	W 2030	W 2032	W 2034

**Kew Pattern Marine Barometers**, each complete with gimbal, suspension arm and bracket for wall mounting, but without case (see W 2062).

	mb	inHg	mmHg	NPL certificate
Single scale, ordinary range ... ..	W 2050	W 2052	W 2054	W 2006
	mb & inHg	mb & mmHg	inHg & mmHg	NPL certificate
Double scale, ordinary range ... ..	W 2056	W 2058	W 2060	W 2026

W 2062 **Carrying Case**, with rubber packings, lock, key and rope handle, for use with any of the above instruments

W 2064 **Bilham Air Baffle**, for safer transportation. This protects the end of the tube in the cistern and makes it practically impossible for air to enter the tube. It is strongly recommended for instruments being sent long distances.



## PATENT FORTIN BAROMETER

Patented in Great Britain. No. 497025

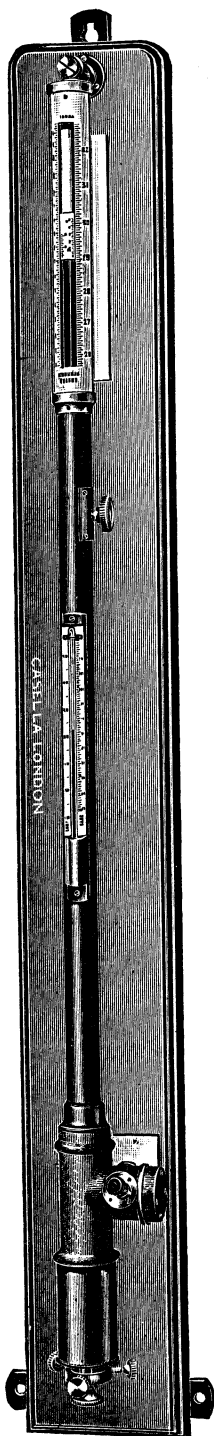

This Barometer, which has now been in use for many years in all parts of the world, has certain marked advantages over the older form of Fortin instrument. These advantages can be briefly described as follows :—

- (1) Greatly increased ease and accuracy of the setting of the fiducial point which is viewed, with its reflected image, through a special optical system. (See illustration on next page).
- (2) The fiducial point is fixed to the metal frame and its height cannot vary.
- (3) An air purifier and a dust trap are provided, hence the mercury in the cistern can always be kept clean.
- (4) The construction ensures that the glass tube is not under strain—therefore the risk of breakage is greatly reduced.

The way in which the above advantages have been achieved is as follows :—

The complete cistern is made of close-grained cast iron. A subsidiary chamber, cast to one side, carries the fiducial point firmly screwed into its top portion. The sides of this chamber have holes in opposite faces, carrying a small eyepiece in the front and a glass disc at the back, these being so positioned that the point and its image, reflected in the mercury surface, appear in the centre of the field of view as shown in the illustration. By this arrangement the point is viewed under good conditions which permit settings to be made and repeated by different observers with an accuracy unattainable with other types of Fortin Barometers.



## PATENT FORTIN BAROMETER

(continued)

Errors which may be caused by poor fitting cistern glasses or excessive tightening of the screws by the users of the more common types of Fortin barometer are avoided by having both the fiducial point and the tube carrying the scale firmly fixed into the cast iron cistern.

Special attention is paid to overcome those troubles which occur when dirt appears on the mercury surface, either in the tube or the cistern. The mercury is trebly distilled and then filtered before use. The tubes are well boiled to drive off air and water vapour, and so ensure good vacua and menisci. Under cap B an air purifier or filter, through which all air entering and leaving the barometer has to pass as the mercury rises and falls, is provided to keep out as much dirt as possible. If, however, after a long period of use the mercury surface in the subsidiary cistern becomes cloudy, it can be cleaned by lowering the usual setting screw A and then raising it again. This allows the mercury to flow into the main cistern and back again into use with its surface clean and sparkling.

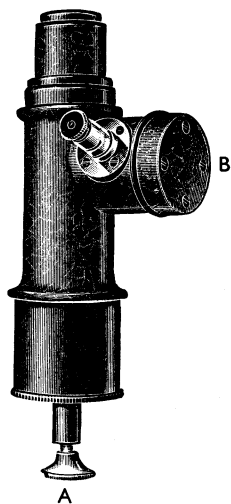

The design of the barometer is such that, although careful handling is necessary, it is sufficiently robust to withstand transit risks with very few breakages. The tube is carefully annealed after working to withstand reasonable shocks or large temperature changes; while since the cistern is of cast iron and the eyepiece and windows are robust, no damage is likely to occur to this part of the instrument.

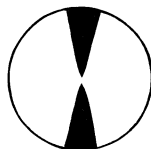

Zero point and its reflected image as seen through the eyepiece



## PATENT FORTIN BAROMETER

(continued)

**Barometer Scales.** Our Patent Fortin Barometer is supplied with either single or double scales in three alternative ranges to enable users at various heights above sea level to choose that which will suit them best. As mentioned in the introduction to this section, single scale instruments divided in millibars are recommended. Details of these scales and ranges as well as the heights above sea level up to which they can be used are as follows :

<b>Ordinary Range</b>	<b>Long Range</b>	<b>Extra Long Range</b>
for use up to 1,500 ft (450 m)	for use up to 3,500 ft (1070 m)	for use up to 8,000 ft (2440 m)
870 to 1070 mb	800 to 1070 mb	680 to 1070 mb
650 to 800 mmHg	600 to 800 mmHg	510 to 800 mmHg
25.6 to 31.6 inHg	23.6 to 31.6 inHg	20 to 31.6 inHg
scales divided in millibars		read to 0.1 mb
scales divided in mmHg		read to 0.05 mmHg
scales divided in inHg		read to 0.002 inHg

National Physical Laboratory Certificate corrections are rounded to the nearest 0.1 mb or corresponding mmHg or inHg, and are accurate to  $\pm 0.20$  mb,  $\pm 0.15$  mmHg or  $\pm 0.006$  inHg

**Patent Fortin Barometers**, fitted with 0.4 in. (10 mm.) bore tube, mounted on polished black board fitted with opal reflectors and metal hanging plates :—

	mb	mmHg	inHg	NPL certificate
Single scale, ordinary range	T 10000	T 10004	T 10008	T 10012
Single scale, long range	T 10016	T 10020	T 10024	T 10028
Single scale, extra long range	T 10032	T 10036	T 10040	T 10044
	mb & mmHg	mb & inHg	mmHg & inHg	NPL certificate
Double scale, ordinary range	T 10048	T 10052	T 10056	T 10060
Double scale, long range	T 10064	T 10068	T 10072	T 10076
Double scale, extra long range	T 10080	T 10084	T 10088	T 10092

Net	16 lb	7.2 kg	44 × 7 × 4 in	112 × 18 × 10 cm
Gross	30 lb	13.6 kg	48 × 9 × 6 in	122 × 23 × 15 cm

T 10096 **Glass and Mahogany Case**, for Patent Fortin Barometer, with glass front and sides, reflectors, lock and key. This forms a good protection against dust

Inside dimensions  $48 \times 5\frac{1}{2} \times 4\frac{1}{2}$  in (120 × 14 × 11.5 cm)



## SMALL SIZE FORTIN BAROMETER

This instrument does not incorporate the improvements of design found in our Patent Fortin Barometer and is constructed in a cheaper manner with a view to making available an inexpensive instrument to those who are not concerned with the higher precision and accuracy obtainable with our other barometer. It is often sold to schools and educational establishments for demonstration purposes. It is fitted with a glass tube of 0.25 in (6.4 mm) bore and is mounted on a polished wood board fitted with reflectors. The scales are as usual divided on the brass frame, silvered and protected by a glass sheath. The usual scales are divided down to 890 mb, 668 mmHg, or 26.3 inHg. The verniers give readings to 0.1 mb, 0.05 mmHg, or 0.002 inHg. Long range barometers can be made to special order to read down to 680 mb, 510 mmHg or 20 inHg.

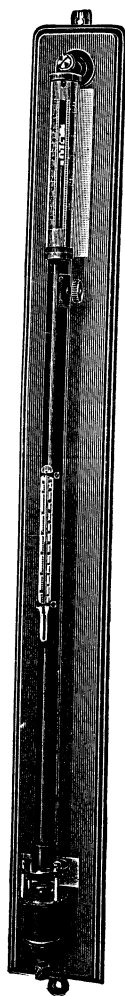

- T 10150 **Single scale, millibars**
- T 10154 **Single scale, mmHg**
- T 10158 **Single scale, inHg**
- T 10162 **NPL Report** on tolerance test of single scale barometer
- T 10166 **Double scale, millibars and mmHg**
- T 10170 **Double scale, millibars and inHg**
- T 10174 **Double scale, mmHg and inHg**
- T 10178 **NPL Report** on tolerance test of double scale barometer
- T 10182 **Glass and polished wood case** for above barometer, with glass front and sides, reflectors, lock and key

Barometer on board	43 × 3½ × 3½ in	108 × 9 × 9 cm	6¼ lb	3 kg
Packed	48 × 6 × 6 in	124 × 15 × 15 cm	17½ lb	7.7 kg



CASELLA  
LONDON

OBSERVATORY

BAROMETER

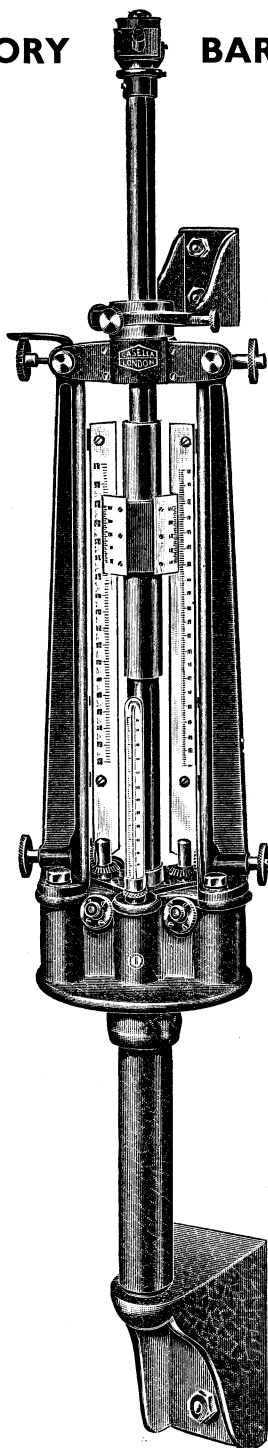

2 ft 10 $\frac{3}{4}$  in  
88.2 cm

3 ft 10 $\frac{1}{4}$  in  
117.4 cm



## OBSERVATORY BAROMETER

(continued)

This instrument is used in first order observatories and meteorological stations in many parts of the world as a very accurate means of measuring atmospheric pressure. It is also used as a reference standard for checking and standardising other types of barometers including those of the Kew and Fortin type. Great attention has been paid to securing accurate readings by the use of points, viewed under magnification, for setting the mercury levels. At the time of writing we ourselves have one of these barometers which has been used for setting our other types of barometers for over 25 years.

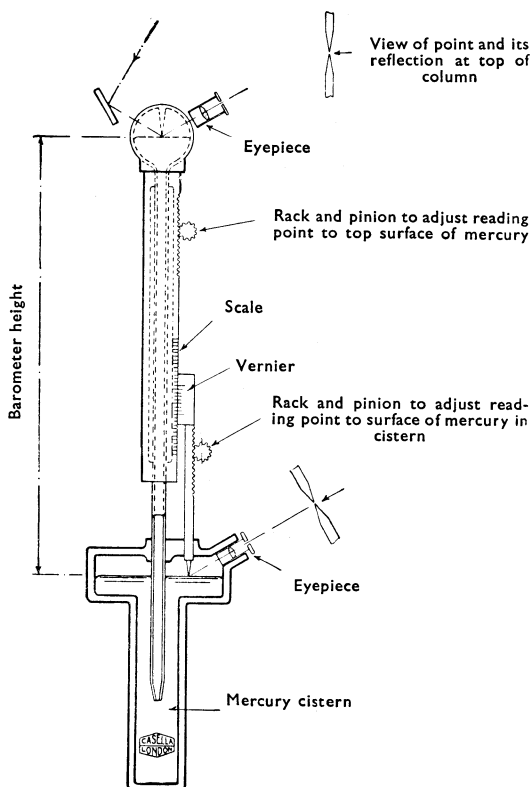



## OBSERVATORY BAROMETER

(continued)

Observation of the fiducial point in this barometer is facilitated by an optical system similar to that in our Patent Fortin Barometer, see page 29. This is applied not only to the cistern level but also to the top of the mercury column. As a result of this and the novel design of the instrument consistent readings of less than 0.05 mb, 0.02 mmHg or 0.001 inHg can be easily made. This compares to the ordinary type of barometer where the readings of different observers can vary by more than 0.2 mb, 0.1 mmHg or 0.004 inHg. The diagrammatic view on the previous page illustrates how this is achieved.

Since the glass tube of a barometer merely serves as a support for the mercury column and does not influence its height we have arranged that the tube, with a point sealed into a chamber at its top, can be moved up and down around the mercury until the point just touches the mercury surface in the chamber. At the same time the space at the top of the chamber is made of such a size that capillary depression becomes of insignificant proportions. Thus the diameter of the chamber is 1 in (25 mm) but since only a small proportion is actually used the diameter of the tube itself is much reduced with a consequent saving in mercury. Furthermore by bringing the mercury to a fixed distance from the top of the chamber the effects of residual air or water vapour are constant.

Since the cistern has to supply the tube with mercury for changes in height and because the end of the glass tube also has to move in and out of it the cistern level alters. Adjustment for this is made by attaching a point to a flat brass bar which carries the scale and which is movable up and down by a screw. The point is thus adjusted to the new level of the mercury in the cistern. In effect the vernier is attached to the tube so that as settings of the top point are made the vernier is moved up and down the scale. Thus the operation of this barometer is the reverse of a Fortin, in that first the point is set to the top of the column and then the adjustment is made for the change in cistern level.

W 2200 **Observatory Barometer**, range 795 to 1065 mb and 595 to 800 mmHg, reading to 0.05 mb and 0.02 mmHg

W 2202 **Ditto**, range 23.4 to 31.5 inHg and 595 to 800 mmHg, reading to 0.001 inHg and 0.02 mmHg

W 2204 **Ditto**, range 795 to 1065 mb and 23.4 to 31.5 inHg, reading to 0.05 mb and 0.001 inHg

W 2206 **NPL Certificate**

$46\frac{1}{4} \times 10 \times 8$  in     $118 \times 25.5 \times 20$  cm    94 lb    43 kg

Packed  $55 \times 25 \times 17$  in     $140 \times 62.5 \times 43$  cm    175 lb    79 kg



# ANEROID BAROMETERS

British Meteorological Office Patterns



Aneroid Barometer Mk II

The two types mentioned are the Mk I and Mk II. The chief difference between them is that the Mk I has a better quality brass case and dial while the dial itself is graduated in inches as well as millibars. For use by our oversea customers we also include similar aneroids with millimetre scales. The movement of both patterns is compensated for temperature with a bimetallic link and is housed in a cylindrical brass case of 4 in. (10 cm) diameter, fitted with a bevelled glass front. A movable index, which can be set independently of the aneroid pointer, is fitted to the glass front for showing change in pressure. An adjusting screw can be operated through a hole in the base of the case.

- W 2250 **Aneroid Barometer**, British Meteorological Office Pattern Mk I, range 880 to 1070 mb and 26.0 to 31.6 inHg, divided to 1 mb and 0.02 inHg, in hinged lid storage case
- W 2252 **Aneroid Barometer** as W 2250, but range 880 to 1070 mb and 650 to 790 mmHg, divided to 1 mb and 0.5 mmHg
- W 2254 **Ditto**, range 26 to 31.6 inHg and 650 to 790 mmHg, divided to 0.02 inHg and 0.5 mmHg
- W 2256 **NPL Certificate**
- W 2258 **Aneroid Barometer**, British Meteorological Office Pattern, Mk II, range 855 to 1055 mb, divided to 1 mb, in hinged lid storage case
- W 2260 **Aneroid Barometer** as W 2258, but range 26 to 31.6 inHg, divided to 0.02 inHg
- W 2262 **Ditto**, range 650 to 790 mmHg, divided to 0.5 mmHg
- W 2264 **NPL Certificate**  
6×6×2½ in 16×16×7 cm 2 lb 6.oz 1.1 kg



## ANEROID BAROMETERS

(continued)

### POCKET SIZE

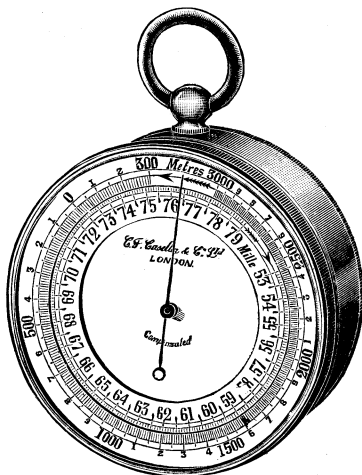

These instruments are similar in design to those described on the previous page except that they are smaller in size and have combined altitude and barometer scales. The altitude scales can be supplied "fixed" or "revolving" according to preference. The movements are mounted in 3 in. (7.5 cm) diameter brass cases and are compensated for temperature changes. They are provided with maroon snap-lid outer cases.

The altitude scale ranges described below are total ranges. Customers are asked to state how many feet or metres below zero are required to be shown on the dial.

Range of Altitude Scale	Fixed Altitude Scale with Barometer Scale :—		Revolving Altitude Scale with Barometer Scale :—	
	inch	millibar	inch	millibar
3,000 ft	W 2300	W 2310	W 2320	W 2330
6,000 ft	W 2302	W 2312	W 2322	W 2332
10,000 ft	W 2304	W 2314	W 2324	W 2334
15,000 ft	W 2306	W 2316	W 2326	W 2336
20,000 ft	W 2308	W 2318	W 2328	W 2338
	millimetre	millibar	millimetre	millibar
1,000 m	W 2350	W 2360	W 2370	W 2380
2,000 m	W 2352	W 2362	W 2372	W 2382
3,000 m	W 2354	W 2364	W 2374	W 2384
5,000 m	W 2356	W 2366	W 2376	W 2386
6,000 m	W 2358	W 2368	W 2378	W 2388

3¼ dia × 1½ in    8.25 dia × 3.8 cm    16 oz    0.4 kg



## BAROGRAPH

British Meteorological Office Small Pattern

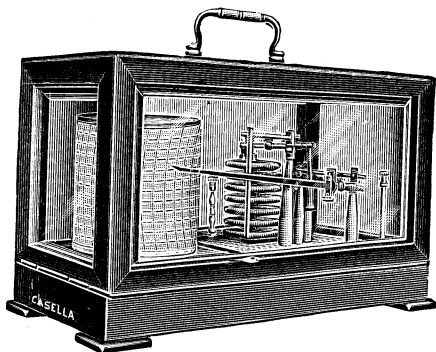

£35

The pressure sensitive unit of this type of recorder consists of a stack of separate evacuated chambers or capsules fitted with internal springs and connected together in series, the lowest one being fixed to a brass plate mounted on the instrument base. The expansion and contraction of this unit with change of atmospheric pressure is transmitted through a lever system to the pen arm spindle and thence to the pen itself which records on a weekly chart covering a range of 950 to 1050 mb with a scale value of 0.75 mm to 1 mb. The instrument is easily adjusted by turning a milled-head screw.

The base and case are both made from good quality, polished hardwood. The top part of the case, or cover, is provided with two windows and is hinged to the base at the left hand end. A handle is fixed to the top.

- W 2450 **Small Barograph**, British Meteorological Office Pattern, range 950 to 1050 mb, complete with 55 charts No. 277, one bottle of ink and instructions
- W 2452 **Ditto**, range 28 to 31 inHg, chart No. 276
- W 2454 **Ditto**, range 710 to 790 mmHg, chart No. 485
- W 2456 **Extra Charts**, 55
- W 2458 **Extra Charts**, 100
- W 2460 **Spare Pen**
- W 2462 **Spare Pen Arm**
- T 6566 **Bottle of Ink**
- T 6574 **Spare Clock**, weekly

12½ × 7½ × 8 in 31.8 × 19 × 20.3 cm 8½ lb 3.85 kg

*An attractive commercial pattern barograph of similar range and sensitivity but manufactured at a lower cost is illustrated and described on page 132 of our Catalogue 808. Details will be sent on request.*



## OPEN SCALE BAROGRAPH

British Meteorological Office Pattern

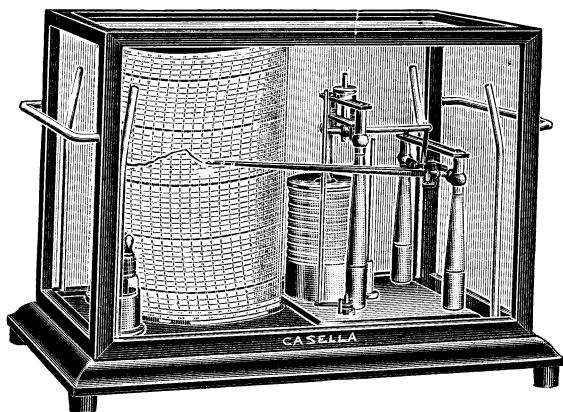

The aneroid unit of this barograph is of the bellows type with an internal spring. The magnifying lever system makes the pen arm move 1.8 mm for a change in pressure of 1 mb. The chart has a range of 950 to 1050 mb or equivalents in inHg and mmHg. Thus the instrument has such a high degree of sensitivity that the movement of the pen is plainly visible during storms. The clock and movement are mounted on a stout metal base. A glass cover with a metal frame is provided to protect the movement and keep out dust.

W 2500 **Open Scale Barograph**, British Meteorological Office Pattern, range 950 to 1050 mb, weekly clock, complete with 55 charts, ink and instructions

W 2502 **Ditto**, range 28 to 31 inHg

W 2504 **Ditto**, range 710 to 790 mmHg

W 2506 **Extra Charts**, 55

W 2508 **Extra Charts**, 100

W 2510 **Spare Pen**

W 2512 **Spare Pen Arm**

T 6566 **Bottle of Ink**

W 2514 **Spare Clock**, weekly

$14\frac{1}{2} \times 10\frac{1}{2} \times 9$  in  $37 \times 26.5 \times 22.5$  cm  $18\frac{1}{2}$  lb 8.4 kg



## BAROGRAPH

British Meteorological Office Marine Pattern

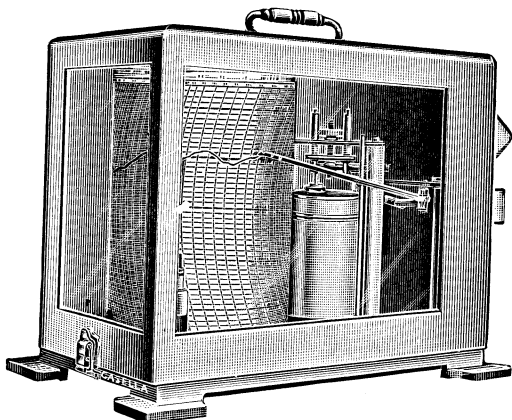

The use of ordinary barographs at sea is unsatisfactory due to the widening of the ink trace as a result of the vibration of the ship's engines, the movement of the ship caused by sea conditions and transient pressure changes caused by gusts of wind. These effects are largely overcome by immersing the aneroid bellows of an 'Open Scale' barograph (p 38) in a brass cylinder filled with a silicone fluid type of oil and by mounting the barograph on a specially designed anti-vibration mounting. The immersion of the bellows in oil reduces the speed of response to true changes in pressure, the lag being dependent on the viscosity of the oil which itself varies with temperature. In practice the oil selected results in a lag coefficient of 100 sec at 30°F, 70 sec at 70°F and 40 sec at 110°F. As the bellows expand the oil is forced through a hole surrounding the rod attached to the top of the bellows into a safety chamber from whence it returns as the bellows contract. In all other respects the instrument movement is similar to that of the Open Scale Barograph already described. The anti-vibration mounting consists of a metal tray on which the barograph is placed; the tray being suspended from fixed brackets by elastic cords.

- W 2550 **Marine Pattern Barograph**, British Meteorological Office pattern, range 950 to 1050 mb, complete with 55 weekly charts, ink and instructions
- W 2552 **Ditto**, range 28 to 31 inHg
- W 2554 **Ditto**, range 710 to 790 mmHg
- W 2506 **Extra Charts**, 55
- W 2508 **Extra Charts**, 100
- W 2510 **Spare Pen**
- W 2512 **Spare Pen Arm**
- T 6566 **Bottle of Ink**
- W 2514 **Spare Clock**, weekly
- W 2560 **Anti-vibration Mounting Unit**  
14½ × 10½ × 9 in 37 × 26.5 × 22.5 cm 19 lb 8.6 kg





## MICROBAROGRAPH

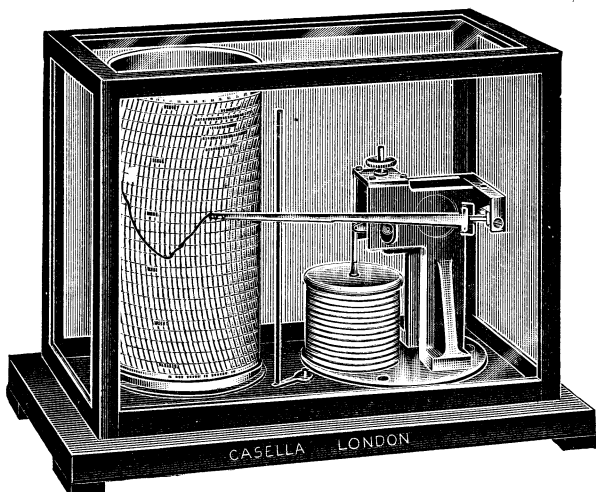

This instrument is the "commercial" equivalent of the Open Scale Barograph (p 38), but with the more restricted range 960 to 1040 mb or equivalents in inHg or mmHg. It employs a similar aneroid unit and a magnifying lever system which makes the pen move 2 mm for a change in pressure of 1 mb. It is more compact than the Open Scale Barograph and is so designed that it can be offered at a lower price without losing in any way its accuracy of performance.

When one of these instruments is to be used at a height appreciably above sea level it is important that we are given this information so that the instrument can be adjusted during calibration to ensure that the pen comes into action at the correct pressure corrected to "mean sea level" at the required height.

- W 2600 **Microbarograph**, range 960 to 1040 mb, complete with 55 daily charts No. 498, ink and instructions
- W 2602 **Ditto**, with weekly charts No. 554
- W 2604 **Ditto**, range 28.5 to 31 inHg, with daily charts No. 558
- W 2606 **Ditto**, with weekly charts No. 559
- W 2608 **Ditto**, range 720 to 780 mmHg, with daily charts No. 560
- W 2610 **Ditto**, with weekly charts No. 561
- W 2612 **Extra Charts**, 55
- W 2614 **Extra Charts**, 100
- W 2616 **Spare Pen**
- W 2618 **Spare Pen Arm**
- T 6566 **Bottle of Ink**
- W 2620 **Spare Clock**, weekly
- W 2622 **Ditto**, daily
- W 2624 **Pick-up-Attachment** for instrument to be used at a height over 1500 ft (450 m) above sea level

12½ × 7½ × 9 in 32 × 19 × 23 cm 10¾ lb 4.8 kg



## SECTION 3

# TEMPERATURE

## CONTENTS

	Page		Page
Canvas Bucket for Sea Water ...	53	Thermometer	
Case, Air Temperature Thermometer ...	53	Earth, Angle Pattern ...	49
Cases, Sea Temperature Thermometer ...	53	Earth, Insulated Pattern ...	50
Screen		Earth, Sheath Pattern ...	48
Bilham ...	60	Earth, Six's Pattern ...	51
Large Size ...	61	Fronde ...	54
Marine ...	61	Grass Minimum ...	47
Stevenson ...	62 & 63	Inspectors' ...	49 & 54
Wall ...	64	Maximum ...	42 & 43
Simple Meteorological Outfit ...	64	Minimum ...	44 & 45
Thermograph ...	58 & 59	Ordinary ...	46
Thermometer		Plant Climate ...	52
Deep-Sea ...	51	Recording ...	58 & 59
		Six's ...	56 & 57
		Terrestrial Radiation ...	47
		Wall ...	55

## INTRODUCTION

FOR meteorological purposes temperature measurements fall into three categories:—air, sea and earth temperature. In this section thermometers, graduated in Fahrenheit or Celsius, will be found to meet each of the three requirements. Wherever applicable they are made to meet the requirements of the British Meteorological Office and to British Standard Specifications. In addition there is included a full range of thermometer screens designed to protect air thermometers from errors caused by radiation effects and to provide, as far as possible, uniform temperature enclosures of the same temperature as the air outside. The choice of screen will vary with the types of thermometers or recorders to be installed. The screen to be used on land should be erected on an open site separated from any near objects such as trees, buildings, etc., by a distance of at least twice their height. The ground surface should be preferably short mown grass and the screen should be mounted on a stand with its base 3 ft 6 in. (106 cm) above the ground level. It should be installed north of the raingauge (in the northern hemisphere), not nearer to it than 10 ft (3 m) and the opening side should face true north so that the sun will not shine on the thermometers while readings are being taken.



## MAXIMUM THERMOMETERS

Maximum thermometers for meteorological observations are of the mercury-in-glass type with a constriction in the bore of the tube below the lowest graduation of the scale. This constriction allows the mercury to be forced through with rising temperatures but prevents it being drawn back with falling temperatures, provided the angle of deviation from the horizontal is not greater than about  $10^\circ$  with the bulb downwards. In practice it is recommended that the thermometer be mounted at an angle of about  $5^\circ$  with the bulb lower than the other end. After a reading has been taken the thermometer can be reset by swinging it steadily downwards in a semi-circular arc, having first ensured that the mercury column is resting on the constriction. This should force the mercury past the constriction to a point within  $0.4^\circ\text{F}$  ( $0.25^\circ\text{C}$ ) of the dry bulb temperature. For each of the three patterns listed normal glass is used for the bulb and lead glass for the stem. Each thermometer is divided on the stem and the figures appear upright when the thermometers are placed horizontal with the bulb on the left.



**Maximum Thermometer, Sheathed Pattern**, made to the requirements of the British Meteorological Office and to BS 692 : 1957. The thermometer stem is fused to an outer glass sheath which is completely sealed so that no condensation of moisture can take place on the thermometer scale.

Length  $13\frac{1}{2} \times \frac{1}{2}$  in  $34 \times 1.3$  cm Weight  $2\frac{1}{2}$  oz 70 grams

	Schedule Mark	Range	Divided to
W 3000	Max. 1/F	+15° to +145°F	1°
W 3002	Max. 2/F	0° to +130°F	1°
W 3004	Max. 3/F	-20° to +110°F	1°
W 3006	Max. 4/F	-40° to + 90°F	1°
W 3010	Max. 1/C	-10° to + 65°C	0.5°
W 3012	Max. 2/C	-20° to + 55°C	0.5°
W 3014	Max. 3/C	-30° to + 45°C	0.5°
W 3016	Max. 4/C	-40° to + 35°C	0.5°

**NPL Certificates** will be supplied for these thermometers if specially requested. For details see current price list.



## MAXIMUM THERMOMETERS

(continued)

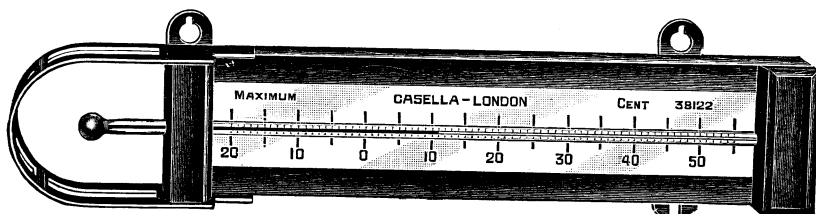

**Maximum Thermometer**, divided on solid stem and indelibly figured on a laminated plastic scale which has proved itself impervious to frosts and all effects of weather. The thermometer and scale are mounted on a polished mahogany frame fitted with brass hanging plates.

Fahrenheit Scale			Celsius Scale		
	Range	Divided to		Range	Divided to
W 3050	+15° to +145°	1°	W 3060	-10° to +65°	0.5°
W 3052	0° to +130°	1°	W 3062	-20° to +55°	0.5°
W 3054	-20° to +110°	1°	W 3064	-30° to +45°	0.5°
W 3056	-40° to +90°	1°	W 3066	-40° to +35°	0.5°

$13\frac{1}{2} \times 3\frac{1}{2} \times 1$  in    $34 \times 9 \times 2.5$  cm   12 oz   340 grams



**Maximum Thermometer**, divided on solid stem, indelibly figured and mounted on strong laminated plastic scale drilled with holes for mounting in screen.

Fahrenheit Scale			Celsius Scale		
	Range	Divided to		Range	Divided to
W 3100	+15° to +145°	1°	W 3110	-10° to +65°	0.5°
W 3102	0° to +130°	1°	W 3112	-20° to +55°	0.5°
W 3104	-20° to +110°	1°	W 3114	-30° to +45°	0.5°
W 3106	-40° to +90°	1°	W 3116	-40° to +35°	0.5°

$11\frac{1}{4} \times 1\frac{3}{8} \times \frac{5}{8}$  in    $28.5 \times 3.5 \times 1.6$  cm   4 oz   113 grams

**NPL Certificates** will be supplied for the above thermometers if specially requested. For details see current price list.



## MINIMUM THERMOMETERS

The minimum thermometers used for meteorological observations have as their temperature measuring fluid a colourless spirit in which is placed a small glass index. When the thermometer is tilted with the bulb higher than the stem this index slides along the bore of the tube until it reaches the end of the spirit column where the surface tension prevents its breaking through the surface. With the thermometer mounted in the correct position—about 5° from the horizontal with the bulb downwards—a falling temperature will result in the index being carried back along the bore of the tube until the minimum temperature is reached. The index then remains stationary as the temperature rises ; thus the end of the index farthest from the bulb indicates the minimum temperature recorded since the thermometer was last set. Minimum thermometers, particularly the sheathed pattern which are used for “grass minimum” temperature measurements (see p 47), are provided with elongated safety chambers to allow them to be exposed to higher temperatures without damage. With this type of thermometer care should be taken that no spirit has become lodged in the safety chamber or upper part of the bore. Instructions are provided for remedying such trouble.



**Minimum Thermometer, Sheathed Pattern**, made to the requirements of the British Meteorological Office and to BS 692 : 1957. The thermometer stem is fused to an outer glass sheath which is completely sealed so that no condensation of moisture can take place on the thermometer scale.

Length  $13\frac{1}{2} \times \frac{1}{2}$  in  $34 \times 1.3$  cm  $2\frac{1}{2}$  oz 70 grams

	Schedule mark	Range	Divided to
W 3150	Min. 1/F	-10° to + 120°F	1°
W 3152	Min. 2/F	-30° to + 100°F	1°
W 3154	Min. 3/F	-50° to + 80°F	1°
W 3156	Min. 4/F	-90° to + 60°F	1°
W 3160	Min. 1/C	-25° to + 50°C	0.5°
W 3162	Min. 2/C	-35° to + 40°C	0.5°
W 3164	Min. 3/C	-50° to + 25°C	0.5°
W 3166	Min. 4/C	-70° to + 15°C	0.5°

**NPL Certificates** will be supplied for the above thermometers if specially requested. For details see current price list.



## MINIMUM THERMOMETERS

(continued)

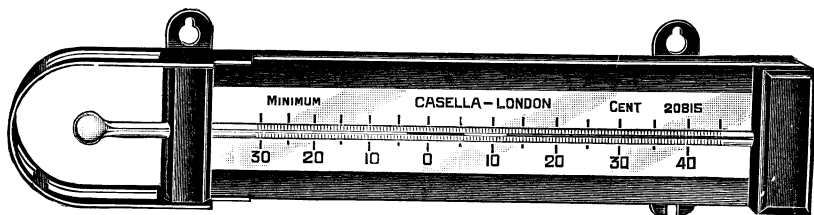

**Minimum Thermometer**, divided on solid stem and indelibly figured on a laminated plastic scale which has proved itself impervious to frosts and all effects of weather. The thermometer and scale are mounted on a polished mahogany frame fitted with brass hanging plates.

Fahrenheit Scale			Celsius Scale		
	Range	Divided to		Range	Divided to
W 3200	-10° to +120°	1°	W 3210	-25° to +50°	0.5°
W 3202	-30° to +100°	1°	W 3212	-35° to +40°	0.5°
W 3204	-50° to + 80°	1°	W 3214	-50° to +25°	0.5°
W 3206	-90° to + 60°	1°	W 3216	-70° to +15°	0.5°

13½ × 3½ × 1 in 34 × 9 × 2.5 cm 12 oz 340 grams

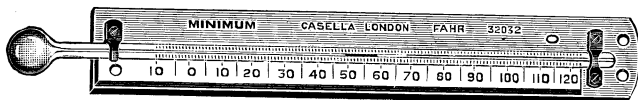

**Minimum Thermometer**, divided on solid stem, indelibly figured and mounted on strong laminated plastic scale drilled with holes for mounting in screen.

Fahrenheit Scale			Celsius Scale		
	Range	Divided to		Range	Divided to
W 3250	-10° to +120°	1°	W 3260	-25° to +50°	0.5°
W 3252	-30° to +100°	1°	W 3262	-35° to +40°	0.5°
W 3254	-50° to + 80°	1°	W 3264	-50° to +25°	0.5°
W 3256	-90° to + 60°	1°	W 3266	-70° to +15°	0.5°

11¼ × 1⅜ × ⅝ in 28.4 × 3.5 × 1.6 cm 4 oz 113 grams

**NPL Certificates** will be supplied for the above thermometers if specially requested. For details see current price list.



## ORDINARY THERMOMETERS

Both patterns illustrated are for measuring the dry bulb or wet bulb temperature when exposed in meteorological screens. The mounted pattern can also be used for measuring sea temperatures (see p 53). The sheathed pattern is similar in construction to the Maximum Thermometer described on p 42, except that there is no constriction in the bore of the tube and a button is provided at the top end. They are mercury filled with the exception of W 3306 and W 3316 which are spirit filled.

**Ordinary Thermometer**, sheathed pattern, made to the requirements of the British Meteorological Office and to BS 692 : 1957.

Length  $13 \times \frac{1}{2}$  in  $33 \times 1.3$  cm Weight  $2\frac{1}{2}$  oz 70 grams

	Schedule mark	Range	Divided to
W 3300	Ord. 1/F	0° to +130°F	1°
W 3302	Ord. 2/F	-20° to +110°F	1°
W 3304	Ord. 3/F	-40° to + 90°F	1°
W 3306	Ord. 4/F	-60° to + 70°F	1°
W 3310	Ord. 1/C	-20° to +55°C	0.5°
W 3312	Ord. 2/C	-30° to +45°C	0.5°
W 3314	Ord. 3/C	-40° to +35°C	0.5°
W 3316	Ord. 4/C	-55° to +20°C	0.5°



**Ordinary Thermometer**, divided on solid stem, indelibly figured and mounted on strong laminated plastic scale drilled with holes for mounting in screen.

Length  $11\frac{1}{4} \times 1\frac{3}{8} \times \frac{5}{8}$  in  $28.5 \times 3.5 \times 1.6$  cm 4 oz 113 grams

	Range	Divided to
W 3350	0° to +130°F	1°
W 3352	-20° to +110°F	1°
W 3354	-40° to + 90°F	1°
W 3360	-20° to + 55°C	0.5°
W 3362	-30° to + 45°C	0.5°
W 3364	-40° to + 35°C	0.5°

W 3370 **Threaded Muslin and Wick**, MO Pattern, for use with all thermometers on this page when used as wet bulbs.

**NPL Certificates** will be supplied for the above thermometers if specially requested. For details see current price list.





# TERRESTRIAL RADIATION

or

## GRASS MINIMUM THERMOMETER



The grass minimum temperature is the lowest temperature recorded by the thermometer when exposed just above ground covered by short grass, usually from sunset to sunrise. It thus gives a measurement of the radiation from the surface of the earth to space. It also provides information as to the occurrence of ground frosts. The thermometer should be exposed on the most open site available and can be mounted on the small stand W 3400 designed specially for this purpose. These thermometers are identical in every way to the sheathed pattern Minimum Thermometers described on p 44.

**Grass Minimum Thermometer**, made to the requirements of the British Meteorological Office and to BS 692 : 1957.

Length  $13\frac{1}{2} \times \frac{1}{2}$  in  $34 \times 1.3$  cm Weight  $2\frac{1}{2}$  oz 70 grams

	Schedule Mark	Range	Divided to
W 3150	Min. 1/F	-10° to+ 120°F	1°
W 3152	Min. 2/F	-30° to+ 100°F	1°
W 3154	Min. 3/F	-50° to+ 80°F	1°
W 3156	Min. 4/F	-90° to+ 60°F	1°
W 3160	Min. 1/C	-25° to+ 50°C	0.5°
W 3162	Min. 2/C	-35° to+ 40°C	0.5°
W 3164	Min. 3/C	-50° to+ 25°C	0.5°
W 3166	Min. 4/C	-70° to+ 15°C	0.5°

W 3400 **Exposure Stand**

**NPL Certificates** will be supplied for the above thermometers if specially requested. For details see current price list.





## EARTH THERMOMETERS

British Meteorological Office Patterns

In this country and many others in the British Commonwealth earth temperature is normally measured at one or more of the following depths, 2 in, 4 in, 8 in, 1 ft, 2 ft and 4 ft (approximately 5, 10, 20, 30, 60 and 120 cm). In exceptional cases temperatures are also measured at 10 ft (300 cm). On this and the following two pages we offer thermometers to cover all these requirements.

**Sheathed Earth Thermometer, Mk I (Symons pattern).** This is a mercury-in-glass solid stem thermometer fused into a stout glass tube with a sealed end surrounding the thermometer bulb. The bulb itself is embedded in a layer of paraffin wax to make it insensitive to changes of temperature as the thermometer is withdrawn to the surface for reading. To the top end of the glass tube is fitted a rosewood plug to which is screwed a brass eye for attaching a length of chain, on the other end of which is a metal cap. During use the thermometer is lowered into a length of seamless mild-steel tubing, pointed at one end for easy insertion into the ground. These tubes are made in varying lengths and in two patterns, one with a flange near the top end to ensure the correct amount of insertion and another without a flange, necessitating greater care when installing. In each case the length of the steel tube permits a six-inch projection above the earth surface, this projection accepting the copper cap at the end of the thermometer chain.

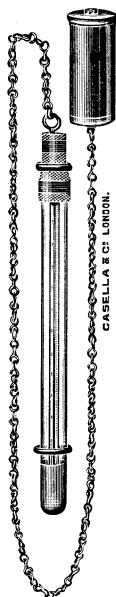

W 3450 **Sheathed Earth Thermometer, Mk I**, to British Meteorological Office specification, range 20 to 100°F, divided to 1°

W 3452 **Ditto**, range -5 to +40°C, divided to 0.5°

14 × 1¼ in 35.5 × 3.1 cm 6 oz 170 grams

**Steel Tubes** fitted with 3 in. (7.5 cm) diameter flange; each complete with copper cap and length of chain. For use at following depths:—

1 ft (30 cm)	2 ft (60 cm)	4 ft (120 cm)	10 ft (300 cm)
W 3460	W 3462	W 3464	W 3466

**Steel Tubes**, without flange, each complete with copper cap and length of chain:—

1 ft (30 cm)	2 ft (60 cm)	4 ft (120 cm)	10 ft (300 cm)
W 3470	W 3472	W 3474	W 3476

W 3480 **NPL Certificate**



## EARTH THERMOMETERS

(continued)

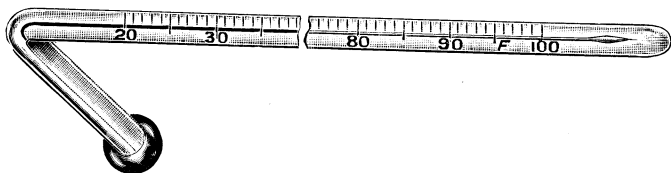

**Right Angled Earth Thermometers** T 5900, T 5904 and T 5908 are manufactured to a British Meteorological Office Specification while the remainder are either Celsius equivalents or offered to meet a proved demand. They are mercury-in-glass solid stem thermometers with the stem bent at right angles below the lowest graduation. In each case the scale bearing limb is of constant length, 8 in (20 cm), while the other limb varies in length according to the insertion required. The approximate diameter of the glass tube is  $\frac{1}{4}$  in (6 mm). The thermometers have spherical bulbs and are provided with safety chambers. No case or outer tube is required, the thermometer merely being inserted into a hole in the ground with the divided stem lying along the surface.

- T 5900 **Right Angled Earth Thermometer, Mk IC**, range 20° to 100°F, divided to 1°, for 2 in immersion
- T 5904 **Ditto, Mk IA**, for 4 in immersion ✓
- T 5908 **Ditto, Mk IB**, for 8 in immersion ✓
- T 5912 **Ditto**, for 12 in immersion
- T 5916 **Right Angled Earth Thermometer**, range -5° to +40°C, divided to 0.5°, for 5 cm immersion
- T 5920 **Ditto**, for 10 cm immersion
- T 5924 **Ditto**, for 20 cm immersion
- T 5928 **Ditto**, for 30 cm immersion
- T 5930 **NPL Certificate**
- W 3500 **Inspector's Earth Thermometer**, to British Meteorological Office Specification No. 419, range 30° to 85°F, divided to 1°, complete in slotted ebonite case provided with hollow steel tip and knurled brass screw cap, case engraved round periphery to indicate depth of insertion at 4 in (10 cm) and 8 in (20 cm). Thermometer calibrated for total immersion and provided with an NPL Certificate. Overall length approximately 16 in (40 cm).
- W 3502 **Ditto**, range 0° to 30°C, divided to 0.5°

## EARTH THERMOMETERS

(continued)

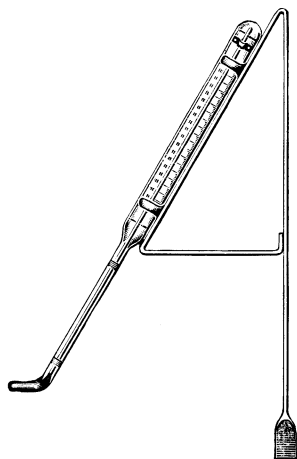

**Insulated Earth Thermometers** are offered to meet the demand experienced from several overseas Meteorological Departments. They are not in common use in Great Britain. Each thermometer has a tube mounted on an opal scale surrounded by an outer glass sheath. The scale portion is 12 in. (30 cm) long  $\times \frac{3}{4}$  in. (1.8 cm) diameter ; the stem below the scale varies in length according to the depth at which the temperature is to be measured. The stem is bent just above the bulb at such an angle that the cylindrical bulb lies in a plane horizontal to the ground surface when the thermometer is in its correct position on the metal support.

**Insulated Earth Thermometers,  $-10^{\circ}$  to  $+130^{\circ}\text{F}$ , divided to  $1^{\circ}$ ,** for the following depths :—

Surface	2 in	4 in	8 in	12 in	24 in	48 in
W 3550	W 3552	W 3554	W 3556	W 3558	W 3560	W 3562

**Ditto,  $-25^{\circ}$  to  $+55^{\circ}\text{C}$ , divided to  $0.5^{\circ}$ ,** for the following depths :

Surface	5 cm	10 cm	20 cm	30 cm	50 cm	100 cm
W 3570	W 3572	W 3574	W 3576	W 3578	W 3580	W 3582

**W 3590 Angle Bracket Mounting,** made of mild steel, painted black enamel

NB. Thermometers for depths other than those mentioned above will be specially manufactured on request.



## EARTH THERMOMETERS

(continued)

### Maximum and Minimum Thermometer, Six's pattern.

This thermometer is sometimes used for obtaining the maximum or minimum temperatures reached at a required depth since the last reading was taken. Since earth temperatures change slowly it is usually used in those circumstances when the frequency of observations is less than normal. The instrument consists of a stem divided tube mounted on a turned boxwood stick provided with an eyelet at the top for fixing a brass chain and copper cap similar to that used on a Sheathed Earth Thermometer. The thermometer can thus be lowered down a steel earth thermometer tube of the usual pattern (p. 48). Complete with magnet.

T 6138 Range 10° to 120°F, divided to 1°

T 6142 Range -10° to +50°C, divided to 0.5°

12 × 1¼ in 30.5 × 3.1 cm 3½ oz 100 grams



**Deep-Sea Thermometer.** The Casella-Miller Deep-Sea Thermometer, for registering the maximum and minimum temperatures of the sea to a depth of 3 miles, is designed to bear a pressure of 3 tons per square inch. Complete with magnet.

T 6146 Range 20° to 100°F, divided to 1°

T 6150 Range -5° to +40°C, divided to 0.5°

14 × 3 × 3 in 1½ lb

35.5 × 7.5 × 7.5 cm 0.6 kg

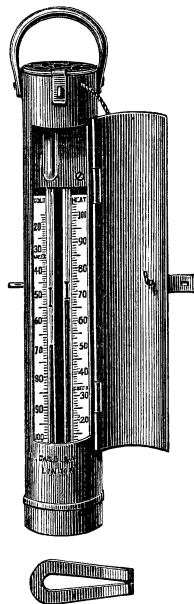



# THE PLANT CLIMATE THERMOMETER

(Prov. Pat. No. 24305/53)

For use in Great Britain only

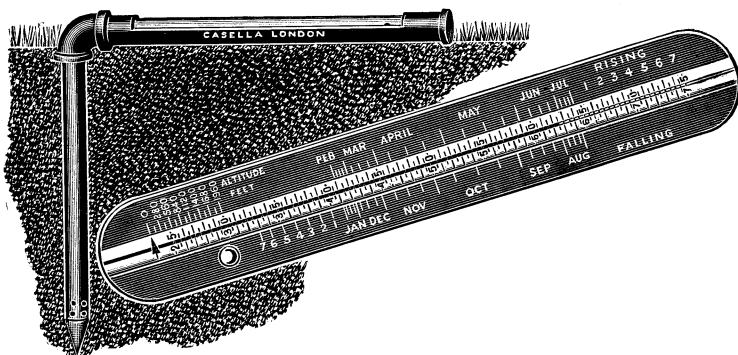

This thermometer, which was developed by Sidney A. Searle, consultant to the Horticultural Industry, is designed to assist the grower by showing the actual soil temperature 12 in below the ground surface as compared to the normal soil temperature for the time of the year at that depth. It thus acts as a guide to "planting time" in the Spring and enables the grower to take advantage of abnormally warm soil temperatures by planting earlier or warns him against planting too soon if the soil temperature is lower than normal for the time of year.

In addition to the above the thermometer:—

- (a) gives warning of frost in Spring and Autumn
- (b) gives information on imminent insect activity
- (c) acts as a guide to fuel consumption
- (d) indicates the performance to be expected from over-wintered crops

The calendar scales fitted to these thermometers are individually calibrated to the site on which the thermometer is to be used, the graduations being based on 12 in soil temperatures taken from Meteorological Office figures from about 1910 to 1954. For this reason it is important when ordering to state the area in which the thermometer is to be used so that the correct scale may be fitted.

- T 6000 **Plant Climate Thermometer** in brass case with open cover
- T 6004 **Plant Climate Thermometer** as above but with revolving cover to give added protection to tube

**Note :** Fuller details of the Plant Climate Thermometer and its uses will be found in our leaflet No. 803 and in Sidney A. Searle's book "The Measurement of Plant Climate", obtainable from us at 4s. 6d. per copy, post free.



## PROTECTOR CASES FOR AIR AND SEA-WATER THERMOMETERS

For Marine use

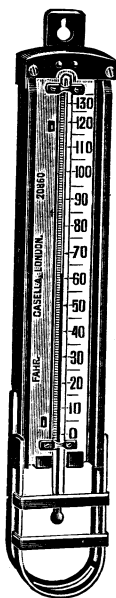

T 6320  
Air

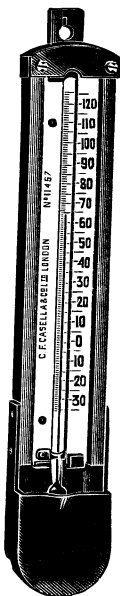

W 3600  
Sea-water

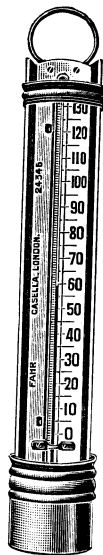

T 6316  
Sea-water

T 6320 is normally used for protecting ordinary thermometers mounted on laminated plastic mounts when used in Marine Thermometer Screens Mk III (p 61) on board ships. W 3600 and T 6316 are used for protecting similar thermometers when used in conjunction with canvas buckets for measuring sea-water temperatures from the sides of ships. T 6320 and W 3600 are both manufactured to British Meteorological Office Specifications. For convenience the illustrations show the cases with thermometers fitted, though the items below are for cases alone. For details of thermometers, see p. 46.

- T 6320 **Mahogany Case with Brass Guard**, for air temperature measurements
- W 3600 **Mahogany Case with Metal Cup**, for sea-water temperature measurements
- T 6316 **Copper Case**, for sea-water temperature measurements
- W 3610 **Meteorological Canvas Bucket Mk IIA**, for sea-water temperature measurements, with wood base and lid which is kept closed by a spring when in use
- |        |  |                                 |       |           |
|--------|--|---------------------------------|-------|-----------|
| T 6320 | $13\frac{1}{2} \times 2\frac{1}{4} \times 1\frac{1}{8}$ in | $34.3 \times 5.7 \times 2.9$ cm | 8 oz  | 225 grams |
| W 3600 | $13\frac{1}{2} \times 2\frac{1}{4} \times 1\frac{1}{2}$ in | $34.3 \times 5.7 \times 3.8$ cm | 12 oz | 340 grams |
| T 6316 | $13\frac{1}{4} \times 2 \times 1\frac{1}{2}$ in            | $33.6 \times 5.1 \times 3.8$ cm | 6 oz  | 150 grams |



## FRONDE THERMOMETER

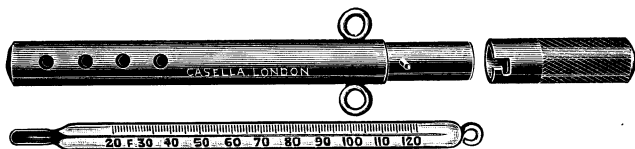

The **Fronde Thermometer** is a useful little instrument for ascertaining the true air temperature. Being small and well protected it can be carried in the pocket with complete safety. Each thermometer is of the solid-stem, mercury-filled type and is enclosed in a chromium-plated brass case with a bayonet-catch top and a perforated end piece surrounding the thermometer bulb. The thermometer in its case is whirled rapidly above the head about twelve times by means of a cord. The temperature is then read quickly before radiation effects alter the thermometer reading.

- T 6500 **Range** 20° to 120°F, divided to 1° ; length of case 4½ in
- T 6504 **Range** 10° to 130°F, divided to 1° ; length of case 6½ in
- T 6508 **Range** -5° to +50°C, divided to 0.5° ; length of case 11.5 cm
- T 6512 **Range** -10° to +55°C, divided to 0.5° ; length of case 16.5 cm
- T 6514 **NPL Certificate**

## INSPECTOR'S THERMOMETERS



These are reference thermometers for temperate and tropical use for determining the scale errors of other meteorological thermometers by comparison in a water bath. Each thermometer is a 12 in (300 mm) solid-stem mercury-in-glass type filled with inert gas at a suitable pressure. Each is calibrated for total immersion and is provided with a safety chamber. W 3650, W 3652 and W 3654 are manufactured to BS 2736 : 1956, while the remainder are Celsius equivalents.

- W 3650 **Inspector's Thermometer**, range 30° to 80°F, divided to 0.2° supplied in wooden case
- W 3652 **Ditto**, range 50° to 100°F, divided to 0.2°
- W 3654 **Ditto**, range 80° to 130°F, divided to 0.2°
- W 3660 **Ditto**, range -5° to +25°C, divided to 0.1°
- W 3662 **Ditto**, range 10° to 40°C, divided to 0.1°
- W 3664 **Ditto**, range 25° to 55°C, divided to 0.1°
- W 3670 **NPL Certificate**

## WALL THERMOMETERS

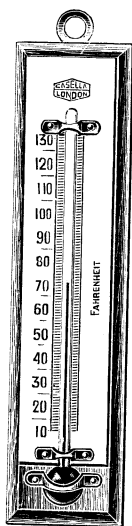

T 6224

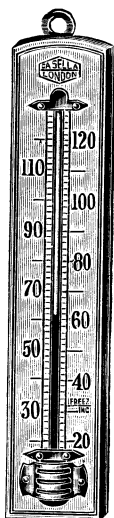

T 6232

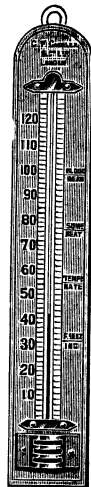

T 6240

- T 6224 **Thermometer, opal scale, on wood mount, mercury column, suitable for use outdoors, single scale, 10° to 130°F**
- T 6228 **Ditto, -10° to +55°C**  
 $8\frac{1}{4} \times 2$  in  $21 \times 5$  cm 6 oz 160 grams
- T 6232 **Boxwood Thermometer, bold figures, black spirit column, single scale, 20° to 120°F**
- T 6236 **Ditto, -5° to +50°C**  
 $8\frac{1}{2} \times 1\frac{5}{8}$  in  $22 \times 4$  cm 3 oz 80 grams
- T 6240 **Boxwood Thermometer, polished mount, mercury column, single scale, 20° to 120°F**
- T 6244 **Ditto, -5° to +50°C**  
 $8\frac{1}{2} \times 1\frac{1}{2}$  in  $22 \times 4$  cm 3 oz 80 grams





## SIX'S THERMOMETERS

In this pattern, invented by James Six in 1782, the maximum and minimum readings are obtained from one instrument. The tube is in the form of a U, having a bulb at each end, one bulb being completely filled with creosote or other liquid, the other only partially filled so as to act as a safety chamber. As the temperature rises the liquid in the filled bulb expands and pushes in front of it a column of mercury in the lower part of the U, having an iron index at each end. The indices remain at the farthest point to which they are pushed by the mercury as it travels backwards or forwards, and thus indicate both the maximum and minimum temperatures, readings being taken from the ends nearest the mercury. The indices are reset by means of a magnet.

Six's thermometers are sometimes rather troublesome to correct if they have been put out of order in transit. Swinging and tapping are the only remedies which the user can adopt as a rule. If these do not avail, or if either of the indices has become embedded in the mercury, it is necessary to return the thermometer.

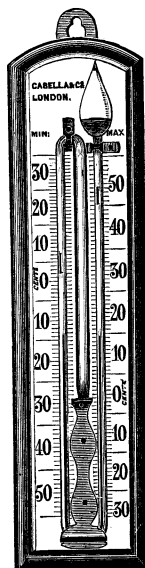

**Six's Thermometer**, opal glass or zinc scale, mounted on hardwood back, with magnet

### Opal Glass Scale

T 6050	10 in	Range $-30^{\circ}$ to $+130^{\circ}$ F
T 6054	25 cm	Range $-30^{\circ}$ to $+55^{\circ}$ C

### Zinc Scale

T 6058	10 in	Range $-30^{\circ}$ to $+130^{\circ}$ F
T 6062	25 cm	Range $-30^{\circ}$ to $+55^{\circ}$ C

$11 \times 2\frac{1}{2} \times 1$  in     $28 \times 6 \times 2.5$  cm    8 oz    220 grams



## SIX'S THERMOMETERS

(continued)

**Six's Thermometer, in white painted metal case, with magnet. Made in two sizes:—**

Length of scale 8 in (20 cm) overall 11 in (28 cm)  
 Length of scale 10 in (25 cm) overall 14 in (36 cm)

### Fitted with Opal Glass Scale

T 6066	8 in	Range -10° to +130°F
T 6070	10 in	Range -10° to +130°F
T 6074	20 cm	Range -25° to +60°C
T 6078	25 cm	Range -25° to +60°C

### Fitted with Boxwood Scale

T 6082	8 in	Range -10° to +130°F
T 6086	10 in	Range -10° to +130°F
T 6090	20 cm	Range -25° to +60°C
T 6094	25 cm	Range -25° to +60°C

### Fitted with Zinc Scale

T 6098	8 in	Range -10° to +130°F
T 6102	10 in	Range -10° to +130°F
T 6106	20 cm	Range -25° to +60°C
T 6110	25 cm	Range -25° to +60°C

### Copper Case in place of painted case

T 6114	8 in or 20 cm			
T 6118	10 in or 25 cm			
	11×3×2 in	28×7.5×5 cm	5 oz	150 grams
	14×3×2 in	36×7.5×5 cm	9 oz	250 grams

**Six's Thermometer, Tube mounted, divided and figured on the boxwood, with magnet**

T 6122	8 in	Range -10° to +130°F
T 6126	10 in	Range -10° to +130°F
T 6130	20 cm	Range -25° to +60°C
T 6134	25 cm	Range -25° to +60°C

9×2×1 in	23×5×2.5 cm	5 oz	150 grams
11×2×1 in	28×5×2.5 cm	7 oz	220 grams

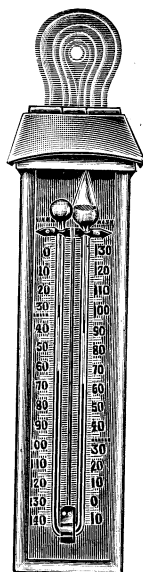

T 6098

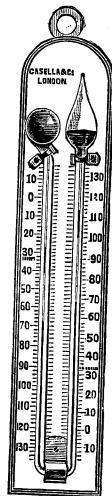

T 6122



## THERMOGRAPH

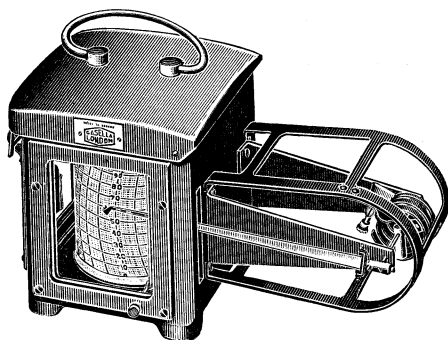

This is a robust and simple bi-metallic instrument for recording air temperatures within the range  $-50^{\circ}$  to  $+250^{\circ}\text{F}$  or  $-45^{\circ}$  to  $+120^{\circ}\text{C}$ . The charts normally stocked are for those ranges shown below, each covering  $100^{\circ}\text{F}$  or  $50^{\circ}\text{C}$ . Facilities are provided for the customer to raise or lower the  $100^{\circ}\text{F}$  or  $50^{\circ}\text{C}$  range of his instrument by up to  $50^{\circ}\text{F}$  or  $25^{\circ}\text{C}$ , thus making the thermograph suitable for use with more than one standard chart. If instruments are required to cover a wider range than  $100^{\circ}\text{F}$  or  $50^{\circ}\text{C}$  charts can be specially printed at a small extra cost.

The clock fitted to the thermograph is robust and has a long life. It can be supplied to rotate daily or weekly but in either case one full wind is sufficient for it to run for eight days.

A special feature of this instrument is that it can easily be corrected by the user if it should become out of adjustment during transit or from any other cause.

### STOCK CHARTS

Fahrenheit	Daily	Weekly	Celsius	Daily	Weekly
$-20^{\circ}$ to $+80^{\circ}$	T 9	T 19	$-30^{\circ}$ to $+20^{\circ}$	T 28	T 38
$-10^{\circ}$ to $+90^{\circ}$	T 1	T 11	$-20^{\circ}$ to $+30^{\circ}$	T 29	T 39
$0^{\circ}$ to $100^{\circ}$	T 2	T 12	$-10^{\circ}$ to $+40^{\circ}$	T 22	T 32
$10^{\circ}$ to $110^{\circ}$	T 8	T 18	$0^{\circ}$ to $50^{\circ}$	T 23	T 33
$20^{\circ}$ to $120^{\circ}$	T 3	T 13	$10^{\circ}$ to $60^{\circ}$	T 27	T 37
$30^{\circ}$ to $130^{\circ}$	T 4	T 14	$20^{\circ}$ to $70^{\circ}$	T 26	T 36
$50^{\circ}$ to $150^{\circ}$	T 5	T 15	$30^{\circ}$ to $80^{\circ}$	T 24	T 34
$80^{\circ}$ to $180^{\circ}$	T 6	T 16	$50^{\circ}$ to $100^{\circ}$	T 25	T 35

T 6550 **Thermograph, Daily**, with 55 charts, ink and instructions

T 6554 **Thermograph, Weekly**, with 55 charts, ink and instructions

$10 \times 6 \times 6\frac{1}{2}$  in

$25 \times 15 \times 16$  cm

6 lb 10 oz

3 kg



## ACCESSORIES FOR THERMOGRAPH

- T 6558 **Extra Charts**, 55
- T 6562 **Extra Charts**, 100
- T 6566 **Spare Bottle of Ink**
- T 6570 **Spare Clock**, Daily
- T 6574 **Spare Clock**, Weekly
- T 6578 **Set of Change Wheels**, to convert daily to weekly
- T 6582 **Set of Change Wheels**, to convert weekly to daily
- T 6586 **Spare Pen**
- T 6590 **Spare Pen Arm**
- T 6594 **Thermometer**, range  $-20^{\circ}$  to  $+100^{\circ}\text{F}$  divided to  $1^{\circ}$ , for checking instrument reading
- T 6598 **Ditto**, range  $10^{\circ}$  to  $130^{\circ}\text{F}$  divided to  $1^{\circ}$
- T 6602 **Ditto**, range  $50^{\circ}$  to  $180^{\circ}\text{F}$  divided to  $1^{\circ}$
- T 6606 **Ditto**, range  $-30^{\circ}$  to  $+40^{\circ}\text{C}$  divided to  $0.5^{\circ}$
- T 6610 **Ditto**, range  $0^{\circ}$  to  $70^{\circ}\text{C}$  divided to  $0.5^{\circ}$
- T 6614 **Ditto**, range  $30^{\circ}$  to  $100^{\circ}\text{C}$  divided to  $0.5^{\circ}$

We have recently effected a change in our clocks which will be of advantage to many users. By introducing a base cone fixed to the instrument, a very much shorter clock spindle can be employed than previously. This short spindle is now immune from bending if the instrument with the clock in it is subjected to shock in transit. This means that instruments may now be sent with the clock in position instead of it having to be packed separately. As a further improvement the spindle is made of stainless steel.

**Note :** When ordering it is important to state the temperature range and timing required.

## THERMOMETER SCREENS

To measure the true air temperature and relative humidity without influence from radiation it is necessary to expose the maximum, minimum and wet-and-dry bulb thermometers in specially constructed thermometer screens. Furthermore if temperatures recorded in different locations are to be comparable it is essential that the conditions for measurement shall be the same. The screens described on the following pages are designed to shield the thermometers from direct radiation from outside sources while permitting the free circulation of air around them. At the same time they shield the thermometers from precipitation, ensure as far as is possible a uniform temperature enclosure and prevent accidental damage. In practice thermometers may read high (up to  $+2^{\circ}\text{F}$ ) on calm sunny days and low (up to  $-1^{\circ}\text{F}$ ) on calm clear nights.

With the exception of the screen illustrated on page 64 their sides, back and front are double louvred; their roofs are double and their floors consist of overlapping boards separated vertically by an air space. Each screen is painted white to reduce radiation errors. This paint should be kept clean by periodic washing while the paint itself should be renewed approximately every two years. For details of exposure see introduction to this section (p 41).

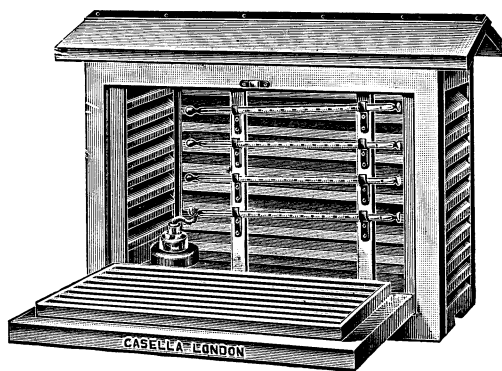

**W 3700 Small Thermometer Screen** (Bilham Pattern), British Meteorological Office pattern, with clips to take sheathed pattern maximum, minimum and wet-and-dry bulb thermometers (see pp 42, 44 and 46)

Inside dimensions  $16\frac{1}{2}$  in wide  $\times$   $6\frac{1}{4}$  in deep  $\times$  12 in high  
( $42 \times 16 \times 30$  cm)

Outside dimensions  $24 \times 11 \times 17$  in  $60 \times 28 \times 43$  cm

Weight 19 lb 8.6 kg

**W 3702 Iron Stand** for the above screen, British Meteorological Office pattern

$53 \times 17\frac{1}{2} \times 10$  in  $134 \times 44 \times 25$  cm 50 lb 22.6 kg

## THERMOMETER SCREENS

(continued)

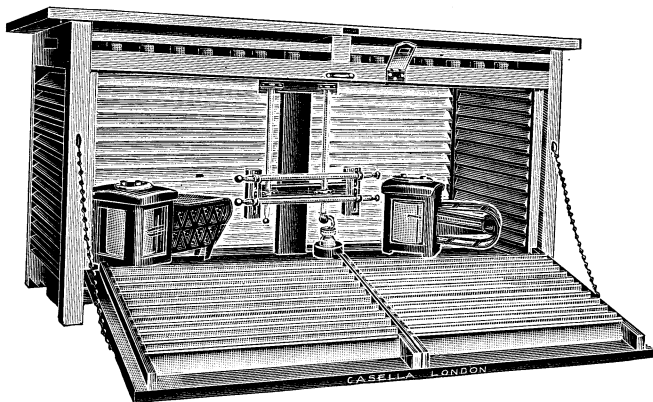

**W 3720 Large Thermometer Screen.** This screen is fitted with two doors, back and front, and has provision for accepting sheath pattern maximum, minimum and wet-and-dry bulb thermometers (pp 42, 44, 46 and 67). It also has sufficient space to house a thermograph (p 58) and a hygrograph (p 77)

Inside dimensions	39 × 11½ × 16½ in high	99 × 29.2 × 42 cm
Outside dimensions	48 × 19½ × 23 in	122 × 49.5 × 58.5 cm
Weight	86 lb	39 kg

**W 3722 Iron Stand** for the above screen

	54½ × 49 × 20 in	138 × 124 × 51 cm
Approx. weight	80 lb	36.3 kg

**W 3730 Marine Thermometer Screen**, for use on board ships. To house ordinary thermometers mounted on laminated plastic mounts (p 46) each fitted into an air-thermometer protector (p 53), for use as wet-and-dry bulb thermometers. Screen provided with stout metal ring for suspension

Inside dimensions	7 × 4 × 15 in high	17.7 × 10.2 × 38 cm
Outside dimensions	9 × 6 × 22 in	23 × 15.3 × 56 cm

## THERMOMETER SCREENS

(continued)

### Casella-Stevenson Pattern

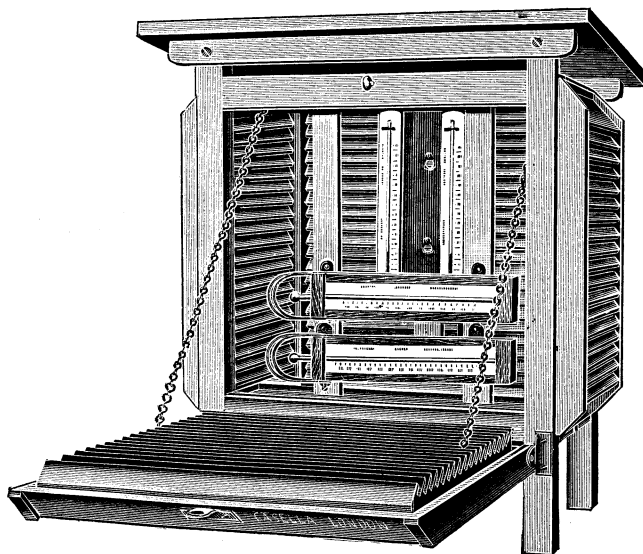

The Stevenson Screen illustrated on this page and on its stand on the following page is the most popular of the range described in this catalogue. By using a method of construction different from that employed when making screens to British Meteorological Office Specifications we are able to offer it at a relatively low price. Only the best seasoned wood is used and the quality of these screens has been proved in many parts of the world over a large number of years.

Although normally supplied to house a Kew Pattern Mason's Hygrometer (p 69) a Maximum Thermometer W 3050/66 (p 43) and a Minimum Thermometer W 3200/16 (p 45) this screen can also be supplied to house their sheathed pattern equivalents or their equivalents on laminated plastic mounts (pp 42 to 46, 67 and 68). Please state which when ordering.

**W 3750 Stevenson Screen**, complete with internal fittings for fixing thermometers and hygrometer

Inside dimensions	$17\frac{1}{2} \times 16 \times 9\frac{1}{2}$ in deep	$44.5 \times 40.5 \times 24$ cm
Outside dimensions	$26 \times 23 \times 16\frac{1}{2}$ in	$58 \times 54 \times 42$ cm
Weight	32 lb	14.5 kg

**W 3752 Iron Stand** for the above screen

$54 \times 19 \times 12$ in	$138 \times 48 \times 30$ cm
50 lb	22.6 kg



## THERMOMETER SCREENS

(continued)

Casella-Stevenson Pattern

**"MAKE-IT-YOURSELF KIT"**

Although, as stated on the previous page, this pattern screen is the most popular choice of all those we offer it is, even so, a relatively expensive item for private individuals or schools wishing to start a small meteorological station on a strictly limited budget. With this in mind we can now supply it as a "Make-it-Yourself Kit" in which all the parts are fully machined so that they may be readily assembled and secured with glue, screws or panel pins and afterwards painted. Only the minimum carpentry facilities, such as will be found in most schools and many homes, are required for this assembly work, while very detailed illustrated instructions are supplied with each kit. The only materials not included are glue and paint, both of which are easily obtained locally.

For schools it is anticipated that the educational value of children making their own screens will add to their subsequent interest in recording their meteorological observations.

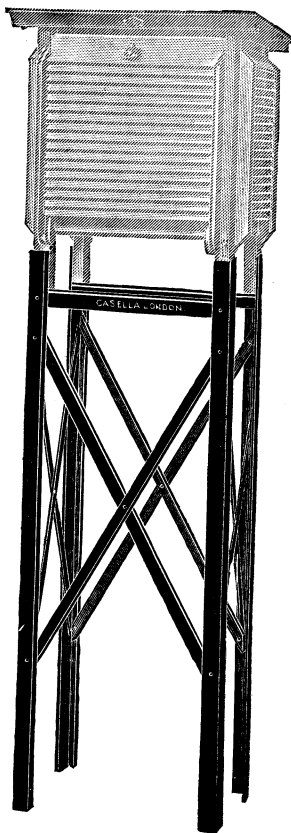

W 3750/1 **Stevenson Screen "Make-it-Yourself Kit"** complete with screws, panel pins, padlock and key, etc., together with instructions for assembly

*The kit described does not include the metal stand illustrated on this page. For details of the stand see page 62.*





## THERMOMETER SCREENS

(continued)

### SIMPLE METEOROLOGICAL OUTFIT

Suitable for Amateur use

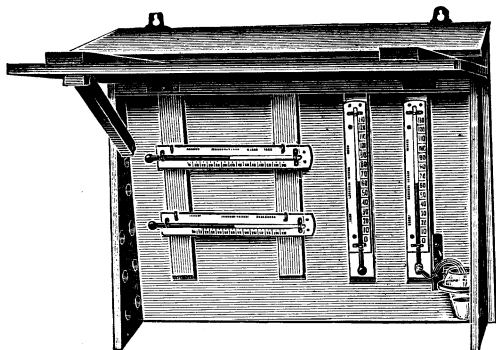

This outfit is not offered for serious meteorological work. It is certainly not suitable for those individuals who want their reports to be accepted by the Meteorological Office. It is offered primarily for those who are interested in meteorology as a hobby but who do not wish to go to the expense of buying the more expensive equipment described on other pages of this catalogue. It is, perhaps, suitable for use by schools, to enable students interested in weather to make a beginning in their studies of the subject.

The set consists of a wall screen made of hardwood, painted white and suitably battened to avoid warping, with a hinged front ; maximum, minimum and wet-and-dry bulb thermometers mounted on laminated plastic mounts (pp 43, 45 and 46), a simple 5 inch rain gauge and a pad of 12 monthly meteorological charts No. 790.

- W 3800 **Simple Meteorological Outfit**, complete with Fahrenheit thermometers, rain gauge and pad of meteorological charts
- W 3802 **Ditto**, with Celsius thermometers
- W 3804 **Ditto**, with Fahrenheit thermometers, but **without** rain gauge
- W 3806 **Ditto**, with Celsius thermometers, but **without** rain gauge
- W 3810 **NPL Certificates** for the 4 thermometers
- W 3812 **Wall Screen only**  
 $24 \times 20 \times 8\frac{1}{2}$  in     $60 \times 50 \times 21.5$  cm    17 lb    8.6 kg
- W 5100 **Rain Gauge**, inch reading
- W 5102 **Ditto**, millimetre reading
- W 3818 **Pad of Meteorological Charts**, No. 790



## SECTION 4

# HUMIDITY, DEW-POINT AND FROST-POINT

### CONTENTS

	Page
Dewpointer ... ..	80
Dew Point Apparatus ... ..	78
Frost Point Hygrometer ... ..	79
Hair Hygograph ... ..	77
Hair Hygrometer with thermometer ... ..	75
Humidity Slide Rule ... ..	75
Hygrometer, Assmann ... ..	72 to 74
"    , Kew pattern Mason's ... ..	69
"    , Mason's ... ..	70
"    , Wet-and-Dry Bulb, Sheathed Pattern ... ..	67
"    , "    "    "    , Simple Pattern ... ..	68
"    , Whirling ... ..	71
Thermo-Hygograph ... ..	76

### INTRODUCTION

THE instruments described in this section fall into three main groups :—

- (i) Wet-and-Dry Bulb Hygrometers
- (ii) Hair Hygrometers or Recorders
- (iii) Instruments for measuring Dew Point or Frost Point

#### (i) Wet-and-Dry Bulb Hygrometers

These instruments fall into two categories : (a) Non-aspirated and (b) aspirated types. The non-aspirated type of hygrometer consists of two thermometers mounted side by side, usually in a suitable meteorological screen. The dividing of the thermometers is sufficiently open for observers to estimate the position of the end of the mercury column to  $0.1^{\circ}$ . When making an observation the readings of the two thermometers should, as far as possible, be made simultaneously, after ascertaining that the wet bulb is receiving sufficient water from the reservoir mounted by its side. If the wick on the wet bulb has to be changed or the water reservoir filled this should be done between 15 and 30 minutes before a reading is to be taken, the actual period depending upon the difference in temperature between the water and the surrounding air.

Aspirated hygrometers are the Whirling Hygrometers (p 71) and Assmann Hygrometers (pp 72 to 74). One or both of these will normally be used on all synoptic stations. They are preferred to the non-ventilated type in view of the greater reliability which can be placed on the



results obtained from them. The Whirling Hygrometer, although considerably less expensive, is not so strongly recommended as our Assmann Hygrometer since its thermometers are not shielded against radiation effects and it is more subject to operational errors. It should be used in a place sheltered from direct solar radiation. Before a reading is taken it should be ensured that the wick on the wet-bulb is moist ; the instrument is then whirled at a rate of about 5 revolutions per second for a sufficient time to allow the thermometers to reach equilibrium. They should then be read rapidly, taking care to avoid radiation from the body effecting the results. The Assmann Hygrometer is used by suspending it from a post so that the two thermometer bulbs are at a height between 4 and 6 ft (1.25 to 2 m) above the ground. The motors provided in these instruments ensure a steady rate of aspiration until the equilibrium point of the wet and dry bulb thermometer is reached. Since the thermometer bulbs are surrounded by a highly polished double-walled radiation shield errors due to radiation are avoided.

#### (ii) **Hair Hygrometers and Recorders**

Since the rate of response of these instruments is very dependent on air temperature (at 15°F or -10°C the lag of the instrument is approximately 3 times greater than the lag at 50°F or +10°C) they are only recommended for use in situations or during periods where extreme temperatures and very low humidities are seldom to be found. They should always be exposed in a thermometer screen. When they are maintained in good condition with the hair and movement free from dust an accuracy of  $\pm 3$  per cent may be expected at moderate temperatures.

#### (iii) **Dew Point and Frost Point Measuring Instruments**

The dew point is the most accurate of the humidity measurements and in some circumstances is the only method which can be employed. Of the three instruments we offer, the simplest one is used to cover the range of dewpoints from 0°F to 120°F or -15°C to 50°C. The more complex instruments are to enable dew and frost points down to -130°F or -90°C to be measured.

## WET-AND-DRY BULB HYGROMETERS

**Wet-and-Dry Bulb Hygrometer, Sheathed Pattern**, recommended by the British Meteorological Office for use in their Small (p 60) and Large (p 61) Thermometer Screens, consists of 2 sheathed pattern ordinary thermometers manufactured to their requirements and to British Standard 692 : 1957. The bulb of one thermometer is covered by a circle of muslin round the edge of which is threaded cotton wick. The two ends of the wick pass down into a reservoir containing distilled water, or rain water. Capillary action causes the water to pass up the wick and keep the muslin constantly wet. This threaded muslin wick must be frequently changed if accurate results are to be obtained.

The pair of thermometers is mounted vertically in the Large Screen and horizontally in the Small Screen

- W 4000 **Wet-and-Dry Bulb Hygrometer, Sheathed pattern**, range 0° to 130°F, divided to 1°, a water reservoir with metal cap, and a threaded muslin wick
- W 4002 **Ditto**, range -20° to +110°F, divided to 1°
- W 4004 **Ditto**, range -20° to +55°C, divided to 0.5°
- W 4006 **Ditto**, range -30° to +45°C, divided to 0.5°
- W 4008 **Two NPL Certificates** for thermometers
- T 8556 **Tables** for use with Fahrenheit thermometers (MO 265)
- T 8560 **Tables** for use with Celsius thermometers
- T 8564/1 **Humidity Slide Rule Mk IV** (see p 75) for use with Fahrenheit thermometers
- T 8566 **Ditto, Mk 5**, for use with Celsius thermometers
- T 8568 **MO Pattern Threaded Wick**
- W 4010 **Spare Glass Water Reservoir**, without cap
- W 4012 **Spare Metal Cap**

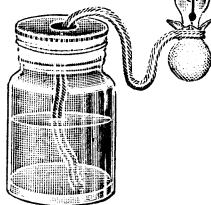
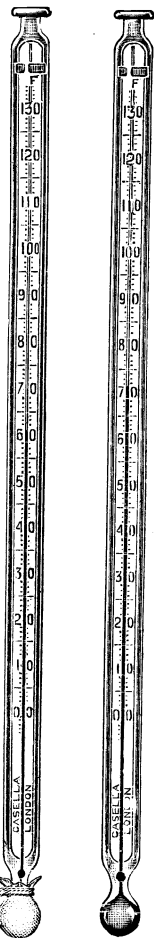

*For spare thermometers see page 46*



## WET-AND-DRY BULB HYGROMETERS

(continued)

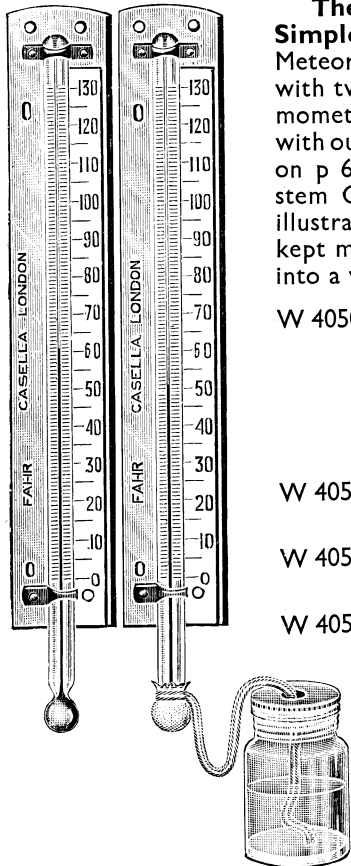

The **Wet-and-Dry Bulb Hygrometer, Simple pattern**, is recommended by the British Meteorological Office for use in conjunction with two cases T 6320 (p 53), in Marine Thermometer Screens Mk III (p 61). It is also used with our Simple Meteorological Outfit described on p 64. The Hygrometer consists of 2 solid stem Ordinary Thermometers similar to those illustrated. The bulb of one thermometer is kept moist by means of a threaded wick dipped into a water reservoir.

W 4050 **Wet-and-Dry Bulb Hygrometer, Simple pattern**, comprising 2 solid-stem Ordinary Thermometers range 0° to 130°F, divided to 1°, a water reservoir with cap and metal support and a threaded muslin wick

W 4052 **Ditto**, range -20° to +110°F, divided to 1°

W 4054 **Ditto**, range -20° to +55°C, divided to 0.5°

W 4056 **Ditto**, range -30° to +45°C, divided to 0.5°

W 4058 **Two NPL Certificates** for thermometers

T 8556 **Tables** for use with Fahrenheit thermometers (MO 265)

T 8560 **Tables** for use with Celsius thermometers

T 8564/1 **Humidity Slide Rule, Mk IV** (see p 75) for use with Fahrenheit thermometers

T 8566 **Ditto, Mk 5**, for use with Celsius thermometers

T 8568 **MO Pattern Threaded Wick**

W 4010 **Spare Glass Water Reservoir**, without cap

W 4012 **Spare Metal Cap**

For spare thermometers see page 46



## MASON'S HYGROMETER

### KEW PATTERN

The Kew Pattern Mason's Hygrometer is the type of hygrometer which we recommend for use in our Stevenson Screen pp 62 and 63. It consists of 2 British Meteorological Office pattern Ordinary Thermometers mounted on laminated plastic mounts, (see p 46) themselves mounted on a black laminated plastic board to give a robust support and pleasing finish. Attached to the bottom of the board is a metal support for a glass water reservoir into which the wick from the wet bulb thermometer passes through a metal cap.

W 4100 **Mason's Hygrometer, Kew pattern**, range  $0^{\circ}$  to  $130^{\circ}\text{F}$ , divided to  $1^{\circ}$ , complete with water reservoir and threaded muslin wick for wet bulb

W 4102 **Ditto**, range  $-20^{\circ}$  to  $+110^{\circ}\text{F}$ , divided to  $1^{\circ}$

W 4104 **Ditto**, range  $-20^{\circ}$  to  $+55^{\circ}\text{C}$ , divided to  $0.5^{\circ}$

W 4106 **Ditto**, range  $-30^{\circ}$  to  $+45^{\circ}\text{C}$ , divided to  $0.5^{\circ}$

W 4108 **Two NPL Certificates** for thermometers

T 8556 **Tables** for use with Mason's Hygrometer (MO 265) Fahrenheit

T 8560 **Tables** for use with Mason's Hygrometer, Celsius

T 8564/1 **Humidity Slide Rule, Mk IV** (see p 75), for use with Fahrenheit thermometers

T 8566 **Ditto, Mk 5**, for use with Celsius thermometers

T 8568 **MO Pattern Threaded Wick**

W 4110 **Spare Glass Water Reservoir**, without cap

W 4112 **Spare Metal Cap** for water reservoir

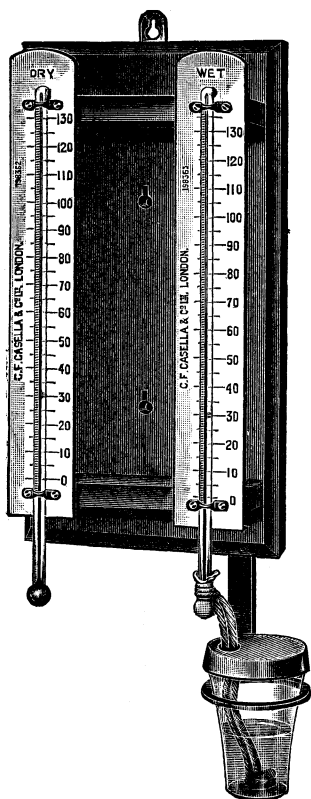

*For spare thermometers see page 46*



## MASON'S HYGROMETER

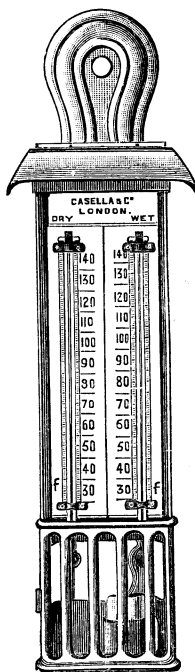

T 8500

As already stated in the introductory matter to this section the accuracy of a wet-and-dry bulb hygrometer largely depends upon the constancy and rate of air flow past the two bulbs. Mason's Hygrometers of the type illustrated on this page are rarely used in thermometer screens but are more often used on open sites or in buildings such as greenhouses where the air flow fluctuates considerably. For this reason, and because the thermometers are not stem divided, these instruments cannot be considered suitable for accurate work. We only recommend them when a rough guide to humidity changes is all that will be required.

**Mason's Hygrometer**, in white painted metal case, with guard to protect the bulb and reservoir ; Made in two sizes :—

### 8 in (20 cm) scale

14 × 3 × 2 in    36 × 7.5 × 5 cm    10 oz    280 g

### 10 in (25 cm) scale

16 × 3 × 2 in    40 × 7.5 × 5 cm    14 oz    390 g

Opal Scale	Boxwood Scale	Zinc Scale	
T 8500	T 8516	T 8532	8 in Scale, range 30° to 140°F
T 8504	T 8520	T 8536	10 in Scale, range 30° to 140°F
T 8508	T 8524	T 8540	20 cm Scale, range 0° to 60°C
T 8512	T 8528	T 8544	25 cm Scale, range 0° to 60°C
T 8548	<b>Copper Case</b> , in place of white painted case, 8 in or 20 cm		
T 8552	<b>Copper Case</b> , in place of white painted case, 10 in or 25 cm		
T 8556	<b>Tables</b> for Mason's Hygrometer, Fahrenheit (MO 265)		
T 8560	<b>Tables</b> for Mason's Hygrometer, Celsius		
T 8564/1	<b>Humidity Slide Rule, Mk IV</b> (see p 75), for use with Fahrenheit thermometers		
T 8566	<b>Ditto, Mk 5</b> , for use with Celsius thermometers		
T 8568	<b>Threaded Wick</b> for wet bulb		
T 8572	<b>Spare Water Bottle</b>		



## WHIRLING HYGROMETER

As mentioned in the introduction to this section ventilating the wet bulb gives greater accuracy of relative humidity determination. In this instrument the frame has a polythene reservoir at one end into which the wet bulb wick dips, thus keeping it continually moistened. Distilled water should always be used for wetting the wick which must be kept in good condition and changed frequently.

After whirling rapidly for 15–20 seconds the thermometers are read quickly, the wet bulb first, and then whirled again. This is repeated until two consecutive readings are the same, when the depression of the wet bulb against the dry bulb reading will give the relative humidity from tables. During whirling, the hygrometer should be shielded from solar radiation and held as far from the body as possible with the hygrometer up-wind if wind is present. It is sometimes advisable in still air to step backwards and forwards while whirling, since the presence of the hygrometer and the observer may set up local variations in humidity.

The thermometers are mercury filled, divided on the stem with lens fronts, and have a scale length of about 4 in (100 mm). Spirit-filled thermometers or special ranges can be supplied to order.

This instrument is manufactured to BS 2842: 1957.

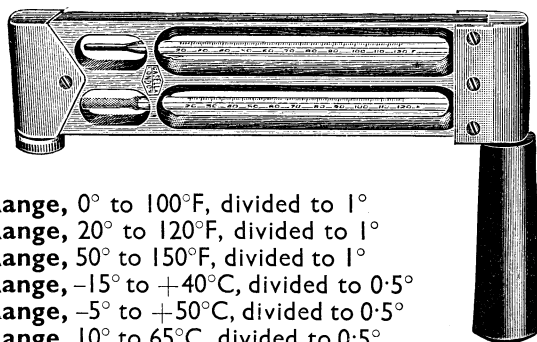

- T 8700 **Range, 0° to 100°F, divided to 1°**
- T 8704 **Range, 20° to 120°F, divided to 1°**
- T 8708 **Range, 50° to 150°F, divided to 1°**
- T 8712 **Range, -15° to +40°C, divided to 0.5°**
- T 8716 **Range, -5° to +50°C, divided to 0.5°**
- T 8720 **Range, 10° to 65°C, divided to 0.5°**
- T 8724 **Leather Sling Case**
- T 8728 **Tables, Fahrenheit (Marvin's)**
- T 8732 **Tables, Celsius**
- T 8564/1 **Humidity Slide Rule, Mk IV (see p 75), for use with Fahrenheit thermometers**
- T 8566 **Ditto, Mk 5, for use with Celsius thermometers**
- T 8740 **NPL Certificate for one thermometer**
- T 8744 **Spare Thermometer, 6½ in (16.5 cm), state range**
- T 8748 **Spare Wicks, each**
- T 8752 **Spare Wick, per yard**

$8\frac{1}{4} \times 6\frac{3}{4} \times 1\frac{1}{4}$  in     $21 \times 17 \times 3$  cm     $7\frac{1}{2}$  oz    200 grams  
 In case, 1 lb    450 grams





## ASSMANN HYGROMETERS

This Hygrometer is an improved version of the well-known Assmann Hygrometer. It has been redesigned by the British Meteorological Office and is now made to their latest specification. This redesign has given it greater accuracy and a longer life, without altering its basic principles. It is a special form of wet-and-dry bulb hygrometer in which the bulbs are kept ventilated by means of a fan until an equilibrium point is reached. Of all the wet-and-dry bulb instruments it can be considered the most accurate and most free from operational errors. It is therefore often used as a standard against which other humidity measuring instruments are compared.

The hand, spring or electrically driven fans fitted to the instrument are designed to give a rate of aspiration which ensures a more constant depression of the wet bulb and a more accurate value of the relative humidity than was possible with the earlier model.

The thermometers are held in a metal frame comprising a central metal tube terminating in a hollow U. The thermometer stems pass into the U through O-rings which seal the holes. The bulbs are centrally held in double-tubed radiation shields. The fan for providing the aspiration, driven by hand, clockwork or electricity, is attached to the upper end of the frame.

All three instruments are normally supplied in polished wood cases with compartments to take the necessary accessories. The instruments fitted with spring and electrically driven fans can, as an alternative, be supplied in cases made from laminated plastic sheet. These latter cases are practically unbreakable and being chemically inert are completely suitable for tropical use. They will not split, warp or discolour and will not suffer attack from the usual enemies of wood.

Solid-stem or insulated pattern thermometers can be supplied. Many users prefer the insulated pattern because the close proximity of the capillary to the scale reduces errors due to parallax. Also the scale divisions and figures, being on flat opal, are easier to read and being enclosed in an outer sheath remain clear and distinct throughout the life of the thermometer.



## ASSMANN HYGROMETERS

(continued)

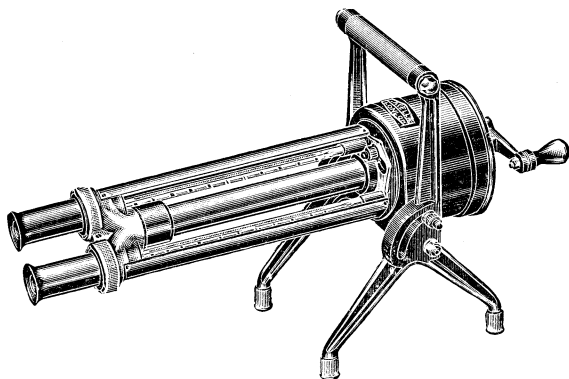

Hand Drive  
T 8916/1

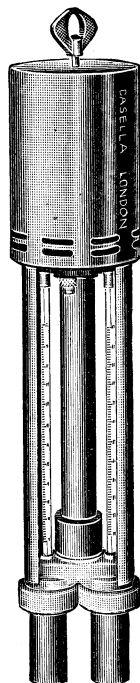

Clock or Electric Drive  
T 8900/1 or T 8908/1

**Assmann Hygrometers Mk 3**, British Meteorological Office patterns, each supplied in a polished wood case with two thermometers, length of wick, wick moistener and suspension rod :—

- T 8900/1 **Spring Driven Fan**, with insulated thermometers
- T 8904/1 **Ditto**, with solid stem thermometers
- T 8908/1 **Electrically Driven Fan**, 110 v or 200/250 v AC with insulated thermometers
- T 8912/1 **Ditto**, with solid stem thermometers  
22½ × 4½ × 4½ in 57 × 11.5 × 11.5 cm 10½ lb 4.76 kg
- T 8914 **Laminated Plastic Case** in place of wood case for T 8900/1 to T 8912/1 (add /8914 to reference number selected from above)
- T 8916/1 **Hand Drive**, with insulated thermometers
- T 8920/1 **Ditto**, with solid stem thermometers  
20 × 8 × 7 in 51 × 20 × 18 cm 13 lb 5.9 kg

Please state the range of Thermometers required from the list on the next page



## ASSMANN HYGROMETERS

(continued)

### Temperature ranges normally available

Fahrenheit divided to 1°	Celsius divided to 0.5°
0° to 100°	-15° to +40°
20° to 120°	-5° to +50°
40° to 140°	5° to 60°
50° to 150°	10° to 65°

We shall be pleased to quote for any special ranges required

- T 8924 **Spare Thermometer, insulated pattern**, to any of the above ranges
- T 8928 **Spare Thermometer, solid stem**, to any of the above ranges
- T 8932 **NPL Certificate**
- T 8728 **Tables, Fahrenheit** (Marvin's)
- T 8732 **Tables, Celsius**
- T 8944 **Spare Wicks**, each
- T 8948 **Spare Wick**, per yard
- T 8952 **Reading Microscope** for thermometers
- T 8564/1 **Humidity Slide Rule, Mk IV** (see p 75), for use with Fahrenheit thermometers
- T 8566 **Ditto, Mk 5**, for use with Celsius thermometers
- T 8960 **Spare Spring Driven Motor**, in housing
- T 8964 **Spare Electrically Driven Motor**, in housing
- T 8968 **Spare Spring** in barrel for T 8960
- T 8972 **Spare Spring** only for T 8960

*A more comprehensive description of the Assmann Hygrometers will be found in a separate leaflet which can be obtained from us on request*



## HUMIDITY SLIDE RULE



This slide rule, made to the design of the British Meteorological Office, enables the relative humidity, dew point, frost point, vapour pressure, mixing ratio and absolute humidity to be computed quickly and easily from psychrometer observations. It consists of a stock and slide with scales on the front and back of each. It is made of an ivory plastic which is impervious to changes of humidity and temperature. The total temperature range covered by the seven scales provided is from  $-130^{\circ}$  to  $+110^{\circ}\text{F}$  ( $-90^{\circ}$  to  $+43^{\circ}\text{C}$ )

T 8564/1 **Humidity Slide Rule, Mk IV**, for use with Fahrenheit thermometers, complete with case and operating instructions

T 8566 **Ditto, Mk 5**, for use with Celsius thermometers  
 $12 \times 2\frac{1}{2} \times \frac{3}{4}$  in     $30.5 \times 6.3 \times 1.9$  cm    11 oz    340 grams

## HAIR HYGROMETER

with Thermometer

From this instrument both the temperature and humidity may be read at a glance. The humidity element is a bundle of carefully prepared human hair; the dial on which the relative humidity is indicated is 4 in (10 cm) diameter. Accuracy about 5%

T 9100 **Hygrometer** fitted with Fahrenheit thermometer range  $0^{\circ}$  to  $120^{\circ}\text{F}$

T 9104 **Ditto**, fitted with Celsius thermometer range  $-5^{\circ}$  to  $+50^{\circ}\text{C}$   
 $9\frac{1}{2} \times 4\frac{1}{2} \times \frac{3}{4}$  in     $24 \times 12 \times 2$  cm  
1 lb    0.45 kg

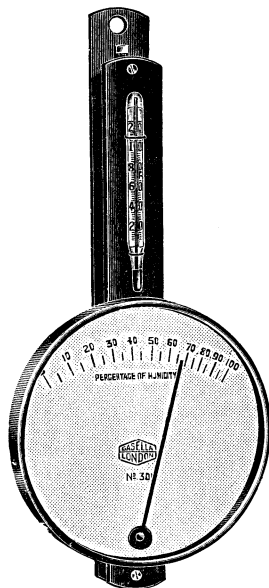



## THERMO - HYGROGRAPH

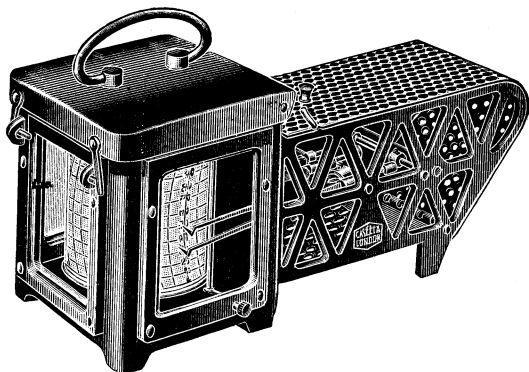

In this recorder temperature and percentage of humidity are both recorded in different coloured inks on the same chart, thus enabling a comparison to be easily made. Provision is also made for both the temperature and humidity elements to be readily adjusted so that the instrument may be regularly checked against a whirling or aspirated hygrometer. The instrument is compact, light in weight and very robust, while the clock is made with a short stainless steel spindle sufficiently strong to withstand shocks during transit. The instrument can therefore be despatched by post with the clock in position. It can be used in the Large Thermometer Screen (p 61), or in our Stevenson Screen (pp 62 and 63) with the position of the thermometer supports set farther back.

T 9150 **Thermo-Hygrograph, daily**, with 55 charts, and two bottles of ink

T 9154 **Thermo-Hygrograph, weekly**, with 55 charts, and two bottles of ink

14×6×6½ in    35×15×16 cm    7 lb    3.2 kg

### STOCK SERIES OF CHARTS

On all our charts the temperature range is overprinted on a basic chart ranged 0 to 100% RH. Please select from the temperature ranges given below that which will best suit your purpose. Charts are offered with either **Daily** or **Weekly** timings, in either case the clocks only need rewinding every 8 days.

Fahrenheit	Daily	Weekly	Celsius	Daily	Weekly
-10° to +90°	451	478	-25° to +25°	298	348
0° to 100°	398	511	-10° to +40°	450	514
10° to 110°	548	552	-5° to +45°	344	463
20° to 120°	382	516	0° to 50°	449	513
30° to 130°	314	517	10° to 60°	367	549
50° to 150°	468	508	30° to 80°	346	465
80° to 180°	343	522	50° to 100°	347	471

For details of spares for the above instrument, see page 77

*A more comprehensive description of the Thermo-Hygrograph will be found in a separate leaflet which can be obtained from us on request*



## HAIR HYGROGRAPH

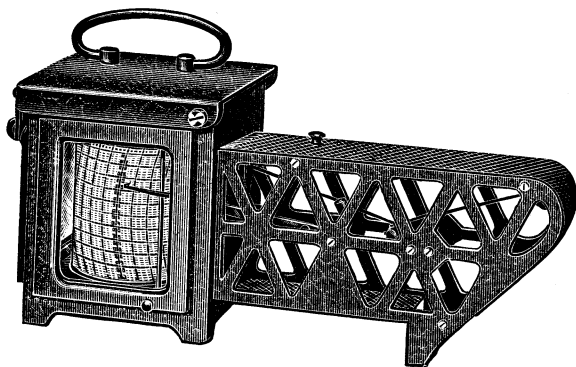

This recorder is similar in design to our Thermo-Hygrograph T 9150 except that there is no temperature element. The relative humidity is recorded over the range 0 to 100% on an even scale, while both daily and weekly charts are available. The clock fitted is similar to that incorporated in the Thermo-Hygrograph, making the instrument safe for transit with the clock in position. The instrument is suitable for those individuals and organisations who are only interested in relative humidity or who prefer to use two separate instruments for recording temperature and relative humidity. For recorders of temperature only see page 58 in Section 3.

T 9200 **Hair Hygrograph, daily**, with 55 charts No. 398, and one bottle of ink

T 9204 **Hair Hygrograph, weekly**, with 55 charts No. 511, and one bottle of ink

14 × 6 × 6½ in    35 × 15 × 16 cm    6½ lb    3 kg

### SPARE PARTS FOR THERMO-HYGROGRAPHS AND HYGROGRAPHS

- T 9208 **Extra Charts, 55** 11¾ × 3⅞ in (30 × 9 cm)
- T 9212 **Extra Charts, 100**
- T 6570 **Clock, Daily** (26 hours) wound once a week
- T 6574 **Clock, Weekly** (8 days)
- T 6578 **Set of Change Wheels**, to convert daily to weekly
- T 6582 **Set of Change Wheels**, to convert weekly to daily
- T 9228 **Pen**, long pattern, for humidity
- T 6586 **Pen**, short pattern, for temperature
- T 9236 **Pen Arm**, for temperature element
- T 9240 **Pen Arm**, for humidity element
- T 6566 **Bottle of Ink**
- T 9248 **Bundle of Prepared Hairs**
- T 9252 **Spring** for humidity cams

## DEW POINT APPARATUS

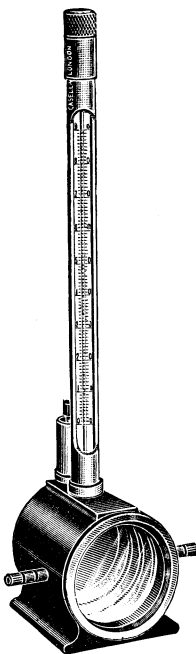

T 9300

This is a simple, easily used dew point instrument suitable for finding the dew point or relative humidity in small spaces, since a sample can be withdrawn and held in the sample chamber of 10 ml capacity. It is, however, more accurate and easier to operate when air or gas is kept flowing through the sample chamber. This chamber is separated from the ether chamber by a thin, polished stainless steel disc on which the dew forms. The body of the instrument is made of a plastic moulding which enables the mirror to be cooled and warmed again as quickly as possible. The thermometer is of the insulated pattern with its bulb near the mirror, having a scale length of 5 in (12.5 cm) to allow quick, accurate readings. The ether is evaporated by bubbling air through it from a rubber aspirator, a restriction in the pipe giving close control of the cooling rate. The construction of the instrument allows the observation window and mirror to be removed by merely unscrewing the front ring so that cleaning becomes an easy matter.

$9\frac{3}{4} \times 3\frac{1}{4} \times 2\frac{1}{4}$  in     $24.7 \times 8.3 \times 5.7$  cm     $7\frac{1}{2}$  oz    213 g

- T 9300    **With Fahrenheit Thermometer, 0° to 90° in 1°**
- T 9304    **With Fahrenheit Thermometer, 30° to 120° in 1°**
- T 9308    **With Celsius Thermometer, -15° to +35° in  $\frac{1}{2}$ °**
- T 9312    **With Celsius Thermometer, 0° to 50° in  $\frac{1}{2}$ °**
- T 9316    **Rubber Aspirator for use with above**
- T 9320    **Spare Thermometer, state range**
- T 9324    **NPL Certificate**

*A more comprehensive description of the Dew Point Apparatus will be found in a separate leaflet which can be obtained from us on request*

## FROST POINT HYGROMETER

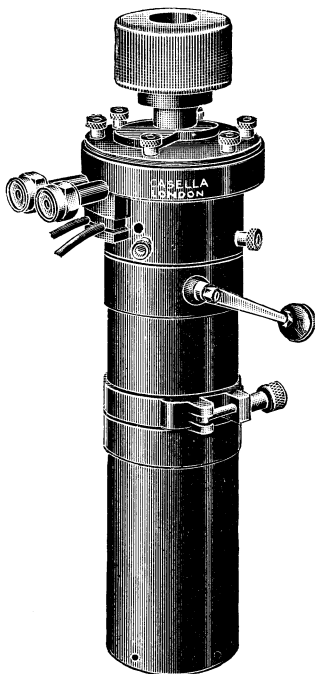
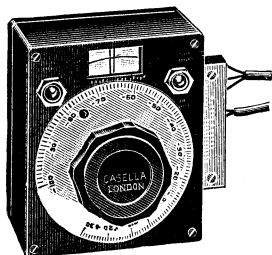

This hygrometer was primarily designed for the accurate measurement of frost points in the upper air. For this purpose it is carried by aircraft either with or without pressurised cabins. It may however be used for any measurement of frost points as its range extends down to  $-130^{\circ}\text{F}$  ( $-90^{\circ}\text{C}$ ).

The principle of operation is that the air or gas is passed in a narrow stream across a highly polished anodised aluminium thimble round the sides of which is wound a platinum resistance thermometer. Liquid air or nitrogen is pumped in a controlled stream up to the inside of the thimble to reduce it to the temperature of the frost point. The ice crystals are observed by an ingenious form of glancing illumination, the temperature at which the crystals are just maintained being measured on a balanced bridge potentiometer having a dial marked in degrees.

The air may be drawn through copper tubing from a source remote from the instrument and the vacuum flask containing the liquid nitrogen may be changed, both without any risk of contamination from the air surrounding the instrument.

- T 9358/1 **Frost Point Hygrometer**, British Meteorological Office pattern, Mk 3, for use down to  $-130^{\circ}\text{F}$ . Battery illumination
- T 9362/1 **Ditto**, but Celsius scale down to  $-90^{\circ}\text{C}$
- T 9374/1 **Frost Point Hygrometer**, as T 9358/1 but 50 cycles AC mains illumination
- T 9378/1 **Frost Point Hygrometer**, as T 9362/1 but 50 cycles AC mains illumination

*A more comprehensive description of the Frost Point Hygrometer Mk 3 will be found in a separate leaflet which can be obtained from us on request*





## DEWPOINTER

(Brit. Pat. No. 641555)



This instrument is the latest addition to our range of humidity measurers and works on quite a different principle from any other. The air to be tested is pumped into an observation chamber by a self-contained pump in the instrument. After a short pause for temperature equalisation the pressure is suddenly released with near-adiabatic conditions which results in the formation of a cloud of water droplets if the pressure were high enough. A gauge reading in pressure ratios, connected to the observation chamber, is used to determine, by successive trials, the end point where a cloud is only just formed. From this reading and that of the initial temperature the dew or frost point is determined by the use of a simple calculator. The instrument is completely self-contained and needs only a dry battery to provide light for observation of the cloud. If desired it may be used from AC mains. The calculator is made for the Fahrenheit scale but has an easily read conversion to Celsius readings on the back. The range of dew and frost points measurable is from room temperatures down to about  $-80^{\circ}\text{F}$  ( $-62^{\circ}\text{C}$ ).

T9342 **Dewpointer** for use from a battery in a case with calculator, instructions, spare gauge oil, glass wool for the inlet filter, pipe connectors and spanner

*A more comprehensive description of the Dewpointer will be found in a separate leaflet which can be obtained from us on request*



## SECTION 5

# PRECIPITATION AND EVAPORATION

## CONTENTS

	Page		Page
Duvdevani Dew Gauge ...	100	Rain Gauges	
Evaporation Hook Gauge ...	103	8-inch Splayed Base ...	86
Evaporation Indicators ...	102	Measuring Jars ...	87 & 88
Piche Evaporimeter ...	101	Inner Bottles ...	88
Rain Gauges		Rainfall Recorders	
5-inch Snowdon ...	82	Natural Siphon ...	89 to 91
5-inch Splayed Base ...	83	Tilting Siphon ...	92 to 93
5-inch Howard ...	83	Jardi Rate-of- ...	94 & 95
5-inch Bradford ...	84	95-Day ...	96 & 97
5-inch Octapent ...	85	Electrical ...	98 & 99
8-inch Cylindrical Base ...	86	Water Flow Meter ...	104

## INTRODUCTION

THE range of instruments included in this section cover the majority of the requirements of both synoptic and climatological stations for precipitation and evaporation measurements. The non-recording raingauges offered vary in capacity, material used in their construction, and in design. The choice of capacity will vary according to the rate of rainfall to be expected and the frequency with which the gauge may be visited. The question of material preferred for their construction has two aspects to be considered: firstly the choice of basic materials—copper or galvanized iron—the first of which is more expensive but has a longer life; and secondly the choice of an instrument manufactured to a British Meteorological Office Specification or its commercial equivalent. Specification gauges have their cylindrical top portions and their inner cans made from either seamless drawn copper tube or brazed copper tube, thus ensuring that when a large number of gauges is in use their funnels are interchangeable and graduated dip-rods are suitable for use with any inner can and therefore do not require individual calibration. Since neither of these points is of importance to private individuals or organisations using only a few gauges the less costly commercial patterns are offered. In these the cylindrical parts and the inner cans are usually made from soldered sheet metal which, from the functional point of view, gives a perfectly serviceable gauge but without the advantages mentioned above.



## RAIN GAUGES

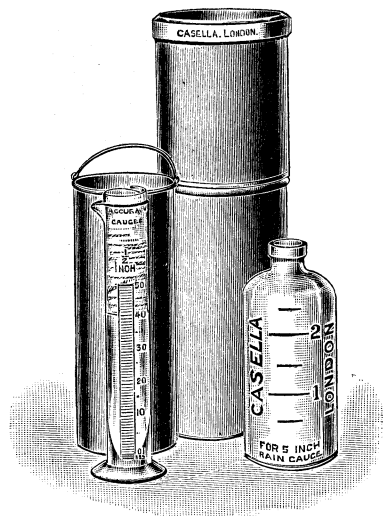

**The Snowdon Pattern Rain Gauge** is used for taking daily measurements of rainfall. The cylindrical top portion is provided with an accurately turned and bevelled brass rim of 5 inches (127 mm) diameter, and is designed to minimize the loss of rain caused by splashing from the funnel. This funnel leads down to a glass inner bottle placed either in an inner can or in the base itself.

Inside the base of the "Insulated pattern" (W 5010/2) there is a rim on which the top edge of the inner can rests, thus forming an insulating space between the outer wall of the gauge and the inner bottle. In this way the risk of rain freezing in winter or evaporating in summer is considerably reduced. The inner bottle supplied with each gauge has an approximate capacity of 3 inches (75 mm) while the inner can will take a further 2½ inches (63 mm) in the event of overflow.

*A graduated glass measuring jar is essential for use with this gauge. Customers are asked to order one of these from the choice given on pages 87 and 88.*

- W 5000 **Snowdon Rain Gauge**, British Meteorological Office pattern, brazed copper tube case, with inner can and glass bottle
- W 5002 **Snowdon Rain Gauge**, commercial pattern, soldered copper sheet case, with inner can and glass bottle
- W 5004 **Ditto**, but without inner can
- W 5006 **Snowdon Rain Gauge**, commercial pattern, soldered galvanized iron case, with inner can and glass bottle
- W 5008 **Ditto**, but without inner can
- W 5010 **Snowdon Rain Gauge**, Insulated pattern, soldered copper sheet case, with inner can and glass bottle
- W 5012 **Ditto**, but with soldered galvanized iron case
- W 5014 **Meteorological Office Certificate**  
18 × 5½ in dia    45.7 × 14 cm dia    6 lb 2.7 kg

*Please read introduction to understand difference between BMO and commercial pattern raingauges*

## RAIN GAUGES

**The 5-inch Splayed-base Rain Gauge**, with a 5 inch (127 mm) diameter brass rim, is similar in construction and design to the non-insulated Snowdon rain gauges described on the previous page except for the base of the case which is splayed out to give the instrument greater stability when on site. It is used for daily measurements of rainfall and each gauge is supplied with an inner can and glass inner bottle. The difference between the BMO and commercial patterns will be appreciated after reading the introduction to this section.

*A graduated glass measuring jar is essential for use with this gauge. Customers are asked to order one of these from the choice given on pages 87 and 88*

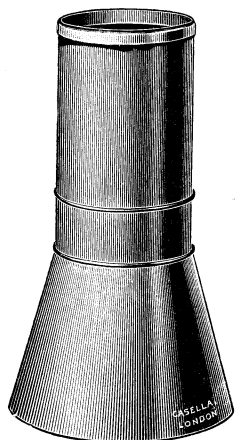

**W 5050 5-inch Splayed-base Rain Gauge**, British Meteorological Office pattern Mk. II, copper case

**W 5052 Ditto**, commercial pattern, copper case

**W 5054 Ditto**, commercial pattern, galvanized iron case

**W 5014 Meteorological Office Certificate**

$19\frac{1}{4} \times 8\frac{1}{2}$  in dia     $49 \times 21.6$  cm dia     $6\frac{1}{2}$  lb    2.9 kg

**The Howard Rain Gauge** illustrated is a simple, inexpensive instrument. Although not suitable for taking official records it is sufficiently well made to permit a reasonably accurate measurement of rainfall to be made with a small financial outlay. The brass rim fitted to the funnel has a diameter of 5 inches (127 mm) and is accurately turned and bevelled. The glass receiving bottle has a capacity of 3 inches or 75 millimetres.

*A graduated glass measuring jar is essential for use with this gauge. Customers are asked to order one of these from the choice given on pages 87 and 88*



**W 5100 Howard Rain Gauge**, with glass receiving bottle graduated every 0.5 in of rain

**W 5102 Ditto**, with glass receiving bottle graduated every 10 mm of rain

$14\frac{1}{2} \times 5\frac{1}{4}$  in dia     $36.8 \times 13.3$  cm dia    2 lb 0.9 kg

For spare receiving bottles see W 5340 or W 5342, p 88



## RAIN GAUGES

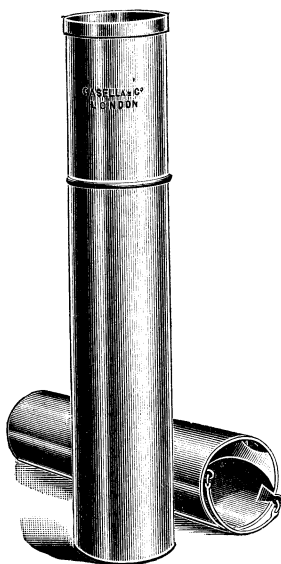

The **Bradford Rain Gauge** is designed for use in isolated regions where measurements can only be taken at weekly or monthly intervals. It has a larger capacity and is more robustly constructed than the daily gauges previously described. It is provided with a 5 inch (127 mm) diameter brass rim and is so designed that the minimum loss is caused through evaporation. The amount of rain received is first measured by means of a graduated one-piece dip-rod and then more accurately by means of a glass measuring jar.

*Both a graduated glass measuring jar and a graduated dip-rod are essential for use with this gauge. For details of the former see pp 87 and 88 and for the latter see below. Each gauge is supplied with an inner can*

- W 5150 **Bradford Rain Gauge**, British Meteorological Office pattern Mk. IV, copper tube case, capacity 15 in (380 mm)
  - W 5152 **Bradford Rain Gauge**, British Meteorological Office pattern Mk. II, sheet copper case, capacity 27 in (680 mm)
  - W 5154 **Bradford Rain Gauge**, commercial pattern, sheet copper case, capacity 15 in (380 mm)
  - W 5156 **Bradford Rain Gauge**, commercial pattern, galvanized iron case, capacity 15 in (380 mm)
  - W 5158 **Ditto**, capacity 27 in (680 mm)
  - W 5160 **Graduated Dip-rod**, divided every 0.1 in of rain for a 15 in gauge
  - W 5162 **Ditto**, divided every 5 mm of rain for a 380 mm gauge ✓✓
  - W 5164 **Ditto**, divided every 0.1 in of rain for a 27 in gauge
  - W 5166 **Ditto**, divided every 5 mm of rain for a 680 mm gauge
  - W 5168 **Meteorological Office Certificate**, for gauge and dip-rod
- 15 in (380 mm) gauge  $25\frac{3}{4} \times 5\frac{1}{2}$  in dia 65 x 14 cm dia 9 lb 4.0 kg

381 mm



## RAIN GAUGES

The **Octapent Rain Gauge** is designed for use in isolated regions where measurements can only be taken at weekly or monthly intervals. The top portion is provided with a 5 inch (127 mm) diameter brass rim and is expanded to fit on to a base of 8 inch (203 mm) diameter, thus permitting a larger capacity without unduly increasing the height. It is so designed that the minimum loss is caused by evaporation, while provision is made in the inner can to insert a frost protector, thus making it suitable for exposure in mountainous areas. The frost protector, consists of a length of rubber tubing, weighted and closed at one end. By slightly collapsing under pressure this device prevents damage being caused to the inner can when the rain water freezes and expands. The protector must always be removed before taking measurements with the one-piece graduated dip-rod.



Both a graduated glass measuring jar and a graduated dip-rod are essential for use with this gauge. For details of the former see pp 87 and 88 and for the latter see below. Frost Protectors are offered as an optional extra

- W 5200 **Octapent Rain Gauge**, British Meteorological Office pattern Mk. IIA, copper case, capacity 27 in (680 mm) ≡ 686 mm
- W 5202 **Octapent Rain Gauge**, British Meteorological Office pattern Mk. IIB, copper case, capacity 50 in (1270 mm)
- W 5204 **Octapent Rain Gauge**, commercial pattern, copper case, capacity 27 in (680 mm)
- W 5206 **Ditto**, capacity 50 in (1270 mm)
- W 5208 **Frost Protector**, for use with 27 in (680 mm) gauge
- W 5210 **Ditto**, for use with 50 in (1270 mm) gauge
- W 5212 **Graduated Dip-rod**, divided every 0.5 in of rain for a 27 in gauge
- W 5214 **Ditto**, divided every 10 mm of rain for a 680 mm gauge ✓✓
- W 5216 **Ditto**, divided every 0.5 in of rain for a 50 in gauge
- W 5218 **Ditto**, divided every 10 mm of rain for a 1270 mm gauge
- W 5220 **Meteorological Office Certificate**, for gauge and dip-rod

27 in (680 mm) gauge 27 × 13 in dia 68 × 33 cm dia 12½ lb 5.7 kg



## RAIN GAUGES

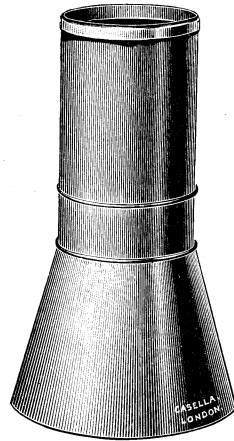
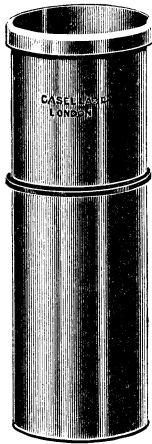

Whereas the gauges described on the previous pages have 5 inch (127 mm) diameter brass rims those listed on this page are fitted with rims of 8 inches (203 mm) diameter to meet the preference of some observers in this country and overseas. As with the 5-inch gauges these also have deep set funnels to minimize loss through splashing and it has been proved in practice that the amount of rain measured by the two gauges under identical conditions is the same. The inner bottle supplied with each gauge has an approximate capacity of 3 inches (75 mm), while the inner can will take a further  $4\frac{1}{2}$  inches (104 mm) in the event of overflow. Although normally used for daily measurements they are sometimes used to take measurements at weekly intervals.

*A graduated glass measuring jar is essential for use with this gauge. Customers are asked to order one of these from the choice given on p 88*

- W 5250 **8-inch Rain Gauge**, cylindrical copper case, with inner can and inner bottle
- W 5252 **Ditto**, galvanized iron case  
22×8½ in dia. 56×21.6 cm dia 11 lb 5.0 kg
- W 5254 **8-inch Rain Gauge**, copper case, splayed-base, with inner can and inner bottle
- W 5256 **Ditto**, galvanized iron case  
24×14 in dia 60×36 cm dia 12 lb 5.4 kg
- W 5258 **Meteorological Office Certificate**



## MEASURING JARS FOR RAIN GAUGES

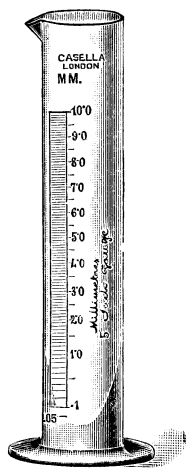

Camden Pattern  
W 5302



Tapered-base Pattern  
W 5304

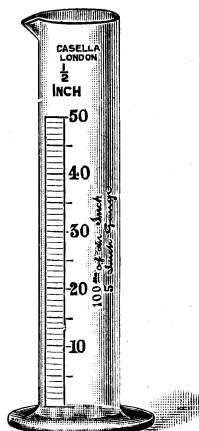

Flat-base Pattern  
W 5308

These jars are used for measuring the amount of rain received in a rain gauge. They are made of glass in various sizes depending on the capacity of the gauge with which they are to be used. Each jar is graduated to indicate directly the amount of rain which has fallen; hence the capacity mentioned below against each type is in terms of rainfall. Of the three patterns illustrated the two tapered inside at the base are to be preferred since these permit a small amount, or "trace," of rain to be measured more accurately than with the flat base pattern.

### Jars for use with 5 inch (127 mm) diameter gauges

#### Camden Pattern

W 5300 Capacity 0.5 in graduated every 0.01 in with mark for 0.005 in added at base

W 5302 Capacity 10 mm graduated every 0.1 mm with mark for 0.05 mm added at base

10 × 3 in dia 25 × 7.6 cm dia 10 oz 283 g

#### Tapered-base Pattern

W 5304 Capacity 0.5 in graduated every 0.01 in with mark for 0.005 in added at base

W 5306 Capacity 10 mm graduated every 0.1 mm with mark for 0.05 mm added at base

11 × 1 $\frac{3}{4}$  in dia 28 × 44 cm dia 4 oz 115 g





## MEASURING JARS FOR RAIN GAUGES

Jars for use with 5 inch (127 mm) diameter gauges (*continued*)

### Flat-base Pattern

- W 5308 Capacity 0.5 in graduated every 0.01 in
- W 5310 Capacity 10 mm graduated every 0.1 mm  
8×3 in dia 20×7.6 cm dia 6 oz 170 g
- W 5312 Capacity 1.0 in graduated every 0.05 in
- W 5314 Capacity 25 mm graduated every 0.5 mm  
10×3½ in dia 25×9 cm dia 9 oz 255 g
- W 5316 Capacity 2.0 in graduated every 0.05 in
- W 5318 Capacity 50 mm graduated every 0.5 mm  
15×4 in dia 38×10 cm dia 14 oz 397 g

Jars for use with 8 inch (203 mm) diameter gauges

### Tapered-base Pattern

- W 5320 Capacity 0.5 in graduated every 0.01 in with mark for 0.005 in added at base
- W 5322 Capacity 10 mm graduated every 0.1 mm with mark for 0.05 mm added at base  
12×2½ in dia 30.4×6.3 cm dia 7 oz 198 g

### Flat-base Pattern

- W 5324 Capacity 0.5 in graduated every 0.01 in
- W 5326 Capacity 10 mm graduated every 0.1 mm  
10½×3½ in dia 26.7×9 cm dia 12 oz 340 g
- W 5330 **Meteorological Office Certificate** for any of the jars mentioned on this and the previous page

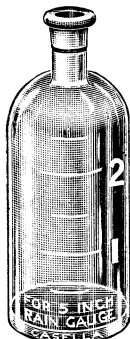

### INNER BOTTLES

For use with Snowdon or 5-inch Splayed-base Rain Gauges

- W 5340 Capacity 3 in, graduated every 0.5 in
- W 5342 Capacity 75 mm, graduated every 10 mm

For use with 8-inch Rain Gauges

- W 5344 Capacity 3 in, graduated every 0.5 in
- W 5346 Capacity 75 mm, graduated every 10 mm



## RECORDING RAIN GAUGES



### NATURAL SIPHON RAINFALL RECORDER

This instrument has enjoyed great popularity for many years among Meteorological Offices, Public Authorities, River Catchment Boards, Agricultural Stations, Drainage Departments and private individuals all over the world. It employs a natural siphon action which is free from the defects commonly found in some other types of siphoning recorders. There are no moving parts other than the float and, therefore, there is nothing delicate to adjust.

The rain is received in the usual manner in a deep-set funnel to which is soldered an accurately turned and bevelled brass rim. It then passes down into a chamber containing a float to which is attached an upright rod carrying a pen which records the vertical motion of the float on a chart fitted round a drum rotated by a spring driven clock. As the float chamber fills and the float rises a side connecting tube also fills until the water level reaches the top open end of a second tube concentric to the first. The top of this second tube terminates a short distance from a glass disc closing the top of the outer tube, thus forming a gap of almost capillary dimensions but with a large total area since the diameter of the inner tube is large compared to the gap itself. When this gap is filled siphoning down the inner tube commences suddenly and is completed 12 to 15 seconds later. The cut-off point is accurately controlled by a sharp edged vee-shaped hole where the outer tube enters the float chamber. This arrangement ensures that the amount of water which siphons out of the chamber is automatically and accurately measured. It also ensures that provided the chamber and siphoning tubes are kept clean no "dribbling" will occur. A filter is incorporated to ensure that no dirt enters the chamber with the rain.



## NATURAL SIPHON RAINFALL RECORDER

(continued)

The range of rainfall intensity met in different parts of the world makes it necessary for recorders with different frequencies of siphoning to be available if the record on the chart is to be easily read. The control of the frequency of siphoning for a given rainfall intensity is obtained by varying the diameter of the brass rim fitted to the top portion of the instrument. Our experience has shown that three rim sizes best meet the requirements of meteorologists throughout the world. These sizes together with their resultant frequency of siphoning are as follows:—

- 8 inch (203 mm) diameter rim siphons every 0.4 in or 10 mm of rain
- 5.058 inch (128.5 mm) diameter rim siphons every 1.0 in or 25 mm of rain
- 3.237 inch (82.2 mm) diameter rim siphons every 2.5 in or 62 mm of rain

As a guide to assist customers to decide which size of rim will best suit their requirements we give below the approximate maximum rates of rainfall which are easily distinguishable on daily or weekly charts.

Weekly chart, 8 in (203 mm) rim	0.7 in or 18 mm per hour
Weekly chart, 5.058 in (128.5 mm) rim	1.8 in or 45 mm per hour
Weekly chart, 3.237 in (82.2 mm) rim	4.5 in or 112 mm per hour
Daily chart, 8 in (203 mm) rim	5.0 in or 127 mm per hour
Daily chart, 5.058 in (128.5 mm) rim	12.6 in or 315 mm per hour
Daily chart, 3.237 in (82.2 mm) rim	32.0 in or 785 mm per hour

In some tropical climates the very high rainfall intensities are only experienced during relatively few months of the year, while during the remaining months the rainfall may be slight. If an instrument fitted with a rim suitable for the high intensity period is used throughout the year the recordings made during the low intensity months will be excessively open. To meet this problem we offer "conversion rims" which, with the corresponding daily or weekly charts, can be fitted at the beginning of the rainy season. Details of these will be found on the following page.



## NATURAL SIPHON RAINFALL RECORDER

(continued)

**Natural Siphon Rainfall Recorders**, each complete with 55 charts and one bottle of ink

### Recorders with 8 inch (203 mm) diameter rims

Case	Window	Charts for recording in inches		Charts for recording in millimetres	
		Daily	Weekly	Daily	Weekly
		No. 395	No. 377	No. 512	No. 376
Galvanized Iron	fixed	W 5350	W 5352	W 5354	W 5356
Copper	fixed	W 5360	W 5362	W 5364	W 5366
Copper	hinged	W 5370	W 5372	W 5374	W 5376

### Recorders with 5.058 inch (128.5 mm) diameter rims

Case	Window	Daily		Weekly	
		No. 435	No. 467	No. 278	No. 330
		Galvanized Iron	fixed	W 5380	W 5382
Copper	fixed	W 5390	W 5392	W 5394	W 5396
Copper	hinged	W 5400	W 5402	W 5404	W 5406

### Recorders with 3.237 inch (82.2 mm) diameter rims

Case	Window	Daily		Weekly	
		No. 601	No. 602	No. 603	No. 604
		Galvanized Iron	fixed	W 5410	W 5412
Copper	fixed	W 5420	W 5422	W 5424	W 5426
Copper	hinged	W 5430	W 5432	W 5434	W 5436

25×12 in dia 63.5×30.5 cm dia 18 lb 8.2 kg

W 5440 **Meteorological Office Certificate** for any of the above recorders

### Spare Parts and Accessories

- W 5442 **Conversion Rim**, 5.058 in (128.5 mm) diameter, to fit over 8 in (203 mm) rim
- W 5444 **Ditto**, 3.237 in (82.2 mm) diameter, to fit over 5.058 in (128.5 mm) rim
- W 5446 **Ditto**, 3.237 in (82.2 mm) dia, to fit over 8 in (203 mm) rim
- W 5448 **Transparent Template**, for determining the duration and rate of rainfall received in a recorder fitted with an 8 in (203 mm) diameter rim and a daily clock
- W 5450 **Ditto**, for similar recorder fitted with a weekly clock
- W 5452 **Ditto**, for recorder fitted with a 5.058 in (128.5 mm) diameter rim and a daily clock
- W 5454 **Ditto**, for similar recorder fitted with a weekly clock
- W 5456 **Extra charts**, 55
- W 5458 **Extra charts**, 100
- T 6566 **Bottle of Ink**
- W 5460 **Copper Float**, with pen rod and guide
- W 5462 **Pen**, with block to fit on to pen rod
- W 5464 **Anti-frost Safety Disc**, for bottom of float chamber
- W 5466 **Spare Clock**, daily
- W 5468 **Spare Clock**, weekly
- W 5470 **Change Wheels**, to convert weekly clock to daily
- W 5472 **Change Wheels**, to convert daily clock to weekly



## TILTING SIPHON RAINFALL RECORDER

British Meteorological Office Pattern

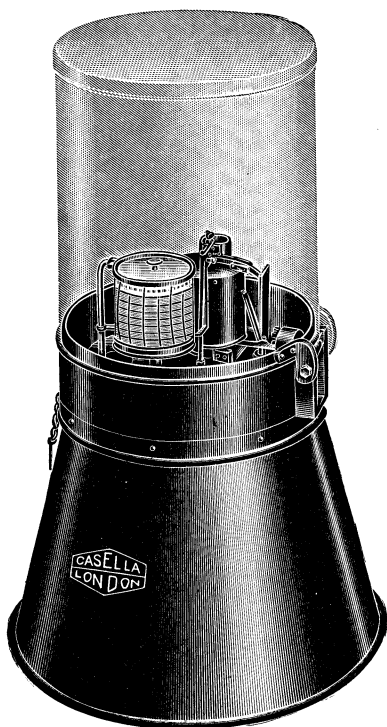

As with the Natural Siphon Rainfall Recorder described on previous pages the rain collected by this instrument is led down into a cylindrical vessel containing a light metal float, the vertical motion of which is recorded on a revolving clock-driven chart drum by means of a pen attached to a vertical rod extending from the top of the float itself. The chief difference between the two instruments lies in the method of emptying the float chamber once it has been filled. In this recorder the chamber is balanced on a knife edge and is maintained in an upright position by means of a trip mechanism which is automatically released when the float reaches a position in the chamber governed by the collection of 0.2 inch (5 mm) of rain in the temperate model or 1 inch (25 mm) in the tropical model. When the trip mechanism is released the pen is lifted off the chart and the chamber tilts, allowing the rain to siphon out of the siphon tube leading from its base. When the chamber is empty a counter weight restores it to its original position,



## TILTING SIPHON RAINFALL RECORDER

(continued)

the float slides to the bottom of the chamber and the pen returns to the chart on the zero line. This whole siphoning operation takes approximately 15 seconds for completion.

The recording mechanism described above is supported by a gun-metal base casting flanged to take the copper sheet splayed base and the copper top portion. This top portion has a receiving aperture defined by an accurately turned brass rim of 11.31 inches (287.3 mm) diameter for the temperate model or 5.058 inches (128.5 mm) for the tropical pattern. A hinged window gives access to the pen and chart when the instrument is in use. The top portion is hinged on to the base casting so that when tilted back the whole movement may be exposed. It is provided with a padlock for locking purposes.

W 5550 **Tilting Siphon Rainfall Recorder, Temperate pattern,** recording in inches, with 55 daily charts No. 326 and one bottle of ink

W 5552 **Ditto,** recording in millimetres, complete with 55 daily charts No. 345 and one bottle of ink

33×20 in dia 84×51 cm dia 79 lb 35.8 kg

W 5554 **Ditto, Tropical Pattern,** recording in inches, with white radiation shield to reduce evaporation errors, with 55 daily charts No. 570 and one bottle of ink

W 5556 **Ditto,** recording in millimetres, with 55 daily charts No. 571 and one bottle of ink

33×20 in dia 84×51 cm dia 74 lb 33.6 kg

W 5558 **Extra Charts, 100**

T 6566 **Bottle of Ink**

W 5560 **Spare Pen**

W 5562 **Spare Pen Arm**

W 6306 **Spare Clock, daily**

W 5566 **Spare Float,** with pen rod and guide

**Note.**—Instruments fitted with weekly charts will be supplied if specially requested but they are not normally recommended in view of the crowding together on the chart which would result



## JARDI RATE-OF-RAINFALL RECORDER

British Meteorological Office Pattern

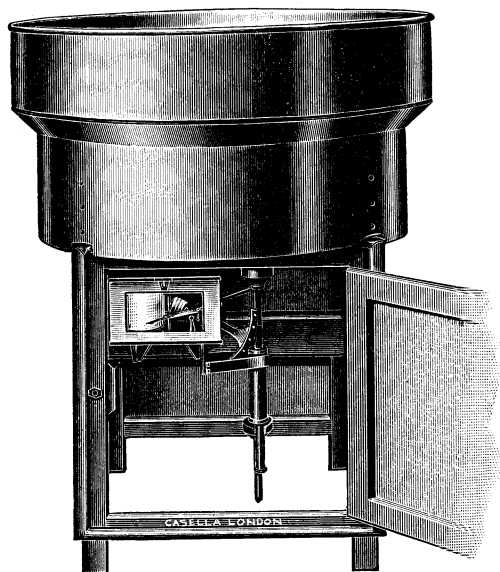

This instrument provides in record form information on the rate of rainfall which occurs during the 24-hour period covered by each chart. It does not record total rainfall. Knowledge of the rate of rainfall as opposed to total rainfall is essential when designing drainage systems for housing estates, airfields, plantations, etc., since unless this is known serious and costly errors may be made in provision for the disposal of flood water at maximum rates. An under estimation may well lead to flooding while over estimation will result in more costly installations being provided than in fact prove necessary. Either of these errors could lead to the wastage of much money.

The instrument is made to the design of the British Meteorological Office with subsequent modifications and improvements recommended by the Meteorological Office of Southern Rhodesia. In order to provide the necessary response and magnification required more rain has to be collected than in the case of other rainfall recorders described in this catalogue. The receiving aperture is therefore made much larger, its actual size, depending on the maximum rate likely to be met. The rain is led into a cylindrical metal float chamber from which it escapes through an orifice at the bottom into a second chamber. Inside the first chamber is a small float attached to the base of which is a tapered rod which projects downwards through the orifice into the second chamber. When no rain is falling this rod comes to rest on a stop which is adjusted so that the larger end of the rod does not quite close the orifice.



## JARDI RATE-OF-RAINFALL RECORDER

(continued)

Surrounding the second chamber up to the junction of the two chambers is an open topped dish with a sharp edge forming a weir. Water flows from the second chamber into this dish and by adjusting the float stop one can ensure that water only flows away over the weir when a certain rate of rainfall has been reached. This rate varies for each model and is as indicated below. The provision of the weir ensures that the float, tapered rod and orifice are always wet and the instrument is always ready to commence recording.

When rain falls the float rises and the water escapes from the annulus formed between the rod and the orifice until finally the rate of inflow balances the rate of outflow. At this point the recorder will trace a horizontal line on the chart wrapped round a clockwork drum, the trace corresponding to the rate of rainfall. As the float rises or falls so the pen traces a line recording its movement. When the rainfall ceases the pen returns to the bottom of the chart, only to rise again when rain recommences.

The funnel and top portion of the recorder are made of stout copper while the lower portion of the case enclosing the movement is a wood frame covered with asbestos sheeting.

- W 5600 **Jardi Rate-of-Rainfall Recorder**, range 10 to 160 mm per hour, 38 in (96.5 cm) diameter rim, with 100 charts No. 502/160 and one bottle of ink  
43 × 39 in dia 109 × 99 cm dia 168 lb 76 kg
- W 5602 **Ditto**, range 15 to 240 mm per hour, 31 in (78.75 cm) diameter rim, chart No. 502/240  
41 × 32 in dia 104 × 81 cm dia 140 lb 63 kg
- W 5604 **Ditto**, range 20 to 320 mm per hour, 27 in (68.6 cm) diameter rim, chart No. 502/320  
40 × 28 in dia 102 × 71 cm dia 120 lb 54 kg
- W 5606 **Ditto**, range 30 to 480 mm per hour, 22 in (55.9 cm) diameter rim, chart No. 502/480  
38 × 23 in dia 97 × 58.5 cm dia 95 lb 43 kg
- W 5608 **Extra charts**, 100
- T 6566 **Bottle of Ink**
- T 6570 **Spare Clock**, daily
- T 6586 **Spare Pen**
- T 9240 **Spare Pen Arm**
- W 5610 **Spare Float**, with tapered rod
- W 5612 **Spare Suspension Strip**



**CASELLA  
LONDON**

**95-DAY RAINFALL RECORDER**

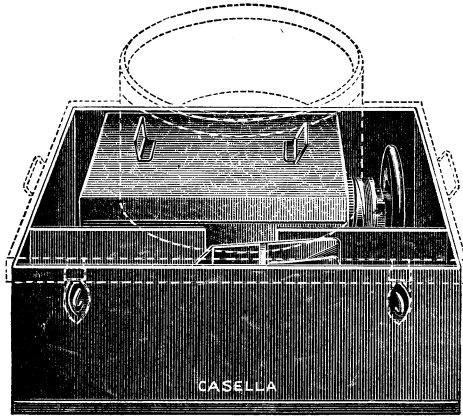
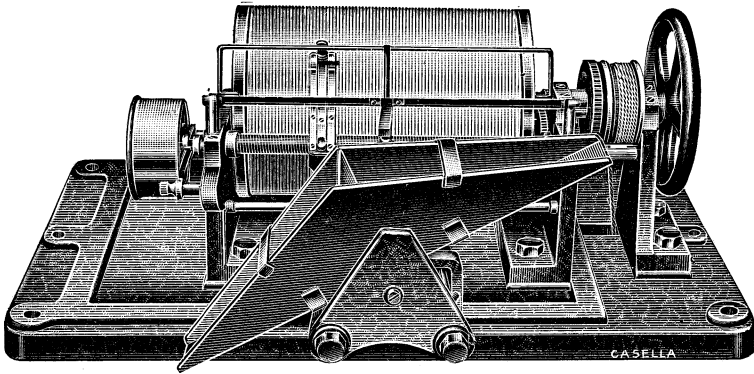



## 95-DAY RAINFALL RECORDER

(continued)

This instrument is designed to be left unattended in inaccessible places for long periods. It records continuously for 95 days on a chart wrapped round a drum 24 inches (60.8 cm) in circumference. The rain is received in a 16 inch (40.64 cm) diameter aperture and is then led into one or other side of a balanced bucket which tilts for every 0.1 inch or 2.5 millimetre of rain collected. Each tilt of the bucket actuates a sharp needle which pricks a small hole on the chart. This needle is carried on a nut which is advanced by the rotation of a screwed rod of 0.1 inch (2.54 mm) pitch. The drum and the screwed rod both rotate once every 24 hours, this rotation being actuated by a weight which has a fall of 54 inches (152 cm). The timing is controlled by a gear train incorporating a temperature compensated escapement. The chart thus has a time scale of 1 inch (25.4mm) per hour, permitting a rate of rainfall of up to 10 inches or 25 centimetres per hour to be determined. Damage to the needle is avoided by cutting into the drum a helix of the same pitch as that of the screw.

The whole gauge is so designed that it can be frozen up without damage and will start to record again when it thaws out. All steel parts are rust-proofed, and oil impregnated bearings are fitted so that high temperatures and humidities will not affect its performance. As far as possible the weight of individual parts has been kept to a minimum by the use of light alloys, the drive weights being split into units of 20 pounds (9 kg) each, so that transportation to difficult sites is rendered as easy as possible.

W 5650 **95-day Rainfall Recorder**, recording in inches, with inner case over drum and gearing ; outer case with two padlocks and keys, 5-year supply of charts No. 547

W 5652 **Ditto**, recording in millimetres

W 5654 **Extra Charts, 20**

32 × 25 × 25 in    82 × 63 × 63 cm    194 lb    88 kg



## ELECTRICAL RAINFALL RECORDER

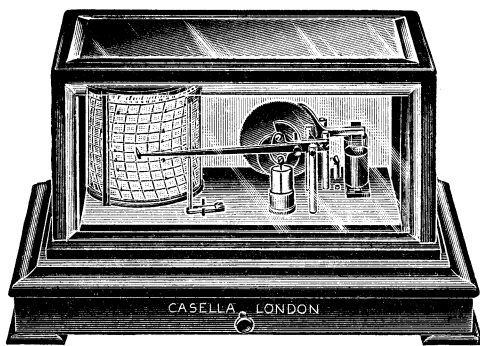

Recorder

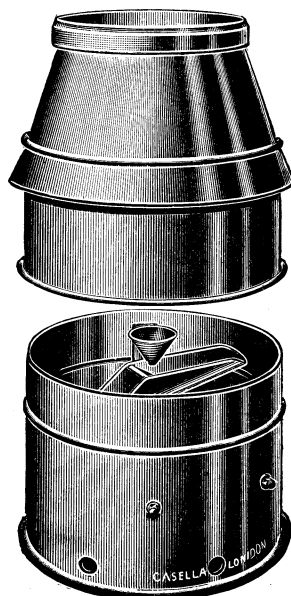

Receiver

This instrument is designed to record total rainfall at a distance from the rain receiver and so obviate the necessity of frequent outdoor visits for changing the chart. The recorder is housed in a mahogany and glass case similar to those used for our barograph (p 132, Cat. No. 808) and our recording anemometer (p 17 in this catalogue), so that any combination of these three instruments makes an attractive display in an office or a centre of interest in a public room.

The rain is received in an aperture defined by an 8 inch (203 mm) diameter brass rim ; it is then led down by a funnel into one half of a bucket. When this half is full it tilts and empties itself, at the same time allowing the other half of the bucket to fill until the process is repeated. Each tilt operates a mercury switch which closes a circuit to the recorder, causing a current to energize an electro-magnet which by means of a toothed wheel and escapement mechanism rotates a balanced cam. This cam raises the pen arm half a division on the chart for each tilt of the bucket, corresponding to 0.02 inches or 0.5 millimetres of rainfall. The pen reaches the top of the chart when the cam completes a rotation and after 2 inches or 50 millimetres of rain have fallen, then it returns to the base line. In practice it will be found that even with a weekly chart fitted the scale is sufficiently open to permit a maximum rate of 3 inches (76 mm) of rain to be distinguished.



## ELECTRICAL RAINFALL RECORDER

(continued)

When ordering an Electrical Rainfall Recorder customers are asked to state whether the instrument is required to operate off mains or batteries and if off mains to give us details of the current available so that the correct type of Mains Transformer-Rectifier can be supplied. If batteries are ordered the number supplied will depend upon the length of cable to be used. A Transformer-Rectifier or batteries, together with the required length of cable, must be included on each order since they are not included in items W 5700-W 5706.

W 5700 **Electrical Rainfall Recorder**, recording in inches, with 55 daily charts No. 506 and one bottle of ink

W 5702 **Ditto**, weekly charts No. 476

W 5704 **Ditto**, recording in millimetres, daily charts No. 340

W 5706 **Ditto**, weekly charts, No. 486

Recorder,  $15 \times 9\frac{1}{2} \times 9$  in  $38 \times 24 \times 23$  cm 14 lb 6.3 kg

Receiver,  $18 \times 12\frac{1}{2}$  in dia  $46 \times 31.8$  cm dia 13 lb 5.9 kg

W 1056 **Batteries**, suitable for length of cable to be used

W 1102 **Mains Transformer-Rectifier**, suitable for mains supply and length of cable to be used

W 1212 **2-core Cable**, per yard

W 5708 **Extra Charts**, 100

T 6566 **Bottle of Ink**

T 16908 **Spare Dittmar pen**

W 5710 **Spare Pen Arm**

T 6570 **Spare Recorder Clock**, daily

T 6574 **Spare Recorder Clock**, weekly

T 6578 **Set of Change Wheels**, to convert daily clock to weekly

T 6582 **Set of Change Wheels**, to convert weekly clock to daily

## DUVDEVANI DEW GAUGE

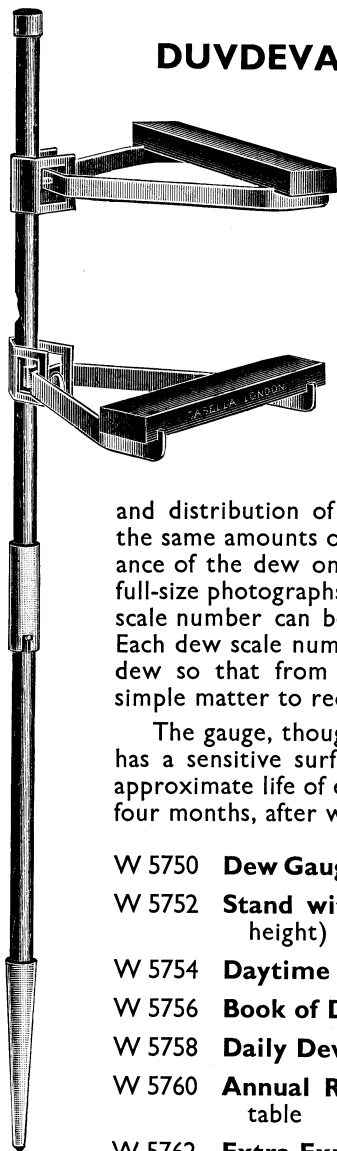

The Dew Gauge developed by Dr S. Duvdevani, Plant Ecologist at the Agricultural College, Pardess Hanna, Israel, consists of a carefully selected block of wood, specially treated and coated to ensure that dew measured on similar gauges in different parts of the world may be confidently and accurately compared. The gauge is exposed at about sunset at ground level or at any desired height and is then examined for dew formation at, or soon after, sunrise.

It has been found that the form, size and distribution of dew collected are always characteristic of the same amounts of dew. Hence by comparing the appearance of the dew on the gauge to a special set of calibrated full-size photographs of dew formed on a standard gauge a dew scale number can be assigned for the dew actually present. Each dew scale number has its equivalent in millimetres of dew so that from the table of equivalents provided it is a simple matter to record the amount of dew fallen.

The gauge, though simple in appearance and unbreakable, has a sensitive surface and must be carefully treated. The approximate life of each gauge when exposed nightly is about four months, after which it must be replaced.

- W 5750 **Dew Gauge** 12½ × 2 × 1 in. 32 × 5 × 2.5 cm
- W 5752 **Stand with one exposure bracket** (adjustable in height)
- W 5754 **Daytime Protecting Stand**
- W 5756 **Book of Dew Scale Standards**
- W 5758 **Daily Dew Register**, to last one month
- W 5760 **Annual Register**, with summary and equivalents table
- W 5762 **Extra Exposure Bracket**

Up to 4 dew gauges may be exposed at different heights on one stand. This should be taken into account when deciding the number of gauges and exposure brackets required

*A more detailed description of this equipment will be found in a separate publication which will be sent on request*

## PICHE EVAPORIMETER

The Piche Evaporimeter is designed to indicate in a simple and convenient manner the amount of evaporation which takes place from a wet paper surface. It is more often used in hot dry climates where knowledge of the rate of evaporation is of importance for the conservation of water. It consists of a cylindrical glass tube of 14 mm outside diameter, closed at one end and open at the other, graduated every 0.1 millilitres up to 30 ml. The open end of the tube is covered by a disc of filter paper of 30 mm diameter. This paper is kept in position by means of a brass ring and spring clip. The surface of the clip in contact with the paper is of the same diameter as the tube itself and is provided with a small central hole to enable the filter disc to be perforated if desired. The evaporating surface of the paper is 11 square centimetres.



The instrument is filled with distilled water, the paper and clip placed in position, and the whole inverted and suspended from the glass ring provided at the closed end. Both sides of the saturated paper protruding from the edges of the tube and clip thus form the evaporating surface. The alteration in level of the water in the tube indicates the amount of evaporation which takes place between consecutive readings. It is very sensitive to exposure and wind movement so that its use in a screen is recommended.

**W 5780 Piche Evaporimeter**, with metal clip and 200 paper discs

$12\frac{1}{2} \times \frac{1}{2}$  in dia 32 × 1.4 cm dia 2 oz 50 g

**W 5782 Extra Papers**, packet of 200

**W 5784 Suspension Stand**

**W 5786 Spare Metal Clip**

*If evaporimeters of different dimensions are required we shall be pleased to quote when given full information*



## EVAPORATION INDICATORS

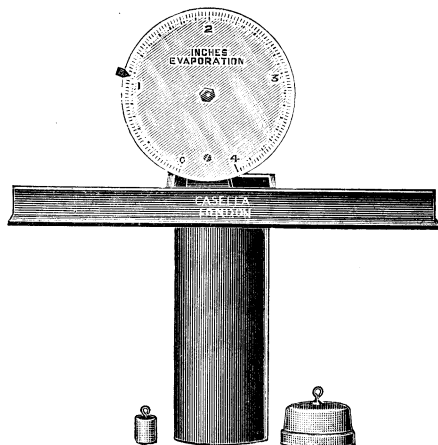

Knowledge of the evaporation taking place from the soil surface and from free water surfaces as well as the transpiration from plants is of importance to meteorologists, agricultural research workers and water engineers, particularly in hot climates. One method of obtaining this information is to measure the drop in level of a free water surface caused by evaporation.

The Evaporation Indicator is designed for use in a galvanized iron tank set into the ground and filled with water. It is mounted across one corner of the tank so that its scale faces outwards. A cylindrical still-well extends down into the water to break surface ripples. A float in the still-well is connected by a fine wire to a pulley mounted on a spindle carried on the main frame. The rotation of this pulley is indicated by a pointer moving across a scale divided from 0 to 4 in or 0 to 100 mm with subdivisions to 0.01 in or 0.2 mm. Thus the change in level of the water in the tank between consecutive readings can be measured and since the water surface area is known the rate of evaporation may be calculated, having taken into account any precipitation which may have occurred.

- W 5800 **Evaporation Indicator**, range 0 to 4 inches, with float and still-well
- W 5802 **Ditto**, range 0 to 100 millimetres  
20×21×7 in 51×53×18 cm 14 lb 6.35 kg
- W 5804 **Galvanized Iron Tank**, 72×72×24 inches
- W 5806 **Ditto**, 2×2×0.6 metres
- W 5808 **Spare Float**
- W 5810 **Spare Suspension Wire**

## EVAPORATION HOOK GAUGE

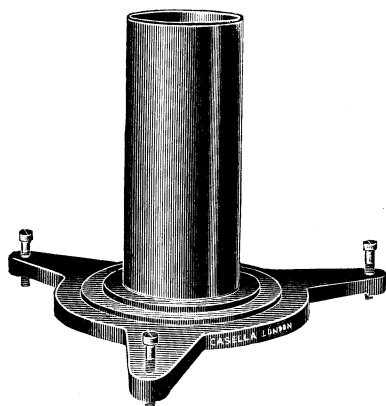

Still Well

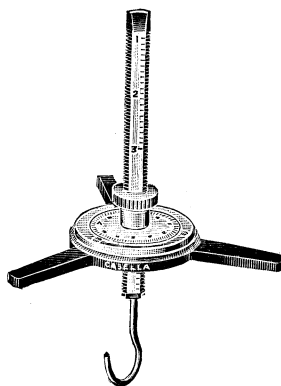

Hook Gauge

As with our Evaporation Indicator this instrument is designed for measuring the evaporation which takes place from the free water surface of a suitable form of tank or evaporation pan. It consists of the two parts illustrated. The Still Well provides an unruffled water surface for the hook gauge measurements. An opening in its base allows the water in the Still Well to maintain the same level as that in the tank. Three levelling screws fitted to the triangular base permit it to be accurately levelled. The Hook Gauge is designed to rest on the rim of the brass cylinder of the Still Well so that the hook is just immersed in the water. This hook may be raised or lowered by rotating a micrometer screw head, each complete turn of which alters the height of the hook by 0.1 in or 1 mm, while the micrometer head enables the height of the hook to be measured to within 0.002 in or 0.02 mm.

The change in level of the water is measured by taking the difference between consecutive readings of the group, usually every 24 hours, each reading being made by adjusting the height of the hook until its point just breaks the surface.

- W 5820 **Evaporation Hook Gauge**, range 4 in, reading by micrometer to 0.002 in, without Still Well
- W 5822 **Ditto**, range 10 cm, reading by micrometer to 0.02 mm
- W 5824 **Still Well**, for use with either of the above gauges
- W 5826 **Galvanized Iron Tank**, 48 in diameter  $\times$  10 in deep (122  $\times$  25.4 cm)
- |   |                                     |                            |
|---|-------------------------------------|----------------------------|
| Hook Gauge, $6\frac{1}{2} \times 4\frac{1}{2} \times 4\frac{1}{2}$ in | 16.5 $\times$ 11.5 $\times$ 11.5 cm | 1 $\frac{1}{2}$ lb 0.68 kg |
| Still Well, $8\frac{1}{2} \times 10 \times 10$ in                     | 21.5 $\times$ 25.4 $\times$ 25.4 cm | 4 lb 1.80 kg               |





## WATER FLOW METER

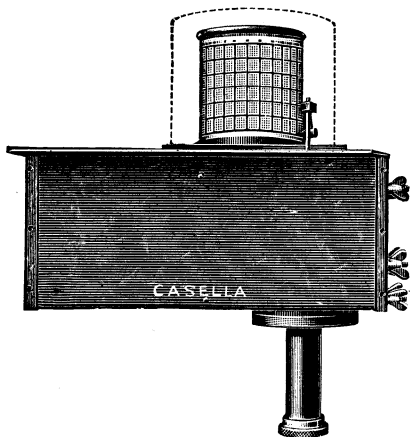

This is a simple, inexpensive instrument designed to measure the rate of flow of water from field drainage systems, small irrigation schemes, etc., without having to install elaborate layouts of a fixed type. It can be installed for as short or as long a period as required and is adaptable to record a wide range of flows.

The water flows into a settling chamber to remove silt and then through a strainer into the measuring chamber. When the instrument is delivered it will be found that the end of the

measuring chamber is closed by a removable ebonite plate which can then be drilled with suitable holes or made into a V notch weir or any other type to suit the rate of inflow anticipated.

Similarly if later a weir or perforated plate of different capacity is required it is a simple matter to replace the first by a second designed to meet the new conditions. The changes in level of the water in the measuring chamber cause a float in a still well to rise or fall, the amount being recorded directly on a chart wrapped round a clock driven drum. The pen which makes the trace is fitted to the pen-rod fixed to the top of the float. The recorder clock itself is mounted on a plate spanning the measuring chamber, and it is protected from the weather by a removable metal cover. Since the float is the only moving part the instrument may be left unattended, except for chart changing, for long periods without fear of anything going wrong.

- W 5850 **Water Flow Meter**, with 55 daily charts No. 436, one bottle of ink and three ebonite plates
- W 5852 **Ditto**, with weekly charts No. 530  
13½ × 10 × 5 in 34 × 25 × 38 cm 15 lb 6.8 kg
- W 5854 **Extra Charts**, 55
- W 5856 **Ditto**, 100
- T 6566 **Bottle of Ink**
- W 5462 **Pen**, with block to fit onto pen rod
- W 5858 **Float**, with pen rod and guide
- W 5860 **Ebonite Plate**, for forming weir

*If spare clocks or gear wheels to alter the clock timing from daily to weekly or vice versa are required their references will be found on page 98*



SECTION 6

SUNSHINE, SOLAR RADIATION AND CLOUD

CONTENTS

Table listing contents with page numbers: Sunshine Recorders, Campbell-Stokes, MO Pattern ... 106 & 107; Sunshine Recorders, Campbell-Stokes, Slate Base Pattern ... 108; Bimetallic Actinograph ... 110; Fineman Nephoscope ... 111; Besson Nephoscope ... 112; Universal Alidade, MO Mk II ... 112; Portable Alidade, MO Pattern ... 112; Clinometer Compass ... 112; Service Prismatic Compass ... 112

INTRODUCTION

THE measurement of sunshine duration, of total solar radiation and of cloud movement is standard procedure at most synoptic stations while sunshine duration is also measured at many climatological and health resort stations. The importance of the sunshine recorder will therefore be appreciated. The Campbell-Stokes Sunshine Recorder is used extensively by the British Meteorological Office in this country and by most Meteorological Offices throughout the British Commonwealth as well as in many other countries. It consists of a glass sphere mounted concentrically in a section of a spherical bowl, the diameter of which is such that the sun's rays are focused sharply on a card held in grooves cut into the bowl. There are three overlapping pairs of grooves each to take cards suitable in shape for different seasons of the year. The sphere and the bowl are made with great precision and the base on which they are mounted is so designed that the sphere is easily and accurately centred on the bowl. The cards used are subdivided into hourly intervals and figured every three hours. As the sun moves across the sky its focused image burns a trace on the card so that by measuring the trace at sunset the duration of sunshine may be accurately recorded.

The "cut" of the bowl varies according to the latitude in which the instrument is to be used but the instruments illustrated are so designed that if a country is intersected by one of the limits set two bowls may be supplied, one for each side of the latitude dividing line. It is then a simple matter for the user to change the bowl if the instrument is to be moved from one part of the country to another. A further advantage of our instrument is that in all models the glass sphere is securely clamped, thus making it impossible for birds or children to knock it off its support, with resultant loss of record and possible damage.

**SUNSHINE RECORDERS**

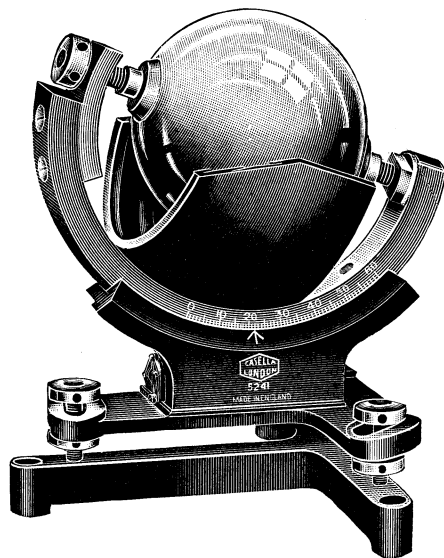

Tropical Mk IIIA

- W 6000 **Campbell-Stokes Sunshine Recorder, Tropical**, British Meteorological Office Pattern Mk IIIA, with levelling base and card clamping screw. For latitudes 0° to 40° North or South  
 $9\frac{1}{2} \times 7\frac{3}{4} \times 6\frac{1}{2}$  in     $24 \times 18.7 \times 16.5$  cm     $9\frac{1}{2}$  lb    4.3 kg
- W 6002 **Meteorological Office Certificate** for glass sphere
- W 6010 **One Year's Supply of Cards for above, Northern Hemisphere**, comprising :—  
 100 straight No. 490, for use from March 1st to April 11th and September 3rd to October 14th  
 150 long curved No. 491, for use from April 12th to September 2nd  
 150 short curved No. 492, for use from October 15th to February 28th
- W 6020 **One Year's Supply of Cards for above, Southern Hemisphere**, comprising :—  
 100 straight No. 525, for use from March 1st to April 11th and September 3rd to October 14th  
 150 long curved No. 526, for use from October 15th to February 28th  
 150 short curved No. 527, for use from April 12th to September 2nd
- W 6022 **Transparent Template** for measuring duration of sunshine



## SUNSHINE RECORDERS

(continued)

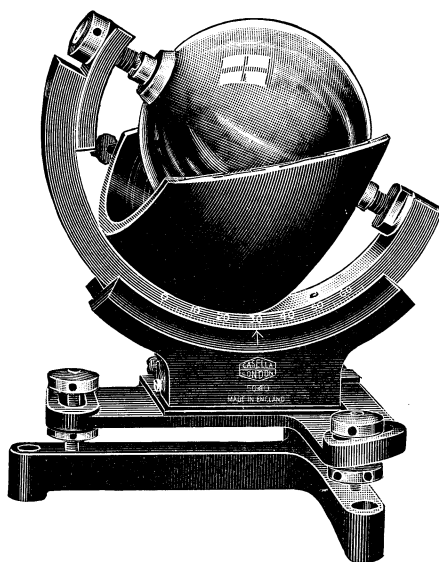

Sub-Tropical Mk IIIB

W 6050 **Campbell-Stokes Sunshine Recorder, Sub-Tropical**, British Meteorological Office Pattern Mk IIIB, with levelling base and card clamping screw. For latitudes 25° to 45° North or South

W 6100 **Campbell-Stokes Sunshine Recorder, Temperate, British** Meteorological Office Pattern Mk IIIC, with levelling base and card clamping screw. For latitudes 45° to 65° North or South

(The cut of bowl on this instrument is similar to that illustrated on p 108).

9½ × 7¾ × 6½ in    24 × 18.7 × 16.5 cm    9½ lb    4.3 kg

W 6002 **Meteorological Office Certificate** for glass sphere

W 6010 **One Year's Supply of Cards, Northern Hemisphere**

W 6020 **One Year's Supply of Cards, Southern Hemisphere**

W 6022 **Transparent Template** for measuring duration of sunshine

For details of cards supplied against W 6010 and W 6020 see p 106



## SUNSHINE RECORDERS

(continued)



Temperate (Mk IIIC bowl)

- W 6150 **Campbell-Stokes Sunshine Recorder, Tropical**, for latitudes  $0^{\circ}$  to  $40^{\circ}$  North or South, mounted on polished slate base
- W 6200 **Ditto, Sub-Tropical**, for latitudes  $25^{\circ}$  to  $45^{\circ}$  North or South
- W 6250 **Ditto, Temperate**, for latitudes  $45^{\circ}$  to  $65^{\circ}$  North or South  
 $8 \times 8 \times 8\frac{1}{2}$  in     $20.3 \times 20.3 \times 21.6$  cm    16 lb    7.26 kg
- W 6002 **Meteorological Office Certificate** for glass sphere
- W 6010 **One Year's Supply of Cards, Northern Hemisphere**
- W 6020 **One Year's Supply of Cards, Southern Hemisphere**
- W 6022 **Transparent Template**, for measuring duration of sunshine

*For details of cards supplied against W 6010 and W 6020 see p 106*

## BIMETALLIC ACTINOGRAPH

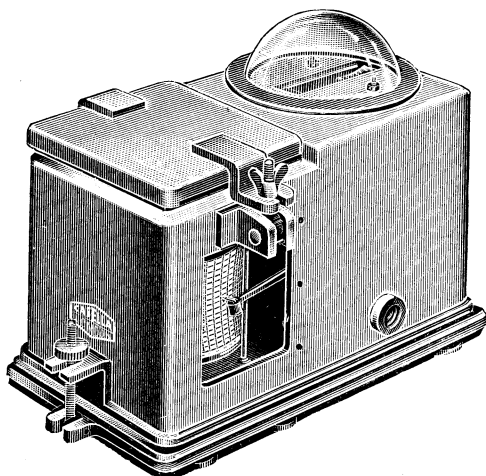

The Bimetallic Actinograph, designed by the British Meteorological Office, records the shortwave radiation received from the sun and sky on a horizontal surface.

The sensitive element consists of a blackened bimetallic strip mounted at one end on two shaded strips. The free end of the blackened strip records deflections proportional to the incident radiation. This recording is made on a standard daily rotation clock drum.

The combination of black and shaded strips provides compensation for ambient temperature changes. Further bimetallic strips provide compensation for changes of temperature.

The element is exposed to the radiation through a hemispherical glass dome mounted in the top of a white painted metal cover. The whole is made watertight by rubber gaskets and the inside is kept dry by a removable tube containing a drying agent.

W 6300 **Bimetallic Actinograph**, British Meteorological Office Pattern Mk 3, daily clock, complete with 100 charts No. 555 ranged 0 to 80 in arbitrary units, one bottle of ink and instructions

W 6302 **Extra Charts, No. 555**, 100

W 6304 **Spare Pen**

T 6566 **Bottle of Ink**

W 6306 **Spare Recorder Clock**, daily

$13\frac{1}{2} \times 7 \times 11$  in

$34.3 \times 17.5 \times 28$  cm

28 lb

12.7 kg



## NEPHOSCOPES

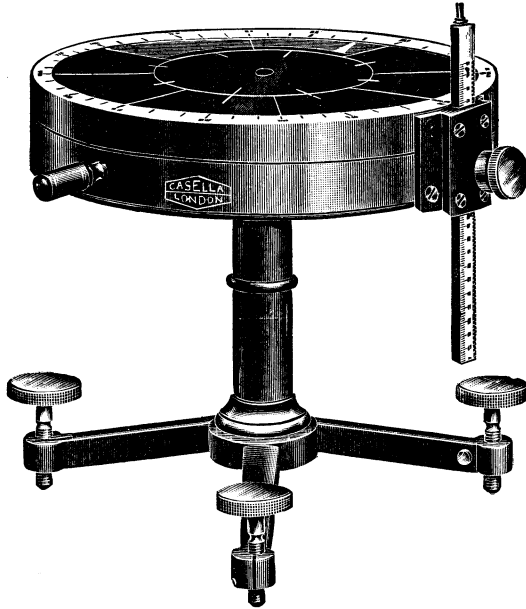

**The Fineman Nephoscope** illustrated above is made to a British Meteorological Office design. It consists of a circular mirror of black glass, bearing 2 concentric circles of 25 mm difference in radius, fitted in a circular brass mount engraved from 0° to 360°. Beneath the mirror the tip of a compass needle can be observed through a small clear section of the glass. A brass collar under the mirror mount bears an adjustable vertical pointer, the height of its tip above the mirror surface being measured in millimetres from a scale engraved on its supporting column. The mirror in its mount and the pointer on its collar can each be rotated independently about a common axis. The cloud direction is found by levelling and orientating the instrument so that the cloud image, the pointer and the mirror centre are in one line. The point at which the image leaves the circumference gives the direction. The velocity-height ratio is found from the time taken for the image to pass from one circle to the next.

W 6350 **Fineman Nephoscope**, British Meteorological Office pattern, complete with case which also acts as a supporting base

$9\frac{1}{2} \times 8 \times 7$  in     $24 \times 20 \times 17.5$  cm    9 lb    4 kg

## NEPHOSCOPES

(continued)

### BESSON COMB NEPHOSCOPE

for direct vision

This instrument is made to a British Meteorological Office design. It consists of a metal comb 36 in. (91.5 cm) long, carrying 7 vertical spikes. The comb is mounted on a 7 ft 6 in (2.28 m) high vertical rod carried by supporting brackets on a galvanised iron pillar. The rod and comb are free to rotate about a vertical axis. A conical direction plate, divided from 0° to 360°, and mounted on the rod enables the user to note the direction in which the comb is pointing by reference to a vertical indicating strip.

To find the velocity-height ratio of a cloud the observer adjusts his position and

that of the comb until the cloud appears to move along the tips of the spikes in the direction of the arrow attached to the comb. The time for the cloud to appear to move from one spike to the next is measured and the velocity-height ratio calculated from the constants of the instrument and time recorded. At the same time the direction of cloud movement may be read off the scale on the direction plate, assuming, of course, that the instrument has been correctly set up initially.

W 6400

**Besson Comb Nephoscope**, British Meteorological Office pattern, complete with supporting galvanised iron pillar

28 lb 12.7 kg

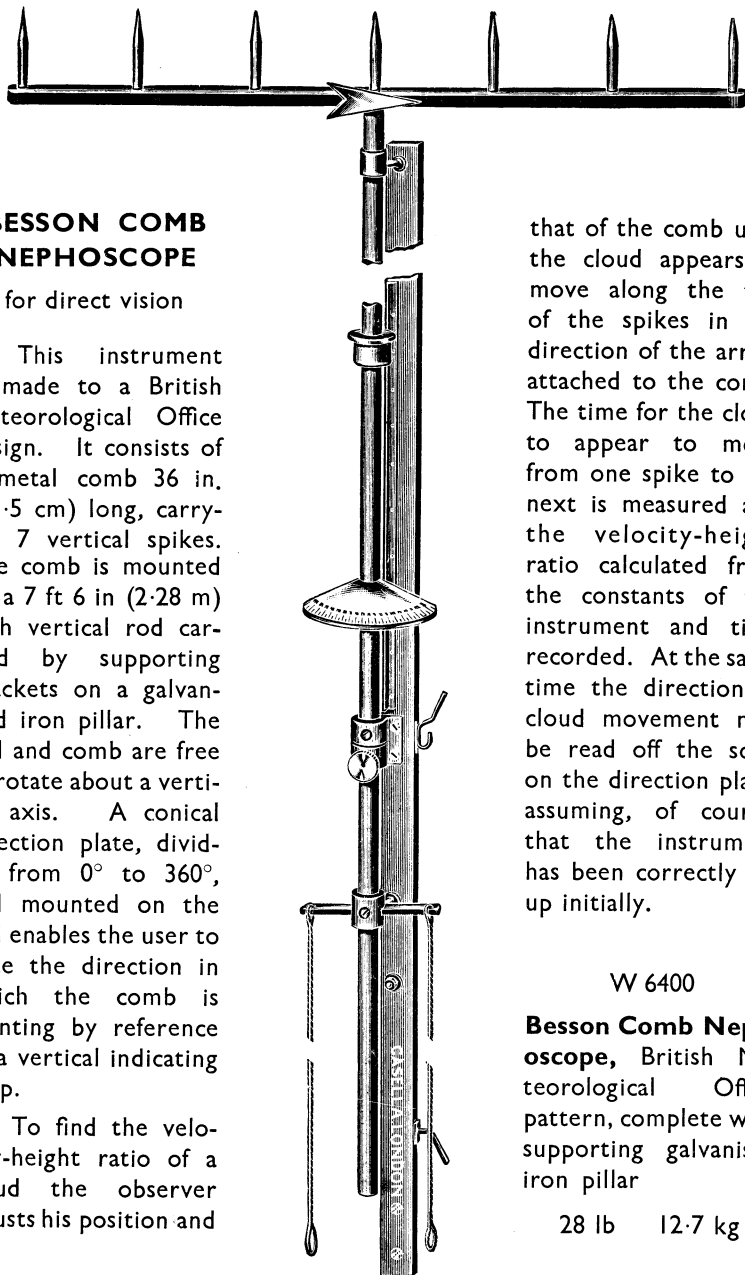



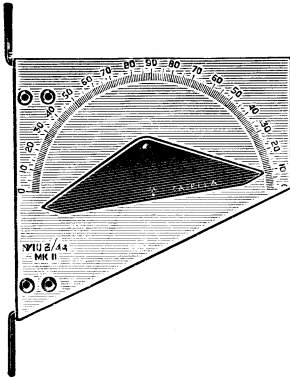

Universal Alidade Mk II

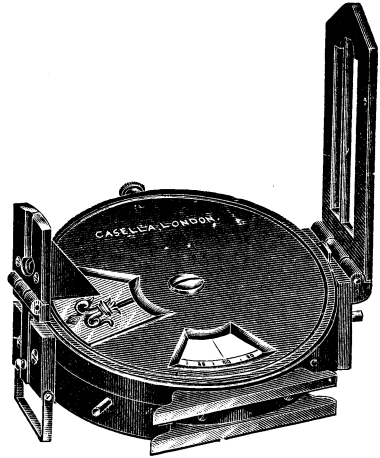

Clinometer Compass

- W 6450 **Universal Alidade**, British Meteorological Office Pattern Mk II, for use in conjunction with a cloud searchlight for measuring cloud heights. The brass sight bar is mounted on a brass plate so that it can rotate about an axis perpendicular to the plane of the plate. The angle of elevation of the cloud spot is indicated by the pointed end of the sight bar on the engraved scale on the plate.
- W 6460 **Portable Alidade**, British Meteorological Office pattern, for use in conjunction with a portable cloud searchlight when a permanent installation is inconvenient or impossible. This consists of a sight bar carrying a circular plate revolving about an axis perpendicular to the sight bar. The elevation scale is graduated directly in cloud height in feet.
- W 6470 **Clinometer Compass**, British Meteorological Office pattern, for observations of azimuth, of elevation and of the slope of plane surfaces as well as for the measurement of differences in height. This instrument is essentially a combined clinometer (for measuring angular elevations) and prismatic compass (for measuring azimuths with reference to magnetic north). It is supplied complete with leather case.
- W 6480 **Service Prismatic Compass, Dry Card, Mk IX**, 2 in. (50 cm) diameter dial, radium painted points, index line on bezel, divided scale on outer case, complete in leather sling case.
- W 6490 **Ditto, Liquid Pattern, Mk II**. In this pattern the liquid used to damp the oscillation of the card is glycerine, thus making it suitable for use in the tropics.



## METEOROLOGICAL REGISTERS AND CHARTS

- W 3818 **Pad of 12 Monthly Forms**, for recording pressure, humidity, temperature, rainfall, windspeed, wind direction and sunshine duration Form 790 Casella
- W 5980 **Daily Rainfall Register for 1 year, in inches** Form 1090 HMSO
- W 5982 **Ditto, in millimetres** Form 1091 HMSO
- W 5984 **Meteorological Diagram Register for 1 year** Form 1121 HMSO
- W 5986 **Pocket Rain Register for 1 year** Form 1122 HMSO
- W 5988 **Meteorological Register for 1 year** Form 1123 HMSO
- W 5990 **Outline Chart for Plotting Weather in British Isles** Form 2216 Scale 1 : 5,000,000 HMSO
- W 5992 **Ditto, for British Isles and North-Western Europe** Form 2217 Scale 1 : 5,000,000 HMSO
- W 5994 **Tephigram of Aerological Observations** Form 2810 HMSO
- W 5996 **Diagram to show Daily Values of Sunshine, Winds, Pressure, Temperature, Rainfall and Weather for 1 week** Form 3096 HMSO

## HUMIDITY AND BAROMETRIC TABLES

- T 8556 **Hygrometric Tables for use with non-ventilated Fahrenheit Thermometers** MO 265, for obtaining the relative humidity, vapour pressure and dew point pp 45 HMSO
- T 8728 **Ditto, but for use with Ventilated Wet-and-Dry Bulb Fahrenheit Thermometers** by Marvin, C. F. pp 87 Washington, USA : Govt. Printing Office
- T 8560 **Hygrometric Tables for use with Non-ventilated Celsius Thermometers**, single sheet only Casella
- T 8732 **Ditto**, but for use with Ventilated Thermometers, single sheet only Casella
- W 5998 **Barometer Conventions and Tables** British Standard No 2520 : 1954, pp 49 British Standards Institution



## METEOROLOGICAL PUBLICATIONS

### JOURNALS

- Quarterly Journal of the Royal Meteorological Society,**  
pp 140 approx London : Royal Meteorological Society £1 5 0
- Weather** pp 32 approx monthly London : Royal Meteorological Society Obtainable from any bookseller or agent 2 0
- Meteorological Magazine** pp 32 approx monthly HMSO 2 6
- Daily Weather Report** pp 4 HMSO Subscription rate on application to HMSO
- WMO Bulletin** pp 40 approx quarterly Geneva :  
World Meteorological Organisation published in English  
and French ... .. Sw. frs 1.

### HANDBOOKS AND TEXTBOOKS PUBLISHED BY HMSO

- Cloud Atlas for Aviators** MO 450 ... .. 2 6
- Cloud Card for Observers** Form 2335 Illustrating types of cloud reported in aviation and synoptic meteorological reports ... .. 6 0
- Cloud Forms according to the International Classification** MO 233 Including definitions, descriptions and photographs of clouds ... .. 2 6
- Handbook of Meteorological Instruments, Part I** MO 577 pp 458 1956 Describing instruments for surface observations ... .. £2 5 0
- Observer's Handbook** MO 554 pp 221 2nd ed. 1956 Instructions in the exposure of instruments and the making of weather observations at all types of stations ... 1 1 0
- Meteorological Glossary** MO 225 ii ... .. 15 0
- Meteorology for Aviators** by Sutcliffe, R. C. MO 432 ... 10 0
- Weather Map** MO 595 4th ed. 1956 An introduction to weather forecasting ... .. 12 6



## METEOROLOGICAL PUBLICATIONS

(continued)

### TEXTBOOKS BY OTHER PUBLISHERS

- The Weather** by Kimble, G. pp 256 Pelican Books A124  
Harmondsworth (Penguin Books) 1951 ... .. 3 0
- Techniques of Observing the Weather**, by Haynes, B. C.  
pp 272 London : Chapman and Hall 1947 ... .. £2 0 0
- Weather Analysis and Forecasting**, by Pettersen, S.  
London : McGraw-Hill 1956
- Vol. 1 Motion and motion systems pp 428 ... 3 4 0
- Vol. 2 Weather and weather systems pp 266 ... 2 5 0
- Introduction to dynamic meteorology**, by Panofsky, H.  
pp 243 Pennsylvania : State University 1956 Price not known
- Physical and dynamical Meteorology**, by Brunt, D. pp  
428 London : Cambridge University Press 2nd ed.  
1939 ... .. 1 5 0
- Handbook of Meteorology**, by Berry, F. A., Bolla, E., and  
Beers, N. R. pp 1068 London : McGraw-Hill 1945 2 5 0
- Meteorological Instruments**, by Middleton, W. E. K. and  
Spilhaus, A. F. pp 286 Toronto : University Press  
3rd ed. 1953 ... .. 4 12 0
- Guide to International Meteorological Instrument and  
Observing Practice** (Former IMO Publication No. 78,  
being completed by the WMO), 1954 Published in English  
and French by World Meteorological Organisation,  
Geneva ... .. Sw frs. 11.-

*To the best of our knowledge the prices shown were those ruling when this catalogue was published. They are given for guidance only and should be verified with the publishers.*



# FAHRENHEIT TO CELSIUS CONVERSION TABLE

CONVERSION FORMULA  $t^{\circ}\text{F.} = \frac{5}{9} (t-32)^{\circ}\text{C.}$

F.	C.	F.	C.	F.	C.	F.	C.	F.	C.	F.	C.	F.	C.	F.	C.	F.	C.
-100	-73.3	-5	-20.6	65	18.3	135	57.2	205	96.1	275	135.0	345	173.9	415	212.8	485	251.7
-98	-72.2	-4	-20.0	66	18.9	136	57.8	206	96.7	276	135.6	346	174.4	416	213.3	486	252.2
-96	-71.1	-3	-19.4	67	19.4	137	58.3	207	97.2	277	136.1	347	175.0	417	213.9	487	252.8
-94	-70.0	-2	-18.9	68	20.0	138	58.9	208	97.8	278	136.7	348	175.6	418	214.4	488	253.3
-92	-68.9	-1	-18.3	69	20.6	139	59.4	209	98.3	279	137.2	349	176.1	419	215.0	489	253.9
-90	-67.8	0	-17.8	70	21.1	140	60.0	210	98.9	280	137.8	350	176.7	420	215.6	490	254.4
-88	-66.7	1	-17.2	71	21.7	141	60.6	211	99.4	281	138.3	351	177.2	421	216.1	491	255.0
-86	-65.6	2	-16.7	72	22.2	142	61.1	212	100.0	282	138.9	352	177.8	422	216.7	492	255.6
-84	-64.4	3	-16.1	73	22.8	143	61.7	213	100.6	283	139.4	353	178.3	423	217.2	493	256.1
-82	-63.3	4	-15.6	74	23.3	144	62.2	214	101.1	284	140.0	354	178.9	424	217.8	494	256.7
-80	-62.2	5	-15.0	75	23.9	145	62.8	215	101.7	285	140.6	355	179.4	425	218.3	495	257.2
-78	-61.1	6	-14.4	76	24.4	146	63.3	216	102.2	286	141.1	356	180.0	426	218.9	496	257.8
-76	-60.0	7	-13.9	77	25.0	147	63.9	217	102.8	287	141.7	357	180.6	427	219.4	497	258.3
-74	-58.9	8	-13.3	78	25.6	148	64.4	218	103.3	288	142.2	358	181.1	428	220.0	498	258.9
-72	-57.8	9	-12.8	79	26.1	149	65.0	219	103.9	289	142.8	359	181.7	429	220.6	499	259.4
-70	-56.7	10	-12.2	80	26.7	150	65.6	220	104.4	290	143.3	360	182.2	430	221.1	500	260.0
-68	-55.6	11	-11.7	81	27.2	151	66.1	221	105.0	291	143.9	361	182.8	431	221.7	510	265.6
-66	-54.4	12	-11.1	82	27.8	152	66.7	222	105.6	292	144.4	362	183.3	432	222.2	520	271.1
-64	-53.3	13	-10.6	83	28.3	153	67.2	223	106.1	293	145.0	363	183.9	433	222.8	530	276.7
-62	-52.2	14	-10.0	84	28.9	154	67.8	224	106.7	294	145.6	364	184.4	434	223.3	540	282.2
-60	-51.1	15	-9.4	85	29.4	155	68.3	225	107.2	295	146.1	365	185.0	435	223.9	550	287.8
-58	-50.0	16	-8.9	86	30.0	156	68.9	226	107.8	296	146.7	366	185.6	436	224.4	560	293.3
-56	-48.9	17	-8.3	87	30.6	157	69.4	227	108.3	297	147.2	367	186.1	437	225.0	570	298.9
-54	-47.8	18	-7.8	88	31.1	158	70.0	228	108.9	298	147.8	368	186.7	438	225.6	580	304.4
-52	-46.7	19	-7.2	89	31.7	159	70.6	229	109.4	299	148.3	369	187.2	439	226.1	590	310.0
-50	-45.6	20	-6.7	90	32.2	160	71.1	230	110.0	300	148.9	370	187.8	440	226.7	600	315.6
-49	-45.0	21	-6.1	91	32.8	161	71.7	231	110.6	301	149.4	371	188.3	441	227.2	610	321.1
-48	-44.4	22	-5.6	92	33.3	162	72.2	232	111.1	302	150.0	372	188.9	442	227.8	620	326.7
-47	-43.9	23	-5.0	93	33.9	163	72.8	233	111.7	303	150.6	373	189.4	443	228.3	630	332.2
-46	-43.3	24	-4.4	94	34.4	164	73.3	234	112.2	304	151.1	374	190.0	444	228.9	640	337.8
-45	-42.8	25	-3.9	95	35.0	165	73.9	235	112.8	305	151.7	375	190.6	445	229.4	650	343.3
-44	-42.2	26	-3.3	96	35.6	166	74.4	236	113.3	306	152.2	376	191.1	446	230.0	660	348.9
-43	-41.7	27	-2.8	97	36.1	167	75.0	237	113.9	307	152.8	377	191.7	447	230.6	670	354.4
-42	-41.1	28	-2.2	98	36.7	168	75.6	238	114.4	308	153.3	378	192.2	448	231.1	680	360.0
-40	-40.0	29	-1.7	99	37.2	169	76.1	239	115.0	309	153.9	379	192.8	449	231.7	690	365.6
-39	-39.4	30	-1.1	100	37.8	170	76.7	240	115.6	310	154.4	380	193.3	450	232.2	700	371.1
-38	-38.9	31	-0.6	101	38.3	171	77.2	241	116.1	311	155.0	381	193.9	451	232.8	710	376.7
-37	-38.3	32	0	102	38.9	172	77.8	242	116.7	312	155.6	382	194.4	452	233.3	720	382.2
-36	-37.8	33	0.6	103	39.4	173	78.3	243	117.2	313	156.1	383	195.0	453	233.9	730	387.8
-35	-37.2	34	1.1	104	40.0	174	78.9	244	117.8	314	156.7	384	195.6	454	234.4	740	393.3
-34	-36.7	35	1.7	105	40.6	175	79.4	245	118.3	315	157.2	385	196.1	455	235.0	750	398.9
-33	-36.1	36	2.2	106	41.1	176	80.0	246	118.9	316	157.8	386	196.7	456	235.6	760	404.4
-32	-35.6	37	2.8	107	41.7	177	80.6	247	119.4	317	158.3	387	197.2	457	236.1	770	410.0
-31	-35.0	38	3.3	108	42.2	178	81.1	248	120.0	318	158.9	388	197.8	458	236.7	780	415.6
-30	-34.4	39	3.9	109	42.8	179	81.7	249	120.6	319	159.4	389	198.3	459	237.2	790	421.1
-29	-33.9	40	4.4	110	43.3	180	82.2	250	121.1	320	160.0	390	198.9	460	237.8	800	426.7
-28	-33.3	41	5.0	111	43.9	181	82.8	251	121.7	321	160.6	391	199.4	461	238.3	810	432.2
-27	-32.8	42	5.6	112	44.4	182	83.3	252	122.2	322	161.1	392	200.0	462	238.9	820	437.8
-26	-32.2	43	6.1	113	45.0	183	83.9	253	122.8	323	161.7	393	200.6	463	239.4	830	443.3
-25	-31.7	44	6.7	114	45.6	184	84.4	254	123.3	324	162.2	394	201.1	464	240.0	840	448.9
-24	-31.1	45	7.2	115	46.1	185	85.0	255	123.9	325	162.8	395	201.7	465	240.6	850	454.4
-23	-30.6	46	7.8	116	46.7	186	85.6	256	124.4	326	163.3	396	202.2	466	241.1	860	460.0
-22	-30.0	47	8.3	117	47.2	187	86.1	257	125.0	327	163.9	397	202.8	467	241.7	870	465.6
-21	-29.4	48	8.9	118	47.8	188	86.7	258	125.6	328	164.4	398	203.3	468	242.2	880	471.1
-20	-29.0	49	9.4	119	48.3	189	87.2	259	126.1	329	165.0	399	203.9	469	242.8	890	476.7
-19	-28.3	50	10.0	120	48.9	190	87.8	260	126.7	330	165.6	400	204.4	470	243.3	900	482.2
-18	-27.8	51	10.6	121	49.4	191	88.3	261	127.2	331	166.1	401	205.0	471	243.9	910	487.8
-17	-27.2	52	11.1	122	50.0	192	88.9	262	127.8	332	166.7	402	205.6	472	244.4	920	493.3
-16	-26.7	53	11.7	123	50.6	193	89.4	263	128.3	333	167.2	403	206.1	473	245.0	930	498.9
-15	-26.1	54	12.2	124	51.1	194	90.0	264	128.9	334	167.8	404	206.7	474	245.6	940	504.4
-14	-25.6	55	12.8	125	51.7	195	90.6	265	129.4	335	168.3	405	207.2	475	246.1	950	510.0
-13	-25.0	56	13.3	126	52.2	196	91.1	266	130.0	336	168.9	406	207.8	476	246.7	960	515.6
-12	-24.4	57	13.9	127	52.8	197	91.7	267	130.6	337	169.4	407	208.3	477	247.2	970	521.1
-11	-23.9	58	14.4	128	53.3	198	92.2	268	131.1	338	170.0	408	208.9	478	247.8	980	526.7
-10	-23.3	59	15.0	129	53.9	199	92.8	269	131.7	339	170.6	409	209.4	479	248.3	990	532.2
-9	-22.8	60	15.6	130	54.4	200	93.3	270	132.2	340	171.1	410	210.0	480	248.9	1000	537.8
-8	-22.2	61	16.1	131	55.0	201	93.9	271	132.8	341	171.7	411	210.6	481	249.4	1256	637.7
-7	-21.7	62	16.7	132	55.6	202	94.4	272	133.3	342	172.2	412	211.1	482	250.0	1500	815.6
-6	-21.1	63	17.2	133	56.1	203	95.0	273	133.9	343	172.8	413	211.7	483	250.6	1750	954.4
-6	-21.1	64	17.8	134	56.7	204	95.6	274	134.4	344	173.3	414	212.2	484	251.1	2000	1093.3



# CELSIUS TO FAHRENHEIT CONVERSION TABLE

CONVERSION FORMULA  $t^{\circ}\text{C.} = (1.8t + 32)^{\circ}\text{F.}$

C.	F.	C.	F.	C.	F.	C.	F.	C.	F.	C.	F.	C.	F.	C.	F.	C.	F.
-100	-148.0	-5	23.0	65	149.0	135	275.0	205	401.0	275	527.0	345	653.0	415	779.0	485	905.0
-98	-144.4	-4	24.8	66	150.8	136	276.8	206	402.8	276	528.8	346	654.8	416	780.8	486	906.8
-96	-140.8	-3	26.6	67	152.6	137	278.6	207	404.6	277	530.6	347	656.6	417	782.6	487	908.6
-94	-137.2	-2	28.4	68	154.4	138	280.4	208	406.4	278	532.4	348	658.4	418	784.4	488	910.4
-92	-133.6	-1	30.2	69	156.2	139	282.2	209	408.2	279	534.2	349	660.2	419	786.2	489	912.2
-90	-130.0	0	32.0	70	158.0	140	284.0	210	410.0	280	536.0	350	662.0	420	788.0	490	914.0
-88	-126.4	1	33.8	71	159.8	141	285.8	211	411.8	281	537.8	351	663.8	421	789.8	491	915.8
-86	-122.8	2	35.6	72	161.6	142	287.6	212	413.6	282	539.6	352	665.6	422	791.6	492	917.6
-84	-119.2	3	37.4	73	163.4	143	289.4	213	415.4	283	541.4	353	667.4	423	793.4	493	919.4
-82	-115.6	4	39.2	74	165.2	144	291.2	214	417.2	284	543.2	354	669.2	424	795.2	494	921.2
-80	-112.0	5	41.0	75	167.0	145	293.0	215	419.0	285	545.0	355	671.0	425	797.0	495	923.0
-78	-108.4	6	42.8	76	168.8	146	294.8	216	420.8	286	546.8	356	672.8	426	798.8	496	924.8
-76	-104.8	7	44.6	77	170.6	147	296.6	217	422.6	287	548.6	357	674.6	427	800.6	497	926.6
-74	-101.2	8	46.4	78	172.4	148	298.4	218	424.4	288	550.4	358	676.4	428	802.4	498	928.4
-72	-97.6	9	48.2	79	174.2	149	300.2	219	426.2	289	552.2	359	678.2	429	804.2	499	930.2
-70	-94.0	10	50.0	80	176.0	150	302.0	220	428.0	290	554.0	360	680.0	430	806.0	500	932.0
-68	-90.4	11	51.8	81	177.8	151	303.8	221	429.8	291	555.8	361	681.8	431	807.8	501	933.8
-66	-86.8	12	53.6	82	179.6	152	305.6	222	431.6	292	557.6	362	683.6	432	809.6	502	935.6
-64	-83.2	13	55.4	83	181.4	153	307.4	223	433.4	293	559.4	363	685.4	433	811.4	503	937.4
-62	-79.6	14	57.2	84	183.2	154	309.2	224	435.2	294	561.2	364	687.2	434	813.2	504	939.2
-60	-76.0	15	59.0	85	185.0	155	311.0	225	437.0	295	563.0	365	689.0	435	815.0	505	941.0
-58	-72.4	16	60.8	86	186.8	156	312.8	226	438.8	296	564.8	366	690.8	436	816.8	506	942.8
-56	-68.8	17	62.6	87	188.6	157	314.6	227	440.6	297	566.6	367	692.6	437	818.6	507	944.6
-54	-65.2	18	64.4	88	190.4	158	316.4	228	442.4	298	568.4	368	694.4	438	820.4	508	946.4
-52	-61.6	19	66.2	89	192.2	159	318.2	229	444.2	299	570.2	369	696.2	439	822.2	509	948.2
-50	-58.0	20	68.0	90	194.0	160	320.0	230	446.0	300	572.0	370	698.0	440	824.0	510	950.0
-49	-54.4	21	69.8	91	195.8	161	321.8	231	447.8	301	573.8	371	699.8	441	825.8	511	951.8
-48	-50.8	22	71.6	92	197.6	162	323.6	232	449.6	302	575.6	372	701.6	442	827.6	512	953.6
-47	-47.2	23	73.4	93	199.4	163	325.4	233	451.4	303	577.4	373	703.4	443	829.4	513	955.4
-46	-43.6	24	75.2	94	201.2	164	327.2	234	453.2	304	579.2	374	705.2	444	831.2	514	957.2
-45	-40.0	25	77.0	95	203.0	165	329.0	235	455.0	305	581.0	375	707.0	445	833.0	515	959.0
-44	-36.4	26	78.8	96	204.8	166	330.8	236	456.8	306	582.8	376	708.8	446	834.8	516	960.8
-43	-32.8	27	80.6	97	206.6	167	332.6	237	458.6	307	584.6	377	710.6	447	836.6	517	962.6
-42	-29.2	28	82.4	98	208.4	168	334.4	238	460.4	308	586.4	378	712.4	448	838.4	518	964.4
-41	-25.6	29	84.2	99	210.2	169	336.2	239	462.2	309	588.2	379	714.2	449	840.2	519	966.2
-40	-22.0	30	86.0	100	212.0	170	338.0	240	464.0	310	590.0	380	716.0	450	842.0	520	968.0
-39	-18.4	31	87.8	101	213.8	171	339.8	241	465.8	311	591.8	381	717.8	451	843.8	521	969.8
-38	-14.8	32	89.6	102	215.6	172	341.6	242	467.6	312	593.6	382	719.6	452	845.6	522	971.6
-37	-11.2	33	91.4	103	217.4	173	343.4	243	469.4	313	595.4	383	721.4	453	847.4	523	973.4
-36	-7.6	34	93.2	104	219.2	174	345.2	244	471.2	314	597.2	384	723.2	454	849.2	524	975.2
-35	-4.0	35	95.0	105	221.0	175	347.0	245	473.0	315	599.0	385	725.0	455	851.0	525	977.0
-34	0.0	36	96.8	106	222.8	176	348.8	246	474.8	316	600.8	386	726.8	456	852.8	526	978.8
-33	3.6	37	98.6	107	224.6	177	350.6	247	476.6	317	602.6	387	728.6	457	854.6	527	980.6
-32	7.2	38	100.4	108	226.4	178	352.4	248	478.4	318	604.4	388	730.4	458	856.4	528	982.4
-31	10.8	39	102.2	109	228.2	179	354.2	249	480.2	319	606.2	389	732.2	459	858.2	529	984.2
-30	14.4	40	104.0	110	230.0	180	356.0	250	482.0	320	608.0	390	734.0	460	860.0	530	986.0
-29	18.0	41	105.8	111	231.8	181	357.8	251	483.8	321	609.8	391	735.8	461	861.8	531	987.8
-28	21.6	42	107.6	112	233.6	182	359.6	252	485.6	322	611.6	392	737.6	462	863.6	532	989.6
-27	25.2	43	109.4	113	235.4	183	361.4	253	487.4	323	613.4	393	739.4	463	865.4	533	991.4
-26	28.8	44	111.2	114	237.2	184	363.2	254	489.2	324	615.2	394	741.2	464	867.2	534	993.2
-25	32.4	45	113.0	115	239.0	185	365.0	255	491.0	325	617.0	395	743.0	465	869.0	535	995.0
-24	36.0	46	114.8	116	240.8	186	366.8	256	492.8	326	618.8	396	744.8	466	870.8	536	996.8
-23	39.6	47	116.6	117	242.6	187	368.6	257	494.6	327	620.6	397	746.6	467	872.6	537	998.6
-22	43.2	48	118.4	118	244.4	188	370.4	258	496.4	328	622.4	398	748.4	468	874.4	538	1000.4
-21	46.8	49	120.2	119	246.2	189	372.2	259	498.2	329	624.2	399	750.2	469	876.2	539	1002.2
-20	50.4	50	122.0	120	248.0	190	374.0	260	500.0	330	626.0	400	752.0	470	878.0	540	1004.0
-19	54.0	51	123.8	121	249.8	191	375.8	261	501.8	331	627.8	401	753.8	471	879.8	541	1005.8
-18	57.6	52	125.6	122	251.6	192	377.6	262	503.6	332	629.6	402	755.6	472	881.6	542	1007.6
-17	61.2	53	127.4	123	253.4	193	379.4	263	505.4	333	631.4	403	757.4	473	883.4	543	1009.4
-16	64.8	54	129.2	124	255.2	194	381.2	264	507.2	334	633.2	404	759.2	474	885.2	544	1011.2
-15	68.4	55	131.0	125	257.0	195	383.0	265	509.0	335	635.0	405	761.0	475	887.0	545	1013.0
-14	72.0	56	132.8	126	258.8	196	384.8	266	510.8	336	636.8	406	762.8	476	888.8	546	1014.8
-13	75.6	57	134.6	127	260.6	197	386.6	267	512.6	337	638.6	407	764.6	477	890.6	547	1016.6
-12	79.2	58	136.4	128	262.4	198	388.4	268	514.4	338	640.4	408	766.4	478	892.4	548	1018.4
-11	82.8	59	138.2	129	264.2	199	390.2	269	516.2	339	642.2	409	768.2	479	894.2	549	1020.2
-10	86.4	60	140.0	130	266.0	200	392.0	270	518.0	340	644.0	410	770.0	480	896.0	550	1022.0
-9	90.0	61	141.8	131	267.8	201	393.8	271	519.8	341	645.8	411	771.8	481	897.8	550	1024.0
-8	93.6	62	143.6	132	269.6	202	395.6	272	521.6	342	647.6	412	773.6	482	899.6	550	1026.0
-7	97.2	63	145.4	133	271.4	203	397.4	273	523.4	343	649.4	413	775.4	483	901.4	550	1028.0
-6	100.8	64	147.2	134	273.2	204	399.2	274	525.2	344	651.2	414	777.2	484	903.2	550	1030.0



## CONVERSION TABLES

### PRESSURE

Standard atmospheres	Metric atmospheres kg/cm <sup>2</sup>	Pounds per square inch	Millibars	mmHg	inHg
1.000	1.033	14.696	1013.20	760.00	29.921
0.968	1.000	14.223	980.66	735.56	28.959
0.068	0.070	1.000	68.95	51.71	2.036
0.987	1.020	14.504	1000.00	750.06	29.530
1.316	1.359	19.337	1333.20	1000.00	39.370
0.033	0.034	0.4912	33.86	25.40	1.000

Where 1 mb = 1000 dyn/cm<sup>2</sup>

10 mmHg = 13.5951 × 980.665 dyn/cm<sup>2</sup>

1 inHg = 25.4 mmHg

### WIND SPEED

Miles per hour	Feet per second	Centimetres per second	Kilometres per hour
1.000	1.467	44.704	1.609
0.682	1.000	30.480	1.097
0.022	0.033	1.000	0.036
0.621	0.911	27.778	1.000

Nautical Miles	Miles	Feet	Metres
1.00000	1.15100	6080.000	1853.18
0.86800	1.00000	5280.000	1609.34
0.00016	0.00019	1.000	0.30
0.00054	0.00062	3.281	1.00

## INDEX

	Page		Page
Anemograph, Bimetallic ... ..	109	Dip-Rods ... ..	84 & 85
Asbestos Cases ... ..	24	Duvdevani Dew Gauge ... ..	100
Asbestos Portable ... ..	112	Earth Thermometers ... ..	48 to 51
Asbestos Universal ... ..	112	Electrical Anemometers ... ..	14
Anemograph, Pressure Tube ... ..	18 to 20	Electrical Rainfall Recorder ... ..	98 & 99
<b>Anemometers</b>		Evaporation Hook Gauge ... ..	103
Cup Contact ... ..	14	Evaporation Indicator ... ..	102
Cup Counter ... ..	13	Evaporimeter, Piche ... ..	101
Cup Generator ... ..	15	Fahrenheit Tables ... ..	116
Hand ... ..	23	Fineman Nephoscope ... ..	110
Masts for ... ..	17 & 21	Fortin Barometers ... ..	28 to 31
Pressure Tube ... ..	18 to 20	Fronde Thermometer ... ..	54
Sensitive 3-cup ... ..	22	Frost Point Hygrometer... ..	79
Aneroid Barometers ... ..	35 & 36	Glass Cases, for Barometers ... ..	30 & 31
Angle Earth Thermometer ... ..	49	Grass Minimum Thermometer... ..	47
Assmann Hygrometers ... ..	72 to 74	Hand Anemometer ... ..	23
<b>Barographs</b>		Handbooks, Meteorological ... ..	114
Marine ... ..	39	Hook Gauge ... ..	103
Micro ... ..	40	Humidity Slide Rule ... ..	75
Open Scale ... ..	38	Humidity Tables ... ..	113
Small Pattern ... ..	37	Hydrograph ... ..	77
<b>Barometers</b>		Hygrometers	
Aneroid ... ..	35 & 36	Assmann ... ..	72 to 74
Fortin ... ..	28 to 31	Frost Point ... ..	79
Glass Cases for ... ..	30 & 31	Hair ... ..	75
Kew Pattern Station ... ..	26 & 27	Kew Pattern ... ..	69
Marine ... ..	26 & 27	Mason's ... ..	70
Observatory ... ..	32 to 34	Recording ... ..	76 & 77
Recording ... ..	37 to 40	Sheathed Pattern ... ..	67
Small Size ... ..	31	Simple Pattern ... ..	68
Station ... ..	26 & 27	Whirling ... ..	71
Besson Nephoscope ... ..	111	Inner Bottles for Rain Gauges ... ..	88
Bimetallic Actinograph ... ..	109	Inspector's Thermometer, Air ... ..	54
Boxwood Wall Thermometers ... ..	55	Inspector's Thermometer, Earth ... ..	49
Bradford Rain Gauge ... ..	84	Insulated Rain Gauge ... ..	82
Bucket for Sea Water ... ..	53	Jardi Rate-of-Rainfall Recorder ... ..	94 & 95
<b>Campbell-Stokes Sunshine</b>		Jars for Rain Gauges ... ..	87 & 88
Recorders ... ..	106 to 108	Kew Barometers ... ..	26 & 27
Canvas Bucket, Sea Water ... ..	53	Kew Hygrometer ... ..	69
Case for Air Thermometer ... ..	53	Large Size Screen ... ..	61
Cases for Sea Thermometer ... ..	53	Marine Barograph ... ..	39
Celsius Tables ... ..	117	Marine Barometer ... ..	26 & 27
Charts and Registers ... ..	113	Marine Thermometer Screen ... ..	61
Climatological Station ... ..	6 & 7	Mason's Hygrometer ... ..	70
Clinometer Compass ... ..	112	Masts for Anemometers ... ..	17 & 21
Combined Direction and		Maximum Thermometers ... ..	42 & 43
Velocity Indicator ... ..	16	Measuring Jars for Rain Gauges ... ..	87 & 88
Compasses, Service Prismatic ... ..	112	Mercury Barometers ... ..	26 to 34
Conversion Tables ... ..	118	Meteorological Charts and	
Cup Contact Anemometer ... ..	14	Registers ... ..	113
Cup Counter Anemometers ... ..	13	Meteorological Outfit ... ..	64
Cup Generator Anemometer ... ..	15	Meteorological Publications ... ..	114
Deep Sea Thermometer ... ..	51		
Dew Gauge, Duvdevani ... ..	100		
Dew Point Apparatus ... ..	78		
Dewpointer ... ..	80		





## INDEX

	Page		Page
Microbarographs ...	36 to 40	Siphon Rainfall Recorders	89 to 93
Minimum Thermometers	44, 45 & 47	Six's Thermometers ...	56 & 57
Monthly Rain Gauges ...	84 to 85	Slide Rule, Humidity ...	75
Natural Siphon Rainfall Recorder	89 to 91	Sling Hygrometer (Whirling) ...	71
Nephoscopes ...	110 & 111	Sling Thermometer ...	54
Observatory Barometer	32 to 34	Small Pattern Barograph ...	37
Octapent Rain Gauge ...	85	Small Size Barometer ...	31
"Ordinary" Thermometers ...	46	Snowdon Rain Gauge ...	82
Piche Evaporimeter ...	101	Splayed Base Rain Gauges ...	83 & 86
Plant Climate Thermometer	52	Standard Observatory Barometer	32 to 34
Pocket Aneroid Barometer	36	Station Barometer ...	26 & 27
Polymer ...	75	Station, Climatological ...	6 & 7
Portable Air Meters ...	24	Stevenson Screens ...	62 & 63
Portable Alidade ...	112	Sunshine Recorders ...	106 to 108
Portable Receiver Mk. II	13	Tables, Conversion ...	118
Pressure Tube Anemograph	18 to 20	Tables, Humidity ...	113
Prismatic Compasses ...	112	Template for Rainfall Recorder	91
Psychrometers (see Hygrometers)		Template for Sunshine Recorder	107
Publications ...	114 & 115	Terrestrial Radiation Ther-	
Rainfall Recorders		mometer ...	47
Electrical ...	98 & 99	Textbooks, Meteorological	114
Jardi Rate-of- ...	94 & 95	Thermograph ...	58 & 59
Natural Siphon ...	89 to 91	Thermohygraph ...	76
95-day ...	96 & 97	Thermometers	
Tilting Siphon ...	92 & 93	Deep Sea ...	51
Rain Gauges		Earth ...	48 to 51
Bradford, 5-in. ...	84	Fronde ...	54
Cylindrical Base, 8-in. ...	86	Grass Minimum ...	47
Howard ...	83	Inspector's Air ...	54
Inner Bottles ...	88	Inspector's Earth ...	49
Measuring Jars ...	87 & 88	Maximum ...	42 & 43
Octapent, 5-in. ...	85	Minimum ...	44 & 45
Snowdon, 5-in. ...	82	"Ordinary" ...	46
Splayed Base, 5-in. ...	83	Plant Climate ...	52
Splayed Base, 8-in. ...	86	Recording ...	58 & 59
Rate-of-Rainfall Recorder	94 & 95	Screens for ...	60 to 64
Registers ...	113	Six's ...	56 & 57
Remote Indicating Wind Vane	16	Six's, Deep Sea ...	51
Screens for Thermometers		Sling ...	54
Large Size ...	61	Terrestrial Radiation ...	47
Make-it-Yourself Kit ...	63	Wall ...	55
Marine ...	61	Wet-and-Dry Bulb ...	67 to 70
Small Size ...	60	Universal Alidade ...	112
Stevenson ...	62	Vanes, Wind ...	11, 12 & 16
Wall ...	64	Wall Thermometer Screen ...	64
Sensitive Anemometers ...	22	Wall Thermometers ...	55
Service Prismatic Compasses ...	112	Water Flow Meter ...	104
Simple Meteorological Outfit ...	64	Whirling Hygrometer ...	71
		Wind Vanes ...	11, 12 & 16