



---

---

# INTRODUCTION TO METEOROLOGY

BY

A. K. DAS, M.Sc. (Cal.), D.Sc. (Paris)

*Indian Meteorological Service*

AND

B. N. SRIVASTAVA, M.Sc.

*Department of Physics, Allahabad University*

---

---

*Price Rs. 2/-*



# CONTENTS

## CHAPTER XII

### METEOROLOGY

#### I. HISTORICAL AND GENERAL

SECTION	PAGE
1. Introduction . . . . .	359
2. History of meteorology . . . . .	360
3. The meteorological elements . . . . .	363

#### II. METEOROLOGICAL INSTRUMENTS

##### MEASUREMENT OF TEMPERATURE

4. Thermometers . . . . .	364
5. Thermometer shelter method . . . . .	365
6. The Stevenson screen . . . . .	365
7. The sling thermometer . . . . .	366
8. Ventilated thermometer (Psychrometer) . . . . .	367
9. Thermographs . . . . .	367
10. Other thermometers . . . . .	368

##### MEASUREMENT OF PRESSURE

11. Two types of barometers . . . . .	369
12. Standard Fortin's barometer . . . . .	369
13. The Kew pattern barometer . . . . .	370
14. The aneroid barometer . . . . .	370
15. Barograph . . . . .	372
16. Units . . . . .	372

##### MEASUREMENT OF WIND

17. Wind . . . . .	372
18. Wind vane . . . . .	373
19. Velocity estimations, Beaufort scale . . . . .	374
20. Anemometers . . . . .	375
21. Pressure-plate anemometer . . . . .	375
22. Rotation anemometer . . . . .	375

SECTION	PAGE
23. Pressure tube anemometer . . . . .	376
24. Exposure . . . . .	377

#### HUMIDITY

25. General idea and definitions . . . . .	377
26. Dew point . . . . .	378
27. Hygrometers . . . . .	379
28. The chemical hygrometer . . . . .	379
29. The wet and dry bulb hygrometer or psychrometer . . . . .	379
30. Dew-point hygrometers . . . . .	380
31. Regnault's dew-point hygrometer . . . . .	381
32. The hair hygrometer . . . . .	381
33. The hair hygrograph . . . . .	382

#### CLOUDS

34. Clouds . . . . .	382
35. Height of clouds . . . . .	382
36. Direction and velocity of the cloud . . . . .	383
37. The reflecting nephoscope (Fineman's) . . . . .	383
38. Direct vision nephoscope . . . . .	385
39. Sunshine recorders . . . . .	385

#### MEASUREMENT OF RAIN

40-41. Raingauge . . . . .	386
42. Recording float-raingauge . . . . .	387
43. Measurement of meteorological elements in the upper air . . . . .	387
44. Kites and kite meteorographs . . . . .	387
45. Sounding balloons and their meteorographs . . . . .	388
46. Pilot balloons . . . . .	389

#### ✓ III. COMPOSITION OF THE ATMOSPHERE

47. The Atmosphere . . . . .	391
48. Composition of Atmosphere at the surface of the earth . . . . .	391
49. The minor constituents . . . . .	393
50. Particles in the atmosphere . . . . .	393
51. Ozone . . . . .	394
52. Charged ions and free electrons in the atmosphere . . . . .	395
53. Composition of the atmosphere at great heights . . . . .	396
54. Height of the atmosphere . . . . .	398

SECTION	PAGE
<b>IV. THE HEATING AND COOLING OF THE ATMOSPHERE. SOLAR RADIATION</b>	
55. Sources of energy of the atmosphere . . . . .	400
56. Distance of the sun . . . . .	401
57. Directness and duration of solar radiation . . . . .	401
58. Variation of insolation with latitude and time . . . . .	402
59. Absorption by the atmosphere . . . . .	404
60. Pyrheliometers . . . . .	405
61. The solar constant . . . . .	406
62. Variation of solar constant . . . . .	407
63. Effective radiation . . . . .	407
64. Distribution of weather elements . . . . .	408
<b>V. DISTRIBUTION OF TEMPERATURE</b>	
65. Vertical distribution of temperature . . . . .	408
66. Troposphere and stratosphere . . . . .	411
67. Physical explanation of the existence of the stratosphere . . . . .	412
68. Inversions . . . . .	414
69. Distribution of temperature over the globe . . . . .	414
70. Annual variations . . . . .	415
71. Isothermal Charts . . . . .	416
72. Diurnal variation of temperature . . . . .	419
73. Variation with latitude . . . . .	420
74. Influence of altitude on diurnal variation of temperature . . . . .	420
<b>VI DISTRIBUTION OF PRESSURE</b>	
75. Vertical distribution of pressure . . . . .	421
76. Distribution of pressure in the stratosphere . . . . .	423
77. Convective or adiabatic equilibrium . . . . .	424
78. Diurnal variation of pressure on the earth's surface . . . . .	426
79. Variation with latitude . . . . .	426
80. Annual variation of pressure . . . . .	427
81. Isobaric charts . . . . .	427
82. Monthly isobaric charts . . . . .	428
<b>VII. WATER VAPOUR IN THE ATMOSPHERE</b>	
83. Distribution of water vapour in the lower atmosphere . . . . .	430
84. Water vapour in the stratosphere . . . . .	432
85. Diurnal and annual variation of humidity . . . . .	432
86. Methods of causing condensation . . . . .	433

SECTION	PAGE
<b>VIII. THE THERMODYNAMICS OF THE ATMOSPHERE</b>	
87. Equilibrium of the atmosphere . . . . .	435
88. Potential temperatures . . . . .	436
89. Maximum limiting value of temperature gradient, auto- convection gradient . . . . .	437
90. Adiabatic change of humid air . . . . .	438
91. Height at which condensation takes place . . . . .	441
92. Different stages of adiabatic expansion . . . . .	442
93. Forms of condensation . . . . .	444
94. Cloud classification . . . . .	446
95. Height and thickness of clouds . . . . .	449
96. Precipitation . . . . .	450
<b>IX. DYNAMICS OF THE ATMOSPHERE</b>	
97. Mean wind velocity . . . . .	454
98. Diurnal variation of wind direction and force . . . . .	455
99. Annual variation of wind . . . . .	456
100. Cause of production of wind . . . . .	457
101. Influence of earth's rotation on wind . . . . .	459
102. Frictional horizontal motion of air . . . . .	461
103. Steady rectilinear motion . . . . .	462
104. Steady horizontal motion due to curved isobars . . . . .	463
105. Friction between earth and atmosphere . . . . .	465
<b>X. GENERAL CIRCULATION OF THE ATMOSPHERE</b>	
106. Trade winds . . . . .	466
107. Doldrums and the easterly current . . . . .	466
108. The three systems of circulation . . . . .	467
109. Circulation between the equator and the tropical high pressure belt. The antitrades . . . . .	467
110. The horse latitude and the prevailing westerlies . . . . .	468
111. Circulation between tropical high pressure and the polar circle . . . . .	468
112. Modifications of the typical wind systems . . . . .	469
113. Monsoons . . . . .	470
<b>XI. MINOR CIRCULATION OF THE ATMOSPHERE</b>	
114. Depressions or cyclones of temperate zones . . . . .	472
115. Structure of a depression . . . . .	475

SECTION	PAGE
116. Evolution of a depression . . . . .	477
117. Theory of General circulation based on polar front theory .	480
118. Anticyclones of temperate zones . . . . .	481
119. Tropical cyclones . . . . .	482
120. Energy of cyclones and depressions . . . . .	488
121. Thunderstorms . . . . .	488
122. Tornadoes . . . . .	492
123. Whirlwinds . . . . .	493
124. Nor'westers of Bengal . . . . .	493
 XII. WEATHER FORECASTING AND WEATHER SERVICE	
125. Weather forecasting . . . . .	494
126. Long-range and short-range forecasts . . . . .	495
127. Weather service . . . . .	496
128. Methods of forecasting . . . . .	498
APPENDIX . . . . .	501
INDEX OF CHAP. XII (METEOROLOGY) . . . . .	507





## CHAPTER XII

### METEOROLOGY\*

#### I. HISTORICAL AND GENERAL

**1 Introduction.**—‘Meteorology’ is a branch of the larger science of Geophysics, or Physics of the earth. It deals with the phenomena which take place in the atmosphere surrounding the earth and has nothing to do with meteors. It is derived from a Greek word *τα μετε'ωρα*, meaning “the things above.”

The Science of Meteorology is again subdivided into numerous branches each dealing with a particular class of atmospheric phenomena. But the two important divisions are *Climatology* and *Dynamical Meteorology*. Climatology deals with climate in general, *i.e.*, description of various atmospheric phenomena over the globe, their study, investigation and speculation regarding their origin, as well as their relation to one another, their influence on animal and vegetable life, on public health, and also a proper estimation of the influence of geographical and topographical conditions on these phenomena. Dynamical meteorology consists principally in the study of the general laws of motion of the atmosphere, and the mode of formation and propagation of storms, depressions, etc. Dynamical meteorology also includes “thermodynamics of the atmosphere” which deals with the application of the laws of heat to such topics as formation of clouds, precipitation and study of general weather conditions. These two branches will be chiefly treated in this book. But we have, in addition, other branches such as the following:—

(i) Meteorological Optics . . . which deals with such phenomena as formation of haloes, corona, problems of visibility, etc;

\* We are deeply indebted to Mr. S. Basu of the Indian Meteorological Department for his kindly going through the manuscript of this chapter and for his valuable criticisms and suggestions.

(ii) Atmospheric Electricity . . . which deals with electrical phenomena like thunder, lightning, presence of electrified particles in the atmosphere, electrical conductivity of the atmosphere, etc ;

(iii) Acoustics of the Atmosphere . . . which deals with the study of the properties and structure of the atmosphere in relation to the propagation of sound—a branch which has, since the war, opened up new methods of sounding the upper air.

At the present time, the study of the upper atmosphere by means of radio waves, study of cosmic rays, study of phenomena like Aurora Borealis with spectroscopes are adding every year to the scope and usefulness of meteorology.

**2. History of Meteorology.**—It is clear that a science like meteorology cannot but be of the greatest significance to mankind, as it deals with subjects which are extremely important for the preservation of human life, for agriculture, navigation and other forms of human activity. The subject attracted the notice of thinking men of all ages. Amongst the Hindus, it was known as "*Abaha Vidya*" or the lore of the atmosphere and was treated in great detail by ancient savants. The astronomer Varahamihir who lived from 505—587 A.D. gives in his famous *Panchasiddhantika* a compendium of the ancient lore as preserved in his times.

The first systematic discussion of weather phenomena in Europe is due to Aristotle (384—322 B.C.) who in his book *Meteorologica* considered not only the phenomena in the earth's atmosphere but also comets, meteors, etc. After him little work appears to have been done for two thousand years till the beginning of the seventeenth century. This is the *First Period* in which observations were only qualitative. The only quantitative measurements said to have been made were those of rainfall in Korea in the Far East where rain-gauges were employed as early as 1442.

The beginning of meteorology as an exact science dates from the invention of the thermometer by Galileo in 1607. This was followed by the invention of the barometer by

Torricelli in 1643 and the application of the indications of the barometer to predict weather by Otto von Guericke, the inventor of the pump, and later by the investigations of Boyle (1654) leading to the discovery of Boyle's Law. During this period the first European rain-gauge was invented by an Italian, Benedetto Castelli in 1639 and thermometers began to be freely employed in Italy. In 1653 Ferdinand II, Grand Duke of Tuscany, established several meteorological stations throughout Northern Italy. Edmand Halley in 1686 in the *Philosophical Transactions* gave an account of the Trade Winds and Monsoons, and pointed out that they were due to a difference in temperature between the equator and the poles, and that between the land and the sea. Hadley in 1735 gave a partial account of the effect of the earth's rotation on the direction of the Trades. In 1749 Wilson of Glasgow succeeded in measuring the temperature of upper air by means of thermometers raised by kites, and Franklin in 1752 performed his famous kite experiments, which proved that the electricity of thunderclouds is identical with electricity produced on the earth by friction and other artificial means. The *Second Period* thus extends nearly to the end of the eighteenth century in which a large number of accurate observations were made.

The *Third Period* extends up to 1850 and is characterised by an attempt to furnish logical explanations of the phenomena observed, the principal investigators being Dove, Redfield, Piddington, Brandes, Espy and Loomis. Dove, a German meteorologist, gave an explanation of the general circulation of the atmosphere; Redfield in America, on the other hand, studied the problem of the origin of cyclones and arrived at important conclusions regarding the constitution of cyclones, *viz.*, the existence of the central calm and the anticlockwise wind rotation about it. The work was pursued further by Piddington who deduced certain important results. To H. W. Brandes, however, goes the credit of first introducing synoptic charts in meteorology. Espy in 1843 established the meteorological service in the United States and studied the characteristic features of cyclones. His work was supplemented by that of Loomis.

The *Fourth Period* extends from 1850 to 1865 in which the meteorological service was organised in several countries. With it are associated the names of Fitz-Roy in England, Le Verrier in France, Buys-Ballot in Holland and Ferrel in the U.S.A. The British service was organised in 1854 with Admiral Fitz-Roy at its head. In 1857 Fitz-Roy arranged for a large number of observations to be taken simultaneously over a large area and from these observations he investigated the law of storms and was even able to predict them. The same work was engaging the attention of Le Verrier in France and Buys-Ballot in Holland. Buys-Ballot first enunciated clearly the law known after his name: "If you stand with your back to the wind, then the low pressure will be on your left hand in the northern hemisphere." About 1860 Ferrel in America gave an explanation of the wind circulation over the globe.

The *Fifth Period* extends from 1870 to the present day. During this period old hypotheses were rigidly tested and compared with the ever-increasing observational data. Among the prominent workers may be mentioned Buchan in Scotland, Mohn and Bjerknes in Norway, Hildebrandsson in Sweden, Hahn, Margules and Exner in Austria, Angot in France, Shaw and Dines in England and a host of others. A special feature of this period is the large number of aerial ascents by means of kites and balloons. These led to the important discovery of the stratosphere by Teisserenc de Bort and Assmann in 1899. The other important results will be found in the text and need not be mentioned here.

In India, the initiative came from the Asiatic Society of Bengal which sent a memorandum to the Government of India on the necessity of starting a meteorological service. The proposal was accepted and the service was started in 1864. The successive director-generals have been H. F. Blandford, J. Eliot, G. T. Walker, J. H. Field and at the present time C. W. B. Normand. After the world war the Government recognized the great importance of the service for the study of the airways, and it was expanded and reorganized. The central office and observatory were shifted from Simla

to Poona, and a large number of scientific workers were recruited. The effect of this reorganization is seen in the large amount of original work which stands to the credit of the Indian Meteorological Service at the present time. It is a pity that the Government has not yet been as alive to the importance of meteorology to the rural population as they have been to considerations of an imperial nature.\*

The chief meteorological observatories in India are :—

- (i) Central Observatory at Poona.
- (ii) Upper Air Observatory, Agra.
- (iii) The Observatory at Alipore, Calcutta.
- (iv) The Observatory at Colaba (Bombay), specialising in magnetic and electrical measurements.
- (v) The Observatory at Drigh Road, Karachi.

In addition to these there are about three hundred and fifty observatories of varying grades distributed all over India which report daily observations to the forecasting centres, *viz.*, Alipore, Poona and Karachi.

**3. The Meteorological Elements.**—The state of the atmosphere at a certain place and time is numerically described by six factors. These are called the meteorological or weather elements. They are temperature, pressure, wind, humidity, clouds and precipitation. Sometimes dust and atmospheric electricity are also included.

Weather is defined as the state of the atmosphere at any place and time and is therefore best described by stating the numerical values of the meteorological elements. Thus the weather at 8 A.M. on May 6, 1932, at Allahabad is found stated in a local daily newspaper as follows :—

Barometer corrected and reduced to 32°F	...	...	29.511"
Temperature of the air...	...	...	80.1°F

\* I take upon myself the full responsibility for this statement. The authors, Messrs. Das and Srivastava are not responsible for it. (M. N. Saha)

Humidity (Saturation-100)	...	...	...	66 p.c.
Wind direction	...	...	...	E
Maximum temperature in shade	...	...	...	102.1°F
Minimum temperature in shade	...	...	...	72.2°F
Mean temperature of the day	...	...	...	87.1°F
Normal temperature of the day	...	...	...	91.3°F
Rain	...	...	...	0.20"
Total rain from 1st January	...	...	...	0.42"
Normal total up-to-date	...	...	...	1.83"

Climate is generalised weather and depends upon the average value in contrast with the particular values of the meteorological elements. For a study and reasonably accurate forecast of the weather conditions, therefore, it is of the greatest importance to be able to measure these elements accurately. To this end, a large number of instruments have been specially designed and are generally employed in meteorological observatories. To the ordinary student of physics the principles underlying most of these instruments will be very familiar. We shall therefore proceed directly to describe these instruments.

## ✓ II. METEOROLOGICAL INSTRUMENTS

In meteorological practice the chief factors governing the construction of instruments are simplicity of operation, ease of maintenance, cheapness, high standards of accuracy and avoidance of necessity for elaborate arrangements as in the laboratory. We first take the measurement of temperature.

### MEASUREMENT OF TEMPERATURE

**4. Thermometers.**—Different types of thermometers have been described in Chap. I. The real temperature of the air is the temperature attained by a thermometer in good thermal contact with the air, undisturbed by the presence of objects in the neighbourhood. It is easy to see that a thermometer exposed in the open air will not record the real temperature of the air. The thermometer records the temperature attained by the bulb and this may differ appreciably from the air temperature. The temperature attained by the bulb depends upon the conduction of

heat to or from the surrounding air and upon the difference of the heat emitted or received by the bulb by radiation. The thermal state of the atmosphere, which appears as the motive force, is determined by the atmospheric heat content, which makes the air specifically lighter or heavier and therefore causes motion of air masses. In meteorology, therefore, we have to measure the *real* temperature of the air by eliminating the effect of radiant heat on the measuring instrument, since radiant heat has practically no effect on air. A thermometer exposed in the open air will generally record a temperature higher in the day and lower at night than the real air temperature. For meteorological purposes the real air temperature is obtained in any one of the following three ways, *viz.*, by means of a sheltered thermometer, a sling thermometer or a ventilated thermometer (Psychrometers).

**5. Thermometer Shelter Method.**—This method is the one most commonly employed at fixed observation stations. The form of the shelter used by various countries is somewhat different, depending upon the latitude in which it is used but the principle underlying them all is the same. We shall describe the Stevenson Screen which is used in Great Britain and also largely in India.

**6. The Stevenson Screen.**—This was designed by Thomas Stevenson in 1866 and is represented in Fig. 1. It consists of a rectangular wooden box with a double

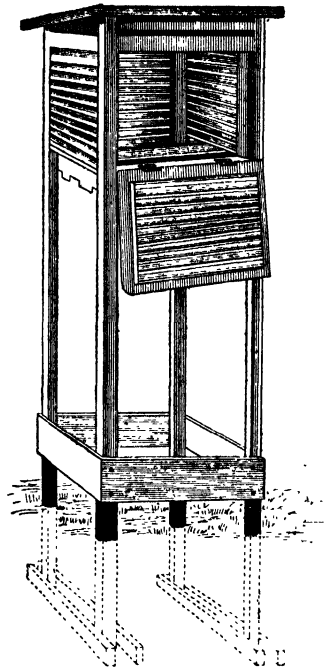

Fig. 1.—Stevenson Screen.

horizontal roof having a number of holes while the upper part has



no holes and slopes from front to back. The purpose of the double roof is to shield the thermometer effectively from solar radiation. The upper part absorbs\* the insolation and the circulation of the air between the two prevents the lower layer from becoming heated. The louvred sides allow a free circulation of air. The bottom consists of three boards arranged so that the central one is above the other two and partly overlaps them. Thus the bottom prevents radiation from the earth reaching the thermometer and at the same time allows air to circulate and the precipitated dew to go out. The screen should be placed in the open, over short grass at a height of about five feet above the ground. In a city where no open space is available the best location is the roof of a house. This does not give the temperature in the street but experiments show that this temperature is very approximately equal to the temperature of the surroundings. Under ordinary conditions the temperature indicated by the thermometer exposed in a Stevenson screen is the real air temperature correct to within half a degree, but the readings indicated are too low on still, hot summer days and too high on still, cold nights. This defect is minimized in some modern large-size shelters in which arrangements are made for whirling the thermometers (see next section).

In tropical climates such as in India where the sun's radiation is more intense, meteorological observers expose their thermometers in huts with open sides which permit of ample ventilation. Besides thermometers, other instruments are also housed in these shelters. Comparative observations of thermometers in Stevenson screens with those in huts at a large number of observatories in India have, however, shown that the difference of readings is negligibly small. Huts are, therefore, being replaced by Stevenson screens.

**7. The Sling Thermometer.**—This was devised by Arago in 1830 and possesses an advantage over the shelter method in that it is portable. It consists of two thermometers attached to a rectangular metal frame which can be rotated about one of its short sides. By whirling, a much

\* To minimise this the shelter is painted white.

larger quantity of air is brought in contact with the bulb than would otherwise be, and consequently it loses more heat by conduction. The underlying principle is to emphasize conduction so that the effect of heat exchange by radiation becomes negligible in comparison. The instrument gives the real air temperature correctly to within  $\frac{1}{8}$  °C.

**8. Ventilated Thermometer (Psychrometer).**—The aspiration thermometer of Assmann's psychrometer is the best instrument for obtaining the real air temperature. It was invented by Assmann of Berlin in 1887. It is portable and gives the real air temperature correct to  $\frac{1}{10}$  °F under any condition. The instrument is shown in Fig. 2.

It consists essentially of two sensitive mercury thermometers  $t, t'$  fixed rigidly in a framework, the bulbs being located in double jackets  $J, J'$ . The clock-driven fan  $F$  sucks air through  $g$  and thereby draws a current of air flowing past the bulb in the jackets as indicated by the arrows. Thus any stray heat received by the outer jacket is carried away by the air between the jackets and is unable to affect the bulb while the real air temperature is recorded. The framework is covered with burnished silver which reflects almost the whole of the insolation, while the thermometer stems are protected by silver shields  $S, S'$ . From these the jackets are separated by ivory rings  $R$  to prevent heat conduction. Thus the instrument readings are quite reliable even when the instrument is used in bright sunshine.

The real use of these thermometers, however, lies in their correct registration of the wet bulb temperature in the dry and wet bulb hygrometer (Sec. 29).

**9. Thermographs.**—For most purposes a continuous record of the air temperature is desirable. This is obtained by means of instruments called thermographs. They are of two types: (1) the Bourdon-tube type, (2) the bimetallic type. Thermographs are exposed in a Stevenson screen near the screen containing the set of thermometers.

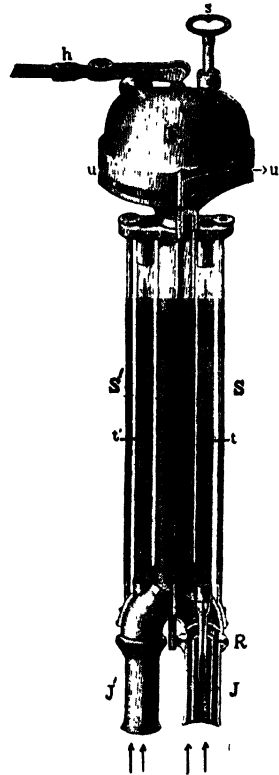

Fig. 2.—Assmann's Psychrometer.

Richard Frères thermographs of the Bourdon-tube type are in common use in India. Such a thermograph is shown in Fig. 3.

The Bourdon-tube B is of elliptical cross-section, bent into an arc of 2" radius and is silver-plated and polished on the outside. The upper end of the tube is fixed rigidly to the framework A with some play for adjusting the apparatus to the current temperature while the other end

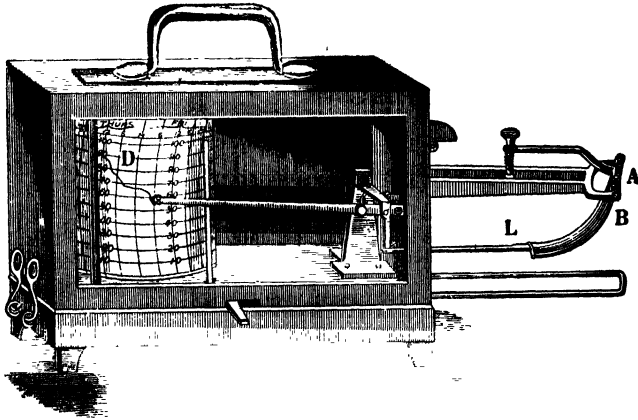

Fig. 3.—Richard Frères Thermograph.

carries a header containing a lead tube L which communicates by means of the lever mechanism to the pen-recorder. The Bourdon-tube is filled with a non-freezing liquid like alcohol at a temperature lower than the lowest the instrument is meant to record. A rise in temperature causes the alcohol to expand which tends to straighten the tube and lower the lead tube. This motion is magnified by the lever mechanism and produces a vertical rise of the pen. When the temperature falls the elastic forces increase the curvature of the tube and thereby lower the pen. The pen marks a paper attached to a revolving drum D which is driven by a clockwork inside it and makes one revolution in a week or a day. The thermograph, at best, is not an accurate instrument, and the readings must be standardised at least twice a day at suitable intervals with the help of readings of the other thermometers which are generally placed close to it.

In some instruments the Bourdon tube is replaced by a *bimetallic* curved strip. This consists of two curved strips of different metals welded together. Due to the different coefficients of expansion of the two metals the desired effect is obtained. The meteorological office of London employs a thermograph whose action depends upon the winding or unwinding action of a bi-metallic spiral. Thermographs of these types are also used by the Indian Meteorological Department.

**10, Other Thermometers.**—In addition to the temperature at a particular instant it is useful to have a knowledge of the highest and the lowest temperatures attained during a

particular period. For this purpose a maximum thermometer of the constriction pattern and a minimum thermometer with alcohol and glass index are generally used in the same Stevenson screen with the ordinary thermometers. They have already been described in Chap. I.

MEASUREMENT OF PRESSURE

11. Next to temperature, the measurement of pressure is of utmost importance to the meteorologist in forecasting weather. The instrument employed to measure pressure is called barometer, of which there are two types: (1) those employing a fluid and (2) those without a fluid. The latter are called *aneroid* barometers. In the former the fluid universally employed is mercury. We shall now describe these instruments in detail.

✓ 12. **Standard Fortin's Barometer.**—A barometer of the Fortin type is shown in Fig. 4(a) and is very largely used in observation stations. It is the standard instrument for the measurement of pressure.

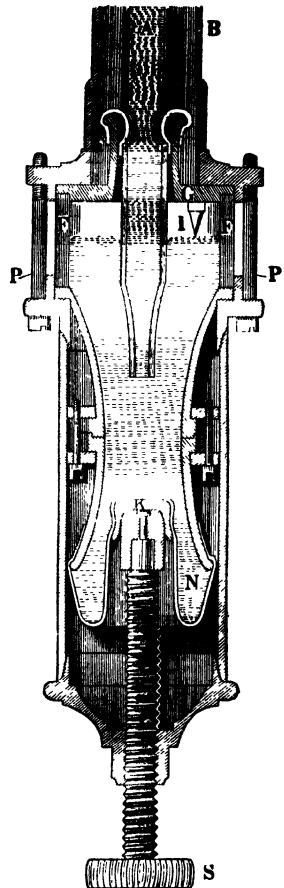
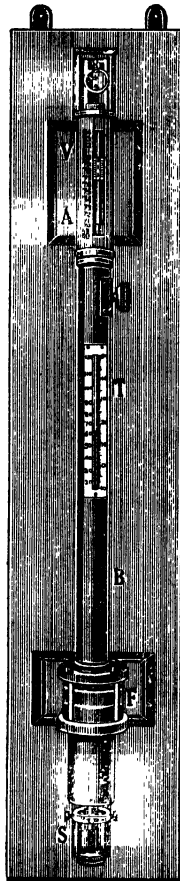

Fig. 4(a).—Fortin's barometer.

Fig.\* 4(b).—Cistern of the barometer.

\*From Milham, *Meteorology*. By permission of the Macmillan Co. publishers, F. 47

It consists essentially of a glass tube A nearly 3 feet long, filled with mercury and inverted over a vessel containing mercury, usually called the cistern. In order to protect the glass tube A it is enclosed in a brass tube B partly cut out near the top for exposing the tube and allowing observations to be taken. The readings are measured on a scale over which a vernier slides and is capable of measuring to .002 of an inch. The zero of the scale begins at the tip of the ivory pointer I fixed to the plate G in the cistern. The special feature of the Fortin cistern (Fig. 4b) consists in the manner of adjusting the mercury level to the tip of the pointer I. The neck of the barometer tube passes through the plate G to which it is fastened by a piece of kid leather. Air passes through this flexible joint to the cistern and thereby communication of the atmospheric pressure to the mercury level in the cistern is established. The cistern is provided with a glass cylinder F and is attached to the upper brass tube by three long screws P. Mercury is contained in the cistern whose lower part is made of two boxwood pieces to which is attached a bag N of kid leather passing over the socket of boxwood. Thus the level of mercury in the cistern can be adjusted by working the screw S. Sometimes the glass tube is provided with an air trap.

When reading, the level of the mercury is first adjusted by the screw S to touch the tip of I and observations are taken with the aid of the vernier. The corrections generally applied to the observed readings are: (1) the meniscus or capillary correction, (2) the temperature correction, *i.e.*, reducing the mercury height to 0°C. (3) the gravity correction, *i.e.*, reducing it to the sea-level.

**13. The Kew Pattern Barometer.**—There are other types of fluid barometers of which the most important is the Kew pattern barometer. In this the cistern, which is made of steel, is fixed and has no adjusting screw; and to allow for the rise and fall of mercury level in the cistern, the divisions on the scale are made unequal. Above a certain point the scale divisions are smaller while below it they are greater than the normal length. The scale has therefore to be graduated by reference to that of a Fortin's standard barometer. To prevent "pumping" which would occur at sea, the tube is constricted for a large part of its length. The chief advantage of such barometers is that they do not require any cistern adjustment and can be used at sea also.

**14. The Aneroid Barometer.**—As its name implies, it is a fluidless barometer. It was invented by Vidi in 1843. A typical form of aneroid barometer is shown in Fig. 5 (a) the internal construction being clearly seen in Fig. 5 (b).

It consists essentially of a vacuum box about  $1\frac{1}{2}$ " in diameter and  $\frac{1}{4}$ " thick the top and bottom of which are made of corrugated shell (1) of thin

German silver. The air has been exhausted through the tube at (12) which is then sealed. The box is prevented from collapsing by means of a strong steel spring (2) coupled by a knife-edge to the stud on the shell. Increase of pressure on the shell produces a downward motion along the axis of the shell which carries down the rod (3) together with the top of the spring. This linear motion is converted into a rotary motion by the link (4) which is transmitted by the spindle (5), lever arm (6) and link (7) to the pen axis (9) and tends to rotate it, and thereby the pointer moves. There is a helical spring (10) which keeps the linkage system taut. Decrease of pressure would have the opposite effect. It is obvious that temperature changes will also affect it similarly. This effect is compensated for either by using a suitable bimetallic rod at (3) (shown in the figure by 13) or by leaving some quantity of air in the vacuum box. The barometer is then marked "compensated".



Fig. 5(a).\*—The aneroid barometer.

The aneroid barometer is not a very accurate instrument, its readings being reliable in certain cases to '01". It must be

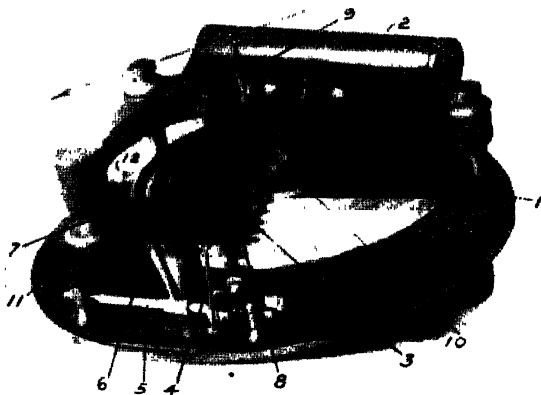

Fig. 5(b).—The internal construction of the aneroid barometer

\* From Milham, *Meteorology*. By permission of the Macmillan Co. publishers.

frequently compared with a mercury barometer. Its great advantage lies in its portability and freedom from shock. Sometimes the words storm, rain, etc., are marked on the instrument but they are meaningless.

**15. Barograph.**—For many purposes a continuous record of the atmospheric pressure is desirable. The instruments which are designed for this purpose are called barographs. The barographs generally employed in meteorological stations consist of eight or more vacuum boxes similar to that of the aneroid barometer placed one above the other so that the total displacement is eight times that for a single shell. The advantage in using a battery of boxes lies in the fact that the readings then become less dependent on the irregularities in any one single box and at the same time a large control is obtained. The displacement is magnified by a system of levers and is recorded by a pen on a revolving drum, this part of the mechanism being similar to that of the thermograph (Sec. 9). The barograph readings must however be frequently standardised by comparison with a mercurial barometer. A barograph is set up on a suitable table or bracket near the standard barometer.

It may be stated that though barographs without comparison with a mercury barometer are unsuitable for absolute measurements of pressure, yet the traces are extremely valuable in indicating barometric "tendencies," and "characteristics," *i.e.*, direction and amount of fluctuations of pressure—elements which are of growing importance in modern methods of analysis of weather charts.

**16. Units.**—In most countries the atmospheric pressure is measured in centimetres or millimetres of mercury. The Indian Meteorological Department, however, is still using the inch scale. The International Meteorological Committee have now adopted the *millibar* as the unit of atmospheric pressure. The millibar, as the name implies, is one-thousandth part of a bar or *megabarye* and a megabarye or bar is  $10^6$  *baryes*, a barye being defined as the pressure of one dyne uniformly distributed over an area of one square centimetre. A pressure of 1 bar or 1000 millibars corresponds to 750.05 millimetres of mercury, so that to convert into millibars a pressure given in millimetres, we have to multiply the number of millimetres by  $4/3$  and inversely, to convert a pressure given in millibars into millimetres of mercury we multiply by  $3/4$ .

#### MEASUREMENT OF WIND

**17. Wind.**—Air usually moves parallel to the surface of the earth, although due to local heating or cooling and also

during motion in a closed curve parallel to the earth's surface there is considerable vertical motion. It is the horizontal motion of air that is measured under the name of "wind" in meteorology. In the measurement of wind two things are required, namely the direction and the velocity. A third quantity, namely force or pressure is sometimes added, but the force is directly related to the velocity according to the relation  $P=CV^2$  where C is a constant. The constant varies slightly with the wind velocity and density.

The wind is named from the direction from which it blows; thus if the wind blows from west to east we call it a west wind. The direction from which the wind blows is called "windward" and the direction to which the wind blows is called "leeward." There are two methods of specifying wind direction: (1) by degrees, (2) by compass points. The direction is determined with reference to geographical, not magnetic bearings. When specified in degrees, the zero of reckoning is geographical north, and the measurement is carried round the complete circle in a clockwise direction. The wind direction is rarely steady and therefore it is sufficient to indicate it in terms of the sixteen divisions of the compass. When the wind direction changes steadily in a clockwise direction it is said to "veer" or "haul"; if it changes in the opposite direction it is said to "back." The direction of the wind is measured by means of a wind vane

**18. Wind Vane.**—The reader may be familiar with a wind vane which is a conspicuous figure in meteorological observatories.

We describe below the type of wind vanes used in the India Meteorological Department. It is a balanced lever (Fig. 6) which turns freely about a vertical axis. One end of the lever exposes a broad surface to the wind, whilst the other end, which is narrow, points to the direction from which the wind blows and carries a counterpoise at the end. In the most common type the broad surface consists of two plates of zinc or copper joined together at the vertical spindle



and opening out at an inclination of  $30^\circ$  leewards. This

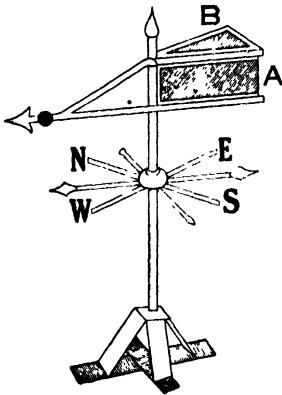

Fig. 6.—The wind vane.

movable system rotates on a steel point or ball bearings about a fixed vertical rod which carries with it a cross just below the vane. The arms of this cross are set to the four cardinal points. In some wind vanes four more direction indicators are provided.

On sea the determination of wind direction is slightly complicated by the motion of the ship, but with the help of the law of parallelogram of forces the correct direction of the wind is easily calculated from the motion of the ship and the smoke drift.

The direction of air motion other than the horizontal can be found by having two vanes, one as above, and the other capable of rotating in a vertical plane about a horizontal axis.

**19. Velocity Estimations—Beaufort Scale.**—Before instruments were constructed for the measurement of wind velocity, the strength of the wind was estimated by its effect. In 1805 Admiral Beaufort of the British Navy devised the so-called twelve-point wind scale in which twelve names for winds of gradually varying strength were introduced. Since then many other scales have been proposed from time to time, but the Beaufort scale with slight modifications has proved to be the most useful scale for the estimation of wind force. In the Appendix a Table is inserted which gives the character of the winds, the average velocity in metres per second and also in miles per hour, the pressure exerted by the winds and the characteristic effects they produce. A useful approximate formula for converting Beaufort scale into metres per second is

$$2 \times \text{Beaufort number} - 1 = \text{velocity in metres/sec.}$$

This holds good up to force 8 of the Beaufort scale.

**20. Anemometers** —The anemometer, as its name implies, is an instrument for measuring the velocity of the wind. There are many kinds of anemometers but the ordinary ones may be divided into three types: (1) the pressure-plate or deflection anemometers, (2) the rotation anemometers, (3) the pressure-tube or compression anemometers. We shall now describe these instruments.

**21. Pressure-plate Anemometer.**—It consists of an aluminium plate hinged at its upper edge and continuously adjusted by means of a wind vane to face the wind. The deflection of this plate along a circular arc gives the wind velocity. The instrument is however not capable of great accuracy.

**22. Rotation Anemometer.**— A typical example of this type is the Robinson Cup Anemometer. It consists essentially of four hemispherical cups *C* of thin aluminium or copper mounted on horizontal transverse steel arms *AA*, which are attached to a vertical steel spindle passing downwards within the casing. When the wind blows the pressure on the concave side of the cup is greater than on the convex and therefore the cups rotate with the convex side foremost. This causes the vertical spindle to rotate. At the bottom the spindle carries a steel worm wheel which communicates the motion to a recording mechanism, which is calibrated in terms of wind velocity in miles per hour on the assumption that the wind movement causing the rotation is three times the linear movement of the cup centres. This factor, three, however is not the same with all sizes of cup and wind velocity and generally a correction table is provided with the instrument to give the correct velocity.

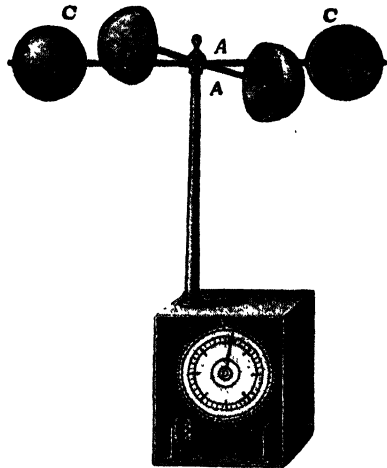

Fig. 7.—The Robinson Cup Anemometer.

The recording mechanism of the Robinson type has been replaced, in recent patterns, by a system of totalising discs. This improvement has made the reading of the instrument much simpler and this improved type is gradually replacing the older one.

The chief defect of the cup anemometer is its large moment of inertia in consequence of which it is apt to run on when the wind velocity suddenly falls or it may not take up the true velocity when the wind

velocity suddenly increases. Hence the records of sudden squalls or gusts of wind may be lost. The instrument is however extremely simple and easy to maintain and read. For measuring very small wind velocities, airmeters or pocket anemometers are employed in which a fan with a large number of vanes is used.

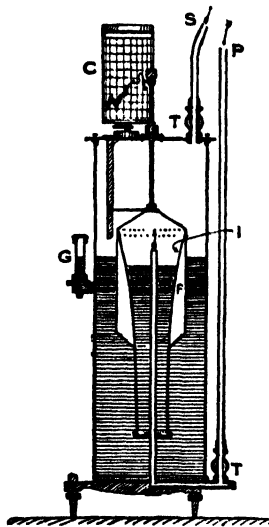
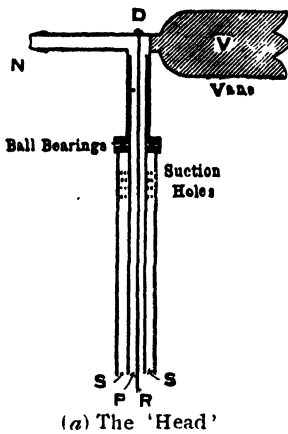

Fig. 8.—Dines' pressure-tube anemometer. (From 'Meteorology' by A.E.M. Geddes, Blackie & Son Limited).

**23. Pressure-Tube Anemometer.**

—The standard instrument of this type is the Dines' Pressure-tube Anemometer which is in common use in the British Isles. It consists essentially of two parts, the Head (Fig. 8 a) and the Recorder (Fig. 8 b) communicating with each other by means of two tubes P, S. The 'head' is placed at a height of several feet above a building and is very light and free to rotate so that by the action of the wind on the vane V, the nozzle N of the pressure-tube is kept always facing the wind. The wind blowing past N exerts a pressure which is transmitted through the pressure tube P to the inside of a float F which is kept floating inside the tank of the recorder placed in the building. There is an outer tube also leading from the head downwards past the suction holes, thereby causing a suction of the air and producing a diminution of pressure which is transmitted outside the float in the tank. The combined effect of pressure through P and suction through S is to raise the float F to which is fixed a rod carrying a recording pen. Due to its displacement upward the float raises the recording pen which is kept pressed against a chart C mounted on a revolving drum. In order that there may be no zero shift of the instrument, the surface of the liquid in the recorder must attain a fixed level whenever the pressure outside the float is made equal to that inside. The gauge G serves to indicate the constancy of the level of the liquid whenever the pressure inside and outside the float is the same. Now the force exerted by the wind is proportional to the square of wind velocity and hence the inside of the float is so shaped as to be raised and lowered in proportion to the square root of the pressure difference upon DR serves to record the direction of the

the fluid. The steel rod wind,

**24. Exposure.**—The velocity of the wind is greatly influenced by the nature of the surface over which the wind blows; as a rule it is smaller on land than on sea. On land areas the strength of the wind can vary widely from one place to another depending upon the structure of the land surface; in plains devoid of vegetation the wind can be much stronger than in plains covered with forests; in hilly tracts the wind can vary widely in force as well as in direction from place to place. Hence in order to study the normal variations of the wind it is necessary to eliminate all local or accidental influences. The place of observation must therefore be situated in the midst of the sea or on a vast plain, or even completely in the free atmosphere. The last condition is realised on the top of high towers, such as the Eiffel Tower of Paris.

#### HUMIDITY

**25.** Humidity conveys information regarding quantity of water vapour in the atmosphere. This moisture gets into the air due to evaporation from surfaces of oceans, rivers, lakes, snow-covered mountains, moist soil and from various other sources. Evaporation depends upon a number of factors, namely, the temperature of the air, the wind velocity, the pressure and the amount of moisture the air already contains. Increase of temperature and of wind velocity increases the rate of evaporation while increase of pressure and of moisture in the atmosphere decreases it. But the capacity of the air to hold water vapour is limited and depends upon the temperature only. At a given temperature a given quantity of air can hold only a certain amount of water vapour which is given by the saturated vapour pressure corresponding to the temperature, and this amount increases with increase of temperature. If the air contains all the water vapour that it can hold, it is called saturated, otherwise it is unsaturated. This amount of water vapour may be expressed in grams per cubic metre or in terms of pressure which it exerts in millimetres. If the air were absolutely dry, its humidity would be zero.

*Absolute humidity* is defined as the actual quantity of water vapour present in a given quantity of air and is generally expressed in grams per cubic metre or as the partial pressure of the water vapour present in the air. *Relative humidity* denotes the ratio of the actual quantity of water vapour present in a given quantity of air to the maximum amount that it could hold if it were saturated at the observed temperature. Relative humidity is always expressed in per cent.

Here we may remark that the sensation of discomfort due to weather experienced by the human body depends upon all the three factors, temperature, wind and humidity, and not upon temperature alone as is popularly supposed. The heat is much more oppressive on a moist hot day than on a dry hot day because on account of the presence of a large amount of moisture in the air the perspiration from the human body cannot quickly evaporate and produce cooling. Again the cold is much more penetrating on a windy day because the wind drives the cold air through the clothes to the skin. The cold is also more penetrating on a damp day because the moisture makes the clothes a better conductor of heat and thus the outside cold reaches the human body more easily.

**26. Dew Point.**—If air containing moisture is progressively cooled, a temperature will be reached at which the moisture that it contains is sufficient to saturate it. This temperature is called the *Dew Point*, for any further cooling of the air will bring about a deposition of moisture on the surface of the containing vessel in the form of dew. In the large scale phenomena occurring in the atmosphere the deposition may take any one of the different forms, *viz.*, fog, cloud, rain, frost, hail, etc.

It is easily seen that the four quantities, temperature, absolute humidity, relative humidity and dew point are inter-related and a determination of only two of them is sufficient. This is possible because we generally have a table giving the saturated vapour pressure at different temperatures. Thus if we know the temperature and the absolute humidity, the relative humidity (R. H.) can be found by dividing the absolute humidity expressed in terms of the pressure which the water vapour exerts by the saturated vapour pressure at the prevailing temperature. The dew point can be found by noting from the table the temperature at which the saturated vapour pressure equals

the value of the absolute humidity. Similarly if the temperature and the dew point be found other quantities can be calculated.

**27. Hygrometers.**—The study and measurement of moisture present in the atmosphere is called *Hygrometry* and the instruments used for measuring this amount of moisture are called hygrometers (*Hygro*=moisture, *meter*=measurer). From what has been said in the last section, it will be evident that besides temperature, we need measure any one of the three quantities, absolute humidity, relative humidity and dew-point. This gives rise to a variety of hygrometers.

**28. The Chemical Hygrometer.**—The absolute humidity can be found by means of the *chemical hygrometer*, but it is seldom used in meteorological observatories. Its action consists in extracting the moisture from the sample of air by means of drying tubes and weighing it.

**29. The Wet and Dry Bulb Hygrometer or Psychrometer.**—The relative humidity can be easily measured by means of a wet and dry-bulb hygrometer. This consists of two accurate mercury thermometers attached to a frame. Round the bulb of one of these is tied a piece of muslin to which is attached a wick extending down into a vessel containing pure water. The evaporation from the large surface exposed by the muslin produces a cooling and thus the wet bulb thermometer records a lower temperature than the dry-bulb thermometer. In the steady state there is a thermal balance between the wet bulb and the surroundings. The greater the evaporation, the greater will be the difference in temperature between the two. Now the evaporation will be greater the lesser the humidity of the air and thus the difference in temperature between the wet bulb and the dry bulb is a direct measure of the humidity. The rate of evaporation is however further affected by the pressure and the wind; large pressure tends to retard evaporation while large wind velocity accelerates it. The effect of pressure is however very small and may be

neglected, while the effect of wind is made constant by maintaining a constant supply of fresh air. This may be secured by rapidly whirling the instrument as in the sling thermometer or by arranging a good draught of air as in the Assmann psychrometer. The Assmann psychrometer has been described on p. 367 and affords the best method of obtaining the R.H. by means of the wet and dry-bulb hygrometer. The wet bulb is enclosed in the shield  $S_2$  and the dry bulb in  $S_1$ .

Below  $0^\circ\text{C}$ . however there is considerable difficulty in using the instrument.

A relation between the readings of the two thermometers and certain other quantities can be easily found. If  $T$ ,  $T'$  denote the absolute temperatures of the dry and wet bulbs respectively,  $p$  the pressure of water vapour prevailing in the air and  $p'$  the saturation vapour pressure at  $T'$ , and  $H$  the barometric pressure, the rate of evaporation will be proportional to  $\frac{p'-p}{H}$  and also to  $(T-T')$ ; therefore

$$p' - p = \Lambda H (T - T')$$

where  $\Lambda$  is some constant depending upon the conditions of ventilation and is determined from a large number of experiments. Thus knowing other quantities  $p$  and hence the R.H. can be found. Some tables for finding relative and absolute humidity by wet and dry bulb hygrometer are given in the Appendix. Ordinarily the dry bulb thermometer is identical with the thermometer for recording temperature referred to in the beginning of this chapter. The wet bulb thermometer is exposed in the same Stevenson screen as the dry one. Thus the screen contains four thermometers, the dry bulb, the wet bulb, the maximum and the minimum.

**30. Dew-point Hygrometers.**—Hygrometers in which humidity is found from a direct determination of the dew point are called Dew-point hygrometers. Examples of this type are the Daniell, the Regnault and the Dines' hygrometers. The essential principle underlying all of them is the same, *viz.*, a surface exposed to air is steadily cooled till moisture in the form of dew begins to deposit on it. The temperature is again allowed to rise till the dew disappears. The mean of the two temperatures at which the dew appears and disappears gives the dew point. These hygrometers are however rarely used in meteorological work. They differ from one another in the manner of cooling or in the nature of the exposed surface. We shall therefore describe only one of them, *viz.*, the Regnault's hygrometer.

**31. Regnault's Dew-point Hygrometer.**—This consists of a glass tube fitted with a thin polished silver thimble or cap containing ether. The mouth of the tube is closed by a cork through which passes a long tube going to the bottom of the ether, a thermometer with its bulb dipping in the ether, and a short tube connected on the outside to an aspirator. When the aspirator is in action air is continuously drawn through the ether producing a cooling and the temperature of the thermometer falls. The process is continued till moisture deposits on the surface of the thimble, and the corresponding temperature is noted. In order to help in recognising the first appearance of this moisture by comparison, a second similar tube provided with a silver thimble but without ether is placed beside it. Next the aspirator is stopped, the apparatus allowed to heat up and the temperature when the dew disappears is noted. The mean of these two temperatures gives the dew-point.

**32. The Hair Hygrometer.**—For ordinary purposes the relative humidity can be roughly measured by the Hair Hygrometer. This consists essentially of a long human hair from which all oily substance has been extracted by soaking

it in alcohol or a weak alkali solution (NaOH or KOH). When so treated, the hair acquires the property of absorbing moisture from the air on being exposed to it and thereby changing in length. Experiments have shown that this change in length is approximately proportional to the change, between certain limits, in the relative humidity of the atmosphere. Fig. 9 shows a hair hygrometer. The hair *h* has its one end rigidly fixed at A while the other end passes over a cylinder and is kept taut by a weight or a spring. The cylinder carries a pointer or index which moves over a scale S of relative humidity graduated from 0 to 100. The changes in length of the hair due to changes in humidity tend to rotate the

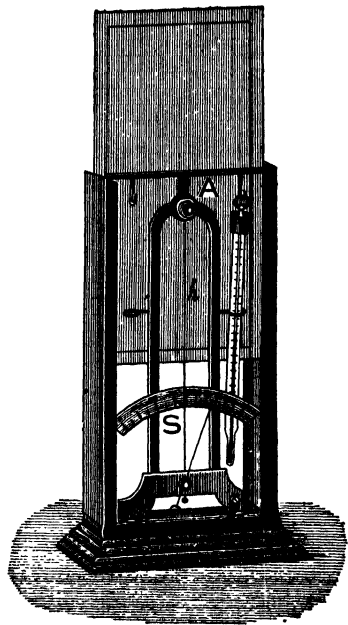

Fig. 9.—The hair hygrometer.



cylinder and thereby cause a motion of the pointer. Thus the relative humidity can be quickly read. The instrument must be frequently standardized by comparison with an accurate hygrometer or by verifying its 0 and 100 points. Its readings are then reliable to within 5%, otherwise the reading may be in error even by as much as 15%.

**33. The Hair Hygrograph.**—For obtaining a continuous record of the relative humidity the hair hygrograph is universally employed. This consists of a bundle of hairs fastened at both ends and kept taut in the middle by means of a hook attached to a lever arm. The changes in length of the hair thus cause a displacement of the hook which is communicated by a system of levers to a recording mechanism.

The wet and dry bulb thermometer may also be suitably modified to give continuous records.

## CLOUDS

**34. Clouds.**—The moisture present in the air can condense in different forms depending upon the manner in which condensation takes place. The common forms are dew, frost, fog, cloud, rain, snow and hail. Here we shall consider the measurement of the two important forms, clouds and precipitation\* which are included among the meteorological elements (p. 363).

**35. Height of Clouds.**—In the study of clouds, we are required to measure two things, the height of the cloud and its velocity. The height can be found by taking simultaneous observations of the angular elevation and the azimuth of the cloud from two stations about a mile apart. The two stations must be in telephonic communication so that the two observers may agree as to the time and the portion of the cloud to be observed. Generally in all measurements of this height, two stations and two observers are necessary. If however the observer be furnished with an accurate map of the surrounding country, observations only at one station as regards elevation, azimuth, the position of the cloud-shadow cast on the surrounding country, the time and date of observation will suffice to give the height. The height is sometimes determined by

\* This term includes the last three forms of condensation.

taking simultaneous observations from two stations by a nephoscope, which is described in Sec. 37.

**36. Direction and Velocity of the Cloud.**—The velocity of the cloud can be found by determining the heights at a known interval of time from simultaneous observations taken at two stations as explained above. Generally, however, one-station observations are taken by means of a nephoscope. Nephoscopes are of two kinds: (1) Reflecting nephoscopes and (2) Direct-vision nephoscopes. The two are essentially similar.

**37. The Reflecting Nephoscope (Fineman's).**—This instrument consists of a black circular mirror of glass mounted in a circular brass frame graduated in degrees. This frame itself is fixed to another brass ring on which the points of the compass are marked and which itself rests on a tripod whose level can be accurately adjusted. The mirror has round it

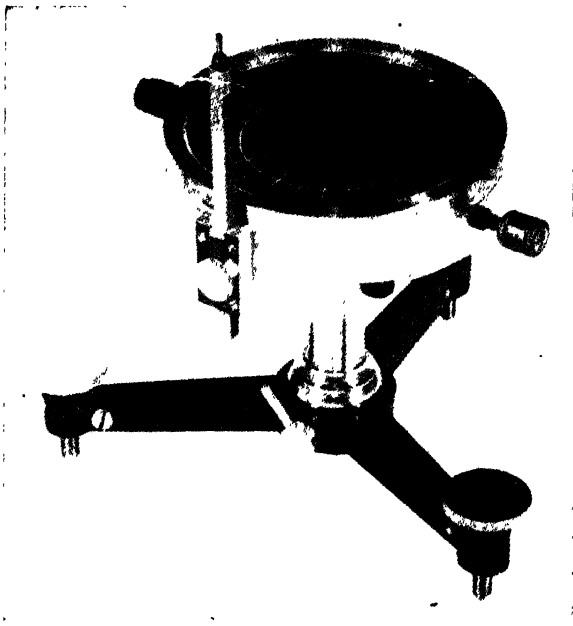

Fig. 10.—Fineman's reflecting nephoscope.

a movable brass ring which carries a vertical pointer graduated in millimetres. The pointer can be raised up or down and rotates with the brass

ring about a vertical axis. The disc of the mirror has three concentric circles and four radii drawn at right angles marked on it.

When taking an observation, the zero of the graduated circle is made to coincide with the true or magnetic north, and the pointer so moved and adjusted that the image of the cloud produced by reflection in the mirror, the centre of the mirror and the tip of the pointer are observed to be in the same line. The observer then follows the movement of the cloud image towards the periphery and notes the degree of azimuth along which the image seems to move. This gives the direction of motion of the cloud. To obtain the velocity of the cloud, the time  $t$  that the cloud image takes in traversing a distance  $d$  along this radius (*i.e.*, across the mirror) is found. Then it can be shown that

$$V = \frac{d \times H}{t \times h}$$

where  $V$  is the velocity of the cloud,  $H$  its height and  $h$  is the height of the tip of the pointer above the mirror. Thus from observations of the

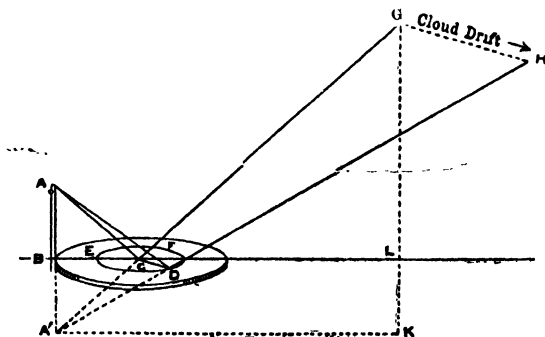

Fig. 11.—Principle of the nephoscope  
(From 'Meteorology' by A. E. M. Geddes,  
Blackie & Son, Limited.)

nephoscope alone, only the velocity-height ratio can be determined. The principle underlying the use of the nephoscope will be clear from Fig. 11.  $GH$  is the actual drift of the cloud,  $CD$  the observed drift of the cloud image,  $A$  the tip of the pointer, and  $A'$  the optical image of  $A$  in the mirror.  $L$  is the intersection of  $GK$  (a vertical line through  $G$ ) with the plane of the mirror. It is readily seen that

$$\frac{CD}{GH} = \frac{A'C}{A'G} = \frac{KL}{KG} = \frac{h}{H}$$

$$\therefore \text{cloud velocity } V = \frac{GH}{t} = \frac{H}{h} \cdot \frac{CD}{t} = \frac{H}{h} \cdot \frac{d}{t}$$

To obtain the velocity, the height  $H$  of the cloud must be determined. This can be done by taking two simultaneous observations from two stations with a nephoscope. Thus if we measure distances from  $A'$  along any two perpendicular axes and denote the distances of the image from these by  $x, y$  while  $X, Y$  denote the distances of the cloud, we have

$$H : X_1 : Y_1 = h : x_1 : y_1$$

Similarly from the other place

$$H : X_2 : Y_2 = h : x_2 : y_2 \cdot$$

$$\therefore H : X_1 - X_2 = h : x_1 - x_2$$

If the  $x$ -axis coincides with the direction of the line joining the two stations  $X_1 - X_2 = D$ , the distance between the two stations, and

$$H = \frac{h}{x_1 - x_2} D$$

**38. Direct-vision Nephoscope**—There is another type of nephoscope, called the direct-vision nephoscope, which depends for its action on principles similar to that of the reflecting nephoscope. Here instead of the image, the cloud itself is directly observed, the eyepiece, the cloud and the tip of a spike in the instrument are arranged in the same line.

The international classification of clouds is given later together with their nature and origin.

**39. Sunshine Recorders.**—Cloudiness refers to the amount of sky covered by clouds, and is generally estimated by the naked eye.

Sunshine is the converse of cloudiness and is generally measured by any one of the three types of recorders: (1) Burnt paper, (2) the photographic and (3) the electrical contact recorders. To the first category belongs the Campbell-Stokes' sunshine recorder which is in common use in most countries. It consists of a solid spherical glass lens L (Fig. 12) so arranged that it always focusses the sun's rays on a card or paper supported in a groove on the brass bowl B.

The brass bowl is part of a spherical shell concentric with the spherical lens which is contained within it. The sun's rays reaching the card produce a charred black mark on it provided the intensity is sufficiently strong. Thus from the charred record the duration of sunshine can be found. Proper adjustments, however, have to be made to ensure, that the sun's image will be formed on the card from sunrise to sunset in all seasons. For this purpose there are three cards meant to be used in different seasons on account of the varying declination of the sun and the apparatus has to be exposed with due regard to geographical meridian and latitude.

The photographic recorder, often called the Jordan recorder, consists of a light-tight cylindrical box containing photographic paper upon which the sun's rays are allowed to fall by letting in through a small hole,

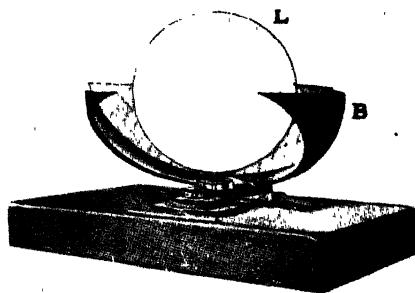

Fig. 12.—The Campbell-Stokes' sunshine recorder.

From 'Meteorology' by A. E. M. Geddes, Blackie & Son, Limited

The electrical recorder is used in the U. S. office and makes use of the heating of a thermometer bulb by solar rays.

### MEASUREMENT OF RAIN

**40.** The amount of rainfall is generally measured by a raingauge. This consists essentially of a vessel for catching the rain and a measuring glass for determining its depth. Rain-gauges were first used in Korea as early as 1422. Various forms have been employed.

**41. Raingauge.**—The 'Symon's Raingauge' described here is now in general use. It consists (Fig. 13) of (a) the funnel provided with a brass rim which should be truly circular and exactly 5 inches in diameter, (b) the cylindrical body and (c) the base which is fixed to the foundation. The rain falling into the funnel collects into a vessel kept inside the cylindrical body and is measured by means of a special measure-glass graduated in tenths and hundredths of an inch.

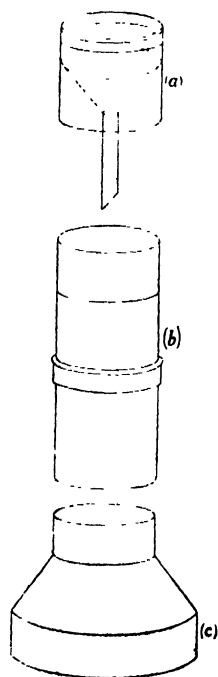

Fig. 13.—Symon's raingauge.

The funnel shape for the collector is chosen in order to prevent loss of water by evaporation. The cylindrical body *b* can collect the overflowing water in case the inner vessel becomes full. The amount of rain collected by such a gauge is affected by the presence of wind, and also by buildings.

For recording purposes raingauges have been devised of which there are two important types: (1) the tipping bucket gauge and (2) the float raingauge. In the tipping bucket gauge the rain collecting bucket is made into two compartments nicely balanced on an axle and so arranged that when one of them receives the rain and becomes filled, it tips over emptying itself into the bigger cylinder and the other compartment of the bucket is brought beneath the receiving

funnel. The process is repeated. Each tipping is recorded electrically or by an escapement actuating the pointer on a disc or raising a pen. The tipping bucket is of such size that it contains 01" of rain and in very sensitive instruments '005". (2) In the float gauge instruments the water level rising in the receiver raises a float which records mechanically against a revolving drum.

**42. Recording Float-Raingauge.**—A convenient form of the float raingauge is the natural siphon raingauge manufactured by Casella, London. This instrument has an 8" funnel and the rain water is directed to flow down gently to the receiver provided with a float and a siphon tube. The pen is mounted on the stem of the float and as the water level rises, the pen records on a clock drum the accumulation of rain water in the receiver at every instant; when the receiver is almost full the siphon is automatically brought into action at a definite stage to empty the receiver completely.

The amount of snowfall is also measured in a similar way by collecting the snow and expressing it in inches of height or in weight of water produced on melting.

**43. Measurement of Meteorological Elements in the Upper Air.**—For forecasting the state of the atmosphere for purposes of aviation and for ordinary weather forecasting, as well as for a study of the dynamics of the atmosphere, a knowledge of the meteorological elements in the upper air and of their variation with height is essential. This is accomplished with the help of some flying device such as a kite or a balloon. Aeroplanes and manned balloons also serve the purpose to a limited height. The greatest height attained by kites is 8 km., by manned balloons 11 km., by unmanned balloons 35 km. and by pilot balloons 31 km. Above this no observations have been made.

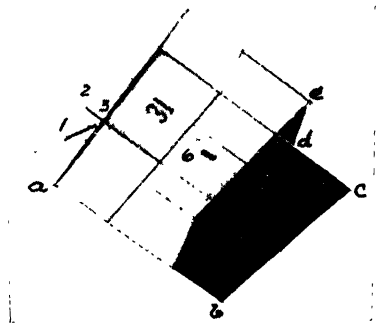

Fig. 14.—The Kite.

**44. Kites and Kite Meteorographs.**—The kite generally consists of a cellular box, rectangular in shape (Fig. 14)

to which is securely attached the meteorograph shown at (6). The bridle (1) of the kite is made of cloth-covered rubber and is connected by means of a ring to the kite wire of steel. The kite wire can be reeled over a motor-driven reel which is placed and worked in a wooden house at the ground. With the help of the motor mechanism the flight is under perfect control. The meteorographs employed are made of light metal, usually aluminium, and yield a continuous record of the meteorological elements as the kite ascends. The kite meteorograph consists of a combined mechanism with which the temperature, pressure, wind velocity and humidity are automatically recorded by four recording pens on a revolving drum. For measuring temperature a thin bronze-invar bimetallic strip of circular shape is employed, one end of which is fixed and the motion of the other indicates temperature changes. The pressure is measured by an ordinary aneroid barometer with the modification that the vacuum shells are provided with external spring to prevent their collapse under air pressure.

The wind velocity is measured and recorded by a fan anemometer (p. 376). The humidity is recorded by a hair hygograph (p. 382). A number of hairs are mounted, each so arranged that their expansion and contraction add together, thereby increasing the sensitivity. Three types of kites are employed depending upon the strength of the wind.

**45. Sounding Balloons and their Meteorographs.**—Free balloons carrying self-recording instruments are also employed for finding the state of the upper air. They are technically known as “Sounding balloons.” The balloons are generally made of pure gum rubber and are spherical in shape. The balloon is inflated with hydrogen and a meteorograph is suspended from it at a distance of 40 m. below. Beneath the meteorograph is a parachute and a basket which are all tied to the balloon. When the balloon is filled with a sufficient amount of hydrogen it ascends, carrying with it the meteorograph. As the balloon ascends the external pressure on it becomes reduced and it expands till at a great height, the internal pressure is sufficient to burst it. The meteorograph then falls down to the

earth but is protected from injury by the parachute, and is picked up and taken to the observing station. To the instrument is attached a label instructing the finder to keep it in a place of safety and communicate with the meteorological office, and for this some reward is offered.

Different types of meteorographs are employed. We shall describe the Dines' meteorograph which is in common use in England and in India. The apparatus consists of a pressure, temperature and humidity recording device. The aneroid barometer is only partially exhausted and therefore expands under the reduced pressure. This is recorded by a scratching point on a thin small metal plate. The mechanism for recording temperature consists of two bars, one of German silver and the other of invar, the temperature being measured by the expansion and contraction of the former which is magnified and recorded on the same plate. In addition a hair hygograph records humidity on the same plate. The whole instrument is enclosed in a thin aluminium cylinder having a vertical axis for the sake of protection and free ventilation. In making an ascent the aluminium cylinder is placed inside a bamboo frame which is attached to the balloon.

The bamboo frame is known as the "spider frame" and is shown in Fig. 15. The frame is hung 40 m. below the balloon. The angle which this distance subtends at a theodolite is measured from time to time by an observer and from these readings the direction and velocity of the wind can be calculated. The instrument is fairly light, weighing only about 60 gms.

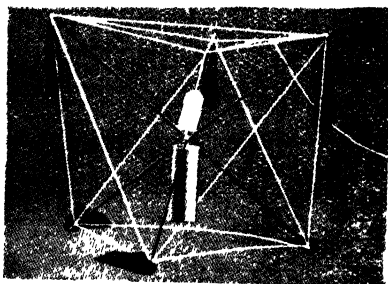

Fig. 15. - The "Spider."  
(From 'Meteorology' by A.E.M. Geddes,  
Blackie & Son, Limited)

**46. Pilot Balloons.**—For forecasting weather it is absolutely necessary to make measurements of the upper winds as a daily routine procedure. The sounding balloons with their



meteorographs are too costly\* for this purpose specially because they are liable to be lost. For this purpose therefore balloons are employed which usually carry no instruments and are much smaller and cheaper than the instrument-carrying sounding balloons. They are known as *pilot balloons* and are largely used for measuring the direction and velocity of the wind in the upper layers.

The observations are taken either with a single theodolite or with two theodolites at the ends of a suitable base line. The first method is very simple and fairly accurate specially at high altitudes. There are two usual ways of making observations with one theodolite. In one the balloon is assumed to rise vertically with a constant velocity

$$v = \frac{Q}{60} \cdot \frac{L^{\frac{1}{2}}}{(W+L)^{\frac{1}{2}}} \text{ metres/sec.}$$

where  $L$  is the free lift of the balloon in gms.,  $W$  its weight before inflation and  $Q$  a constant experimentally determined. Thus in an ascent the angles of elevation  $\theta, \theta', \dots$ , of the balloon (represented by  $P, P', \dots$  in Fig. 16)

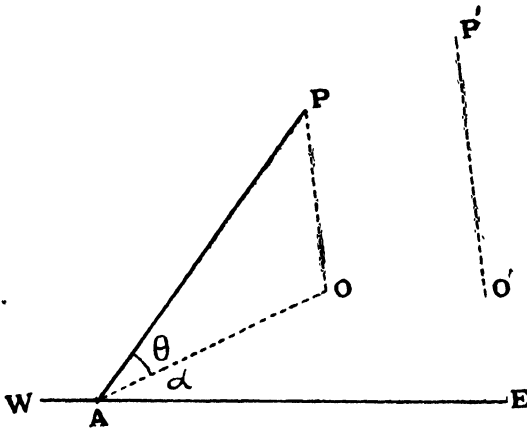

Fig. 16.—Principle of the one-theodolite method.

and azimuth  $\alpha, \alpha', \dots$  with the west-east line are determined every minute. Then

$$AO = OP \cot \theta = 60 v \cot \theta$$

\* Recently however Chatterji and Das have each devised very simple forms of temperature indicator for the upper air which can be used with pilot balloons. See G. Chatterji, *Gerland Beitr. Geoph.*, Vol. 24, p. 343 (1929). A. K. Das, *Gerl. Beitr. Geoph.*, Vol. 36, p. 4 (1932). Simple instruments for measuring the pressure and temperature inversions in the upper air have also been devised by A. K. Das [*Gerl. Beitr.*, Vols. 36 & 37 (1932)]

since at the end of 60 sec. the angle of elevation is  $\theta$ . The two components of the horizontal velocity per second during the first minute are

$$\begin{array}{ll} v \cot \theta \cos & \text{along W. E.} \\ v \cot \theta \sin & \text{along S. N.} \end{array}$$

The respective components during the second minute will be given by

$$\begin{array}{l} 2 v \cot \theta' \cos \alpha' - v \cot \theta \cos \alpha \\ \text{and} \\ 2 v \cot \theta' \sin \alpha' - v \cot \theta \sin \alpha \end{array}$$

while the vertical velocity is always  $v$ . Thus the resultant velocity as well as the direction of the wind at any time can be calculated.

The above assumption of constant rate of ascent of the balloon is not justified in practice. It is avoided in the second method of making observations with one theodolite in which the balloon is provided with a tail of known length. The angle subtended by the tail at the theodolite is measured at intervals of one minute simultaneously with the measurements of azimuth and altitude and therefore the distance of the balloon from the theodolite can be calculated from the known constants of the theodolite. This method is usually known as the "Tail method" and is used in the Indian Meteorological Department.

The two-theodolite method is a bit more complicated but dispenses with the assumption of constant vertical velocity. For a complete account of the methods of observation with the aid of balloons the reader should consult Cave, *Structure of the Atmosphere in Clear Weather*.

### III. COMPOSITION OF THE ATMOSPHERE

**47. The Atmosphere.**—The atmosphere may be defined as the gaseous envelope surrounding the earth. When at rest, one may almost doubt its existence, but when it is in motion as wind, all such doubt disappears. Now, since all the phenomena with which meteorology deals take place in this atmosphere, it is essential for a clear understanding of these phenomena to have some knowledge of its composition.

**48. Composition of Atmosphere at the Surface of the Earth.**—Air is a mechanical mixture of various gases, the two major constituents being nitrogen and oxygen. Hydrogen is also one of the permanent constituents of the atmosphere but its quantity is extremely small at the earth's surface. Besides there are present in the atmosphere various other gases such as helium, krypton, xenon, argon and neon, which are known as rare gases,\* and carbon dioxide and water vapour. The

\* See W. Ramsay, *The Gases of the Atmosphere, The History of Their Discovery*.

minor constituents of the atmosphere, often spoken of as impurities, are nitric acid, sulphuric acid, ozone, organic and inorganic particles and minute traces of several other substances. Table I gives the various gases present in the atmosphere at the surface of the earth with their molecular weights and volume percentages :

*Table I – Composition of the Atmosphere at the Earth's Surface.*

Gas	Mol. Weight	Volume per cent
Nitrogen ( $N_2$ )	28.02	78.06 (Leduc)
Oxygen ( $O_2$ )	32.00	20.90
Argon (Ar)	39.9	0.937
Carbon dioxide ( $CO_2$ )	44.0	0.29 (variable)
Water vapour ( $H_2O$ )	18.02	Variable
Hydrogen ( $H_2$ )	2.02	0.0033 (Gautier-Rayleigh)
Neon (Ne)	20.2	0.0015 (Claude)
Helium (He)	4.0	0.0005 (Claude)
Krypton (Kr)	83.0	0.0001 (approximate)
Xenon (Xe)	130.7	0.000005 (approx.)
Ozone ( $O_3$ )	48.0	Traces (Thierry)

In addition to these gases the atmosphere contains “charged particles” or ions which are present in various proportions and give rise to phenomena which are usually treated under atmospheric electricity. At greater heights, the atmosphere contains a large proportion of free electrons.

It may be remarked that except for the change in the amount of water vapour the percentage composition given above is found to be constant all over the surface of the earth in spite of the fact that air is only a mechanical mixture and not a compound. This is due to two causes: – (1) Winds carry large masses of air over great distances and produce a thorough stirring of the atmosphere; (2) Gases diffuse readily and thereby destroy any irregularity in composition even in the absence of wind. The oxygen content is found to vary from 20.81 to 21.00% by volume. The amount of carbon dioxide in free air varies from .03 to .04% by volume, being greater over the sea and less over vegetation.\* In large cities it may rise to .04% while in closed rooms occupied by many

\* This is due to the well-known action of the green cells of leaves in presence of sunlight which enables them to absorb carbon dioxide from air and retain carbon for their own growth and give out oxygen. Animals, on the other hand, inhale oxygen and exhale carbon dioxide. Thus the equilibrium between oxygen and carbon dioxide is maintained.

persons it has been found to vary from '24 to '95 %; 0'07 % is usually considered the limit of good ventilation.

**49. The Minor Constituents.**—Of the minor constituents of the atmosphere only water vapour, dust and other foreign particles and ozone deserve attention. The amount of water vapour in the atmosphere never exceeds 4% and the amount is constantly changing with change in the weather; yet it is one of the most important constituents of air, because without it, both plant and animal life would be impossible. Besides, from the meteorological point of view, the moisture content of the atmosphere is of fundamental importance, for it is one of the main factors in deciding weather. It is responsible for the various phenomena of dew, frost, fog, mist, cloud, rain, hail and snow, nearly all of which produce great effect on plant and animal life. The passage of solar light through water in the atmosphere in different physical states gives rise to several interesting phenomena such as rainbows and halos which are treated under meteorological optics. In the form of cumulo-nimbus cloud, it is responsible for the occurrence of thunderstorms which are generally treated under atmospheric electricity. We shall, therefore, discuss later in detail the distribution of water vapour in the atmosphere and the effects which it produces.

**50. Particles in the Atmosphere.**—The particles in the atmosphere are of two kinds, organic and inorganic. The organic particles are comparatively small in number and consist mainly of spores of plants and bacteria. The inorganic particles are much more numerous and are generally spoken of as dust. They play an important rôle in atmospheric phenomena. Dust is one of the chief causes of haze and probably serves as centres of condensation for particles constituting fog and clouds. It is one of the causes of the sunrise and sunset colours and of twilight. The chief causes of atmospheric dust are: (1) the action of the wind on the surface of the earth; (2) volcanic eruptions (the eruption of Krakatoa between Sumatra and Java in 1883 threw up dust and steam into the air to a height of about twenty miles and the presence of this dust could be detected in sunset colours all over the world for more than three years); (3) shooting stars on passing through the atmosphere become ignited and disintegrate; (4) ocean spray which leaves fine particles of salt in the air on evaporation. The number of dust particles in the air can be easily counted by Aitken's Dust Counter.\* Experiments show that the air in a dusty city may contain

\* The principle of this apparatus consists in adiabatically expanding a known amount of air containing dust, when due to fall in temperature some of its moisture gets condensed on the dust particles which gradually settle on a plate

as much as 100,000 dust particles per c.c. while a single puff of cigarette smoke contains about four billion particles.

**51. Ozone.**—The presence of ozone in the atmosphere can be quantitatively determined by means of its oxidizing power, say with the help of a paste of potassium iodide and starch. The amount of ozone present in the surface atmosphere is extremely small, usually about one part in a million, and shows a daily and annual variation. The amount is greater in winter than in summer and the fluctuations in its quantity are said to be accompanied by changes in weather. According to measurements made at the observatory of Parc Montsouris, Paris, there is 1.9 milligrams of ozone per 100 cubic metres of air in summer and 1.3 milligrams in winter.

In the upper atmosphere, the quantity of ozone present is much greater than that at the surface but still it is quite small; nevertheless it plays a very important part. It prevents the strong ultraviolet radiation of the sun, which would otherwise cause intense sunburn, from reaching the earth because ozone has a strong absorption in that region, absorbing practically all radiations below 3000° A. U. It absorbs as much as 6% of the incoming solar energy and in consequence the temperature of the atmosphere at the high altitude at which it occurs (about 50 km.) rises considerably and may reach even to 400°A. The amount of ozone in the upper atmosphere and the height of the ozone layer are intimately correlated with the meteorological phenomena at the surface of the earth. The subject has been carefully studied during the last five years by Lindemann, Fabry and Chalonge, Dobson<sup>\*</sup> and others. The amount of ozone present in the upper atmosphere is measured spectroscopically by the absorption of the solar ultraviolet energy which it brings about. Ozone has an absorption band between 3200 and 2200 A. U. Thus for the estimation of ozone, two wavelengths, one of which is strongly absorbed by ozone while the other is not, are photographed. Their intensities are compared by measuring the blackness of the lines by means of a photoelectric spectrophotometer. The height of ozone in the atmosphere can be estimated by making the above measurements at the time of sunrise or sunset. As a result of these investigations the following conclusions have been arrived at:—

The average height of the ozone layer is about 50 km., but it is not yet known how far below or above this height this layer extends. In temperate latitudes, the quantity of ozone varies from day to day, the variation being sometimes as much as 50% of the mean value. These

and can be counted. Moist dust free air is again introduced and the process repeated several times, and the total number of particles counted.

A very convenient and fairly accurate method of determining the amount of dust in air is with the Owen's jet apparatus (see *Proc. Roy. Soc.*, 1922), Vol. 101, pp. 18-37). In this apparatus a jet of the dusty air is made to impinge at a high velocity upon a glass surface, such as a microscope slide. Under suitable conditions of humidity and velocity the dust particles adhere to the glass surface and can be examined microscopically.

\* Dobson, *Nature* (1931), p. 668; also papers by Fabry and Buisson, Götz, Chapman and others.

variations show a close connection with the meteorological conditions in the atmosphere, particularly with the temperature and the pressure, the correlation coefficient being as high as '80. The amount of ozone is large when these temperatures and pressures are small. Some connection has also been traced between the amount of ozone and terrestrial magnetic phenomena, days of high magnetic character being accompanied with much ozone.

There is also an annual variation in the quantity of ozone outside the tropics, it being maximum in spring and minimum in autumn while within the tropics no appreciable variation is observed, the result being that the quantity increases rapidly as we pass from the equator to the pole in spring and remains practically constant in autumn throughout the whole hemisphere.

The question naturally arises: How is ozone formed in the upper atmosphere and how is it so closely associated with the weather conditions? The question has not yet been definitely and completely solved as the existing data are very meagre. Various suggestions, however, have been made such as (1) the breaking up of oxygen molecules into atoms by the ultraviolet solar radiation and their recombination to form ozone; (2) formation due to the action of aurora. The latter suggestion appears to be more in accordance with facts. Lightning certainly produces some ozone. Much more experimental work is, however, necessary in order to settle this point which is yet an open question. The large amount of ozone in the rear of a cyclone has also not yet been explained.

## 52. Charged Ions and Free Electrons in the Atmosphere. —

During the first few years of the present century it was definitely established that radio waves possess the property of overcoming the curvature of the earth, and reaching distances which could not be explained. For example, if a wave sent from London is received at New York, it could not have travelled in a straight line as theories of light propagation demand, but must have followed the curvature of the earth. Kennelly and Heaviside, in 1900, simultaneously proposed the existence of an ionised layer (composed of charged particles) in the upper atmosphere. Owing to the presence of these free electrons the waves are almost completely reflected. Thus they are confined within a layer contained between the surface of the earth and a concentric sphere having a height of about 100 km. and succeed in reaching the destination by successive reflections.

The existence of this ionised layer has been definitely proved by radio methods by Appleton and Barnett,\* Breit and Tuve,† and others. The usual height is about 100 km. but it depends on the season and the hour of the day as well as the latitude of the place. It is known from studies in atmospheric electricity that ions are present in the atmosphere even at ordinary heights, and that the concentration of these ions at first increases slowly with the height and then increases rapidly.

\* *Proc. Roy. Soc. Lond. A.*, Vol. 109, p. 621 (1925); Vol. 113, p. 450 (1926).

† *Phys. Rev.*, Vol. 28, p. 554 (1926).

Ultimately a fairly good conducting layer is formed, which diffracts the short waves and reflects the longer ones. The density of electrons in this conducting layer known as the Kennelly-Heaviside layer, is of the order of  $10^3$  electrons per c.c. Figure 17 shows the variation of electron concentration with the height.

In addition to this conducting layer Appleton and Green\* have been able to establish the existence of a second ionised layer at a height of about 200 kms. It is only during a very short time in the day that both these layers are present simultaneously, but usually one layer is present and then suddenly the other layer is detected, which means that ordinarily there are two layers present, and that when the electron density in the

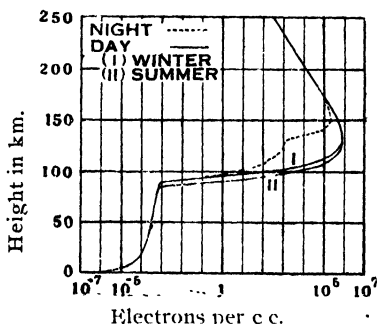

Fig. 17.—Electron concentration at different heights.

lower layer becomes small, the waves penetrate and are reflected from the upper one. The curious phenomena of skip distance and short interval echoes experienced in broadcasting have been satisfactorily explained on the assumption of the existence of these ionised layers. But in 1928 Störmer† and Van der Pol came across echoes occurring after an interval of as much as 30 seconds, an interval in which the waves can travel a distance of about 240 times the circumference of the earth. Störmer has suggested that this is due to a stream of electrons coming from the sun which is bent in the form of a torus by the earth's magnetic field at a distance of about a million miles thereby forming a conducting layer. On the other hand, according to Van der Pol‡ and Appleton§ the waves do not pass through the Kennelly-Heaviside layer but travel in a region of the atmosphere, where conditions are such that the group of waves is compressed and 'bottled' for some time, since the group velocity approaches zero, and after some time gets reflected from a certain layer. The matter is, however, not yet settled beyond dispute.

### 53. Composition of the Atmosphere at Great Heights.—

The percentage composition given in Table 1 is found to hold true up to a height of about 11 kilometres or 7 miles, the greatest height at which man can live; above this, however, the composition is different. As we shall see later, the earth's atmosphere consists of two sharply defined strata, *viz.*, the *troposphere* and the *stratosphere*. The troposphere extends

\* *Proc. Roy. Soc. Lond. A.*, Vol. 128, p. 160 (1930).

† *Nature*, Vol. 122, p. 681 (1928).

‡ *Nature*, Vol. 122, p. 878 (1928).

§ *Nature*, Vol. 122, p. 879 (1928).

from the surface of the earth to a height of 11 kilometres over temperate latitudes in which the composition is rendered constant throughout by means of convection currents and there is a definite temperature-gradient. In the stratosphere, however, the temperature appears to remain almost the same throughout and hence the gases will distribute themselves in such a way that the heavier gases preponderate in the lower layers and the lighter ones in the upper layers. Formulæ are deduced later (see Secs. 75 and 76) from which the quantity of gas at different heights can be calculated.\* In this way the composition of the atmosphere at different heights has been calculated by Humphreys and the results are given in Table 2† (p. 398). Figure 18 represents the results graphically. A number of

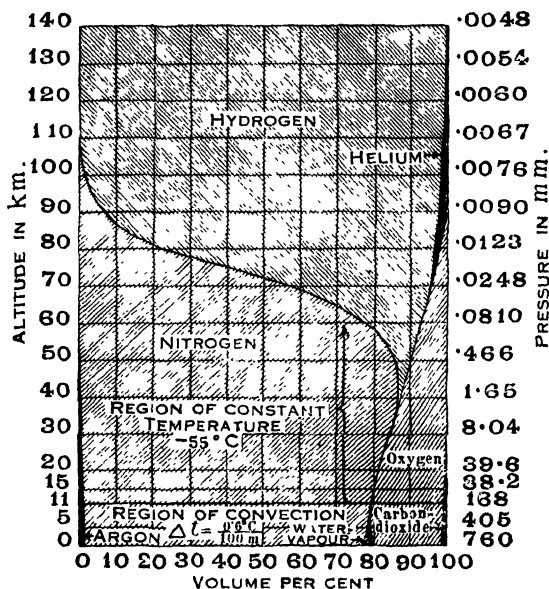

Fig. 18.—Percentage composition of the atmosphere at different heights, atmospheric gases which occur in very small quantities are not included in the table and the figure. It should be borne in mind

\* For detailed discussion see Humphreys, *Physics of the Air*, pp 61—68.

† Reproduced from Humphreys *Physics of the Air*, published by McGraw-Hill Book Co.



that the values given in the table are supported by experimental observation only up to a height of about 30 kilometres above which no data are available.

The density of the atmosphere depends on the distribution of temperature and of water vapour and on the distribution of pressure. The variation of density and pressure with altitude over North-West Europe is represented in Table 3.\*

Table 2.— *Composition of the Atmosphere at Different Heights in Volume Percentages.*

Height in kilometre.	GASES.							Total pressure in millimetres.
	Argon.	Nitrogen.	Water vapour.	Oxygen.	Carbon dioxide	Hydrogen.	Helium.	
140	..	0·01	...	...	...	99·15	0·84	0·0040
130	..	0·04	...	..	...	99·00	0·96	0·0046
120	..	0·9	...	..	...	98·74	1·07	0·0052
110	..	0·67	0·02	0·02	...	98·10	1·19	0·0059
100	..	2·95	0·05	0·11	...	95·58	1·31	0·0067
90	..	9·78	0·10	0·49	...	88·28	1·35	0·0081
80	..	32·18	0·17	1·85	...	64·70	1·10	0·0123
70	0·03	61·83	0·20	4·72	...	32·61	0·61	0·0274
60	0·03	81·22	0·15	7·69	...	10·68	0·23	0·0935
50	0·12	86·78	0·10	10·17	...	2·76	0·07	0·403
40	0·22	86·42	0·06	12·61	...	0·67	0·02	1·84
30	0·35	84·26	0·03	15·18	0·01	0·16	0·01	8·63
20	0·59	81·24	0·02	18·10	0·01	0·04	...	40·99
15	0·77	79·52	0·01	19·66	0·02	0·02	...	89·66
11	0·94	78·02	0·01	20·99	0·03	0·01	...	168·00
5	0·94	77·89	0·18	20·95	0·03	0·01	...	405·00
0	0·93	77·14	1·20	20·69	0·03	0·01	..	760·00

If for European latitudes we draw curves representing the density of air as a function of the latitude, we find that the two curves for summer and for winter intersect at about 8,500 metres. At this level known as the level of constant density, the density of the atmosphere remains practically constant throughout the year. Below it the densities in summer are smaller than those in winter while above it the converse holds true.

**54. Height of the Atmosphere.**—Since the gases in the atmosphere are free to expand, it is obvious that there can be no theoretical limit to the height of the atmosphere. It must continue to become thinner and thinner as the altitude increases until it tends to absolute vacuum in the interplanetary space which may be broken by a few straggling molecules.

\* Reproduced from Humphreys, *Physics of the Air*.

Table 3.—Average Pressure and Density of Air at Different Heights.

Altitude in kilometres above sea-level	Summer			Winter		
	Total pressure	Pressure of water vapour	Density in grams per cubic metre	Total pressure	Pressure of water vapour	Density in grams per cubic metre
0·0	762·55	10·46	1224·42	763·35	4·69	1287·58
0·5	718·75	9·17	1159·17	717·42	4·35	1212·31
1·0	677·24	7·81	1099·61	674·11	3·56	1147·23
2·0	600·31	4·97	995·19	594·37	2·27	1025·03
3·0	530·82	3·12	897·73	522·99	1·30	919·87
4·0	468·23	1·87	808·07	458·91	0·72	826·62
5·0	411·93	1·06	726·57	401·32	...	743·33
6·0	361·32	0·57	653·35	349·62	...	666·41
7·0	315·84	...	587·39	303·34	...	596·05
8·0	274·98	...	527·26	261·94	...	530·41
9·0	238·39	...	471·70	225·37	...	468·61
10·0	205·77	...	418·94	193·19	...	410·34
15·0	95·66	...	201·06	87·99	...	189·20
20·0	44·37	...	93·25	40·09	...	86·20
25·0	20·60	...	43·29	18·28	...	39·31
30·0	9·58	...	20·13	8·35	...	17·95
35·0	4·46	...	9·37	3·82	...	8·21
40·0	2·08	...	4·37	1·75	...	3·76

From the tables it will be seen that half of the total gas occurs below a height of 3·6 miles. If the density of the atmosphere were uniform throughout and the same as the value observed at the earth's surface, it would extend to a height of about 5 miles. This height is often spoken of as the height of the *Homogeneous Atmosphere*, and can be found from the relation  $g\rho H = p_0 = 10^6$  dynes/cm.<sup>2</sup> where  $\rho$  is the density of air and is equal to 001293 gm. per c.c.,  $p_0$  the atmospheric pressure on the earth's surface. Putting  $g = 981$ ,  $H$  comes out to be 7·9 kilometres. For most purposes, however, we are interested in finding out the height up to which the air exists in perceivable quantities. This is called the sensible height of the atmosphere and can be detected in any one of the following ways: (1) by observations of the duration of twilight; (2) by observations of maximum height of clouds (this shows the presence of water vapour and hence of air); (3) by observations of the height of shooting stars (these are simply masses of matter or meteors rendered incandescent by heat developed by friction when they traverse the earth's atmosphere with the enormous velocity of several miles per second); (4) by observations of the height of Aurora Borealis or northern lights (supposed to be due to electrical discharges in the rarefied gases of the upper atmosphere). Taking into consideration the different methods it may be stated that up to a height of 300 kilometres air exists in perceptible quantities.

#### IV. THE HEATING AND COOLING OF THE ATMOSPHERE: SOLAR RADIATION

**55. The Sources of Energy of the Atmosphere.**—The primary cause of almost all meteorological phenomena is to be looked for in the energy which the sun sends us in the form of radiation, and in the manner in which this energy is absorbed or re-emitted by the earth's crust and atmosphere. There may be, however, other sources of atmospheric heat, for example, the heat coming from the earth's interior by conduction and the radiation of stars and other heavenly bodies. But the heat supplied by the earth's interior would be always the same everywhere be it the equator or the pole, day or night, winter or summer. The stars shine by day as well as by night and on all portions of the earth's surface. Changes in the temperature of the atmosphere cannot thus be accounted for by the heat from the earth's interior, or from stars. Direct measurements have also shown that the total amount of heat supplied by all sources other than the sun is not sufficient to change atmospheric temperature by  $0.14^{\circ}\text{C}$ . Bond and Zöllner estimate the intensity of moonlight at about  $1.6 \times 10^{-6}$  of solar light. Attempts\* have also been made to determine whether the temperature at the surface of the earth is slightly higher during full moon than during new moon, but without any result. The effect of lunar heat on meteorological phenomena is therefore negligible, and consequently the effect of the heat derived from all the planets can be safely considered insignificant. It is, therefore, mainly the sun which controls the heating of the atmosphere.

The radiant energy received from the sun is given the special name of *insolation*. The amount of insolation at any particular time and place depends upon the following :—

1. Distance from the sun, since insolation varies inversely as square of the distance.

\* Buys-Ballot, *Pogg. Ann.*, Vol 70, p. 163; and Vol 84, p. 530.

2. Inclination of the rays to the horizon or solar elevation, since the rays when falling obliquely upon a surface are spread out over a larger area than when falling perpendicularly.
3. Duration, *i.e.*, length of the day.
4. Transmission and absorption by the atmosphere.
5. Output of solar radiation.

**56. Distance of the Sun.**—The variation in the first three factors is brought about by the revolution of the earth round the sun. In order to understand these variations, therefore, we must study in some detail how the earth revolves round the sun. The attraction between the earth and the sun is gravitational and varies inversely as square of the distance between them. Now since the sun is stationary, it follows from principles of dynamics that the earth must revolve round the sun in an elliptic orbit. This orbit is traversed in  $365\frac{1}{4}$  days approximately. The plane of the orbit of the earth is called the plane of the ecliptic. The eccentricity of the orbit is very small so that the orbit is nearly circular. The average distance of the earth from the sun is  $9.3 \times 10^7$  miles but the actual distance varies by about  $1.5 \times 10^6$  miles in either direction or about 3.3% in the course of a year. The earth is nearest to the sun on December 31 (perihelion) [Fig. 19 (a)] and most distant on July 1, (aphelion). Due to this variation in the distance of the earth from the sun more insolation must be received in January than in July. The difference on this account alone amounts to 6.6.

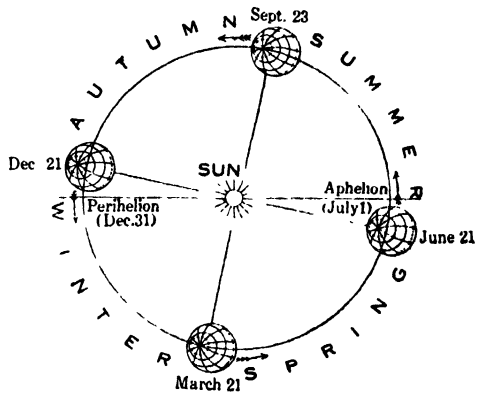

Fig. 19(a).—The orbit of the earth

**57. Directness and Duration of Solar Radiation.**—The axis of the earth is inclined to the plane of the ecliptic at an

angle of  $66\frac{1}{2}^\circ$  and this axis remains parallel to itself as the earth revolves round the sun. The north pole and the northern hemisphere of the earth are turned most directly

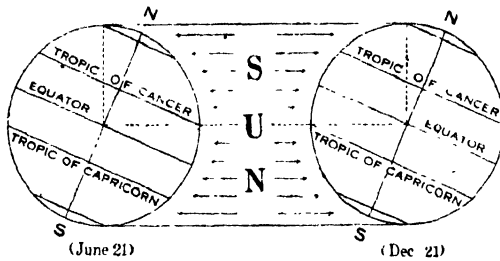

Fig. 19(b).—Presentation of the earth to the sun.

towards the sun on June 21 (summer solstice) and away from it on December 21 (winter solstice). The change in the presentation of the earth to the solar radiation gives rise to an apparent

migration of the sun northward from December 21 until June 21 and southward from June 21 until December 21. At the equator the sun is directly overhead at noon on March 21 (spring equinox), at the Tropic of Cancer [Fig. 19 (b.) on June 21; at the equator again on September 23 (autumn equinox) and at the Tropic of Capricorn on December 21. This migration of the sun causes marked changes in the directness of the sun's rays, and in the length of the day. The noon elevation of the sun changes by  $47^\circ$  ( $2 \times 23\frac{1}{2}$ ) in the course of the year, and this produces a great change in the insolation received at any particular point. Table 4 gives the greatest possible duration of insolation for different latitudes.

Table 4.—Duration of Insolation at Different Latitudes.

Latitude ...	0	17°	41°	49°	63°	66°30'	67°21'	69° 51'	78°11'	90°
Duration ...	12h	13h	15h	16h	20h	24h	1 mo.	2 mo.	4 mo.	6 mo.

### 58. Variation of Insolation with Latitude and Time.—

Since the three factors discussed above have different values for different latitudes and times of the year, it follows that the insolation received varies with the latitude and the time of the year. Thus on 21st June more insolation is received during the day at the north pole than on the equator, for though the noon elevation of the sun is less at the pole ( $23\frac{1}{2}^\circ$ ) than at the equator ( $66\frac{1}{2}^\circ$ ), yet the duration of the sun is longer in the ratio of 24 hours to 12 hours. Thus the effect of duration

more than compensates the effect of directness. The net effect is complicated and can be represented by a diagram in space with insolation, temperature and time as its coordinates.\*

At the equator the quantity of heat received during the two days of the equinoxes is greater than at any other time, and the insolation during the two days of the solstices is the smallest. The heat received in a day at the equator therefore undergoes a double oscillation in the course of the year with maxima at the equinoxes and minima at the solstices (Fig. 20). Owing to the ellipticity of the earth's orbit, however, the distance of the sun at the summer solstice is greater than at the winter solstice and therefore the winter maxima is greater by about 7%. However in spite of the

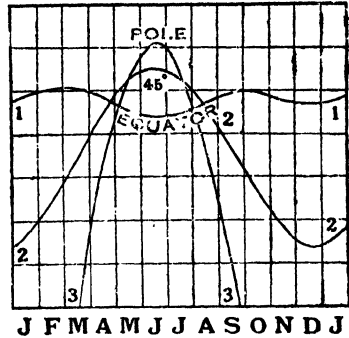

Fig 20.—Annual variation of insolation at different latitudes.

inequality of the two oscillations the total quantity of heat received at the equator from the spring equinox to the autumn equinox is exactly the same as that received from the autumn equinox to the spring equinox,† because the ellipticity of the orbit which causes the variation of the distance from the sun also produces a variation in the length of the seasons. Between the spring equinox and the winter equinox there are 186 days, while there are only 179 days between the winter equinox and the spring equinox. Thus the earth is farther from the sun during the longer season.

Let us now consider a point of the northern hemisphere between the Equator and the Tropic of Cancer. The curve representing the annual variation of the heat received in a day is similar to the curve 1, only the minimum of December is deeper and becomes wider the farther we recede from the equator, at the same time the minimum of June shrinks and gradually fills up due to the progressive approach of the two maxima between which it is situated. At the tropics the

\* See Davis, *Elementary Meteorology*.

† This result can be deduced mathematically as follows:—From the law of equal areas discovered by Kepler

$$R^2 d\theta = C dt$$

where R is the solar distance,  $d\theta$  the angle at the sun swept over by the earth in time  $dt$ , and C a constant. Further if  $dQ$  is the amount of solar energy incident upon the earth in time  $dt$  and I the solar constant at unit solar distance,

$$dQ = \frac{I}{R^2} dt, \text{ hence } dQ = \frac{I d\theta}{C}$$

or the energy received by the earth from the sun during a certain time is directly proportional to the angular distance between the initial and final radii vectors. Since the earth's axis remains parallel to itself during the motion it follows that each hemisphere must be inclined towards and away from the sun over exactly one-half of the orbit and hence the heats received by the two hemispheres during the year must be equal. Further also the amount of radiation received by the earth during the aphelion half of its orbit must be exactly equal to that received during the perihelion half.

two maxima get confused and the curve shows only one maximum in summer and a single minimum in winter, which is characteristic of the temperate zone. At the tropic and beyond it, the length of the day as well as the height of the sun above the horizon at a given hour of the day increases steadily from the winter solstice to the summer solstice, and decreases steadily during the second half of the year; there is thus only one maximum and only one minimum, as shown by the curve 2.

As we approach the Arctic Polar circle the amount of heat which reaches the earth in winter diminishes and at the Polar circle itself the sun does not rise on 21st December, so that the insolation is zero on that date. Inside the Polar circle the length of the night about the time of the winter solstice increases as we approach the pole and at the pole itself the sun never rises from the 22nd September to the 20th March. On the other hand, the sun never sets from the 20th March to the 22nd September. The height of the sun above the horizon increases gradually till the 21st June and then decreases, the insolation also undergoes the same variation and is shown by the curve 3 (in the figure).

For the southern hemisphere the above considerations would be equally applicable if we just interchange the seasons. But one peculiarity may be noted. When it is summer in the southern hemisphere, the sun is nearest to the earth, while during winter he is farther off. Thus the effect of the variation of solar distance is to accentuate the difference between the summer and the winter in the southern hemisphere, while in the northern hemisphere the effect is opposite.

**59. Absorption by the Atmosphere.**—Up till now we have confined ourselves to the consideration of the heat which the sun sends to the earth, that is, the heat which reaches the outer limit of the atmosphere. A considerable portion of this incoming radiation is, however, lost completely by reflection and scattering by the terrestrial atmosphere and is sent back to the interstellar space. The amount so lost is about 37% for the whole earth. The best reflecting constituents of the atmosphere are water, snow and cloud. According to the recent measurements at Mount Wilson and elsewhere the reflecting power of the clouds is as high as 78%. The scattering is partly due to the dust molecules and partly to the air molecules and is generally small. Further, some of the constituents exert selective absorption on certain kinds of radiation. The most marked absorption is caused by water vapour, carbon dioxide, ozone and oxygen. Thus the heat transmitted to the earth's surface varies with the composition of the atmosphere as well as with the incident solar radiation. It is therefore necessary to determine experimentally

the coefficient of transmission or transparency of the atmosphere.

It follows from Biot's law that the quantity of energy absorbed increases geometrically with the quantity of absorbing material traversed provided it is all under the same physical condition and homogeneous. The loss of radiation due to scattering also follows the same law though the coefficients of direct absorption and of extinction due to scattering are quite different. Nevertheless if  $I_0$  be the initial intensity of the radiation of a given wavelength and  $aI_0$  the intensity after transmission normally through a layer of unit thickness, then the intensity after transmission through a layer  $m$  units in thickness can be written as

$$I_m = I_0 a^m \quad \dots \quad (1)$$

$a$  is called the coefficient of transparency and generally varies from 0.55 to 0.85. This is in accordance with the well-known law stated for the first time by Bouguer, *viz.*, "For a given coefficient of transmission the quantity of heat transmitted decreases in geometrical progression as the mass of the atmosphere traversed increases in arithmetical progression."

In the atmosphere there is no homogeneity in dust content or in density in a vertical direction but approximate homogeneity exists in a horizontal direction. Thus, as already mentioned on p. 353 observations of the intensity are taken with different elevations of the sun when  $m$  varies as see 1. Table 5 gives the various values of the thickness of the atmosphere for different altitudes of the sun.

*Table 5 — Thickness of the Atmosphere traversed for Different Altitudes of the Sun.*

Altitude of the Sun	0°	5°	10°	20°	30°	50°	70°	90°
Thickness of Atmosphere.	35.5	10.2	5.56	2.90	1.99	1.31	1.06	1.00

**60. Pyrheliometers.**—The instruments employed for measuring the solar radiation are called pyrheliometers or actinometers. The various methods employed make use of calorimetric arrangements, a pyrheliometer,



a bolometer, a thermoelectric couple, a photographic paper, a black-bulb thermometer, chemical decomposition and so forth. The absolute pyrhelimeter has already been described on page 351 where a reference to some of the earlier instruments was also made. Another practical form is the 'compensation pyrhelimeter' of Ångström. In this instrument there are two thin strips of metal identical in every way which serve as the calorimetric body. One of these is exposed to the sun, while through the other, which is kept in shade, an electric current is passed. The strength of the current is so regulated that the temperatures of the two strips, as indicated by thermocouples attached in opposition, is the same. The energy of the incident radiation is then equal to the electrical energy supplied. If the breadth of the strips is  $b$ , their absorption coefficient  $a$  and the incident radiation equal to  $h$  per sq. cm. per minute, then the radiant energy received per unit length of the strips is  $hab$  calories. Again if  $r$  is the resistance per unit length and  $i$  the required current the electrical energy =  $\frac{i^2 r \times 60}{4.18}$  cal. Equating we get

$$h = \frac{60}{4.18} \cdot \frac{i^2 r}{ab} \text{ cal. per mt.}$$

The bolometer devised by Langley has also been employed for the purpose.

**61. The Solar Constant.**—We have already defined the solar constant on page 351 and indicated the method of determining it. There we applied equation (1) to the total radiation though it is strictly true only for monochromatic radiation. Langley\* showed that the value of the solar constant determined in this way would be too low if some of the monochromatic radiations are entirely absorbed by the atmosphere. For an accurate determination of the solar constant, therefore, the following procedure has been found best by Abbot and his collaborators:—

Measurements are made with the spectrobolometer of the relative distribution of energy throughout the spectrum with different solar altitudes but as nearly as possible with constant sky conditions. At the same time the energy of the total radiation of the sun is measured by means of a pyrhelimeter. Each portion of the spectrobologram is extrapolated with the help of the Bouguer equation to zero atmosphere and thus the energy distribution curve outside the atmosphere is obtained. The areas between the base line (line of zero insolation) and the spectrobolograms, for both the actual and the extrapolated

\* See Humphreys, *Physics of the Air*, p. 83.

curves are found; let these be  $A$  and  $A_0$ . Then if  $I$  be the pyrhelimetric reading, the true solar constant  $I_0$  (the extrapolated value) is given by\*

$$I_0 = I \frac{A_0}{A} \quad \dots \quad \dots \quad (2)$$

According to the measurements made at the Smithsonian Institution since 1902, the mean values of the solar constant are as follows:—

$$\begin{aligned} 1902-1912 \dots 1.933 \text{ cal. cm.}^{-2} \text{ min.}^{-1} \\ 1912-1920 \dots 1.946 \text{ cal.} \quad \text{,,} \end{aligned}$$

If we compare the observed distribution of energy in the solar spectrum with the black-body curves at different temperatures we find great divergence. Plaskett finds that between  $\lambda = 3800$  and  $7600$  the radiation is identical with that given by a black-body at  $6700^\circ \text{A}$ . In other regions, however, it does not agree. It is, therefore, fairly certain that the radiation reaching us from the sun differs widely in quality from black-body radiation.

**62. Variation of Solar Constant or Solar Output.**—The solar constant has been found to vary by about  $\frac{1}{20}$ th of its mean value. It is not certain whether these variations are really due to variations in the solar radiation itself or are only due to variations in the composition and transparency of the atmosphere. It is possible, however, that these variations are connected in some way with sunspots which would presumably produce a change in the amount of total radiant energy emitted by the sun. In fact, Ångström in discussing the measurements made at Mount Wilson during the period 1915–17 found that the solar constant could be connected with the sunspots by the formula

$$I_0 = 1.903 + 0.011 \sqrt{N} - 0.0006 N$$

where  $N$  is a coefficient (known as Wolf and Wolfer's number) characterising the number and extent of sunspots. The meteorological influence of sunspots, however, has not yet been established with any certainty.

**63. Effective Radiation.**—From the point of view of meteorology it is not enough just to measure the energy sent out by the sun to a surface exposed normally to the radiation. Let us consider an element of area (1 sq. cm.) of the surface of the earth perfectly plane and horizontal and satisfying the conditions of an ideal black surface. The principal quantities of energy which it receives per unit time are the following:—(1)  $E_s$  coming directly from the sun, (2)  $E_a$  diffused by the atmosphere, and (3)  $E_a$  due to radiation by the atmosphere itself. On the other hand, the element itself must be emitting radiation and therefore losing a quantity of energy  $E_g$  per unit time. This energy is called *terrestrial radiation*. It must naturally depend on the nature of the

\* For fuller details of the method, the reader is referred to the original papers of the Smithsonian Institution and particularly to the work "The Solar Constant of Radiation" of G. G. Abbot.

substance covering the surface of the earth. In the absence of accurate data on this point, however, it is usual to attribute to the surface of the earth\* the properties of the ideal black body. If we neglect the exchanges of heat due to conduction and convection, then the gain of energy of the element under consideration is given by

$$H = E_s + E_d + E_a - E_g \quad \dots \quad \dots \quad (3)$$

The quantity  $H$  is called *effective radiation*. It becomes therefore necessary, in addition to pyrheliometric measurements, to measure either the effective radiation or the different terms separately which constitute the effective radiation. The instruments employed in these measurements are called *pyranometers*.

The theoretical study of the atmospheric radiation is rather complicated and need not be entered into here.† The experimental determination is comparatively easy specially during the night when diffuse radiation is almost negligible. The effective nocturnal radiation  $H$  is then given by

$$H = E_a - E_g$$

In this way  $E_a$  can be determined when  $H$  is measured and  $E_g$  known.  $E_g$  can be calculated from the temperature of the earth.  $E_a$  is about '28 cal. at 20° when there is no water vapour in the atmosphere.

**64.** For studying the phenomena of weather it is necessary to have some idea of the vertical and of the horizontal distribution of the three most important weather elements, namely, temperature, pressure and humidity. In the following sections, therefore, we shall describe the distribution of these elements under average conditions.

## V. DISTRIBUTION OF TEMPERATURE

**65. Vertical Distribution of Temperature.**—The results of aerological observations show that the temperature of the atmosphere decreases as the altitude increases. By combining several observations made above a given region, the form of the curve giving the variation of temperature with altitude is determined. This curve varies slightly with the season, particularly at the lower levels. Figure‡ 21 gives the vertical distribution of the monthly mean temperatures over Agra

\* Some people have attributed to the earth's surface the properties of the so-called *gray body*.

† The inquisitive reader may consult the papers of A. Ångström.

‡ Taken from Chatterjee and Sur's paper "Thermal Structure of Free Atmosphere over Agra." *Gerlands Beiträge Zur Geophysik*, Vol. 25, p. 266 (1930).

(lat. 27° 10' N, long. 78° 5' E.) in the United Provinces of Agra and Oudh, India.

The fall of temperature due to a rise of 100 metres is usually called the vertical gradient of temperature and the fall of temperature per kilometre rise in altitude is usually known as the *lapse-rate* of temperature. The lapse-rate over any particular region varies with altitude, and there is also a seasonal variation. Figure 22\* represents the variation of the mean lapse-rate with height in different seasons over Agra.

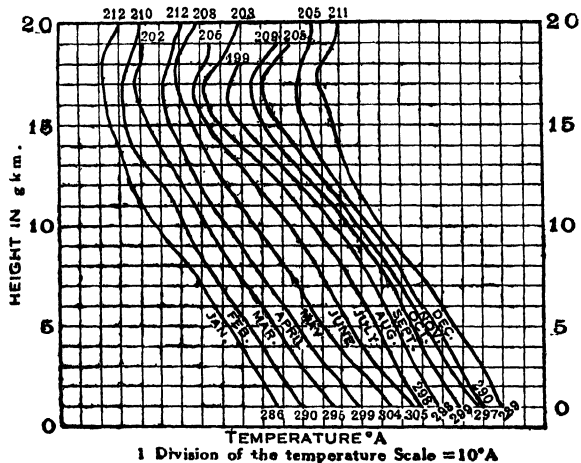

Fig. 21.—Vertical distribution of monthly mean temperatures over Agra.

Meteorologically, the year in India can be conveniently divided into five seasons:—

1. Winter—November to February.
2. Early hot season — March and April. (Spring)
3. Later hot season or pre-monsoon period—May and June. (Summer)
4. Monsoon season — July and August. (Rains)
5. Post-monsoon period — September and October. (Autumn)

During the winter there is generally a layer of well-marked maximum lapse-rate between 1 and 1.5 gkm.† The mean lapse-rate above 4 gkm. slowly increases with height reaching a feeble maximum between 7 and 8 gkm., and then slowly decreases up to 13 gkm. after which the decrease is

\* Taken from K R. Ramanathan's discussion in the "Memoirs of the Indian Meteorological Department," Vol. XXV, part V (1930), pp 163 193.

† 'Gkm' means geodynamic kilometre = 1000 times the unit of geopotential, *i.e.*, the dynamic metre. This latter is equal to the potential energy gained by a body of unit mass (1 gram) which is moved through a distance of one metre in a field of 1000 dynes, *i.e.*, dynamic metre =  $10^5$  C. G. S. units Thus a geodynamic kilometre =  $\frac{1000}{g}$  times the ordinary kilometre, and hence the value of a gkm, when expressed in ordinary kilometres varies with latitude depending upon the value of  $g$ ,

rapid. In the early hot season, and particularly in April, the mean lapse-rates are markedly higher up to 4 gkm. than at higher levels. There is a feeble minimum of  $6.5^{\circ}\text{C}$  per gkm. between 4 and 5 gkm. Between 4 and 11 gkm. the curve is similar to that of the winter curve. The marked decrease in lapse-rate becomes manifest only above 15 gkm. The curve for the pre-monsoon period is characterised by two maxima, one going up to  $9^{\circ}\text{C}/\text{gkm}$ . between 1.5 and 3 gkm, and the other to  $8^{\circ}\text{C}/\text{gkm}$ . between 11 and 12 gkm. There is a minimum of  $5.5^{\circ}\text{C}/\text{gkm}$ . between 6 and 7 gkm. A marked decrease which is sharper than in the previous seasons, manifests itself only above 16 gkm.

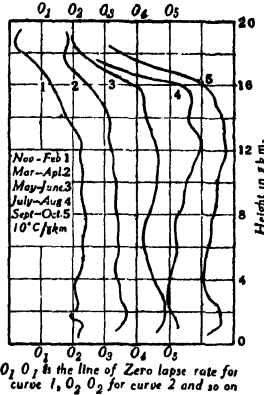

Fig. 22. - Variation of mean lapse-rate with height over Agra in different seasons.

The post-monsoon period is intermediate in character between that for the pre-monsoon and that for the monsoon period. The two maxima occur between 1 and 2 gkm. and between 11 and 14 gkm. The minimum occurs between 3 and 5 gkm. while the decrease of lapse-rate above 14 gkm. is more gradual than during the monsoon season.

The causes of the diminution of temperature with height in the atmosphere are manifold, but we may broadly explain here why the temperature falls as we go up in the atmosphere up to a height of about 8 km. in the temperate zones and about 15 km. in the tropics, and afterwards becomes constant. Much of the incident solar radiation (about 50%) is transmitted by the atmosphere to the earth while only a small part is absorbed by it. The energy absorbed by the atmosphere is distributed over such a large mass of air that the latter is not at all appreciably heated by incident radiation. In contrast to this, however, the energy received by the earth is concentrated and therefore heats its surface considerably. The heated surface in turn warms the air above it, partly by contact and partly by the long-wavelength radiation emitted by it and absorbed by the air. Now the temperature of air at any height depends upon the total energy absorbed and emitted by it. The lower atmosphere at ordinary temperatures emits more energy than it absorbs, and therefore tends to cool by radiation. These two phenomena, the heating of the earth and the cooling of the layer above so affect the density of the atmosphere as to cause vertical convection in consequence of which the warm ascending air becomes cooled through adiabatic expansion\* and the descending air becomes heated by adiabatic compression. In this way the decrease of temperature with increase of elevation is established and maintained throughout the region in which vertical convection takes place. An expression giving the decrease in temperature with altitude is deduced on page 425.

\* This is because the pressure of the atmosphere decreases with elevation.

Above a certain height, however, convection becomes feeble and the temperature of the atmosphere falls so much that the heat emitted by it becomes equal to the amount absorbed by it. (This is because the heat received by the air from the earth remains practically constant at all available altitudes). In that case the temperature of the layer remains always the same at and above this height and therefore there will be no convection currents above this height. This region is called the stratosphere and is described fully in the next section.

**66. Troposphere and Stratosphere.**—From Figure 22 it is evident that over Agra there is a certain height, varying from 13 to 16 gkm. where there is a rapid decrease in the lapse-rate, and at about 20 gkm. the lapse-rate becomes zero. A similar discontinuity in the vertical distribution of temperature in the atmosphere is noticed all over the world, although the height at which it occurs is not the same everywhere. The outer shell of the atmosphere, in which the temperature remains practically constant with variation of height, is given the special name of *Stratosphere\** or *Advective Zone* to distinguish it from the *Troposphere* or *Convective Zone*, which is the lower portion in which the lapse-rate is considerable. The surface of separation of these two regions of the atmosphere, which plays a very important rôle in the modern theories of atmospheric circulation, is called the *tropopause*. The height of the tropopause varies with the latitude. This tropopause seems to lower towards the ground as we proceed from the equator to the poles, its height being about 14 km. at the equator and about 8 to 10 km. at the poles. This naturally means that the thickness of the troposphere decreases as we proceed from the equator to the pole. Longitude, on the other hand, seems to have no effect at all on the height of the tropopause. Besides, over the same region the thickness of the troposphere is greater in

\* These names were suggested by Teisserenc de Bort as early as 1899. The stratosphere is also called the *isothermal layer*. The vertical movement of air in this layer is very small or nil. This is the reason why even the formidable columns of smoke and dust which are thrown up into the atmosphere during volcanic eruptions cannot rise above the level of the tropopause, but are just spread out laterally at this level. Only by the eruption of Krakatoa in 1883, the tropopause seems to have been broken through. The stratosphere also seems to have a structure, the different layers gliding horizontally one over the other without mixing. The thickness of the stratosphere is not yet known.

summer than in winter (the variation in height being proportional to that in surface temperatures); and during the same season it is smaller when the pressure is low than when the pressure is high.

In the north-western parts of Europe the altitude of the tropopause is about 11·5 km. in winter and 12 km. in summer. Up to about 30 km. the greatest height up to which sufficient data are available, the temperature of the stratosphere remains practically constant during winter, while during summer it has a slight tendency to rise. Besides, the temperature of the stratosphere decreases from the poles to the equator; it is  $-45^{\circ}$  to  $-50^{\circ}$  over Lapland,  $-55^{\circ}$  over Central Europe, and  $-75^{\circ}$  to  $-80^{\circ}$  over the tropical regions.

The various facts mentioned above can be roughly explained on the basis of the explanation put forward in the last section. All causes which affect the intensity of the exchange of air by convection or turbulence, should influence the temperature gradient of the troposphere. A higher temperature of the layers of the atmosphere near the surface of the earth should correspond to a greater thickness of the troposphere. Low pressures which are generally accompanied with strong winds, should be characterised by a higher lapse-rate than high pressures, which are often accompanied by weak or no winds. This difference should naturally be more marked in the lower layers, which are specially affected by atmospheric disturbances. These conclusions are in agreement with the observed data.

**67. Physical Explanation of the Existence of the Stratosphere.**— Since the discovery of the stratosphere by Teisserenc de Bort\* and Assmann many physical explanations of the existence of the isothermal region have been proposed, but for a number of years all the explanations proved unsatisfactory. In 1909 † Gold and Humphreys independently and almost simultaneously put forward the explanation which accounts for the general features of the phenomena. The essential idea underlying the explanation has been mentioned on page 410. We shall here further develop the idea and calculate quantitatively with its aid the temperature of the isothermal region. According to the theory of Gold and Humphreys the stratosphere is in radiative equilibrium in contrast to the troposphere which is in convective equilibrium.

We have already said that the effect produced in the air by the absorption of solar radiation is very small. We may therefore as a first approximation consider only the radiation emitted by the earth.

Let us now visualise the problem in the following two stages:—

(1) Imagine a thin layer of the stratosphere bounded by two infinite horizontal parallel plates at the same absolute temperature  $T_1$  and

\* *Compt. Rend.*, Vol. 134, p. 987 (1902).

† Gold, *Proc. Roy. Soc.*, Vol. 82, p. 43 (1909); Humphreys, *Astrophys. Journ.*, Vol. 29, p. 14 (1909). See also Emden, *Sitzb. k. Bayr. Akad. Wiss.*, p. 55 (1913); and Milne, *Phil. Mag.*, Vol. 44, p. 872 (1922); Hergessel, *Wiss. Abh. Preuss. Aero. Observ.* Lindenberg, Vol. 13, 1919; Simpson, *Memoir Roy. Met. Soc.*, Vol. 3, No. 21.

separated by a distance small in comparison with their width. Since the space is practically enclosed it follows from thermodynamical considerations (p. 327) that the stratosphere must also have the same temperature  $T_1$ . Then for radiative equilibrium we must have

$$e_1 = 2\epsilon a$$

where  $e_1$  is the emissive power of the stratosphere,  $a$  its absorptive power and  $\epsilon$  the energy received per second by the stratosphere from one of the plates.

(2) Now let the upper plate be removed so that the stratosphere can radiate freely into the interstellar space. So far as exposure to radiation is concerned, this layer of the stratosphere is essentially in the same condition as the upper atmosphere in its exposure to the lower atmosphere. The problem therefore reduces to finding the final temperature  $T_2$  which the layer will assume in this state. If the lower plate is constantly maintained at the same temperature  $T_1$  (in the actual case the earth is maintained at a constant temperature by solar radiation for we find that the mean temperature of the earth remains constant from year to year), then for radiative equilibrium we have

$$e_2 = \epsilon a^*$$

where  $\epsilon$  is the same as in the previous case so that

$$\frac{e_1}{e_2} = 2 \quad \dots \quad \dots \quad (4)$$

We have now to find how the radiation emitted by the stratosphere varies with temperature. Since the radiation from the stratosphere may be assumed to be purely thermal it will be in full accordance with Kirchhoff's law (p. 324), that is for every temperature and wavelength

$$\frac{e_\lambda}{a_\lambda} = E_\lambda$$

where  $E_\lambda$  is the emissive power of a perfectly blackbody. Now since the absorptive power  $a_\lambda$  does not vary much with slight changes in temperature as long as the composition of the stratosphere is unaltered, we shall have for the two temperatures  $T_1, T_2$

$$\left( \frac{e_\lambda}{E_\lambda} \right)_{T_1} = \left( \frac{e_\lambda}{E_\lambda} \right)_{T_2}$$

$$\text{or } \frac{e_{\lambda, T_1}}{e_{\lambda, T_2}} = \frac{E_{\lambda, T_1}}{E_{\lambda, T_2}}$$

The spectral distribution of energy for the stratosphere is not known; it is probably more or less continuous. If, therefore, we that for small changes of temperature the increase of radiation wavelength is proportional to the increase in total radiator to a rough first approximation for a blackbody, we get

$$\frac{e_1}{e_2} = \frac{E_1}{E_2} \quad \dots \quad \dots$$

where the symbols now stand for total radiation.

\* This is the case so

ries ve wa



Now from Stefan's law

$$\frac{E_1}{E_2} = \frac{T_1^4}{T_2^4} \quad \dots \quad \dots \quad \dots \quad (6)$$

Combining (4), (5) and (6) we get

$$\frac{T_1^4}{T_2^4} = 2$$

or 
$$T_1 = T_2 \sqrt[4]{2} = \frac{119}{100} T_2$$

If we put  $259^\circ\text{A}$  ( $-14^\circ\text{C}$ ) for  $T_1$  we get

$$T_2 = 218^\circ\text{A} = -55^\circ\text{C}.$$

This is actually the temperature of the stratosphere over the temperate zone.

A word must be said about the choice of the value  $259^\circ\text{A}$  for  $T_1$ . This temperature actually exists in the atmosphere at the level of the alto-cumulus clouds, *i.e.*, about 4300 metres. This level is usually taken as the mean starting point of earth radiation, because when the earth is covered with clouds the radiation (consisting of long waves) proceeds outward from the clouds and not from the surface of the earth. In spite of the approximate nature of the above calculations it is clear that the isotherm of the stratosphere is the result of radiative equilibrium.

**68. Inversions**—Apart from the more or less regular vertical distribution of temperature, which we have just described, there are often sudden discontinuities in temperature distribution in the lower levels of the atmosphere. In ideal cases these discontinuities can be extremely sharp, and even attended with a rise of temperature with height. Such cases of abnormal distribution of temperature are known as *inversions*.

In ordinary cases, however, the discontinuity is not so sharp and the inversion occurs throughout a layer rather than over a surface. These layers vary in thickness, but generally are several hundred metres thick.

**69. Distribution of Temperature over the Globe.**—As we have remarked before, the ultimate cause of all meteorological phenomena is the heat received from the sun. The most obvious manifestation of this heat is in the distribution of temperature on the surface of the earth and its variation with height. In meteorology the most commonly measured temperature is the surface temperature of the air near the earth's surface. The instruments employed for this purpose have already been described in sections 4 to 10.

The observations made at meteorological stations are usually of the surface air near the earth's surface.

the surface at every station undergoes two kinds of regular variations, namely *diurnal* and *annual*. These variations are naturally not the same at all places. The distribution of temperature on the surface of the earth depends on (a) the distribution of solar heat, the annual total insolation decreasing from the equator towards the poles, on (b) the exchange of air between higher and lower altitudes due to the difference in temperature, on (c) the distribution of land and sea and on (d) ocean currents.

**70. Annual Variations.**—In spite of the many complications it is possible to calculate from actual observations the annual average temperature at a given latitude taking into consideration the influence of land and sea. The normal annual (or monthly) temperatures are calculated from the daily average temperatures of stations all over the world. The daily average temperature of a station must be calculated from data extending over a large number of years in order to eliminate the diurnal variation of temperature which occurs at every station. It is found that in equatorial regions the annual variation of temperature shows two maxima and two minima (Fig. 23 curve B, which gives the annual variation of temperature at Batavia). This curve is exactly analogous to curve 1 (Fig. 20) but the positions of the maxima and the minima do not quite agree. We see from the curve that while the solar insolation has begun to decrease the temperature is still rising; this rise of temperature continues as long as the gain of heat during a certain time is greater than the amount of heat lost. A similar lag also occurs in the positions of the minima.

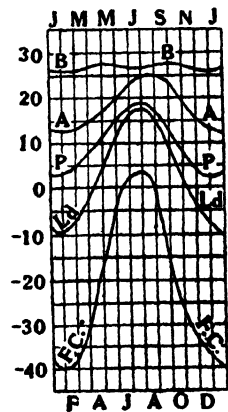

Fig. 23.—Annual variation of temperature at different latitudes

Like the variation of insolation the annual variation of temperature outside the tropical regions shows only one maximum in summer and one minimum in winter. On the average the maximum occurs about the

15th January, so that the maximum and the minimum of temperature occur about 20 days later than the maximum and the minimum of insolation. At the time of the summer solstice the quantity of heat received is practically constant over a large range of latitudes but the further we go towards the north, the less is the heat received in winter. The amplitude of annual variations of temperature should therefore increase with the latitude and this increase would result more from the progressive lowering of temperature in winter than the variation of temperature in summer. These conclusions are well borne out by the curves A, P and Ld. (Fig. 23) which correspond to Algiers, Paris and Leningrad respectively.

Beyond the polar circles there is a season when the sun never rises above the horizon, so that the temperature continues to decrease till the sun rises above the horizon again. In winter, therefore, the nearer we approach the pole, the lower is the temperature, the amplitude of annual variation increases and the period of minimum recedes. This is seen clearly from the curve FC (Fig. 23) which gives the observations made at Fort Conger in the north-west of Greenland. The minimum of temperature at the pole itself occurs about the 20th of March.

**71. Isothermal Charts.**—The best way of picturing the distribution of temperature over the earth is by means of isothermal charts. The normal monthly and annual temperatures are found out as in the previous section. For the sake of comparison they must be reduced to a common

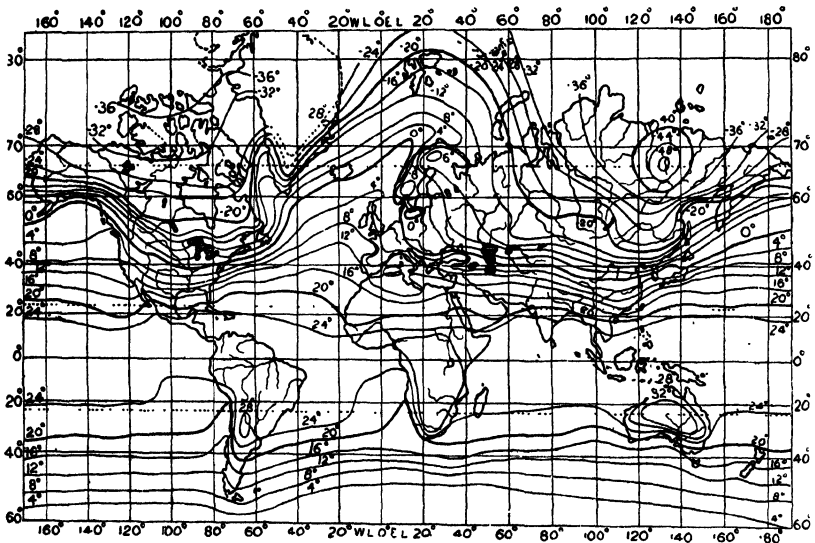

Fig. 24.—Isotherms of January.

level, the mean sea-level being chosen. These temperatures are charted on a map and lines drawn through those places which have the same temperature. These lines are usually called *isotherms*. According as the chart is made with monthly or annual normal temperatures it is called the

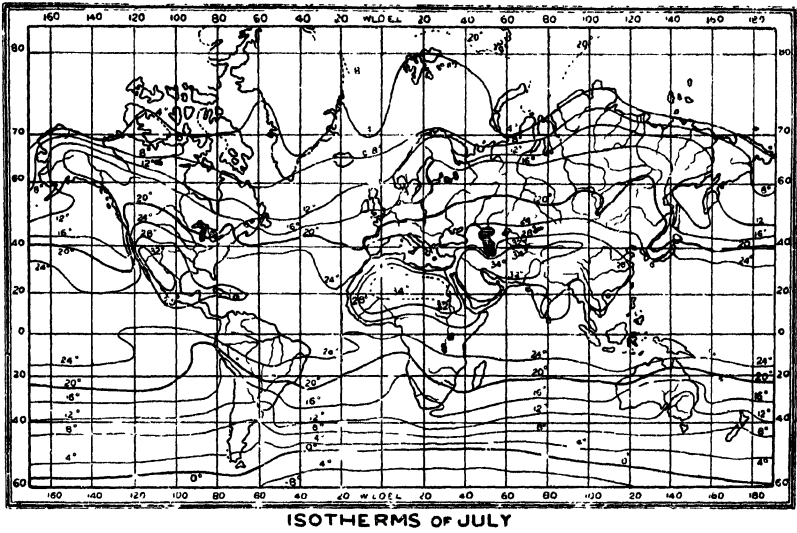

Fig. 25

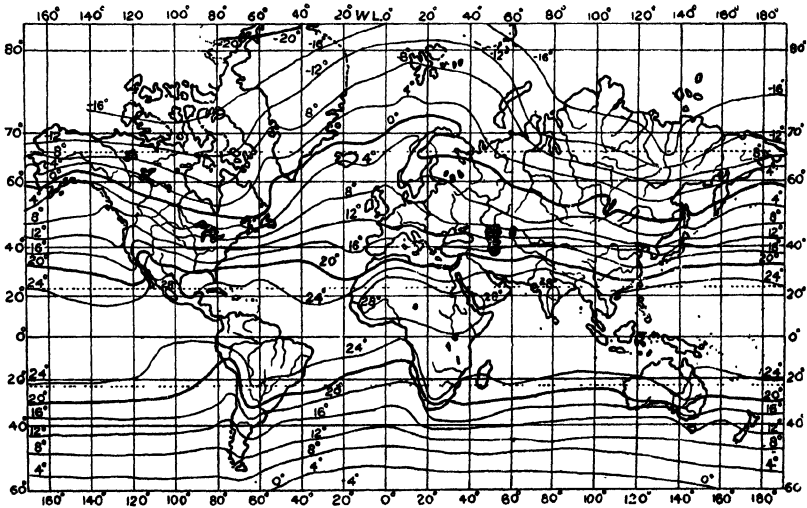

Fig. 26.—Annual Isotherms.

monthly or annual isothermal chart. The isotherms of January, July and of the year are represented in Figs. 24, 25 and 26 respectively. One would expect that all places on the same parallel of latitude would have the same temperature and that the isotherms would be parallel to the parallels of latitude. This, however, is by no means the case, as is clear from the isothermal charts. The chief cause of this deflection is the existence of ocean currents.\*

An important feature of the isothermal charts, which one cannot fail to notice, is that the central line of the hot belt lies, on the whole, north of the geographical equator. If we determine for each meridian the point at which the temperature is the highest and join all these points by a line, we get the line of highest temperature which is known as the *thermal equator*. The thermal equator is not however an isotherm; it passes through 26° in the Pacific and more than 30° in Africa. On the oceans the thermal equator approaches the geographical equator and even descends slightly to its south in the middle of the Pacific. On the other hand, the thermal equator goes far up into the northern hemisphere over the continental regions where for the same latitude the temperatures are higher than on the seas. It reaches the latitude 20° over Mexico, India and goes even higher over the Sahara. We shall see later what influence the thermal equator exerts on meteorological phenomena, particularly on the general circulation of the atmosphere.

It follows from the position of the thermal equator that in the equatorial regions the northern hemisphere is warmer than the southern hemisphere. This is evident because the southern hemisphere is largely a water hemisphere while the northern hemisphere is largely a land surface and because for the same latitude up to latitude 45° on either side of the geographical equator the land is on the average warmer than the sea. Beyond 45° however the conditions become reversed, the average temperature of the sea is higher than that of the land. At latitudes higher than 45°, therefore, the southern hemisphere would be warmer than the northern; this conclusion is borne out by the isothermal charts. It must be mentioned, however, that recent observations made in the Antarctic regions show that in the neighbourhood of the poles the southern hemisphere is colder than the northern. This reversal is due to the existence of a big continent around the south pole. Table 6 due to Hann and Meinardus† gives the distribution of temperature and of land for different latitudes. From this table we find that the average temperatures of the two hemispheres and of the whole earth for the two months, January and July, representative of the extreme seasons and for the year, are as follows:—

	Jan.	July	Year
N. Hemisphere	8·1	22·4	15·2
S. Hemisphere	17·0	9·7	13·3
Whole Earth	12·5	16·1	14·2

Some interesting points may be noted. In summer the north pole is the coldest part of the northern hemisphere, though the insolation received

\* A. Defant's *Ozeanographie* may be referred to in this connection

† See Müller-Pouillet, *Physik der Erde und des Kosmos*.

there is large. This is because the polar regions are covered with snow which reflect back from 30 to 40 per cent of the insolation and further the

*Table 6.—Mean temperatures at different latitudes on the earth's surface.*

Latitude	North Hemisphere				South Hemisphere			
	Jan.	July	Year	Land	Jan.	July	Year	Land
Pole	-41.0	-1.0	-22.5	?	-11.0	-42.0	-30.0	100
80	-32.2	2.0	-18.1	0.22	-7.4	-36.0	-24.7	?
70	-26.3	7.3	-10.7	0.40	-1.3	-23.9	-13.3	?
60	-16.1	14.1	-1.1	0.52	1.2	-10.3	-4.1	0
50	-7.0	18.1	5.8	0.53	8.3	2.9	5.6	0.02
40	4.9	24.0	14.0	0.47	15.5	9.0	12.0	0.09
30	14.6	27.3	20.3	0.40	21.8	14.6	18.4	0.16
20	21.9	28.3	25.2	0.32	25.4	20.9	23.0	0.20
10	25.8	26.9	26.7	0.25	26.3	23.9	25.3	0.21
Equator	26.4	25.6	26.2	0.22	26.4	25.6	26.2	0.22

temperature cannot rise much above 0°C. because a large amount of heat is required for melting the ice. In winter, however, the north central Siberia is the coldest part in northern hemisphere and in summer the north part of Africa is the hottest. This is because water currents from the equator to the pole warm the latter but cannot reach Siberia; further the pole is largely a water surface and is not capable of those extremes of climate which the land in Siberia acquires. The lowest temperature yet observed on the earth's surface is -69.8°C. at Verchojansk in north central Siberia in 1885 and the highest temperature was 53°C. at Ouargla in Algeria in 1879.

**72. Diurnal Variation of Temperature.**—In order to find out if there is any regularity in the daily variation of temperature, it is necessary to eliminate perturbations. This is done by taking the monthly mean of temperatures for the different hours of the day. For illustration, the diurnal variation of temperature at Alipore (Calcutta) is represented in Fig. 27. The curve is found to possess the following characteristics:—

The temperature begins to rise immediately after sunrise and goes on rising till about 14 hours, when the maximum is generally reached. It then begins to decrease

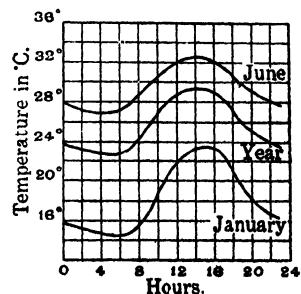

Fig. 27.—Diurnal variation of temperature at Alipore.

and goes on decreasing during the whole night till slightly after sunrise when the minimum is reached. The maximum and the minimum must occur at the moments when there is exact balance between gain and loss of heat, so that it is evident why the maximum occurs sometime after noon and the minimum slightly after sunrise.

**73. Variation with Latitude.**—Since the diurnal variation of temperature at any place depends on the quantity of heat received from the sun, it is obvious that it must depend on the seasons and on the latitude. At the equator the insolation varies very slightly from one season to another, and also the days and nights have always the same duration; consequently the amplitude of diurnal variation is practically constant throughout the whole year. At Batavia, for example, the amplitude of diurnal variation does not vary more than 3° during the year, the minimum amplitude being 45° in January and February and the maximum 74° in August.

In temperate regions the amplitude undergoes large variations with the season. It is larger in summer than in winter when the insolation is less and the nocturnal radiation is also less. The amplitude of diurnal oscillation of temperature at Paris, for example, is larger in July than in January.

Within the polar circle the duration of night in winter is about 41 days at latitude 68° N, 61 days at 70° N, 103 days at 75° N and 131 days at 80° N. During this time the temperature undergoes no regular diurnal variation. In summer, on the other hand, the sun never sets, but the height of the sun above the horizon varies and consequently there is a diurnal variation of temperature. The maximum occurs between 14 hours and 15 hours as in other regions, but the minimum occurs between 1 h. and 2 h., *i.e.*, slightly after the sun has attained its lowest level. At the pole itself there is no proper diurnal variation in the altitude of the sun and consequently no diurnal variation of temperature.

Thus the amplitude of the diurnal variation of temperature ought to increase from the poles to the equator, but in addition to the factors considered above there are other causes which influence the diurnal variation of temperature, for example, cloudiness, geographical conditions, altitude, etc. The amplitude of diurnal variation at a place should be less when the sky is clouded than when it is clear; it should depend on the nature of the surface of the earth at the place under consideration, for example, it should be much smaller on sea than on land. In the continental regions too the amplitude of diurnal variation of temperature will depend on the nature of the soil; it should be very large in deserts and much smaller on land covered with vegetation. Topographic conditions also have a great effect.

**74. Influence of Altitude on Diurnal Variation of Temperature.**—The diurnal variation of air temperature depends principally on the diurnal variation of the temperature of the soil. With increase of altitude above the ground, therefore, there should be a decrease in the

amplitude of diurnal variation of air temperature. This effect has been actually observed on high towers, such as the Eiffel tower of Paris, and on mountains, in spite of the appreciable influence of the mass of the mountains themselves; at Darjeeling, for example, the amplitude of diurnal oscillation is  $7.1^{\circ}$  in December and  $5.5^{\circ}$  in June, while at Jalpaiguri (which is at the foot of the hills) it is  $12.7^{\circ}$  in December and  $7.4^{\circ}$  in June. On plains or on plateaux the changes are in the opposite direction; the amplitude of diurnal oscillation is higher at the higher station because the air is rarer and drier and therefore absorbs less of the insolation and of the nocturnal radiation. Thus in Central Asia on the high plateaux of Pamir and of Tibet the diurnal variation of temperature often exceeds  $25^{\circ}$  in summer.

## VI DISTRIBUTION OF PRESSURE

**75. Vertical Distribution of Pressure.**—The theory of the diminution of pressure with increase of altitude is based on the application of the ideal gas laws to the atmosphere, so that it is necessary to distinguish between the decrease of pressure in the troposphere and that in the stratosphere. Let us suppose that the former is in convective or adiabatic equilibrium and the latter in isothermal or radiative equilibrium. On account of turbulence and convection the composition of the air in the troposphere is practically the same at all heights so that for the theoretical calculation of the vertical pressure gradient it is sufficient to assume a mean gas constant for the atmospheric air considered as a uniform gas. The case is however quite different for the stratosphere where if the existence of isothermal conditions be postulated, the possibility of vertical convection should be excluded. Here the different gases of the atmosphere must arrange themselves in order of their densities so that lighter gases must predominate in the higher layers. In this case, therefore, the assumption of an average gas constant for all the different gases is not justified and we have to treat each constituent separately with its proper gas constant. We shall first find an expression for the vertical diminution of pressure in the *troposphere*.

Let  $-dp$  be the decrease of pressure corresponding to an increase of elevation  $dz$ . Then if  $\rho$  is the density of air at the point under consideration we have, on equating the decrease of pressure to the weight of the air column  $dz$ ,

$$-dp = g\rho dz \quad \dots \quad (7)$$

If  $t^{\circ}\text{C.}$  denote the temperature of the air column and  $\rho_0$  the density of the



column at  $0^{\circ}\text{C}$ ., and pressure  $p_0$  prevailing at the earth's surface,  $\alpha$  the coefficient of expansion of air at constant pressure, we get from Boyle's and Charles' laws,

$$\rho(1+\alpha t) = \frac{p_0}{\rho_0}$$

$$\text{or } \rho = \frac{p_0}{\rho_0} \frac{1}{1+\alpha t} \quad \dots \quad \dots \quad \dots \quad (8)$$

Combining (7) and (8) we get

$$\frac{dp}{p} = - \frac{\rho_0}{\rho_0} \frac{g dz}{1+\alpha t}$$

Integrating we get

$$\log_e \frac{p}{p_0} = - \frac{\rho_0}{\rho_0} \frac{g z}{1+\alpha t}$$

$$\text{or } p = p_0 e^{-\frac{\rho_0 g z}{\rho_0 (1+\alpha t)}} \quad \dots \quad \dots \quad (9)$$

This is known as Laplace's formula. It is evident that this formula can be used for calculating the difference in height between two stations when the barometric pressures at the two stations are known. For this purpose the formula may be put in a more convenient form, *viz.*,

$$h = \frac{p_0 (1+\alpha t)}{\rho_0 g} \times \log_e \frac{p_0}{p}$$

$$= \frac{1.01 \times 10^7 \times 2.3}{100129 \times 980} \times (1+\alpha t) \log_{10} \frac{p_0}{p} \text{ cms.}$$

$$= 18400 (1+\alpha t) \log_{10} \frac{p_0}{p} \text{ metres} \quad \dots \quad (10)$$

Besides the above, there is a second application very important to the meteorologist, namely, the *reduction of pressure to the sea-level*. It must be noted, however, that the problem of reducing pressures to the sea-level or of calculating the difference of height of two stations is not determinate without a knowledge of the temperature of the air column. In the above formula the temperature of the air column is supposed to be constant, which is far from being the case. We have, therefore, to satisfy ourselves with using the mean temperature

of the air column comprised between the two stations, the difference between whose heights is to be calculated. Further we have neglected the variation of  $g$  and of the water content of the atmosphere with altitude.\*

In case of the reduction of pressures to the sea-level it must be observed that the lower station (the sea-level) has no real existence, so that only the temperature of the upper station is known. It is, therefore, necessary to assume a certain law of variation of temperature between the station under consideration and the sea-level. A common practice is to assume† a rise of 1°C. for a descent of 200 metres. This assumption naturally involves a certain amount of uncertainty in the calculated results. So long as the altitude of the station is lower than 500 metres, the uncertainty in the value of the pressure reduced to the sea-level hardly exceeds 0.1 mm. and is therefore negligible. But from 700 metres upwards the reduction to sea-level becomes very uncertain so that, for comparing the pressures of all stations at very high altitudes, the reduction is made to a height of 1000 m., 1500 m., or 2000 m. according to convenience.

Finally, it is to be noted that in the deduction of Laplace's formula the air is supposed to be at rest. If the air happens to depart from statical equilibrium in the vertical direction, errors will be introduced in the reduced values but these errors are not likely to be very large, since even the horizontal gradients of pressure between stations at a distance equal to the height of the atmosphere are small.

**76. Distribution of Pressure in the Stratosphere.**—In this case of isothermal equilibrium as mentioned above, we must consider each gas separately. Then as before

$$- dp = g\rho dh$$

where  $p$  denotes the partial pressure of one constituent, and  $\rho$  its density.

Now, since  $p = \frac{RT\rho}{M}$  we have

$$-\frac{d\rho}{\rho} = \frac{Mg}{RT} dh$$

whence on integrating

$$\rho \dagger = \rho_0 e^{-\frac{mgh}{kT}} \dots \dots (11)$$

Similarly, for the other constituents

$$\rho' = \rho_0' e^{-m'g'l/kT}; \rho'' = \rho_0'' e^{-m''hg/kT}$$

etc.      etc.

\* For a formula taking into account all these factors, see Humphreys, *Physics of the Air*, pp. 62-67.

† This is deduced in Sec. 77.

‡ This can be directly deduced from Maxwell's law (p. 102)  $n = n_0 e^{-E/kT}$  for here  $E = mgh$ .

where  $\rho_0, \rho_0', \rho_0'' \dots$  denote the densities of the different gases in the tropopause,\*  $m, m', m'' \dots$  the masses of their molecules. We have neglected the variation in the value of  $g$  and also the rotation of the earth. From the above equations the densities of the constituents of the atmosphere at different heights can be calculated, and hence also the partial pressures. In this way the decrease of pressure with height can be calculated for

$$\log_{10} \frac{\rho_0}{\rho} = (h-h_0) \frac{mg}{kT \times 2.30} \dots \dots (12)$$

It is with the help of formulæ (9) and (12) that Table 2 on p. 398 was calculated. It will be easily seen from (12) that the density of each gas constituting the atmosphere falls off exponentially with the height above the earth's surface.

**77. Convective or Adiabatic Equilibrium.**—Equation (9) was deduced for the troposphere at rest. In reality, however, the troposphere is incessantly being agitated by currents and storms so that there is continual mechanical transference of air from one part of the atmosphere to another. Now the conduction of heat in gases is extremely slow so that the atmosphere can never come to the isothermal state through conduction. The factor which determines the distribution of the atmosphere is not the equalisation of temperature, but the condition that a given mass of gas, on being moved from one place to another, shall take up the requisite volume and pressure in its new position without any loss or gain of heat by conduction. The law connecting the volume and pressure in the troposphere should on such assumption approximate to the adiabatic law.

The general equation of equilibrium of the atmosphere is

$$\frac{dp}{dz} = -g\rho \dots \dots (7)$$

and if the adiabatic law  $p = k\rho^\gamma$  holds for the atmosphere, we have

$$k \gamma \rho^{\gamma-1} \frac{d\rho}{dz} = -g\rho$$

\* As the height of the tropopause is small we may consider these quantities to represent at the earth's surface,

Integrating this, we get

$$\frac{k\gamma}{\gamma-1} \left( \rho_0^{\gamma-1} - \rho^{\gamma-1} \right) = g z \dots \dots (13)$$

where  $\rho_0$  is the density at zero level. This is the law according to which the density falls off with increase in height in the troposphere. Since  $T$  the absolute temperature is proportional to  $\rho^{\gamma-1}$  (equation 24, p. 59) this law can also be expressed as\*

$$\frac{T_0 - T}{z} = \frac{g}{J c_p} = \frac{1}{10293} \dots (14)$$

where  $T_0$  is the temperature at height zero,  $J$  the mechanical equivalent and  $c_p$  the specific heat at constant pressure. Thus the temperature decreases proportionally to the increase of height as we go upwards in the atmosphere. Substituting numerical values we find that the constant of the above equation is about  $10^\circ\text{C}$ . per kilometre. This value is about twice the experimentally observed temperature gradient,† namely,  $5^\circ\text{C}$ . per km.

Since the troposphere is approximately in convective equilibrium and the processes of diffusion and conduction are slow in gases, the constituents of the atmosphere should occur in approximately the same proportion at all heights, as has also been found experimentally by Frankland.‡ And if the stratosphere did not exist and the whole atmosphere were in convective equilibrium there would have been a superior limit to the height of the atmosphere, *viz.*, about 29 kilometres. As things are, however, equation (11) shows that there can be no upper limit to the height of the outer atmosphere in isothermal equilibrium. But it must be remembered that these equations involve the assumption that the earth does not rotate and there is no variation in the value of gravity. If the height of the atmosphere is found to be infinite, this assumption becomes inadmissible. If the rotation of the earth is taken into account it can be shown that the density of the stratosphere decreases as we pass outward till it reaches a minimum and then increases. But for want of space we cannot go into a detailed consideration of this question.

\* This could be obtained more readily by using equation (25), p. 59, in place of equation (23).

† See Dines, *Phil. Trans.*, Vol. 211, p. 253 (1912); Gold, *Proc. Roy. Soc.*, Vol. 82, p. 43 (1909). The rate of  $1^\circ$  per 200 metres has been adopted by the *Comité Météorologique International* for reductions of temperature observations to sea-level.

‡ *Journ. Chem. Soc.*, Vol. 13, p. 22,

**78. Diurnal Variation of Pressure on the Earth's Surface** — If we observe the barometer carefully from hour to hour at any place under normal conditions we notice that the atmospheric pressure varies from hour to hour. If the irregularity due to accidental causes be

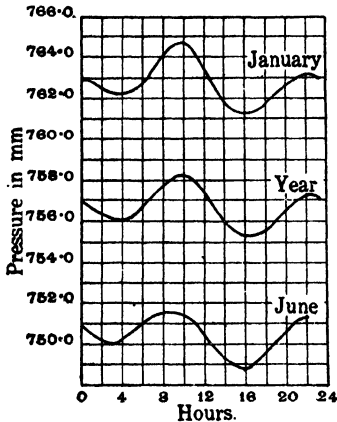

Fig. 28.— Diurnal variation of pressure at Alipore.

eliminated by taking the hourly averages of a long series of measurements, we find that the pressure undergoes a systematic diurnal variation characterised by a double oscillation. The pressure rises from 4 h. to 10 h., falls from 10 h. to 16 h., rises again till about 22 h. and falls again from 22 h. to 4 h. The average diurnal variation of pressure at Alipore (Calcutta) is represented in Fig. 28.

**79. Variation with Latitude.—**

The amplitude of diurnal variation of pressure varies from place to place depending upon the latitude. It is large at the equator and diminishes as we proceed northwards or southwards towards the poles. Fig. 29 gives the curves of diurnal variation for the month of April at five stations situated in different latitudes. At Singapore (lat.  $1^{\circ}$ ) the mean amplitude (*i.e.*, the mean of the diurnal and nocturnal amplitudes) is slightly larger than 2.2 mm.; at Bombay (lat.  $19^{\circ}$ ) it is between 2.0 mm. and 2.1 mm.; at Lisbon (lat.  $39^{\circ}$ ) it is 0.9 mm.; at Paris (lat.  $49^{\circ}$ ) 0.7 mm. and at Upsala (lat.  $60^{\circ}$ ) it is only 0.3 mm. The large normal diurnal variation of pressure in the tropics must be borne in mind in watching a depression or cyclone in the tropics.

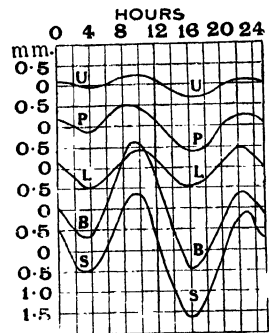

Fig. 29.— Diurnal variation of pressure at different latitudes.

The diurnal variation of pressure cannot yet be said to have been explained completely. According to the latest researches it is due to the superposition of at least two distinct oscillations, one called *semi-diurnal wave* giving two maxima and two minima, and the other *diurnal wave* giving only one maximum and one minimum in twenty-four hours. The two daily maxima of the semi-diurnal wave should be equal and so also the two minima. The amplitude of the semi-diurnal wave varies only slightly during the year; it is maximum at the equinoxes and minimum at the solstices. It depends only on the latitude; it is about 2 mm. at the equator and decreases slowly as we proceed towards the tropics beyond which the decrease is rapid so that the amplitude becomes very small at high latitudes. The semi-diurnal wave is the same for all places on the same parallel of latitude. The diurnal wave, on the contrary, depends on topographical conditions, and may vary considerably between stations situated close to each other.

The diurnal variation of pressure is also affected by altitude. In the free atmosphere, or on the tops of isolated mountains, its character can be quite different from what is observed on the plains or on large plateaux; on the tops of mountains the minimum of the night is generally more marked, the morning maximum is delayed, and often the day minimum and the night maximum become unimportant. All these modifications are easily explained by the effect of heat on the layer of air comprised between the peak and the foot of the mountain.

**80. Annual Variation of Pressure** — This does not present any marked regularity and may be very variable from one region to another. In general, it is least at the equator and increases over the tropical zones; but at higher latitudes there does not seem to be any definite relation between the latitude and the annual variation of pressure. The only law that holds good in the temperate zones is that the pressure is high in winter and low in summer in the interior of the continents, while over the oceans the pressure is high in summer and low in winter. These contrary variations on land and on sea are due to the effect of temperature. In summer the continents are warmer than the surrounding seas, and consequently a part of the air over the continents flows over to the sea with the result that the pressure over the seas becomes higher than over the continents; in winter the conditions are reversed.

The annual variation of pressure at a station is influenced by its altitude. The difference in pressure between two stations on the same parallel of latitude but at different heights is clearly equal to the weight of the column of air (comprised between the two levels) which is smaller the higher its temperature; the difference of pressure must therefore be greater in winter than in summer.

**81. Isobaric Charts.** — In order to study the distribution of pressure over the surface of the globe it is necessary to eliminate the effects of altitude and of the variation of gravity. All the barometric heights observed at stations in all parts of the world have to be reduced to the mean sea-level and to 45° latitude. The pressures thus reduced are then plotted on a map and lines drawn through points having the same

pressure. Such lines are called *isobaric lines* or simply *isobars*. Fig. 30 gives the distribution of the annual normal pressure over the globe. The following characteristics will be noted. In the equatorial region there is a zone over which the pressure is below 760 mm. On either side of this equatorial belt of low pressure, slightly beyond the tropics, there are two belts of high pressure, the maxima of pressure exceeding 766 mm. in some parts. The one at 35°N has its area of maximum pressure over the Pacific Ocean, the Atlantic Ocean and Central Siberia. The southern belt of high pressure at 30° has its maxima over the Pacific Ocean, the South Atlantic Ocean and the Indian Ocean. From

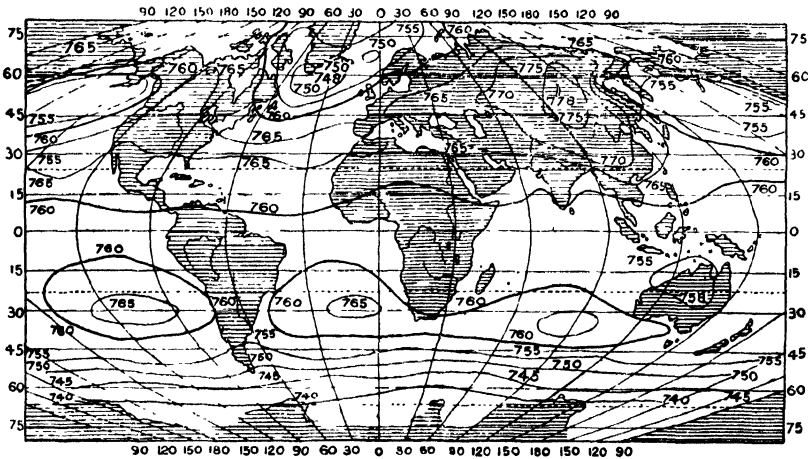

Fig. 30.—Annual Isobars

these two belts of high pressure, the pressure falls off rapidly as we proceed towards the poles; the diminution is quite regular in the southern hemisphere, but in the northern hemisphere the regularity is destroyed due to the presence of continents. It will be noticed that in the southern hemisphere the annual normal pressure is below 750 mm. everywhere beyond latitude 50° or 52°; in the northern hemisphere there are two marked minima near the pole, one in the North Pacific near Alaska and the other between Iceland and Greenland, each with an average pressure below 754 mm. It will also be noticed that the diminution of pressure is much greater in the southern hemisphere than in the northern. As in case of the distribution of temperature, the irregularities in the distribution of pressure over the globe are due to the heterogeneity of the earth's surface.

**82. Monthly Isobaric Charts.**—We shall now consider the monthly distribution of pressure over the globe. It will be sufficient for this purpose to discuss the isobaric charts for the two extreme months of January and July. The distribution of isobars for these months is represented in Figs. 31 and 32.

We see on these charts the equatorial minimum and the two maxima beyond the tropics just as on the annual chart, but their positions are

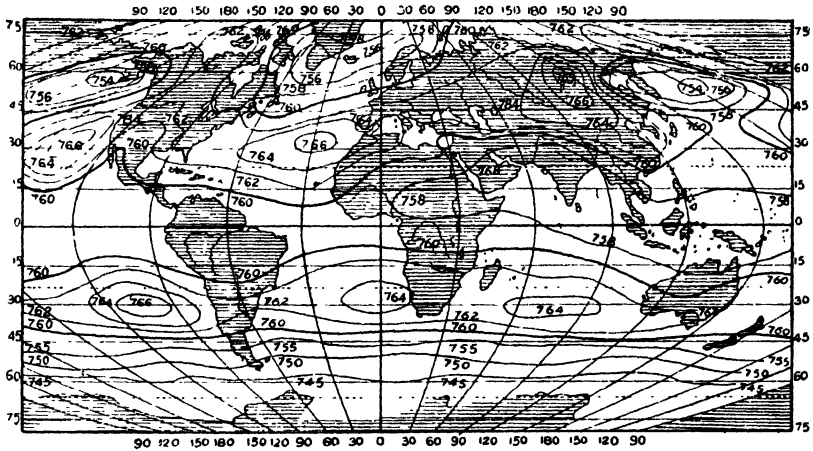

Fig. 31.—Isobars of January

slightly different. The equatorial minimum descends to the south of the equator in January, and goes up to the north of the equator in July;

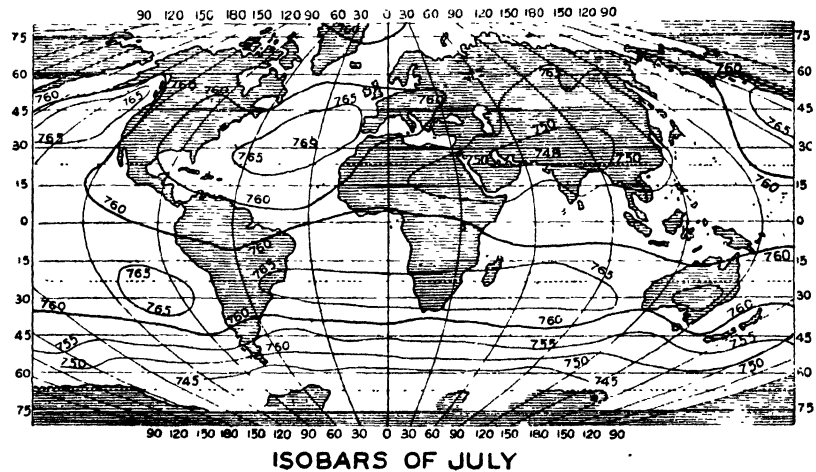

Fig. 32

the same is also true of the two maxima of the sub-tropical regions. There is thus a certain correlation between the migration of the pressure belts, and the migration of the temperature belts, or of the sun.



But a close examination shows that the course of isobars is not determined solely by the course of isotherms. In the extra-tropical latitudes the distribution of pressure is conditioned by other factors besides the distribution of temperature, particularly by the motion of the atmosphere, so that the distribution is not simply thermal but also dynamic.

It may be observed here that there is yet no satisfactory explanation\* of the occurrence of the permanent oceanic anticyclones at the surface level in latitude 35°N and 30°S. And it should be remembered that the high pressure areas over the continents are semi-permanent; therefore, any explanation of the cause of the subtropical high pressure ridge would be real if it were applicable to the permanent oceanic highs. Attempts † have, however, been made to explain theoretically the cause of the high pressure ridge at lat. 35°N and 30°S; but at the present state of our knowledge it would be best to regard the existence of the subtropical highs as an observed fact, which, as we shall see later, can serve as a satisfactory starting point for the theory of the westerly winds of the temperate zones.

Apart from the peculiarities just indicated the monthly isobaric charts reveal other peculiarities. On the January chart the equatorial belt of low pressure shows minima over South America, South Africa and Australia, while the July chart shows one very pronounced minimum over India. This low over India is so pronounced that it appears even in the annual isobaric chart. In January the high pressure belt of the northern hemisphere shows two small areas of very high pressure over North America and Siberia; in July the highs over the continents have disappeared and two peaks of pressure have developed over the Pacific and the Atlantic Oceans. In the North Polar regions a pronounced low appears in the neighbourhood of Iceland on both the January and July charts, and another low near Alaska in January but not in July. The high pressure belt of the southern hemisphere shows three maxima over the South Atlantic, South Pacific and Indian Oceans on both the charts, while a small peak of high pressure appears over South Africa on the July chart.

## VII. WATER VAPOUR IN THE ATMOSPHERE

**83. Distribution of Water Vapour in the Lower Atmosphere.**—We have considered in secs. 27—33 the methods of measuring water vapour in the atmosphere. Water is supplied to the atmosphere by evaporation and is distributed throughout by the processes of diffusion, convection and wind. Diffusion is a very slow process so that the distribution of moisture in the atmosphere is mostly effected by convection and wind.

The geographical distribution of relative humidity has not yet been subjected to a systematic investigation. But on the whole, one can say that the tension of water vapour is maximum in the equatorial regions and diminishes as we proceed to the higher latitudes on either side of the equator. The zone of maximum changes position with the Sun. It is farthest to the north of the equator in July and August, and farthest to the south in January, the amplitude of this movement being 5° to 6°

\* See Barlow, *Q. J. R. Met. Soc.* (1931), Vol. 57, p. 9.

† See Exner, *Encyclop. d. Math. Wissenschaft.*, Vol. VI, I, B (Geophysik). Also H. P. Berlage, *Met. Zeit.*, Heft 11, November 1931.

on either side of the equator. In the zone of maximum the tension of water vapour is generally slightly above 20 mm.; but in some parts for example in India in July, it exceeds over 25 mm. The absolute minima of the tension of water vapour occur in winter over the cold continents of the northern hemisphere. In Siberia and the northernmost parts of America for example, the tension of water vapour goes down below 1 mm. in January. The relative minima occur in the interior of continents, particularly over the deserts; the mean tension of water vapour in the Sahara, for example, is below 5 mm. in January and below 10 mm. in July, while it exceeds 10 mm. and 20 mm. respectively during these two months at the same latitude on the Atlantic coasts and on the whole of South-east Asia.

The pressure of water vapour in the free atmosphere diminishes rapidly with altitude, and this decrease is much more rapid than on the hills. The mean monthly values of vapour pressure in the free atmosphere over Agra are given in the following table quoted from "Memoirs of Indian Meteorological Department, Vol. 25, Part V."

*Table 7.- Mean monthly values of vapour pressure (in millibars) in the free atmosphere over Agra.*

Height in gkm.	Jan.	Feb.	Mar.	Apr.	May	June	July	Aug.	Sept.	Oct.	Nov.	Dec.
Surface (0·17)	10·0	13·9	8·7	10·0	15·9	18·0	33·3	31·4	26·2	16·9	12·2	12·2
0·5	8·7	13·9	11·4	9·3	..	18·0	29·5	..	20·4	15·9	12·2	..
1·0	7·0	10·0	10·0	7·0	9·3	18·0	24·6	24·6	20·4	13·0	9·3	7·0
1·5	5·2	8·1	7·5	6·1	7·5	13·9	23·1	21·8	18·0	11·4	7·0	5·2
2·0	4·0	6·1	7·5	4·7	6·5	12·2	19·2	18·0	13·9	8·7	5·6	5·2
2·5	3·4	4·7	5·6	3·7	5·6	10·7	16·9	16·9	10·7	6·1	4·7	4·0
3·0	3·1	3·1	5·2	3·1	4·4	8·7	14·9	13·0	9·3	4·4	4·4	3·4
4·0	1·7	2·0	2·9	2·0	2·4	6·1	10·7	7·0	6·5	2·9	2·4	2·0
5·0	1·0	1·1	1·8	0·9	1·0	3·7	7·0	5·2	4·0	1·7	1·3	1·0
6·0	0·6	0·6	1·0	0·6	0·6	2·2	5·2	4·0	2·6	0·9	0·6	0·6
7·0	0·3	0·3	0·3	0·3	0·3	1·4	3·1	2·6	1·4	0·5	0·3	0·3
8·0	0·1	..	0·2	0·1	0·1	0·9	1·8	1·7	0·9	0·2	..	..
9·0	..	..	..	..	..	..	1·0	0·8	0·6	..	..	..
10·0	..	..	..	..	..	..	0·5	0·3	0·3	..	..	..

**84. Water Vapour in the Stratosphere.**—The remarkable fact that the boundary between the troposphere and the stratosphere is the highest level at which clouds can form makes it particularly interesting to investigate the distribution of water vapour\* in the tropopause and above it. Unfortunately the hair hygrometer which is up till now the only instrument that can be used for the purpose, becomes extremely insensitive at low temperatures.

Gold† suggested that the upper limit of the troposphere may also be the upper limit of the water vapour atmosphere. Thus the air arriving at the base of the stratosphere will be completely saturated, though the actual amount of water vapour will be small compared with that near the earth's surface. Simpson‡ on this basis calculated the amount of water vapour and found that there should be at least 0·3 mm. of precipitable water in the stratosphere. On the assumption that water vapour in the stratosphere is in diffusive equilibrium, with other gases Wegener calculated the distribution of water vapour in the stratosphere.

It was, however, noticed from the calculations that the relative humidity in the stratosphere ought to diminish with altitude and that from 30 km. upwards, it should be exceedingly small. This explains, at least qualitatively, why clouds do not form in the stratosphere. However, the phenomenon of luminous night clouds, which form at a height of 70–80 km. casts some doubt on the strict validity of the above theoretical considerations.

**85. Diurnal and Annual Variation of Humidity.**—The humidity of the atmosphere shows a diurnal variation. At the inland low-level stations of the middle latitudes the absolute humidity curve for a winter day shows one maximum and one minimum, following very closely the temperature curve, the minimum occurring about sunrise and the maximum between 14 h. and 15 h. in the afternoon. In summer for an inland station the curve shows two maxima and two minima, the minima occurring at about sunrise and between 16 h. and 17 h. while the maxima between 8 h. and 9 h. and between 20 h. and 21 h. For stations near the sea and for hill stations there is no double oscillation, the diurnal variation being similar in all seasons to that at inland low-level stations in winter. This diurnal variation is due to the continuous rise in temperature of the air from morning to the afternoon which increases the rate of evaporation. The minima at 16 h. in summer at inland stations is due to the rapid vertical convection in the middle of the day which carries away much of the moisture to upper regions. In India at Calcutta for example, the diurnal variation of absolute humidity during the southwest monsoon period is similar to that in winter at the inland low-level stations of the middle latitudes, while in other seasons it resembles that at the latter in summer. The relative humidity curve shows a diurnal variation approximately inverse to the temperature curve, the

\* See Kleinschmidt, *Beitr. z. Phys. D. freien Atm.*, Vol. 2, p. 99 (1907); Vol. 2, p. 205 (1908); also A. Wegener, *ibid.* Vol. 4, 1, p. 55 (1910).

† *M. O. Geoph. Memoir*, No. 5, London

‡ *Memoir Roy. Met. Soc.*, Vol. 3, No. 21,

maxima occurring at about sunrise and the minima between 14 h. and 15 h. This is because the temperature and consequently the capacity of the air to hold water vapour increases much faster than the absolute humidity and thus the air becomes relatively drier in the afternoon. In the middle latitudes the annual variation of absolute humidity shows a maximum in summer and a minimum in winter, while the relative humidity shows a minimum in April and a maximum in December. In a tropical country like India both the absolute humidity and relative humidity show a minimum in winter and a maximum in summer. This is due to rains falling in summer.

**86. Methods of Causing Condensation.**—The water vapour present in the atmosphere condenses into liquid water or solid ice if the actual vapour pressure exceeds the maximum vapour pressure corresponding to the existing temperature. This happens almost exclusively when the air is cooled down more or less suddenly; but in rare cases it may occur if the vapour pressure happens to increase due to some local effects. For example, if air saturated with water vapour is compressed, some of the vapour must condense, but such a phenomenon hardly occurs in the atmosphere.

The cooling of air may take place by the following three processes :

- (1) Due to radiation of heat or due to contact with cold bodies.
- (2) Due to the mixing of cold and warm air masses.
- (3) Due to adiabatic expansion caused by sudden decrease of pressure.

The first process should have been the most effective in producing precipitation had it been active in large masses of air. But air, even when it is moist, is a poor conductor and radiator of heat, so that radiation and conduction of heat play a minor role in the formation of precipitation. The result of the loss of heat by radiation or by contact with cold bodies, such as the surface of the earth in winter, cold walls, stones, etc., is the formation of mist, fog, dew, etc.

The second mode of condensation depends essentially on the experimental fact that the saturated vapour pressure of water increases much more rapidly with increase of temperature

than the temperature itself. Thus if two equal masses of air, initially saturated at temperatures  $t$  and  $t'$  respectively, are allowed to mix together, they will acquire the mean temperature  $t_m = \frac{t+t'}{2}$  while the mean vapour pressure will be  $\frac{e+e'}{2}$  but on account of the above property this mean vapour pressure will be greater than  $E$ , the maximum vapour pressure at  $t_m$  and therefore the excess of water vapour will condense.

If the two masses of air are not saturated before mixing, there may be condensation in some cases. This will depend on the proportions of the mixture. If both the masses are very near the point of saturation, then condensation may take place at some places, and no condensation or even evaporation at others. This explains the formation and the rapid disappearance of certain kinds of clouds.

The admixture of two samples of air at different temperatures is the least effective of the three processes of condensation mentioned above. A simple calculation shows that to produce a quantity of rain, which will form a layer of 1 mm. thickness, it is necessary to mix completely two equal masses of saturated air of 6850 metres thickness at temperatures  $0^\circ\text{C}$ . and  $20^\circ\text{C}$ . respectively. These conditions are never realised in nature. The admixture of different samples of air cannot therefore produce any appreciable rain, but it plays an important part in the formation of certain kinds of fogs and clouds.

The third process is the most important because it is active on a large scale and produces cloud and rain. When moist air is allowed to expand adiabatically its temperature falls and some of its moisture is condensed if the temperature falls below the dew point. This is the process which generally takes place in the atmosphere. An ascending current of moist air suffers a decrease of pressure as it ascends; it therefore expands almost adiabatically and parts with some of its moisture. To calculate the cooling produced we have to apply the first law of thermodynamics. This is done in detail in the next few sections, after which the forms of condensation are considered.

## VIII. THE THERMODYNAMICS OF THE ATMOSPHERE

**87. Equilibrium of the Atmosphere.**—In sec. 77 we already applied the laws of thermodynamics to calculate the fall in temperature of a rising mass of air. It was shown that the temperature of the atmosphere should theoretically decrease with the increase of height at the rate of about  $1^{\circ}\text{C.}$  per 100 metres elevation. This is known as the adiabatic rate. If the actual gradient of temperature agreed with the adiabatic rate, any portion of air, transferred from one level to another adiabatically would have at every stage the same temperature and density as the adjacent air and therefore if left to itself will neither rise nor fall. But if the actual temperature gradient be different vertical motion of air would set in. The conditions of stability of the atmosphere in the vertical direction can be represented graphically in the following way :—

1. Let us assume that the vertical gradient of temperature has been measured by means of kite or balloon ascents and that it has been found to agree with the theoretical adiabatic rate of  $1^{\circ}\text{C.}$  decrease per 100 metres elevation. Then the curve representing the relation between height and temperature will be a straight line; let it be represented by the line AB in Fig. 33. Now let a particle of air rise adiabatically from the surface of the earth. Its motion will be represented by the line AB and thus wherever it goes it has the temperature of the surrounding air, that is to say, it is not only in thermal but also in mechanical equilibrium. Such equilibrium is said to be *indifferent*.

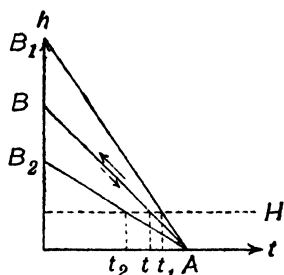

Fig. 33.—Illustration of indifferent, stable and labile equilibrium

2. Let us now assume that the experimentally determined vertical gradient of temperature is less than the theoretical (AB, in Fig. 33). Then the air particle from the ground when it reaches the height H has the temperature

$t$  which is lower than  $t_1$ , the temperature of the air at that height. It is therefore heavier than the surrounding air and must sink and return to its original level. Inversely, a particle of air descending from an upper layer will be warmer than the air at height  $H$  and must therefore rise back to the height from which it came down. Thus the atmosphere is in *stable equilibrium*.

3. Finally let the vertical gradient of temperature be greater than the theoretical adiabatic rate ( $AB_2$  in Fig. 33). If the mass of air rises from the surface of the earth to the height  $H$  its temperature  $t$  will be higher than the temperature  $t_2$  of the surrounding air. It will therefore be lighter than the air at any height where it arrives and must, therefore, rise indefinitely. Inversely a mass of air descending from a high level will be heavier than the air at any lower level which it reaches and must therefore descend continuously till it is stopped by the surface of the earth. In this case therefore the atmosphere is said to be in *labile equilibrium*, so that the slightest disturbance would produce a complete upheaval.

**88. Potential Temperatures.**—If we intend to compare the thermal states of different masses of air at different temperatures and pressures, we have to bring them adiabatically to the same pressure and then compare the resulting temperatures. The usual convention is to calculate the temperatures corresponding to the normal pressure (760 mm. of mercury); these temperatures are known as *potential temperatures*. The notion of potential temperature was introduced in meteorology in 1888 by Köppen\* and Bezold.† It is evident that like the entropy the potential temperature must be the same at all heights in the case of convective equilibrium. If it increases with the height, the layers must be in stable equilibrium; if it decreases with the altitude the equilibrium must be labile.

\* *Deutsch. Met. Gesell.* Hamburg, 30 Juni, 1888.

† *Berl. Sitz-Ber.*, 15 Nov., 1888.

**89. Maximum Limiting Value of Temperature Gradient or Auto-Convection Gradient.**—Even when the actual decrease of temperature with altitude is greater than the adiabatic rate, there may be equilibrium in the atmosphere, although a slight disturbance is enough to bring about a complete upheaval. It is therefore interesting to investigate if there is a limiting value of the vertical temperature gradient beyond which no equilibrium is possible.

According to the gas laws the density varies directly as the pressure and inversely as the temperature. Now as we go up in the atmosphere the pressure and temperature both decrease. Hence due to decrease of pressure alone the density would decrease with altitude while due to the decrease of temperature the density would increase. With a suitable temperature gradient it may so happen that these two effects balance, i.e.,  $\frac{d\rho}{dz} = 0$ . Then the density of air will be the same at all heights. If the actual temperature gradient be greater than this, the upper layers will be denser than the lower ones and will come down by gravity and there will be no equilibrium. Thus in such cases auto-convection sets in, and a gradient greater than the auto-convection gradient is not possible.

We can easily calculate this temperature gradient necessary for just starting auto-convection. In this case

$$\frac{d\rho}{dz} = 0 \quad \dots \quad \dots \quad \dots \quad (15)$$

The equation of state for an ideal gas can be written

$$\rho = \frac{pM}{RT} \quad \dots \quad \dots \quad \dots \quad (16)$$

where  $\frac{R}{M}$  is the gas constant for 1 gram of air.

Differentiating we get

$$\begin{aligned} d\rho &= \frac{M}{R} \left( \frac{dp}{T} - \frac{p dT}{T^2} \right) \\ &= \frac{pM}{RT} \left( \frac{dp}{p} - \frac{dT}{T} \right) \quad \dots \quad \dots \quad (17) \end{aligned}$$

Now the variation of  $p$  in the atmosphere is given by

$$dp = -g\rho dz = -\frac{g\rho M}{RT} dz$$

Substituting this value of  $dp$  in (17) we have

$$\begin{aligned} d\rho &= -\frac{pM}{RT} \left( \frac{gM}{RT} dz + \frac{dT}{T} \right) \\ \text{or} \quad \frac{d\rho}{dz} &= -\frac{pM}{RT^2} \left( \frac{gM}{R} + \frac{dT}{dz} \right) \quad \dots \quad \dots \quad (18) \end{aligned}$$

Hence for (15) to be true we must have

$$\begin{aligned} \frac{dT}{dz} &= -\frac{gM}{R} = -\frac{981 \times 28.8}{8.3 \times 10^7} \text{ degree/cm.} \\ &= -0.034 \text{ degree per metre} \quad \dots \quad \dots \quad (19) \end{aligned}$$



Thus a vertical temperature gradient of 3.4 C. per 100 metres is impossible in the atmosphere at rest; *i.e.*, the upper limit of labile equilibrium is a decrease of temperature of 3.4°C. per 100 metres elevation.

The conditions of equilibrium of the atmosphere can be summarised as follows :—

$$\begin{aligned} \frac{dT}{100 m} > 3.4 & \quad \text{No equilibrium.} \\ 3.4 > \frac{dT}{100 m} > 1.0 & \quad \text{Labile equilibrium.} \\ \frac{dT}{100 m} = 1.0 & \quad \text{Indifferent or Convective equilibrium.} \\ \frac{dT}{100 m} < 1.0 & \quad \text{Stable equilibrium.} \end{aligned}$$

**90. Adiabatic Change of Humid Air.**—In what precedes we considered the adiabatic changes of dry air. In reality, however, the atmospheric air is moist. The adiabatic rate for moist air is slightly less than that for dry air since the specific heat of water vapour at constant pressure is greater than that for dry air. But the difference is very small because of the smallness of the quantity of water vapour in the atmosphere. Thus when moist air is lifted by about 100 metres its temperature will fall by 1°C. When sufficient height is reached the air becomes saturated and condensation starts, thereby liberating heat

In the case of condensation of water vapour directly into ice an amount of heat equal to the heat of sublimation is liberated which is equal to 680 cal. for each gram.

The liberation of heat due to condensation must oppose the lowering of temperature due to expansion. Since in air saturated at a higher temperature more vapour is condensed due to a given cooling than in air saturated at a lower temperature, it follows that for a given expansion the cooling will be less at higher temperatures than at lower temperatures. Table 8 quoted from Haun's *Lehrbuch der*

Table 8. — *Precipitation at different temperatures per degree fall of temperature.*

Temp. (°C)	-15	-10	-5	0	5	10	15	20	25	30
Precipitation (in grams)...	0.12	0.17	0.25	0.33	0.43	0.57	0.75	0.98	1.25	1.59

*Meteorologie* gives the amount of precipitation due to a cooling of 1°C. from a cubic metre of saturated air at different temperatures.

We see from the table that if saturated air at 15°C. is cooled by 1°C. the amount of precipitation will be three times the amount precipitated if the air were at -5°C. so that the heat of condensation liberated at 15°C. will also be three times that at -5°C. It follows therefore that a considerably larger amount of heat must be withdrawn from air, saturated at 15°C. in order to cool it by 1°C. than from air at -5°C. Inversely, withdrawal of the same amount of heat will produce more cooling in the colder air than in the warmer. These relations are very important in meteorological phenomena. We shall therefore discuss them from a theoretical point of view.

Hann\* was the first to calculate the difference between the adiabatic temperature decrease of dry air and of humid air. Hann's formulæ were recalculated by Guldberg and Mohn† in 1878, and in 1884 Hertz ‡ gave adiabatic diagrams which represent the whole process graphically. The tables calculated by him were again calculated and slightly modified by Neuhoff|| in 1900.

From the first law of thermodynamics if  $dQ$  be the amount of heat supplied to a given mass of air

$$\begin{aligned} dQ &= c_p dT - \frac{v}{J} dp \\ &= c_p dT - \frac{RT}{M_p J} dp \end{aligned}$$

In the case of a mass of saturated air rising upwards, the heat  $dQ$  is added as a result of an amount  $-dm$  of vapour being condensed. Hence

$$dQ = -L dm$$

where  $L$  is the latent heat of vaporization. Therefore

$$-L dm = c_p dT - \frac{RT}{M_p J} dp \quad \dots \quad \dots \quad (20)$$

The total mass  $m$  of water vapour in the air per c. c. is given by

$$m = 0.623 \frac{e}{p} \times$$

where 0.623 is the ratio of the molecular weight of water vapour to the

\* *Zeits. d. Ost. Ges. f. Met.* (1874), p. 321.

† *Zeits. d. Ost. Ges. f. Met.* (1878), p. 113.

‡ *Met. Zeits.* (1884), p. 421.

|| *Abhand. d. Preuss. Met. Inst.*, No. 6, Berlin (1900).

weighted mean of the molecular weight of the constituents of dry air,  $e$  the vapour pressure,  $p$  the pressure of the air and  $\rho$  the density of the air. Hence

$$\frac{dm}{m} = \frac{de}{e} - \frac{dp}{p}$$

Substituting this value of  $dm$  in (20) we have

$$-Lm \frac{de}{e} + \frac{Lm}{p} dp - c_p dT + \frac{RT}{p} dp = 0$$

$$\text{or} \quad \left( c_p + Lm \frac{de}{e} \cdot \frac{1}{dT} \right) dT = \frac{dp}{p} \left( Lm + \frac{RT}{J} \right) \quad \dots (21)$$

Now  $dp = -g\rho dz = -\frac{gMp}{RT} dz$ . Substituting this value in (21) we get

$$\frac{dT}{dz} = -\frac{g \left( \frac{LmM}{RT} + \frac{1}{J} \right)}{c_p + Lm \frac{de}{e} \cdot \frac{1}{dT}} \quad \dots \quad (22)$$

This is the rate of decrease of temperature with elevation of saturated air. All the quantities on the right-hand side of this equation are known, so that  $\frac{dT}{dz}$  can be evaluated and tables for ready reference can be prepared. Table 9 gives the decrease of temperature per 100 metres rise of saturated air rising from the surface of the earth. It is based on the assumption that the amount of moisture carried by a given quantity of air remains constant during its ascent. Fig. 34 gives Hertz's graphical representation of the process.

*Table 9.*—Temperature decrease per 100 metres rise of saturated air (after Neuhoff)

Height in metres.	Initial temperature in °C (on the surface of the earth).						
	30° C.	20	10	0	-10	-20	-30
0	0.37	0.44	0.54	0.62	0.75	0.86	0.91
1000	0.37	0.46	0.56	0.68	0.82	0.90	
2000	0.38	0.49	0.56	0.75	0.87	0.95	
3000	0.40	0.51	0.65	0.82	0.89		
4000	0.42	0.57	0.73	0.88			
5000	0.43	0.59	0.80				
6000	0.45	0.63	0.84				
7000	0.48	0.72					

The coordinates of the curves in Fig. 34 are temperature and height. The height scale can be easily converted into the pressure scale with the help of the pressure curves (slanting lines). There are two principal systems of curves, *viz.*, the dry adiabatics, (continuous lines) inclined at 45° and the steeper condensation adiabatics (broken, slightly curved lines). A third system of curves gives the quantity of moisture required for

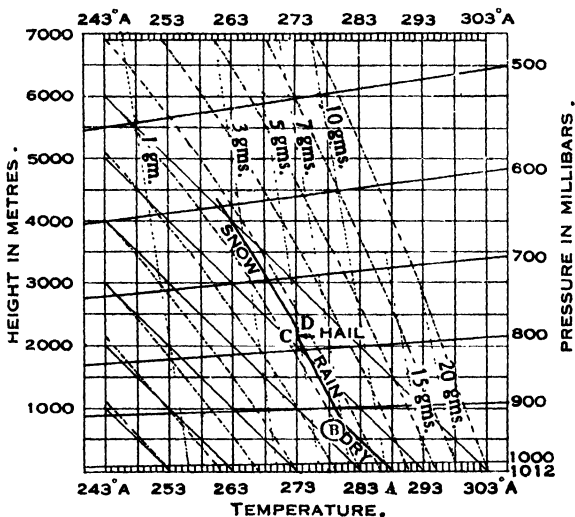

Fig. 34.—Adiabatic diagram (Hertz)

saturation so that the points of transition from the dry adiabatic to the condensation adiabatic can be determined.

**91. Height at which Condensation takes place.**—In the preceding theoretical discussions we assumed that the air rising from the surface of the earth was already saturated with water vapour. In reality, however, the amount of energy available is rarely saturated at the earth's surface. It must rise to a certain height and become cooled before it is completely saturated, so that during the first stage of elevation it follows the dry adiabatic curve and then the second stage is reached when a condensation adiabatic curve is traced. Such a path is represented by the thick line ABCD... in the figure. The curve has a sharp bend which corresponds to the height at which condensation begins and, therefore, to the base of clouds. These heights can be determined with the help of Hertz's diagram, if we know the relative

humidity of the air under consideration. Thus if we take air at 1012 mb. and temperature  $288^{\circ}\text{A}$  and relative humidity 70 % (represented by A) a line AB is drawn parallel to the dry adiabatics cutting the line for 7.1 grams at B. B gives the height where condensation begins.

The height of condensation can also be calculated by suitable formulæ given by Ferrel\* and Henning. † Table 10 gives the relation between the condensation height, temperature and relative humidity.

*Table 10.—Condensation height in relation to temperature and relative humidity at the earth's surface.*

Temperature °C.	Condensation height for relative humidity of				
	50 %	60 %	70 %	80%	90 %
— 20	989 m	736 m	514 m	329 m	157 m
— 10	1089	812	572	360	172
0	1189	885	624	394	187
+ 10	1290	961	678	430	204
+ 20	1393	1038	732	461	220
+ 30	1498	1117	788	498	237

**92. Different Stages of Adiabatic Expansion.**—In the ascensional motion of humid air there are four principal stages. The thermodynamic equations of these stages were first derived by Hertz (*loc. cit.*) and have been briefly considered before. Here we shall consider the results of Hertz's theory in some detail.

1. *Dry Stage.*—This represents the adiabatic expansion of air before the point of saturation and has been already discussed.

2. *Cloud or Rain Stage.*—Cloud formation begins at the height of condensation (B in Fig. 34) and continues up to that height at which the temperature falls to  $0^{\circ}\text{C}$ . This is represented by BC in the figure and is called the rain stage. BC is parallel to the condensation adiabatic and meets the  $273^{\circ}$  coordinate at C. The 5-gram line passes through C and therefore about 2.1 gms have been formed as rain. The height of C can also

\* Ferrel, *A Popular Treatise on the Winds*, New York, 1889.

† Henning, *Met. Zeits.*, Vol. 30, p. 125 (1895).

be calculated from Table 10, and will be equal to about  $\frac{10 \times 100}{0.51} = 1960$  metres above B.

3. *Hail Stage.*—At  $0^{\circ}\text{C}$ . the air contains water vapour as well as liquid water drops. If there is further expansion, the water can freeze and so long as freezing goes on there is no lowering of temperature. For a certain time therefore the air must remain at  $0^{\circ}\text{C}$ . in spite of its continuous ascension, the length of this period depending upon the amount of water present. This is represented by CD and is known as the *hail stage*.

4. *Snow Stage.*—Below  $0^{\circ}\text{C}$ . water vapour can freeze directly into ice. So, after the hail stage, if there is further expansion the water vapour contained in air will pass directly into the solid state. The process is similar to that of the rain stage, the only difference being that in place of the heat of condensation the heat of sublimation comes into play. This is represented by DE which is parallel to the condensation adiabetic.

There is one fault of the diagram. It assumes that all the moisture is carried by the ascending air through all the stages whereas the rain, hail and snow generally separate out from the air.

There is another method, which is in general use like the Neuhoff diagram, of representing the thermodynamical state of the atmosphere. This has been developed by Sir Napier Shaw\* and called the *tephigram* (T- $\phi$  diagram) method, because the coordinates of the diagram are temperature (T) and entropy ( $\phi$ ). The tephigram is very convenient for determining the actual amount of energy available for convection or other effects, but the actual plotting of the tephigram is less simple than that of the Neuhoff diagram. There are many other uses of the tephigram, which (as also the Neuhoff diagram) gives a large amount of information in an extremely convenient and compact form, but because of limitation of space we cannot go into all the details here.

In this connection we may also mention the term introduced into meteorology by Bezold and Knoche† (1905-1906), namely, *equivalent temperature*. The equivalent temperature of a mass of moist air is the sum ( $T + \Delta t$ ) of its actual absolute temperature (T) and the increase ( $\Delta t$ ),

\* See Sir N. Shaw, *Manual of Meteorology*; C. M. Alvord and R. H. Smith, No. 1, *Prof. Notes*, Mass. Institute of Technology, Meteorology Course.

† Bezold, *Ges. Abh.*, X and XI, Braunschweig, 1906. Knoche, *Arch. d. Deutsch. Seewarte*, 1905, No. 2.

which would be produced by the heat liberated due to the adiabatic change of state of the moisture contained in the air and would therefore be different according as the change takes place from vapour to water or from vapour to ice. The equivalent temperature of a mass of moist air is thus a measure of its heat-content.

We have seen that if a mass of dry air is lifted or lowered adiabatically, its potential temperature remains constant. In the case of moist air it is the *equivalent potential temperature* that remains constant during adiabatic expansion or compression. The idea of the equivalent potential temperature seems to have been introduced first by W. Schmidt.\* It is defined as that equivalent temperature which the moist air mass has at a given pressure. Thus, while the potential temperature permits of a comparison of the heat-contents of samples of dry air at different levels, the equivalent potential temperature makes possible a comparison of the heat-contents of samples of moist air at different levels. The equivalent temperature is thus useful in the diagnosis of air samples. With the help of tables specially prepared for the purpose it is possible to determine the values of the equivalent temperatures directly from readings of the wet-bulb thermometers.

**93. Forms of Condensation.**—The most important forms of condensation of the water vapour in the atmosphere are clouds, rain, hail, snow, fog and dew. It has been definitely proved that the most effective cause of all forms of condensation except dew and fog, is the upward motion of moist air.

When objects on the surface of the earth (or the surface of the earth itself) get cooled in the night below the "dew-point," the water vapour in the atmosphere deposits itself as *dew*, preferably on surfaces which are good radiators and bad conductors of heat. A clear sky and absence of wind are necessary for the formation of dew. This facilitates nocturnal radiation and prevents mixing of air. An inversion of temperature near the ground almost always precedes the formation of dew.

Sometimes the temperature of air falls below 0°C. before the dew point is reached. In this case when condensation takes place, the water vapour is directly converted into crystals of ice. A deposit of these crystals is called *frost* or hoar frost. Frost is injurious to vegetation especially when it is formed

\* Schmidt, *Met. Zeit.*, 1921, pp. 262-268. Linke, *Met. Zeit.*, 1922, p. 267; Robitzsch, *Met. Zeit.*, 1928, p. 318; see also Normand, *Ind. Met. Mem.*, Vol. 23, Part 1.

at a very low temperature. Tender vegetation can be easily protected from frost by covering it with cloth or paper or some other thing. The use of a smoke layer for the purpose is also being investigated.

*Fogs* are caused by smoke or by condensation of water vapour in the lowest regions of the atmosphere or by a combination of both. Ordinary land fogs are formed when a warm mass of air comes in contact with the cold surface of the earth during the evening, night or morning and becomes cooled. Due to turbulence caused by friction this cold air mixes with the layers above it. The vapour present in the air thus condenses and a fog gradually extends upwards. This condensation takes place on the dust, smoke and other hygroscopic particles in the air which serve as condensation nuclei. Radiation fogs (or fogs formed by the cooling of the ground and of the moist air above it due to radiation) are also common over land areas but are generally shallow. The ground becomes cooled by radiation in the night and the air above it also becomes sometimes cooled below the point of saturation. Some of the moisture therefore condenses as dew while some remains suspended in the air as fog. Fogs are also common in autumn and winter over seas and rivers. These are produced by cold air coming into contact with the relatively warm air above the water surface. Fogs are almost always accompanied with inversions which extend to some height above the fog. Thus convection currents in the air become impossible and the fog may persist for days under favourable conditions. Owing to its great importance in aviation the causes of the formation of fog have been investigated by several workers\* whose works may be consulted for details.

As we have already said, clouds are formed by the upward motion of moist air. This upward movement is not always a direct vertical motion. In many cases for example when stratified clouds are formed, the motion is a gradual gliding up.

\* A good summary will be found in Georgii's *Flugmeteorologie*, Leipzig (1927).



According as they are formed by a powerful vertical updraft or a slow gliding motion, clouds may have different forms and structure. The study of the general morphology of clouds is of great importance, both theoretical and practical, but cannot be entered into here in detail due to limitations of space. For this special treatises\* may be consulted.

**94. Cloud Classifications.**—The International Meteorological Committee have adopted the following classification of clouds.

Table 11.—*Classification of Clouds*

International nomenclature	Symbol	Average Height
Cirrus ...	Ci	9900 metres
Cirro-Stratus ...	Ci—St	8300
Cirro-Cumulus	Ci—Cu	6500 "
Alto†-Stratus	A—St	4300 "
Alto-Cumulus	A—Cu	4300 "
Cumulus ...	Cu	Peak 1500—2000 m.
Cumulo-Nimbus	Cu—Nb	Peak 3000—5000 m.
Strato-Cumulus	St—Cu	2000
Nimbus ...	Nb	900—1200
Stratus ...	St	500

This classification is based on that of Luke Howard (1803) and on some modifications introduced by Abercromby and Hildebrandsson. The ten classes given in Table 11 can be divided into five principal groups in consideration of their heights and modes of formation, namely, *high clouds*, *intermediate clouds*, *low clouds*, *clouds of ascending currents and lifted fogs*. The ordinary fog, which forms along rivers and creeks and even in mountain valleys during any still, cloudless night

\* For example, Clayden, *Cloud Studies*; Clarke, *Clouds*; Ley, *Cloudland*; A. Wegener, *Thermodynamik der Atmosphäre*, (1924) section V. The Office National Meteorologique, Paris, has published a very useful "Atlas of Clouds." See also S. Mal, *Forms of Stratified Clouds*, *Beitr. Z. Phys. d. freien Atmosp.*, Vol. XVII, p. 40 (1930).

† 'Alto' means 'high.'

of autumn in cold countries and of winter in hot countries like India, after a calm, warm day is slightly different from what are usually called clouds. The difference consists only in the location of the fog. The cause of the formation of this type of fog is the free radiation of the ground and the lower air; it is generally known as radiation fog or land fog as it extends from the ground upwards.

### HIGH CLOUDS

1. *Cirrus*.—These are uniformly white clouds in the form of filaments or fibres and sometimes in bands. Sometimes the fibres combine together and look like feathers.

2. *Cirro-Stratus*.—These are whitish veil-like clouds which give a milky look to the sky. Often they are completely diffuse, but may sometimes present a more or less definite fibrous structure which resembles that of cirrus.

Both cirrus and cirro-stratus clouds are composed of crystals of ice which are responsible for the optical phenomena of the atmosphere known as halos (clouds composed of drops of liquid water can produce coloured coronas but no halos). The thermal and mechanical convections, the first prevailing in tropical regions, and presumably both in extratropical, appear to be the causes of the origin of these clouds.

3. *Cirro-Cumulus*.—These are small fleecy white clouds which usually occur in large numbers, producing an effect sometimes described as “curdled sky”; frequently also in rows and groups resembling the patterns on the backs of mackerels, whence the expression “mackerel sky.” Their origin is due to local vertical convections\* induced by local instabilities in the upper air or by the lift or drop of a thin cloud sheet.

### INTERMEDIATE CLOUDS

4. *Alto-Cumulus*.—These are detached, fleecy clouds with shaded portions, often occurring in closely packed groups and rows giving them the appearance of enlarged cirro-cumuli. They

\*See Brunt, *Met. Mag.*, Vol. 60, p. 1 (1925).

give the sky a dappled or piebald look. They are formed in practically the same way as cirro-cumuli.

5. *Alto-Stratus*.—The alto-stratus is a thick greyish or bluish cloud veil, sometimes compact but rarely fibrous, sometimes thin like the cirro-stratus, from which it is often difficult to distinguish. Like the cirro-stratus, the alto-stratus clouds often precede depressions and bad weather. They may result from the flow of warmer over colder air, from the forward running of air forced up in the storm area of a cyclone or even from radiation cooling.

#### LOW CLOUDS

6. *Strato-Cumulus*.—These are large balls or rolls of dark clouds often covering the entire sky. Sometimes they are quite thin and the blue sky can be seen through them at places. They are often very difficult to distinguish from the alto-cumulus clouds. They are formed by vertical convection as is indicated by their rounded tops. A layer of small temperature gradient or even inversion usually overlies the strato-cumuli.

7. *Nimbus*.—They are formless masses of dark grey or black clouds which produce prolonged rain or snow. Their bases often get broken up into patches which float much lower than the main body of the nimbus; these patches are known as *Fracto\*-nimbus* also as "Scuds." Nimbus clouds are chiefly produced by forced convection.

#### CLOUDS OF ASCENDING CURRENTS

8. *Cumulus*.—Thick rounded clouds with dome-like protuberances on their tops and often with horizontal bases. They resemble in appearance the smoke blown out from the funnel of a ship or a locomotive. Sometimes they lose their rounded shape and appear as fragments which continually change form; they are then given the special name of *fracto-cumulus*. Cumulus clouds do not produce rain. They are formed by thermal convection and are therefore very frequent in tropical regions

\* 'Fracto,' meaning 'broken.'

9. *Cumulo-Nimbus*.—These clouds have the appearance of mountains or huge towers. They are often accompanied by a veil of cirro-stratus. The base of cumulo-nimbus clouds is often composed of grey clouds resembling the nimbus. They are rain-clouds like the nimbus and a necessary accompaniment of every thunderstorm. They are caused by strong thermal convection.

#### LIFTED FOG

10. *Stratus*.—The stratus is a low, uniformly grey cloud of wide extent often merging into a nimbus. It results from the under-running of cold air, from the mixing of masses of humid air of different temperatures or even from radiation from levels a few hundred feet above the ground.

**95. Height and Thickness of Clouds.**—The heights of clouds given in Table 11 give only a general indication. In reality the heights of clouds vary within wide limits. The heights of clouds show a marked annual variation. The same kind of cloud is on the average higher in summer than in winter which appears natural considering the fact that the air is hotter and drier in summer so that the level of condensation is higher. For the same reason a given kind of cloud, particularly among the high clouds, forms at a higher altitude near the equator than in the higher latitudes.

The height of a cloud is a function of the temperature and the humidity so that the diurnal variation of these elements produces also a diurnal variation in the height of clouds. It increases from morning till evening and decreases during the night. The effect of the diurnal variation of temperature and humidity is also noticeable in the frequency of cloud kinds. All kinds of clouds are not equally frequent at all times of the day; low clouds are prevalent in the morning and high clouds during the day.

The thickness of clouds is extremely variable; the thickness of cirrus and cirro-stratus clouds is always very small and in many cases does not exceed a few centimetres, while the thickness of cumuli, particularly of the cumulo-nimbus, may be many thousand metres. In certain kinds of cumulo-nimbus Cl. Ley has measured thicknesses of 5000, 7600 and 9700 metres. W. Peppler\* has given the following estimates of the thickness of clouds as obtained from aerological ascents made at Lindenberg and Friedrichshafen:—

Kind	Fog	Stratus	Cumulus	Nimbus	St.-Cu	A-Cu
Thickness in metres.	320	303	500	907	292	132

Inversions or reversed lapse-rate are closely associated with cloud formation. They are found almost invariably above fogs and clouds of

\* *Mete. Zeits.*, 1921 and 1924.

stratus or strato-cumulus type, but are absent above cumulus clouds. Inversions separate layers of air differing in water vapour content and therefore in density. Now just as waves are formed on the surface of separation between water and air, so must also waves be formed on the boundary between layers of air of different densities. Helmholtz\* was the first to point out this possibility and to apply it to explain the formation of wave-like clouds.

**96. Precipitation.**—Four of the seven forms of condensation have already been considered, *viz.*, dew, fog, frost and clouds. The remaining three, rain, snow and hail are included under the general term “precipitation” and require for their production a vigorous condensation.

The cloud consists of minute droplets of water, which on the average, are 0.02 mm. in diameter. These particles, if the convective effect of wind motion be disregarded, would fall under their weight but in so falling they are retarded by viscous forces which are equal to  $6\pi\eta av\ddagger$  for spherical particles  $a$  being the radius of the sphere,  $v$  the velocity of fall and  $\eta$  the coefficient of viscosity. Thus they will first move with an acceleration downwards and then with a steady terminal velocity  $v$  given by

$$6\pi\eta av = \frac{4}{3}\pi a^3 g(\sigma - \rho), \text{ or } v = \frac{2}{9} \cdot \frac{ga^2}{\eta}(\sigma - \rho)$$

This terminal velocity for an average cloud particle is only a few centimetres per second. Generally, however, due to presence of ascending currents, the cloud particles are either kept suspended or are carried upwards. Now as the cloud particles vary widely in size, they are carried upwards by these ascending currents with different velocities, and hence many collisions occur. Whenever two cloud particles collide, they coalesce to form a tiny rain-drop which being heavier begins to fall down since the force due to gravity increases faster than the force due to viscosity. During its fall the raindrop comes into contact with layers of air warmer than itself and some of the water vapour in the air thereby condenses on the cold drop.

\* *Erste Mitt. Sitzsb. d. kgl. Preuss. Akad. d. Wiss. Berlin* (1888) I, p. 646; *Zweite Mitt.*, (1889) II, p. 761.

‡ This was proved by Stokes. See Stokes' *Mathematical Papers*,

Thus the raindrop gradually increases in size and falls with increasing velocity as it travels through the cloud. On emerging from the base of the cloud the raindrop has to traverse through air which is unsaturated and consequently begins to evaporate and becomes smaller and smaller in size as it approaches the earth. Thus it is easy to see why every cloud does not produce rain. This is because cloud particles are kept suspended by ascending currents, and the few raindrops that may be formed (or the cloud particles themselves) evaporate away quickly on crossing the base of the cloud and do not reach the earth. It is only when the condensation is very vigorous that rain is produced. The processes by which rain is generally produced are vertical convection, or forced ascent of moist air by a mountain or due to convergence of winds in a storm at the "fronts."

A raindrop varies in size from very small drops to drops of about 5 mm. in diameter. In this connection we may mention the curious fact established particularly by the observations of Defant\* that the sizes of raindrops are not arbitrarily distributed; the weights of drops of different sizes are in the ratios 1 : 2 : 4 : 8. This would suggest that only drops of equal sizes can coalesce. This peculiar behaviour of raindrops is not yet satisfactorily explained, but it may be, as W. Schmidt† has pointed out from hydrodynamic considerations, due to the fact that only drops of equal sizes can remain for a sufficiently long time close to each other during their downward journey, and thus facilitate the action of the hydrodynamic attractive forces between them.

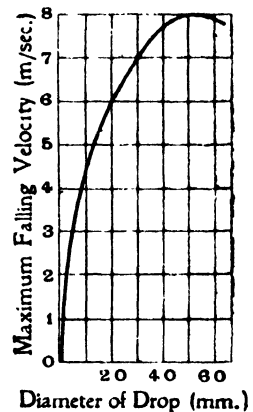

Fig. 35.—Observed maximum velocity of fall for drops of different sizes.

\* *Met. Zeits.*, p. 321 (1905).

† *Met. Zeits.*, p. 496 (1908).

The rate at which a raindrop, or any other object, can fall through still air depends upon its size. The relation between the terminal velocity and the size of the raindrops is shown in Fig. 35 on which some of the actual observations made by Lenard\* have been plotted.

We may consider this diagram in another way. The frictional resistance offered by the air to the passage of a drop depends upon the relative motion of the two, and it is of no consequence whether the drop is moving and the air is still or the air moving and the drop still, or both air and drop moving if they have different velocities. We see that beyond a certain point the terminal velocity does not increase with the size of the drops but tends to decrease. This is due to the fact that the drops become deformed, spreading out horizontally, with the result that the air resistance is increased. For drops greater than 5.5 mm. diameter, the deformation is sufficient to make the drops break up before the terminal velocity is reached.

An important consequence of Lenard's result is that no rain can fall through an ascending current of air whose vertical velocity is greater than 8 m/sec. In such a current the drops will be carried upward, either intact or after breaking up into droplets. There is good reason for believing that vertical currents exceeding this velocity frequently occur in nature.

On account of their inability to fall in an air current which is rising faster than their limiting velocity raindrops formed in these currents will have ample opportunity to increase in size, and the electrical conditions will usually be favourable for the formation of large drops. These large drops can reach the earth in two ways, either by being carried along in the outflow of air above the region of most active convection, or by the sudden cessation of or a lull in the vertical currents. The violence of the precipitation under the latter conditions may be particularly disastrous.

*Cloud burst* is a term commonly used for very heavy rain, usually associated with thunderstorms. Extremely heavy downpours are sometimes recorded, which in the course of a very short time tear up the ground and fill up gulleys and watercourses; this may happen at any place but occurs frequently in hilly and mountainous districts, where it may sometimes be due to the sudden cessation of convective movement, caused by the supply of warm air from the lower part of the atmosphere being cut off as the storm moves over the mountain range. With the cessation of the upward current, the raindrops and hailstones which it had been supporting must fall in a much shorter time than they would have done had the ascensional movement continued.

*Snow*.—When vigorous condensation begins to take place at a height at which the temperature is below 0°C. tiny crystals of snow are formed. The vapour is here directly

\* *Met. Zeits.*, p. 249 (1904).

condensed into ice. These crystals of snow reveal beautiful structures when examined under a microscope, and throw considerable light on their mode of formation. We cannot enter into this interesting subject here.

*Hail.*—The term properly denotes the hard pellets of ice of various shapes and sizes and more or less transparent, which fall from cumulo-nimbus clouds and are often associated with thunder and storms. A variety known as soft hail is small, white, opaque and soft, resembling little snow pellets.

Hailstones may attain a great size, stones as large as golf-balls have been observed in Europe and the recorded weights range up to a kilogramme (over 2 lbs.). Hailstones even larger than these are reported to have fallen in Bengal.

An important characteristic of a cumulo-nimbus cloud is the rapid ascent into it of a moist current of air, which is quickly cooled by reason of the reduced pressure which it encounters aloft. As the process continues cloud particles, and finally raindrops are formed, but if the ascensional velocity of the air exceeds 8 m/sec. all the condensed water is retained in the cloud. At a certain level the temperature has already fallen below the freezing-point. There is much evidence for believing that, at least in many cases, ice crystals are not immediately formed as soon as the temperature falls below freezing-point, but that water drops are still produced. These are in the super-cooled condition, and then they are carried upwards into the higher part of the cloud. Near the top of this cloud, however, ice crystals will appear and then will grow into pellets of soft hail by a process of condensation direct from vapour to ice. When the weight of a pellet is sufficient to overcome the resistance of the upward air current it will commence to fall. Let us consider the journey downwards of a pellet which has reached or is formed at the top of the cloud (8 km. say). It has to encounter a stretch of supercooled waterdrops and saturated air much exceeding 8 km. in length, because the air it meets is being carried upwards at a speed of, say, 8 m/sec. Wegener computes that the stretch of air



encountered may be as long as 14 km. The pellet is continuously passing into air warmer than itself and the temperature difference between the pellet and its surroundings increases continuously until the ground is reached, when in extreme cases the difference has been observed to be as much as 15°C. The air surrounding the hailstone, as the pellet has now become, is saturated with respect to the surface of the supercooled waterdrops which are floating in it, so that it is supersaturated with respect to ice at its own temperature and still more supersaturated with respect to the hailstone which as explained is at a still lower temperature. Consequently all the waterdrops held in suspension in the air, which the hailstone encounters on its way down, freeze on the stone immediately it strikes them. Wegener computes that the fall of a pellet from 8 km. to the ground under the conditions described is sufficient to account for the production of the largest hailstones. It may be noted that if the ascensional current fails or is considerably reduced in velocity, the suspended water in the cloud is no longer supported and it falls with the result described above as a cloud-burst.

## IX. DYNAMICS OF THE ATMOSPHERE

**97. Mean Wind Velocity.**—The calculation of the mean wind direction presents some difficulties because in this case we cannot take the arithmetic mean as is done in the case of temperature and pressure. The method usually employed for this purpose is as follows:—

At first the number of times, during the period under consideration, the wind has blown in each direction is determined. A circle is then drawn and its circumference divided into sixteen equal parts so that the radii joining the centre to the points of division of the circumference give the sixteen directions of the compass. Lengths proportional to the frequencies of the different winds are then drawn along the radii representing the corresponding directions. The diagram thus constructed is known as the *rose of wind-frequency*. From this diagram the mean wind can be determined easily by applying the rule of parallelograms in mechanics.

## RESULTS OF WIND OBSERVATION

**98. Diurnal Variation of Wind Direction and Force.--**

The diurnal variation of wind direction is not yet known for a sufficiently large number of good stations. The wind force shows a pronounced diurnal period, irrespective of the direction, at land stations. On the open sea, however, there does not seem to be any marked diurnal period of wind strength. The diurnal variation of wind strength in the lower layers of the atmosphere (a few feet above the ground) has the same character everywhere and can be described in the following way :—

The wind is weakest in the night, and freshens from 7 h. onwards and after 9 h. exceeds its daily average strength. The wind strength reaches its maximum at approximately the time of maximum temperature after which it decreases again. The amplitude of diurnal variation seems to be larger on clear than on cloudy days. These facts are clearly seen from Fig.\* 36 which represents the diurnal variation of wind force at a height of about six feet above ground at Agra in the different seasons. It will be noticed that the maxima of the curves for April and May (summer) as well as those for December and January (winter) are more or less sharp, while the maxima of the curves for July and August (monsoon season) are flat; moreover it will be seen that the amplitude of diurnal variation is greatest in the hot season. The maxima occur approximately at 14 h.

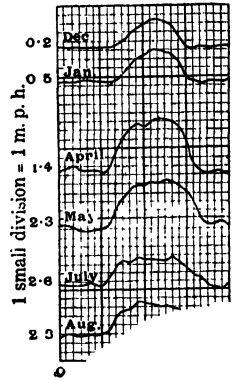

Fig.

The diurnal variation described confined to the lowest layers of the atmosphere. The diurnal variation of wind strength is not observed at the tops of mountains or in the upper atmosphere. It is strongest in the night at high altitudes.

All these peculiarities are explained with the concept of the diurnal variation of the wind force.

\* Taken from *Bark Department*, Vol. 25, part 1.

the early morning there are very often strong inversions of temperature in the lowest layers of the atmosphere; the layers nearest to the ground are the coldest, which is a very favourable condition for the stability of the atmosphere, so that the air is in a feeble stream-line motion. During the day, on the other hand, the layers adjacent to the ground become heated by contact with the ground; the equilibrium is no longer stable and the air is continually disturbed by eddies. The eddies carry air from upper layers, where the velocity is much greater, as we shall see later, to the lower layers, and the air from lower layers is carried to the upper layers; consequently the effect of the eddies\* is to decrease the strength of the wind at the upper layers and at the same time to increase the speed of the wind in the lower layers, in other words to produce a minimum in the former and a maximum in the latter.

**99. Annual Variation of Wind.**—Apart from its diurnal variation, the wind undergoes an annual variation both in speed and in direction. Here we shall describe briefly the annual variation of wind speed; while that of wind direction will be treated in connection with the general circulation of the atmosphere. The annual variation, unlike the diurnal variation, is different in different parts of the world. In the temperate regions the wind is generally stronger in winter than in summer, because in the former season the differences between one latitude and another are more pronounced; it is also in this season that storms† are the most frequent in Europe. The amplitude of the annual variation is larger in the coastal regions than in the interior of continents, and it is largest in regions where there are periodic winds, such as the monsoons. In the Indian Ocean the maximum of wind speed occurs during the south-west or wet monsoon period (July to September).

Observations made in all parts of the world show that the speed of wind increases with the height above the ground, though the increase is not proportional to the height. For the first 200 to 300 metres above the ground the wind speed increases very rapidly. At this height the effect of friction with the ground becomes negligible and the speed then increases slowly with the height. But it is often noticed during pilot balloon ascents that the balloon passes through several layers superposed on each other in which the velocities are very different. Sometimes the wind is strong at the surface, but weak in the upper layers and a calm is observed at a height of 2000 or 3000 metres. In spite of these irregularities, the observations show that, in general, the speed of the wind increases with height up to great heights. According to Ch. Maurain the wind speed continues to increase up to a height above 11 km. and continues to decrease up to a height of 20 km. where data are available. The velocity-altitude curve is shown in Fig. 1. The level of the tropopause. According to

\* *Abt. IIa*, Vol. 126, p. 757 (1917);  
Richardson, *Proc. Roy. Soc.*,  
Vol. 94, p. 152 (1918); Treloar,  
*Memoir No. 52*, Meteorol.  
and L. A. Ramdas, *Ind.*  
*Roy. Soc.*, Vol. 135, p. 678

to a more detailed study of W. Peppler\* who has used the data of aerological ascents made at Lindenburg, the bend occurs more and more above the level of the tropopause as the height of the tropopause increases above 11 km. When the tropopause is at 14 km. height, the maximum of wind speed occurs at 16 km.

The variations in the speed of the wind are often accompanied by changes in direction, which occur chiefly within the first two kms. and between 13 km. and 15 km. At Lindenburg the wind blows, in the annual average, from the west and shows a right-hand rotation from west towards north up to a height of 5 km. From 7 km. to 11 km. the direction remains constant, and in the stratosphere between 11 km. and 15 km. turns further to the north. In summer the direction is very uniform between WNW and NW up to great heights. In winter, on the other hand, the wind has, up to the level of the stratosphere, a slight southerly component and above 11 km. it even blows towards the north.

**100. Cause of Production of Wind.**—The principal cause of the production of wind is to be found in the differences in temperature which we observe on the surface of the globe or in the atmosphere. If there were no differences of temperature, there would be no air motion. The relation between temperature, pressure and the wind can be understood by the following example, the idea of which is due to Sprüng.†

Let us consider two columns of air AB, CD (Fig. 37) of which the pressures and temperatures are the same at the beginning and which are separated by a partition, but communicating at the level BD. The surfaces of equal pressure are at the same horizontal levels in both the columns, so that there can be no flow of air from one to the other. Now let the column CD be raised to a higher temperature. The pressure at the level BD remains the same in both the columns and so there is no flow of air from one column to the other; but in the column CD the successive levels of equal pressures are now more widely spaced than in column AB and at a certain

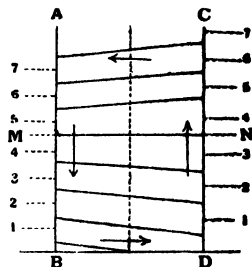

Fig. 37—Illustration of production of wind

\* *Arbeiten d. Preuss. Aeron. Observ. Lindenberg*. Vol. XIII (1919). See also A. Wagner, *Mel. Zeits.*, pp. 289, 329 (1923).

† Sprüng, *Lehrbuch der Meteorologie*, p. 108 (Hamburg 1885). See also Angot, *Traité de Meteorologie*, Paris, 1928.

height above the base BD the pressure in the warmer column has become greater than in the colder column. Now let us establish a communication between the tops of the two columns. Since at the same level near the top ends, the pressure is higher in column CD than in AB air will flow from CD to AB and consequently the pressure at the level BD in column AB will increase, so that air will flow from AB to CD at the base of the columns. If the difference of temperature between the two columns is maintained, a complete cycle will be established, the air flowing from the warmer to the colder column at the top and from the colder to warmer column at the base, as indicated in the figure. It will be noticed that there will be one neutral horizontal plane MN, where the pressure will be the same in both the columns; above the neutral plane the surfaces of equal pressure will slope from the warmer to the colder side and below the neutral plane the surfaces of equal pressure will slope in the opposite direction. The difference of temperatures at the surface thus produces along every horizontal plane a pressure gradient directed from the warmer to the colder side above the neutral plane and an opposite pressure gradient below it. This is the reason why during the day, when the land becomes hotter than the sea, the wind blows from the sea towards the land giving a *sea breeze*; and in the night when the land becomes cooler by radiation than the sea, the wind turns to the opposite direction giving a *land-breeze*.

In order to measure the pressure gradient or *barometric gradient* between two points, on the surface of the globe we have to draw the isobars (the isobars being the intersections of the isobaric surfaces with the horizontal plane) through the points. The two points being supposed to be on the normal to the two isobars, the barometric gradient between them is given by the ratio of the difference of pressure to the distance between the isobars measured along the normal. In practice the difference of the pressure is measured in millimetres of mercury and the distance in degrees of arc of the terrestrial sphere. A unit gradient, therefore, means a gradient of 1 mm. pressure per 1° of arc or 111·1 km. along the normal to the isobars.

The strength of the wind at a place depends on the barometric gradient in its neighbourhood. Observations show that weak winds correspond to gradients less than 1, and for a gradient of 4 or 5 the wind blows with storm force. It is clear therefore that a small gradient

can produce a large wind force. From what precedes it is evident that the barometric gradient between two points on the horizontal plane is the direct result of the inclinations of the isobaric surfaces passing through the points under consideration. A simple calculation will show that, even during the most violent storms, the force which produces the motion of the air, corresponds to a slope of the isobaric surfaces of the order of 1 : 10000.

**101. Influence of Earth's Rotation on Wind.**—In the above section we considered the effect of temperature differences in producing a barometric gradient and causing the motion of air. The general problem of the dynamics of the atmosphere is however one of extreme complexity and will therefore be touched upon here only in outline. The surface of the earth is far from being uniform; it consists of land and water surfaces which differ widely in their influence, mechanical as well as thermal, on air motion. Moreover water vapour, which is responsible for most weather phenomena varies irregularly from one part of the atmosphere to another. These and other disturbing factors make an exact solution of the problem practically impossible.

We shall consider a simple case in which no vertical motions exist and the air is moving horizontally with a linear velocity  $v$ . If the earth were plane and without any motion, the direction of the wind at each point would have been the same as that of the pressure gradient. But in reality the earth is round and is rotating with an angular velocity  $\omega = \frac{2\pi}{86164}$ , 86164 seconds being the length of a sidereal day, (the mean solar day being of length 86400 seconds). The linear velocity of any point on the equator due to rotation is  $r\omega = \frac{2\pi}{86164} \times 6378 \times 10^3 = 463$  metres per sec. The velocity of any point at a latitude  $\phi$  is  $463 \cos \phi$  metres. Under these conditions the forces acting on a particle of air at a latitude  $\phi$ , apart from any pressure gradient, arise from two causes: (1) the rotation of the earth and (2) the curvature of the path in which the particle is moving at the instant relative to the earth.

In consequence of the rotation of the earth, a particle moving above the surface with the velocity  $v$  is subject

to an additional acceleration. This is known as the Corioli's Force, after the name of the mathematician who was the first to give a clear mathematical idea of this force.

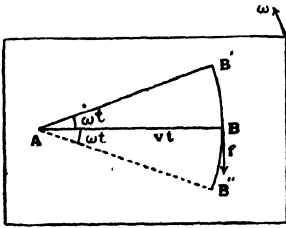

Fig. 38.—Illustration of the Corioli Force.

Suppose we have a plane disc rotating about the point A (Fig. 38) with the angular velocity  $\omega$ . Let us draw a line AB through A. In time  $t$  the point B will move to a point B' so that  $\angle B'AB = \omega t$ . Now a particle projected from A towards B which would have naturally described the line AB =  $vt$  will now appear from the earth to move along AB'' where  $\angle B''AB = \angle BAB'$  or  $BB'' = \omega t, AB = vt$ . The apparent displacement is proportional to  $t^2$  and we may therefore describe the state of affairs by saying that an apparent acceleration  $f$  acts on the particle. ' $f$ ' is easily seen to be  $2v\omega$  from the  $\frac{1}{2}ft^2$  law, and is perpendicular to  $v$  as well as to the axis of rotation. We can say that the force per unit mass is  $2 \times$  vector product of angular velocity of the disc and the particle velocity.

Let us now apply these considerations to the earth. The Corioli's force per unit mass parallel to the earth's surface due to earth's rotation is  $2v\omega \sin \phi$ , and is perpendicular to  $v$ . For at any point of the earth's surface (latitude  $\phi$ )  $\omega$ , the earth's angular velocity, can be resolved into two components—(1)  $\omega \sin \phi$  parallel to the radius vector, (2)  $\omega \cos \phi$  parallel to the meridian. The second term produces no horizontal Corioli force but a vertical force equal to  $2v\omega \cos \phi$ . The first term produces a horizontal Corioli force  $A = 2v\omega \sin \phi$ , which tends to deflect the wind to the right in the northern hemisphere as we look with our back to the wind. This is evident from the direction of ' $f$ ' in Fig. 38. In the southern hemisphere the deflecting force is to the left because  $\phi$  is here negative. Its magnitude is zero at the equator and increases steadily as we approach the poles.

As already mentioned the curvature of the path of the air particle gives rise to another apparent force, the well-known centrifugal force  $Z = \frac{c^2}{r}$  where  $r$  is the radius of curvature of the path and  $c$  the resultant velocity of the particle. The

centrifugal force is always at right angles to the direction of motion and, depending on the sense of the curvature of the path, may be in the same sense as the deflecting force  $A$  or in the opposite. Thus the total deviating force per unit mass of air in horizontal motion is given by

$$A + Z = 2c\omega \sin \phi \pm \frac{c^2}{r} \dots \dots (23)$$

In the middle and higher latitudes  $c$  is small compared to  $r$ , so that  $Z$  is small in comparison with  $A$ .\* In the tropical regions, however,  $A$  becomes less important than  $Z$  often during atmospheric disturbances.

The vertical component of the Corioli force deflects the west wind upwards and the east wind downwards. If  $c'$  is the westerly velocity component of the moving particle of air, then the vertical component of the deflecting force is given by  $A' = \pm 2 c' \omega \cos \phi$  the positive sign being for the west wind and the negative sign for the east wind.  $A'$  is maximum at the equator and decreases steadily with increasing latitude becoming zero at the poles.

In the above we have considered a single particle of air isolated from the mass of air in which it is embedded. Strictly speaking in studying the motion of air we should apply the methods of hydrodynamics rather than of the dynamics of a particle. Here however we shall only consider the dynamics of the particle in some simple cases.†

**102. Frictionless Horizontal Motion of Air.**—Let us employ the rectangular coordinates  $x$  and  $y$  lying in the horizontal plane of the place under consideration.  $x$  is measured towards the east and  $y$  towards the north, *i.e.*, along the meridian. For the limited region we can regard  $\sin \phi$  as a constant and can therefore write for the motion of the particle the Newtonian equation in the form

$$\left. \begin{aligned} \frac{du}{dt} - 2\omega \sin \phi \cdot v &= -\frac{1}{\rho} \frac{\partial p}{\partial x} + Z_1 \\ \frac{dv}{dt} + 2\omega \sin \phi \cdot u &= -\frac{1}{\rho} \frac{\partial p}{\partial y} + Z_2 \end{aligned} \right\} \dots \dots (24)$$

$\rho$  is the density of air, and  $-\frac{\partial p}{\partial x}$ ,  $-\frac{\partial p}{\partial y}$  the components of the pressure gradient.  $u$  and  $v$  are the velocities along the  $x$  and  $y$  axes respectively.

\* See Table 12, p. 465.

† For the detailed investigation of different cases from the hydrodynamical standpoint, see *Handbuch der Experimentalphysik*, Vol. 25, Part I, p. 84 *et seq.* See also Exner, *Dynamische Meteorologie*, 1925 and P. Raethjen, *Met. Zeit.* 1930, p. 431; *ibid.* 1931, p. 11 and p. 288; B. Haurwitz, *Veroff d. Geoph. Inst.* Leipzig, Vol. 5, part 1 (1913).



The second term represents the acceleration due to the earth's rotation while  $Z_1, Z_2$  the components of the centrifugal force.

**103. Steady Rectilinear Motion\***.—In the case of rectilinear motion  $Z=0$  and if further the motion be steady with constant velocity  $c$  we

have  $c = \sqrt{u^2 + v^2}$ , and  $\frac{du}{dt} = \frac{dv}{dt} = 0$ , so that

$$\left. \begin{aligned} 2\omega \sin \phi \cdot v &= + \frac{1}{\rho} \frac{\partial p}{\partial x} \\ \text{and} \quad 2\omega \sin \phi \cdot u &= - \frac{1}{\rho} \frac{\partial p}{\partial y} \end{aligned} \right\} \dots \dots (25)$$

The total pressure gradient  $\frac{\partial p}{\partial n}$  normal to the isobars is given by

$$\frac{\partial p}{\partial n} = \sqrt{\left(\frac{\partial p}{\partial x}\right)^2 + \left(\frac{\partial p}{\partial y}\right)^2}$$

also  $2\omega c \sin \phi = \pm \frac{1}{\rho} \frac{\partial p}{\partial n} \dots \dots (26)$

Thus for uniform rectilinear motion without acceleration, the pressure gradient per unit mass must be numerically equal to the deflecting force due to the earth's rotation but oppositely directed. The velocity  $c = G$  given by equation (26) is called

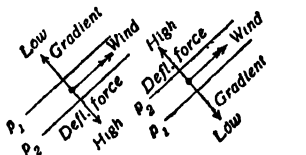

(a) North Hemi. (b) South Hemi.

Fig. 39 — Direction of wind in relation to pressure gradient.

It will be seen that the wind blows along the isobars  $p_1, p_2$  but at right angles to the pressure gradient; in the northern hemisphere the wind is inclined at  $90^\circ$  to the right of the gradient and in the southern hemisphere at  $90^\circ$  to the left of the pressure gradient. This

\* This case is of rare occurrence. However it may hold approximately also for cases where the radius of curvature is very large

follows directly from equation (25) if we regard  $v$  or  $u$  as the total velocity and  $-\frac{\partial p}{\partial x}$  or  $-\frac{\partial p}{\partial y}$  as the total gradient pressure.

In 1850 Buys-Ballot, after a careful study of the air circulation in storms, generalised a law of great practical value which is known after his name. Buys-Ballot's law states that for an observer standing with his back to the wind the low pressure lies on his left in the northern hemisphere and on his right in the southern hemisphere. The truth of this empirical law is evident from equation (26) and Fig. 39.

#### 104. Steady Horizontal Motion due to Curved Isobars.—

We shall now pass on to the case of curved isobars. The relation between wind velocity, pressure gradient, the deflecting force and the centrifugal force in the case of curved isobars will be easily understood from a consideration of the particularly simple case of circular isobars. We shall therefore consider this simple case.

Since the particle moves with steady velocity, *i.e.*, without any acceleration ( $\dot{r}=0, \dot{\theta}=0$ ) the forces acting on it are balanced. Now the deflecting force as well as the centrifugal force are perpendicular to the direction of motion of the particle, it follows that the only third force acting, *viz.*, the pressure gradient must also be perpendicular to the direction of motion of the particle. In other words the particle will move parallel to the isobars. Hence from Newton's equations of motion the centrifugal force must balance the sum of the deflecting force and the pressure gradient, *i.e.*,

$$-\frac{1}{\rho} \frac{\partial p}{\partial r} = 2 c \omega \sin \phi \pm \frac{c^2}{r} \quad \dots \quad (27)$$

The first term represents the pressure gradient per unit mass, the second term (the geostrophic component) represents the deflecting force due to earth's rotation, and the last term (the cyclostrophic component) represents the centrifugal force. The upper sign is used if the concave side of the isobar has low

pressure and the lower sign in the opposite case. These two cases correspond to cyclonic and anticyclonic curvatures of the isobars. It will be seen that in the northern hemisphere ( $\phi > 0$ ) for a clockwise rotation of the air the deflecting force is opposite in direction to the centrifugal force, while for an anti-clockwise rotation of the air the two forces are in the same direction. Now since the deflecting force is generally greater than the centrifugal force,\* its direction must be opposite to that of the gradient. It follows therefore that in the northern hemisphere when the pressure is low at the centre, the rotation of air must be in the anti-clockwise direction as is actually found in *cyclones*; on the other hand the rotation must be clockwise when the pressure is high at the centre as is the case in *anticyclones*. For the southern hemisphere the conditions are just reversed since the sign of  $\phi$  becomes changed and hence also the direction of deflection. The relation between the gradient, the deflecting force, the centrifugal force and the wind velocity is represented diagrammatically in Fig. 40 for both the hemispheres and for clockwise as well as anti-clockwise rotation of the air.

It will be seen that in all the four cases represented in the figure the direction of the wind and of the gradient are in accordance with Buys-Ballot's law as we saw in the case of rectilinear isobars.

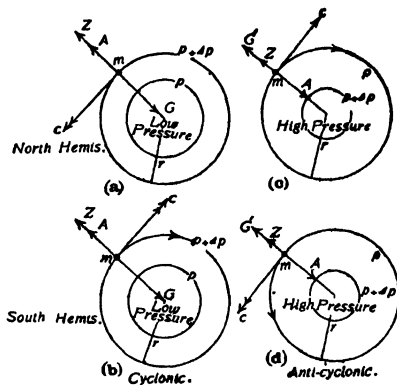

Fig. 40.—Direction of wind and pressure gradient in cyclones and anticyclones.

The deflecting force  $A$  has been drawn, in all cases, greater than the centrifugal force  $Z$ . With the help of the relations deduced above, the values of  $A$  and  $Z$  can be calculated for given values of  $c$ ,  $\phi$  and of the radius of curvature  $r$ , and are given in Table 12.†

\* See table 12, p. 465.

† Taken from Exner, *Dynamische Meteorologie*.

Table 12.—Values of  $A$  and  $Z$  calculated for certain values of  $r$ ,  $\phi$  and  $c$ .

$c$ in m/sec	$A$ in $\text{cm/sec}^2$					$Z$ in $\text{cm/sec}^2$			
	$\phi=10^\circ$	$\phi=20^\circ$	$\phi=40$	$\phi=60$	$\phi=80$	$r=100$ km	$r=500$ km	$r=1000$ km	$r=2000$ km
5	0.013	0.025	0.047	0.063	0.071	0.025	0.005	0.003	0.001
10	0.025	0.050	0.093	0.126	0.143	0.100	0.020	0.010	0.005
20	0.051	0.100	0.187	0.252	0.286	0.400	0.080	0.040	0.020
30	0.076	0.149	0.280	0.378	0.430	0.900	0.180	0.090	0.045
40	0.101	0.199	0.374	0.504	0.573	1.600	0.320	0.160	0.080

The general theoretical conclusions considered above are, on the whole, supported by meteorological observations; but for an agreement in details of theory and of observations, the effect of the friction of air with the earth must be taken into consideration in the theory. The foregoing considerations also explain the absence of closed "highs" in the equatorial regions. We see from equation (27) that at the equator ( $\phi=0$ ) there is no deflecting force due to the earth's rotation, so that there is no force to counterbalance the outward directed gradient characteristic of a "high." Thus closed "highs" or anticyclones are peculiarities of extra-equatorial regions.

**105. Friction between Earth and Atmosphere.**—We have seen that in frictionless steady motion the wind must be at right angles to the gradient. But on synoptic charts we find that the wind makes an angle less than  $90^\circ$  with the gradient even when the steady state has been attained. This is due to the friction between the earth and the atmosphere. In regions of cyclonic motion we find that there is a motion towards the area of low pressure; this is possible only when the gradient is greater than the deviating force, *i.e.*, when  $A+Z < G$ , so that there ought to be an acceleration in the direction of the gradient. But since in spite of this acceleration the motion remains steady, there must be a constant frictional force between the air and the earth which opposes it. The quantitative mathematical study of the effect produced by this frictional force is complicated and the interested reader may refer to the papers of Guldberg and Mohn\* and of Hesselberg†. The investigations show that near the earth's surface the wind direction makes an angle smaller than  $90^\circ$  with the pressure gradient. The angle increases with the height and attains the value of  $90^\circ$  at a height of about 300 metres showing that the effect of friction has become negligible.

\* *Zeits. d. Ost. Ges. f. Met.*, p. 51 (1877).

† *Veroff. d. geophys. Inst. der Universitat, Leipzig*, second series, Vol. 7 (1915); also *Geofysiske Publikationer*, Vol. III, No. 5, Oslo, 1924,

## X. GENERAL CIRCULATION OF THE ATMOSPHERE

**106. Trade Winds.**—With the aid of the preceding notions we can proceed to study the general circulation of the atmosphere. We shall first assume that the earth is a regular sphere with a uniform surface structure, and that the sun remains always in the plane of the equator. The temperature being maximum at the equator, every point of this great circle will behave as a hot centre so that at the equator there will be a minimum of pressure at the lower levels (*cf.* Fig. 37) and a maximum at the higher levels. Moreover, there will be an upward movement of air at the equator; at the lower levels air will converge towards the equator from both sides and at the higher levels air will diverge from the equator. In consequence of the rotation of the earth these movements will be deviated towards the right in the northern hemisphere, and to the left in the southern hemisphere it being understood whenever we talk of right or left, that we place ourselves with our back to the wind. At the lower levels, therefore, the winds will be NE instead of N in the northern hemisphere and SE instead of S in the southern hemisphere. These regular winds blowing towards the equator are known respectively as the North-East and South-East *trade winds*.

**107. Doldrums and the Easterly Current.**—At the equator itself at lower levels there is a comparative calm so far as horizontal motion is concerned; this is because here the pressure is minimum and the horizontal pressure gradient becomes zero. This equatorial belt of calm is known as the *doldrums*. The heated air at the surface of the earth at the equator has an ascending motion and has no horizontal motion relative to the surface of the earth.

But a particle of air at the earth's surface at the equator is moving with the same absolute velocity from west to east as the earth itself. A particle of air at a higher level vertically above the equator is, however, describing a circle of larger radius (*viz.*, radius of earth *plus* height above equator) in the

same sidereal day, and therefore, has a larger west to east velocity. Consequently the particle of air ascending vertically from the equator will lag behind its neighbours during its upward motion, and will appear to have an east to west motion, giving rise to the easterly current above the equator. The easterly component will increase in intensity with increase of height above the equator; and the ascending air will spread towards the poles deviating progressively to the right in the northern hemisphere and to the left in the southern hemisphere

**108. The Three Systems of Circulation.**—The circulation pictured above was at first supposed to be true for the whole hemisphere (Hadley, 1735). But later (Ferrel, 1850) it was found that the strength of winds due to this circulation would be much greater than that actually observed. It was found that there is no direct exchange of air between the equator and the poles. The atmosphere of each hemisphere is subdivided into two or three zones with independent circulations, *viz.*, (1) between the equatorial low and the tropical highs, (2) between the equatorial tropical belts (known as the horse latitudes) and the polar circles, this circulation being called the *prevailing westerlies* and (3) possibly a circulation of the polar caps.\* The general circulation of the atmosphere according to Hildebrandsson is represented diagrammatically in Fig. 41.

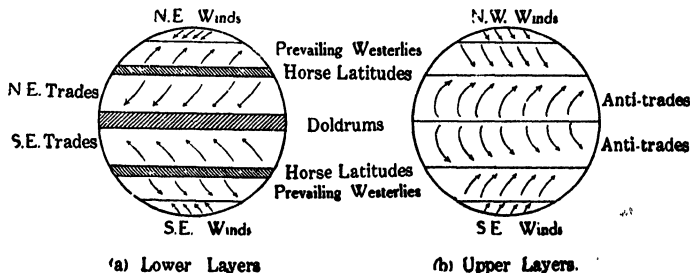

Fig. 41—General circulation of the Atmosphere.

**109. Circulation between the Equator and the Tropical High Pressure Belt. The Anti-Trades.**—As we have said above,

\* See "*Memoires Originaux sur la circulation générale de l'atmosphère*" (Halley, Maury, Ferrel, Von Helmholtz) compiled by M Brillouin (Paris, Gauthier-Villars.)

near the surface at the equator there is a comparative calm (doldrums), but there is a strong easterly current at upper levels. These easterlies experience on account of difference of temperature between equator and higher latitudes a component force urging them towards the poles. During this motion they are deflected to the right in the northern hemisphere and to the left in the southern hemisphere. In the northern hemisphere these winds gradually turn to west through south and constitute the S. W. anti-trade winds at high altitudes and feed the high pressure belt of the tropic of cancer. In the southern hemisphere the easterly current gradually turns to west through north and constitutes the N. W. anti-trades at high levels and thus feeds the high pressure belt of the tropic of capricorn.

These winds are called the *anti-trades* because they flow at higher levels in directions opposite to the trades at low levels.

#### **110. The Horse Latitude and the Prevailing Westerlies.—**

These anti-trades on reaching the tropics descend in part; the other part enters the middle latitudes and in its poleward journey, is again acted upon by the deflective force due to the earth's rotation, which turns it through west to north-west in the northern hemisphere and to south-west in the southern hemisphere. Thus, in the higher levels, the tropics are fed from the polar side by north-westerly (northern hemisphere) and south-westerly (southern hemisphere) winds, and from the equatorial side by south-westerly (northern hemisphere) and north-westerly (southern hemisphere) anti-trades, giving rise to the tropical belts of high pressure in latitudes  $30^{\circ}$  to  $35^{\circ}$  known as the *horse latitudes*.

#### **111. Circulation between Tropical High Pressure and the Polar Circle.—**

The existence of the high pressure belts at the tropics gives rise to air movements in the lower levels from the tropics towards the middle latitudes. These currents are also affected by the earth's rotation and appear as south-westerly winds in the north temperate zone, and as north-westerly winds in the south temperate zone. The winds of the tem-

perate zones thus have a prevailing westerly component both at the surface and aloft, and are therefore called the *prevailing westerlies*. The prevailing westerlies are often very powerful, the region of their occurrence in the southern hemisphere being well-known to sailors as the "roaring forties."

Within the polar circles the circulation at the upper levels seems to be from the northwest round the north pole and from the southwest round the south pole; but at the surface the circulation has an easterly component.

**112. Modifications of the Typical Wind Systems.**—The general circulation of the atmosphere described above represents naturally average conditions and is subject to variations due to two causes. Firstly the axis of the earth is inclined at  $23\frac{1}{2}^{\circ}$  to the plane of the ecliptic which introduces a change in the presentation of the globe to the rays of the sun. On account of this the equatorial belt of high temperature migrates and therefore the equatorial belt of low pressure also migrates. This causes the permanent wind systems of the globe to migrate; the migration of the wind system lags about two months behind the migration of the sun and, on the average, covers a distance of 5' to 6'. Secondly, the earth's surface is very diversified, being composed of land and sea, of high mountains and low plains. This diversity of surface also affects the typical wind systems. Up to latitude  $45^{\circ}$  the continents are on the average, hotter than the seas; consequently the pressure is lower on the surface of the continents of low latitudes than on the seas. The difference of temperature between land and sea at latitude  $30^{\circ}$  or  $35^{\circ}$  is much greater in summer than in winter, so that in the northern hemisphere which is composed of large continents the maximum of pressure over the seas and the minimum over the continents are very pronounced in summer. In the South Atlantic the seasonal variations of pressure distribution are much less marked owing to the scarcity of land.

In the equatorial regions the difference of temperature between land and sea is at its maximum and remains practically constant throughout the year, so that the wind blows always from the sea to the land which is hotter.

Another cause of perturbation of the general circulation of the atmosphere is that the geographical equator and the thermal equator do not coincide. In the northern hemisphere the thermal equator is to the north of the geographical equator particularly over Africa, so that the equatorial calms, which separate the trades of the two hemispheres, are to the north of the geographical equator even in winter. Moreover the thermal equator is not stationary; it follows the movement of the sun, so that in summer the south-east trades of the southern hemisphere penetrate to the north of the geographical equator. Thus the limit of the trade winds ascends or descends in latitude with the sun, and in some cases there may be complete reversal of atmospheric circulation from winter to summer or *vice versa*.



**113. Monsoons.**— We have said that in summer the continents are hotter than the seas; the opposite takes place in winter. The large continents thus behave as cold centres in winter, and as hot centres in summer; the oceans on the other hand, behave as hot centres in winter and as cold centres in summer. Consequently if the general circulation were not present, there would have been a cyclonic regime in summer and an anticyclonic regime in winter over the large continents and the opposite over the oceans. There would thus be a periodical reversal of the wind system with the seasons. These periodic winds are known as the *Monsoons*.

The complete reversal of the winds with change of seasons can take place only in certain regions where the differences of temperature between

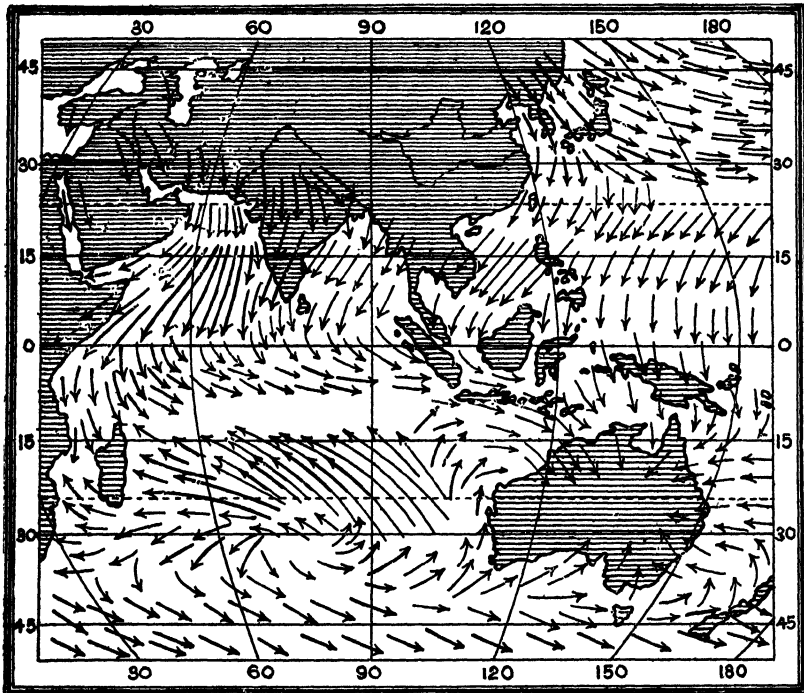

WIND SYSTEM OF JANUARY-FEBRUARY

Fig. 42

land and sea in winter and in summer are large enough to overpower the general circulation. This is what happens over the large Asiatic continents. In winter the temperatures are extremely low considering the latitude, and the pressures are very high, being more than 776 mm. in the north-east. Over Asia in winter there is thus a gigantic anticyclone with air descending to its centre and diverging all round towards the oceans. This is clearly seen on the climatological charts (Fig. 42) of

**115. Structure of a Depression.**—The real nature of a depression is not yet completely known. At the surface of the earth and in the lowest layers of the atmosphere a depression appears, under the influence of the gradient, the deflective force due to the earth's rotation, the centrifugal force and the virtual friction, as a system of converging currents which consists on the one hand of a whirl and on the other of a translatory motion. Investigations on the paths of given masses of air, the so-called trajectories,\* during a long period have furnished indications of a spiral motion of air round the centre of a depression; it has been found that a cold mass of air, which has formed part of a depression for a certain length of time, separates itself and joins the circulation of a newly evolved depression. In any case, a depression should not be regarded as a whirling mass of air moving *en bloc* in a certain direction. The air forming a depression has a translatory motion, it can influence the direction of propagation of the depression, and it is also understandable that, under special circumstances the direction of propagation of the depression can be entirely different from that of the general current.

As has already been mentioned, the distribution of wind in different parts of a depression is not symmetrical. In fact it is found that in certain zones of the depression the wind direction changes discontinuously and in the same zones discontinuities of temperature distribution are also noticed. In the front part of a depression (of the northern hemisphere) moving from west to east the wind is southerly and is warmer than that of the rear part. These warm and cold masses of air forming parts of the depression are separated by surfaces of discontinuity and flow sometimes side by side, sometimes against each other and sometimes partly one above the other.

Bigelow† was the first to recognise the role which warm and cold air currents play in the formation of regions of abnormally high or low pressure. In 1902 he said that due to

\* See Shaw and Lempfert, *Life History of Surface Air Currents*, M. O. London, 1906.

† *Monthly Weather Rev.* 1902, p. 251.

the interaction of the upper westerly current and the lower countercurrents with northerly or southerly components cyclonic motions are produced. Margules further improved the theory and showed that a "low" (depression, cyclone or tornado) is composed of a cold and a warm current of air.

In 1919 Bjerknes\* gave a diagram of an idealised cyclone which led to a clear understanding of the boundaries between the warm and the cold currents. In this structure two surfaces of discontinuity inclined to the horizon were distinguished, the intersections of which with the horizontal

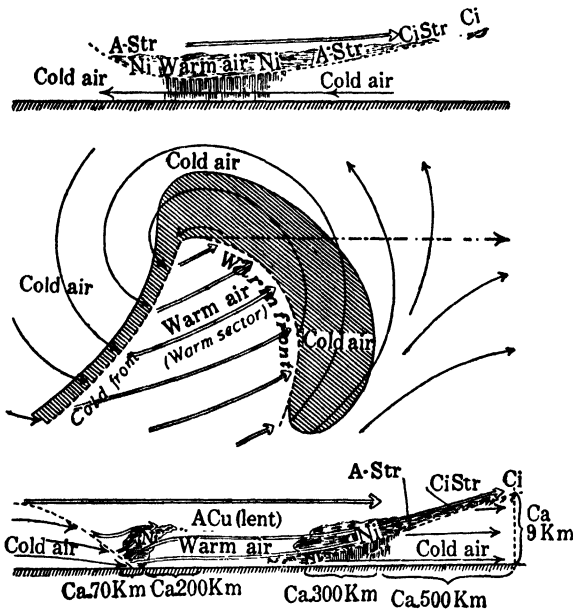

Fig. 46.—Structure of an idealised cyclone.

plane were called the *squall-line* which is the line of discontinuity lying southwards from the centre of the low and the *steering-line*, which is the line of discontinuity on the northern side. The term steering-line being not free from ambiguity was later changed to *warm front* and the squall-line changed to *cold front*. Fig. 46 reproduced from Bjerknes and Solberg's paper gives the structure of an idealised depression (cyclone).

In European latitudes when the west-east track of a depression lies on the north of an observing station, the succession of phenomena

\* *Quart. Journ. Roy. Met. Soc. London*, Vol. 46, No. 194, also *Geofysiske Publik.*, Vol. 1, No. 2.

† See J. Bjerknes and H. Solberg, *Geofysiske Publik.*, Vol. 2, No. 3 (1921).

observed is exactly the same as that due to the passage of a warm front followed by a cold front. A depression is essentially composed of a tongue of warm air inserted within a mass of cold air. Both the air masses belong to the general circulation; the one from the north-east is of polar origin and therefore cold and dry, while the other from the south-west is of tropical origin and therefore warmer and moister. The tongue of warm air is separated from the cold air by a warm front on the east and by a cold front on the west. On the eastern side of the warm sector the tropical air rises above the heavier polar air and gives rise to the precipitation characteristic of a warm front, while on the western side the cold air attacks the warm sector and produces the bad squally or stormy weather characteristic of the passage of a cold front. The shaded area in Fig. 46 represents the area of rainfall at the moment of observation. The successions of phenomena, observed at places situated on the south of the trajectory of the centre of the depression and at places on the north of the trajectory, are different owing to the fact that on the northern side the surface of discontinuity does not meet the surface of the earth. The lower part of Fig. 46 gives a vertical section through the depression to the south of the centre and represents from right to left the succession of weather to the south of the passing depression. "First\* the passage of typical warm-front rain preceded by a huge shield of cirrus, cirro-stratus and alto-stratus clouds. Then a relatively warm spell of weather, with only occasional showers, the warm sector during which the cloud shield of alto-cumulus appears, announcing the approaching cold-front rain. After the passage of the cold-front rain, cool and, under certain circumstances, showery weather persists till the final clearing." The succession of phenomena to the north of the track of the depression is represented in the upper part of Fig. 46 (from right to left) sketching a vertical section through the depression to the north of the centre. "Such\* a section cuts the rain area only once, corresponding thus to a single rainfall of duration according to relative distances from the centre. This rainfall is of the warm-front type and is preceded by the same sorts of clouds. The rain ceases by and by simultaneously with a gradual elevation of the cloud cover."

According to Bjerknes the surface of discontinuity should extend up to all heights where the polar air is colder than tropical air, *i.e.*, practically throughout the whole troposphere. The experimental confirmation of this is however yet lacking.

**116. Evolution of a Depression.**— In sec. 108 we saw that in the northern hemisphere near the surface of the earth at the polar circle the cold north-easterly (or easterly) winds from the polar region meet the warmer southwesterly (or westerly) winds of middle latitudes. The surface of separation between the two currents of unequal temperatures has been called by V. Bjerknes the *polar front*. This polar front is not a

\* These quotations are taken from J. Bjerknes and H. Solberg's paper, "Meteorological conditions for the formation of rain," *Geo. Pub.*, Vol. 2, No. 3.

perfectly steady or regular boundary between the polar air from the lower latitudes; but wherever it is present there is a pronounced discontinuity in the horizontal distribution of temperature and in the wind direction. According to Bjerknæs the

depressions of the temperate zone have their origin in this polar front. We have seen that under normal circumstances there cannot be any direct exchange of air between the equator and the poles; this exchange of air between the equator and the poles is brought about slowly by means of the cyclonic disturbances of the temperate zone.

The different phases in the evolution of a cyclonic depression on the polar front can be understood from the diagrams in Fig. 47.

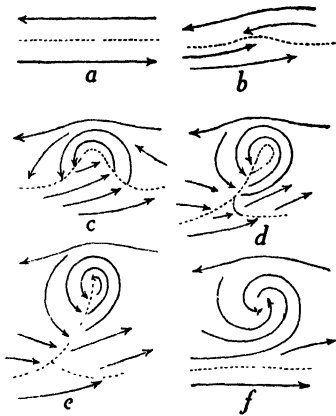

Fig. 47.—Evolution of a depression.

In (a) the cold polar current is flowing from east to west and the warmer current of the middle latitudes is flowing from west to east; the polar front is represented by the dotted line. Since the westerly current is stronger than the easterly current, the inclination of the polar front with the horizon is towards the north. The warm air will therefore penetrate into the cold air and the polar front will assume the form shown in (b). The deformation of the polar front will continue and the tongue of warm air will become longer in the north-south direction as shown in (c) and (d). It will be noticed that, as the warm sector becomes longer, its width decreases. (c) represents a full grown depression with its warm and cold fronts as in Fig. 46. In (d) already the warm and cold fronts have come very near each other. This shrinking of the warm sector continues till the supply of warm air is completely cut off when the depression is said to be *secluded*. The only warm air present in this stage of the depression is that at the centre. This however soon rises, so that the depression contains nothing but cold air and is said to be *occluded*.

There are two distinct stages in the life of a depression, *viz.*, the stage before occlusion and the stage after it. In the

first the depression is young, its kinetic energy goes on increasing and the depression intensifies. In this stage its translatory motion also increases. In the second stage the depression is old, its constituents namely the warm and cold masses of air, become more and more homogeneous, its kinetic energy decreases till finally it dies.

The above view as regards the evolution of a depression has been given by Bjerknæs\* and is based on what is known as Bjerknæs' Wave Theory of cyclones. According to this waves are produced on the polar front and every one of these waves develops into a cyclone. Thus we get a series or *family of cyclones* on the polar front separated by wedges of high pressure or even closed anticyclones. A cold polar wave generally produces from 2 to 6 depressions in succession, each forming to the south-west of its predecessor. When the cold air has thus gone far to the south, its temperature becomes equal to that of the air of the temperate zone, so that further formation of depressions becomes impossible. Then begins another cold wave and produces another series of cyclones.

The cold waves are nothing but such huge masses of cold air, which under certain conditions collapse southwards and sometimes reach even the subtropical regions. They are of great consequence in North America, because in their southward course they often penetrate into the southern states and cause considerable damage to the crops. In north-west India, particularly in the Punjab, they may come in with depressions of extratropical origin, known as *western disturbances*.

According to Bjerknæs the cyclones of the extratropical regions are the results of a wave motion started on the polar front. Even if we leave aside the delicate question of the genesis of the wave motion, which is probably of a gravitational nature, we find that the distances between the cyclones of a family are much larger than the lengths of the waves, which one would expect from the hydrodynamical point of view on the surface of separation (very slightly inclined to the horizon) between the polar and equatorial currents. This difficulty, pointed out by Exner, is not completely solved even by taking account of the compressibility† of the air. Apart from mathematical difficulties there is the observed fact that the polar front cannot always be regarded as a sharp surface of discontinuity; according to Sandström it is rather a wide zone of discontinuity in which the air is disturbed and therefore cyclones may originate in it in the same way as revolving vortices appear in flowing water. There is however the important fact that depressions are known in which although the marked temperature contrasts, which Bjerknæs' theory would require, are absent in the lower levels, they are present in the free atmosphere slightly higher up.

Exner has proposed an alternative picture of the origin of cyclones, which may be called the "barrier theory." According to this a depression

\* *Geofysiske Publik.*, Vol. II, No. 4, Oslo (1921). *Geofysiske Publik.*, Vol. III, No. 3. (1923).

† V. Bejerknæs, *Geof. Pub.*, Vol., III, No. 3, Christiania, 1923.

is formed in the same way as whirls are set up in a river by a solid barrier projecting from the bank. In the atmosphere the barrier need not be solid but may be just the mass of cold air freely flowing down towards the south between a cyclonic and a westward-lying anticyclonic centre of action. This idea seems to be better suited to explain the characteristics of the primary or mother cyclone, but in the later stages Exner's theory becomes practically the same as Bjerknes' theory. The Austrian school has preferred the barrier theory while the Norwegian meteorologists, particularly J. Bjerknes, H. Solberg, and T. Bergeron, have developed the wave theory from the point of view of practical weather analysis. The Norwegian method of analysis has achieved striking successes and its merits are now recognised by all meteorologists who are engaged in the analysis of weather charts. The mathematical treatment of the problem of evolution of depressions based on either of the above theories is far from being complete, but in practical meteorology this is of little consequence.

We have seen that in extra-tropical depressions cold and warm masses of air lie side by side, the cold and warm samples being separated in the horizontal plane by the cold and warm fronts. In space the two air masses are separated by two surfaces of discontinuity, which are inclined to the horizontal plane in such a way that the heavier cold air is underneath the lighter warm air. Even in the absence of a depression two currents of air of unequal temperatures can flow side by side for a considerable length of time, without materially reacting on each other, that is to say, the surface of discontinuity remains stable. The conditions of stability of the surface of discontinuity were investigated first by Helmholtz, but his investigations remained unknown to meteorologists for a long time. In 1906 Margules\* carried Helmholtz's investigations further and in 1921 V. Bjerknes † showed the importance of the surface of discontinuity in weather phenomena. According to Margules the condition of stability of the surface of discontinuity is given by

$$\tan \alpha = - \frac{2 \omega \sin \phi}{g} \cdot \frac{v_1 T_2 - v_2 T_1}{T_2 - T_1},$$

where  $\alpha$  is the inclination of the surface of discontinuity to the horizontal plane,  $v_1$  and  $T_1$  are the average velocity and temperature of the cold air, and  $v_2$  and  $T_2$  the average velocity and temperature of the warm air; as usual  $\omega$  is the angular velocity of the earth's rotation,  $\phi$  the latitude, and  $g$  the acceleration due to gravity. It is clear from the above equation that a change in the velocity difference or temperature difference between the two air masses will produce a change in the inclination of the surface of discontinuity. Thus if the changes are such that the inclination decreases, the cold air will push forward into the warm region; in the opposite case the cold air will shrink back, and the warm air will push forward into the cold region. In the first case there will be a *cold wave*, and in the second there will be a *heat wave*.

**117. Theory of General Circulation based on Polar Front Theory.**—The polar front theory leads also to a theory of the general circulation of the atmosphere which gives precision to the features of the

\* Hann, *Band der Met. Zeit.* (1906), p. 243.

† *Geofysiske Publikationer*, Vol. 2, No. 4, Oslo (1921).

general circulation indicated before. According to this theory the troposphere in each hemisphere, is divided into three principal circulations:

1. A tropical circulation A (Fig. 48) closed at the lower levels by the trades and at the higher levels by the anti-trades. This circulation consists of an ascending motion on the equatorial side and of a descending motion on the opposite side.

2. An extra-tropical circulation B extending from the tropics to the polar front. The direction of motion in this circulation is opposite to that in A so that the motion is ascending on the polar side and descending on the other. At the lower levels the current is southwesterly and at the upper levels it is northwesterly.

3. A polar circulation C fed by intermittent waves of tropical air V. The air of the polar cap intermittently flows towards the equator and mixes with the southwesterly current of the temperate zone, by means of cyclones  $C_1, C_2, C_3, C_1', C_2', \dots$  and with tropical air by means of polar waves W.

These circulations give two zones of ascending motion and consequently of great precipitation, one along the equator and the other near the polar front; and further two zones of descending motion where very limited precipitation should be expected, namely, a zone round the pole, and the zone of the sub-tropical calms.

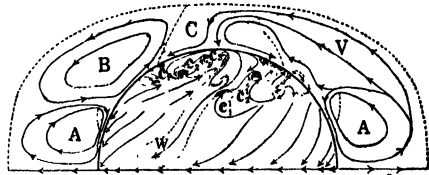

Fig. 48 —General atmospheric circulation based on Polar front theory.

**118. Anticyclones of Temperate Zones.**—It often happens, particularly in winter, in middle latitudes that one observes a more or less large area with a distribution of pressure and wind exactly opposite to that in a depression. The pressure is highest at the centre and decreases all round it, so that the isobars are more or less circular. At the lowest levels the winds rotate in the clockwise direction in the northern hemisphere and diverge on all sides from the centre. At a certain level above the surface of the earth the winds, on the contrary, converge towards the centre; consequently there is a descending motion of air in the centre of an anticyclone. This descending motion of air is the cause of fair weather which is characteristic of an anticyclone.

Anticyclones have generally much larger dimensions than depressions; and the gradient of pressure is smaller in anticyclones than in depressions so that the winds are also weaker.



The character of an anticyclone can be quite different according to the cause of its origin. Sometimes it appears as an intermediate region of high pressure between two moving depressions; in this case it is composed of cold polar air and gives a sort of stability to the depressions which it separates. Sometimes an anticyclone may have an existence quite independent of any depression. Such anticyclones are often observed in Europe and are of exceedingly large dimensions. The cause of the origin of these, more or less stationary, anticyclones is not yet known with certainty; probably they are produced when two large regular currents with moderate velocities conyerge in the higher regions of the atmosphere. In the region of meeting of the two currents there is an accumulation of air and consequently an elevation of pressure with descending motion of air. Such anticyclones are attended with remarkably steady weather. The air descending slowly towards the ground loses by radiation the greater part of the heat evolved due to compression, and consequently produces no great change in temperature; the sky is remarkably clear at a certain height. These conditions may continue down to the ground if it is cold and dry; but if the ground is warm and humid, the cooling due to radiation causes the moisture in the air to condense and the supply of moisture is constantly replenished by evaporation; a sheet of stratus is thus formed and the sky looks overcast although there is no rain.

Finally, there is another class of anticyclones which form due to local influences, such as an extremely low temperature of the ground. The gigantic anticyclone which forms over Central and East Asia in winter is of this type. The characteristic of such anticyclones is that the sky remains perfectly clear and the temperature extremely low due to free radiation, so that the diurnal variation of temperature has a large amplitude.

**119. Tropical Cyclones.**—Tropical cyclones are vast whirls in the atmosphere in which the wind blows round and spirally

inward towards a central region of extremely low pressure. In the northern hemisphere the air circulates counter-clockwise round the low pressure and in the southern hemisphere it circulates clockwise. The winds in a fully developed cyclone nearly always attain destructive velocities in a ring of hurricane winds surrounding the centre. They develop a large cloud area from which rain pours down in torrents. These storms, technically known as tropical cyclones because they originate within the tropics, have various names in different parts of the world. They are usually called *hurricanes* in the West Indies, *typhoons* in the China Sea, and *baguios* in the Philippine Islands.

These storms have a progressive movement, the storm field advancing on a curved or, sometimes, a straight track. Their velocity of movement averages about two to three hundred miles per day. Generally, during curving, the rate of advance of storms decreases considerably.

In the front of a tropical cyclone the sky is covered with high clouds, in which halos sometimes appear. The air becomes sultry and oppressive; the wind falls almost to a calm and on the ocean a heavy swell rolls up. In the next stage, a breeze springs up, the clouds become lower and heavier, and pressure begins to fall. Afterwards heavy rain clouds appear, first on the horizon, and then advance across the sky; as the rain clouds pass overhead, the rain falls in torrents. The wind becomes fiercer, while the barometer falls rapidly. High or tremendous seas are superimposed on the heavy swell. The sea spray and rain destroy all visibility. When the wind has reached its greatest violence, suddenly the centre of the storm arrives. Here the wind suddenly drops from hurricane force to light unsteady breeze, or sometimes to a complete calm. At the calm centre the lowest pressure is recorded and often there is a complete absence of low cloud and rain; the sun, moon or stars may be visible according to the time of the day when the calm centre is traversed. Following the passage of the centre, the wind suddenly increases to hurricane force again but from the opposite direction the torrential rain is renewed and the barometer rises as quickly as it fell. As the end of the storm approaches the wind falls and the rain clouds break and disappear, bearing only high clouds. Finally, the wind drops, the sky clears and pressure becomes normal.

The calm centre is sometimes called by seamen the "Eye" or "Vortex" of the storm. A striking feature of the Eye is the presence of grasshoppers and butterflies, and sometimes land birds, which have been sucked into the whirl and are dead or in a state of complete exhaustion. The eye of the

storm is often almost as dangerous for navigators as the surrounding ring of strongest winds, because at the centre the sea is excessively turbulent and high owing to the "churning" action produced by heavy swell arriving from all sides of it.

Thus there are no fundamental differences between the tropical cyclones and the depressions of the higher latitudes. In fact, very often a gradual passage from the cyclonic stage to the depression stage or *vice versa* is observed; some cyclones, which reach the Antilles, travel towards the north-east along the coasts of America and become absolutely indistinguishable from depressions of the temperate zone. The differences in details between the tropical cyclones and the depressions of higher latitudes can be summarised as follows:

The diameter of a tropical cyclone is generally less than that of a depression, and the pressure gradient is generally higher in the former. A tropical cyclone is therefore attended with more violent winds. In both, the wind force increases progressively as we approach the central regions, but at the centre of a tropical cyclone there is the region of calm or light variable winds. The cyclone which devastated the Bay of Bengal on the 1st of November, 1876, had a calm centre of which the diameter was only 24 km. to 28 km.

The motion of air in cyclones is similar to that in depressions. At the surface of the earth the air converges from all sides towards the centre and rises spirally along the axis of motion. At a certain height the motion becomes divergent so that the air is thrown out of the whirl. In the circular zone of violent winds which surround the central calm, the sky is completely overcast with dense clouds from which rain pours in torrents. This is due to the vigorous updraft of air in this zone. The explanation of the clear sky in the eye of the storm is not certain; but probably it is due to a momentary descent of air from above, caused by the partial vacuum in the central calm. If the air descends down to the ground, a temporary rise of temperature and a decrease of humidity should occur; this sudden rise of temperature and fall of humidity were observed at Manilla on the 20th October, 1882.

Tropical cyclones occur over the warmer portions of all oceans except, possibly, the South Atlantic. They are most numerous in (1) West Indies, the Gulf of Mexico and the Coast of Florida, (2) the China Sea, Philippine Islands, and Japan, (3) the Bay of Bengal and the Arabian Sea, (4) east of Madagascar near the Islands of Mauritius and Reunion and (5) east of Australia near Samoa. Tropical cyclones never originate on land and if they run ashore they weaken and lose much of their destructive violence. They form in the doldrums where convectional rain is frequent and heavy, not directly at the equator, but from 8° to 12° from it on either side. This means that both vertical convection and the earth's rotation are essential to their genesis; and since the trade winds blow from the north-east in the northern hemisphere and from the south-east in the southern hemisphere, it is the west side of an ocean which would have the largest amount of moisture and thus be the most likely place of origin of tropical cyclones. The doldrums never invade the South Atlantic, and one would thus expect this ocean to be free from tropical cyclones.

Since the earth's rotation is necessary for the formation of tropical cyclones, it follows that the largest number of cyclones should occur when the doldrums in their migration are farthest from the equator, *i.e.*, in August, September and October in the northern hemisphere, and in February, March and April in the southern hemisphere. In the Indian seas, however, these general conclusions are not borne out. Here the monsoon is the all-controlling wind; one would expect tropical cyclones to form in the Indian seas when the air is calm, warm and moist, *i.e.*, during the frequent calms which exist in the intermissions between the monsoon periods. Since there are two such transition periods in the year, there should be two periods of maximum frequency of cyclones, as is evident from Table 13 which gives the relative frequency of cyclones for each month in different parts of the earth, and from Table 14 giving the percentage frequency of severe cyclones for each month for the Bay of Bengal and the Arabian Sea.\*

Table 13.—Relative frequency of Cyclones.

	Jan.	Feb.	Mar.	Apr.	May	June	July	Aug.	Sept.	Oct.	Nov.	Dec.
1. Antilles ...	2	1	3	...	..	2	13	27	24	19	6	3
2. China Sea...	1	...	...	2	4	6	19	22	26	11	6	3
3. Bay of Bengal	2	...	1	8	18	9	3	3	5	27	16	8
4. Gulf of Oman	3	...	1	15	20	28	...	2	5	7	16	3
5. South Indian Ocean	24	25	18	12	4	...	...	...	...	1	5	10
6. South Pacific Ocean	29	19	28	5	1	...	..	...	...	1	4	12

\* Recently S. Basu of the India Meteorological Department has compiled a pamphlet entitled "Winds, Weather and Currents on the Coasts of India and the Laws of Storms" for the use of navigators.

† Taken from Angot, *Meteorologie*.

Table\* 14 — Percentage frequency of severe Cyclones.

	Jan.	Feb.	Mar.	Apr.	May	June	July	Aug.	Sept.	Oct.	Nov.	Dec.
1. Bay of Bengal	0	0	2	8	18	5	3	2	8	22	24	8
2. Arabian Sea	0	0	0	10	20	23	0	0	0	15	26	6

We have mentioned before that the distribution of wind and of temperature in depressions is not symmetrical. The same is equally true in the case of tropical cyclones. The isobars are often ellipses, the ratio of the major axis to the minor axis being sometimes even 2. The centre lies sometimes towards the front and sometimes towards the rear during the translatory motion of the cyclone. Generally the major axis is in the direction of motion of the centre, but may also make any angle with the direction of propagation. The determination of the path of the centre of a cyclone is thus attended with great difficulties.

If the distribution of temperature and of wind in a depression or cyclone were perfectly symmetrical, there would be no apparent reason for its displacement; the cyclone would remain stationary. The asymmetry actually observed in the depressions of temperate latitudes is the most important cause of their translatory motion. In tropical cyclones there does not seem to be much asymmetry in the distribution of temperature, so that the guiding factor is the unsymmetrical distribution of winds and precipitation.

Recently† S. C. Roy and A. K. Roy have studied the mechanism of the Indian cyclones of the transition period. Their investigations have led to the idealised structure of Indian cyclones represented in Fig. 49. In the beginning of the hot weather in India in April, a shallow current of the southwesterly winds of local origin sets in in the north of the Bay of Bengal. The winds become irregular in the southern parts of the Bay. But northerly or northwesterly winds of land origin still prevail over the Arabian Sea. By May the southwesterly winds of local origin dominate the whole of the Bay and set in also over the west of the Arabian Sea. During this transition period oceanic air of great depth occasionally penetrates into the south of the Indian seas. The overrunning of the local southwesterly winds by the oceanic winds or the encounter of the northwesterly land winds with the oceanic winds results in the formation of cyclones. The first of these two mechanisms appear to be more common in the latter half of the pre-monsoon period.

\* Taken from S. C. Roy and A. K. Roy's paper in *Beitr. z. Phys. d. freien Atm.*, Vol. 16, part 3, 1930.

† S. C. Roy and A. K. Roy, "Structure and Movement of Cyclones in the Indian Seas," *Beitr. z. Phys. d. freien Atm.*, Vol. 16, part 3 (1930).

At the beginning of the post-monsoon period the oceanic air gradually retreats to the south and the northeasterly winds set in in the north of the Indian seas. By November the northeasterly winds dominate almost the whole of the Indian seas. During this transition period the oceanic air is occasionally accelerated northwards giving rise to up-glide surfaces in which the oceanic air rises over the northeasterly land winds.

The oceanic air is composed of two more or less distinct currents, one from the south-west and the other from the south-east. An Indian cyclone of the transition period is thus formed by three air currents distinguished in Fig. 49 as land air from a northerly direction, south-east trades and south-west monsoon. The surface of separation between the south-east trades and the northeasterly land air constitutes an *active up-glide*\* surface over which a vigorous uplift of moist oceanic air with consequent heavy rain takes place. The surface of separation between the land air and the south-east monsoon forms another up-glide surface of a feeble character, where light precipitation occurs. The boundary between the south-west monsoon and the south-east trades is not always sharp, because these two air masses are not likely to differ appreciably in regard to humidity and temperature; but occasionally they develop a rain-belt along their meeting place. The intersection of the boundary surface with the earth's surface has been called the *deflection front*.

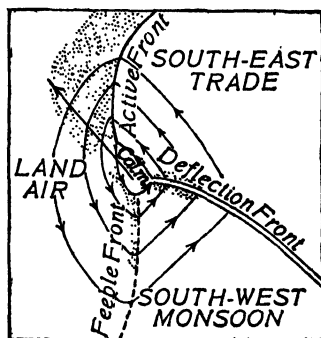

Fig. 49.—Structure of an idealised tropical cyclone.

The active up-glide surface constitutes the principal seat of energy of the cyclone and consequently the greatest destructive forces are associated with the passage of the active front. There is a close analogy between the active front of an Indian cyclone and the cold front of an extra-tropical cyclone.

There is another kind of depressions which enter India across the *northwestern frontiers* and sometimes pass over the whole of North India causing rainy weather along their tracks. They are most frequent during the period December—April.† These disturbances come from the west of India and are technically known as *western disturbances* or *depressions*; they have practically all the characteristics of the extra-tropical cyclone described above‡ and therefore we need not go here into details about them.

\* This term is the same as "cold front surface."

† See Lala Hem Raj, *Ind. Met. Mem.*, Vol. 21, Part VII (1913).

‡ See B. N. Banerji, *Meteorology of the Persian Gulf and Mekran*, published by the Ind. Met. Deptt.

**120. Energy of Cyclones and Depressions.**—Once a cyclonic whirl is started in the atmosphere the pressure at the centre of the whirl goes on decreasing. Thus the low pressure at the centre of a cyclone or depression is not the cause of the whirl motion, it is rather its after-effect. Now if the angle of inclination between the wind and the pressure gradient in a cyclone or depression were exactly  $90^\circ$  there would be no converging motion towards the centre, so that the velocity at the centre would be infinite. But in reality there is a convergence of the winds in a cyclone or depression and there is a central calm at the periphery of which the wind velocity is at its maximum. There must therefore be a strong updraft of air in the central part, otherwise the low pressure cannot be maintained. Now, the question is where does the energy necessary for the maintenance of a cyclone come from, or in other words, how is the updraft of air in the central parts kept up?

According to Ferrel's theory of cyclones the energy is supplied by the heat liberated due to the condensation of water vapour present in the ascending air. During its upward motion the temperature of the air is continuously maintained higher than that of its surroundings by the heat of condensation liberated due to precipitation, so that the updraft of air is maintained; and so long as the updraft is kept up, air must rush in from all sides in order to maintain the continuity. Thus the energy of the wind motion in a cyclone is derived from the heat of condensation of water vapour. Ferrel's theory is substantially correct in the case of the tropical cyclones in which the air is laden with moisture. In extra-tropical cyclones (or depressions), however, the air is found to be colder than its surroundings, and its moisture content is very little so that the maintenance of the depressions cannot be satisfactorily explained in the above way. In fact, Margules has, in his classic papers\* on the theory of storms, shown that the kinetic energy of air masses can be derived from the heat of condensation of water vapour only in special circumstances. There is no general theory which explains perfectly satisfactorily the origin and maintenance of depressions and cyclones.

**121. Thunderstorms.**—Besides the general atmospheric disturbances described above there are other disturbances of a more or less local nature which deserve mention, namely thunderstorms, tornadoes, whirlwinds, etc.

Thunderstorms occur in nearly every part of the world, but their frequency decreases rapidly from the equator towards the pole. Within the tropics there are many places where there are nearly 200 days with thunder-showers in the course of a year. Thunderstorms are less frequent over the oceans than over the land, and mountainous regions have far more than level country.

\* *Denkschr. Wien Akad. d. Wiss.*, Vol. 73 (1901); *Jahrb. d. K. Zentralanst. f. Met. und Geodyn.* Wien, 1903; *Met. Zeit.* (1906), p. 481.

A thunderstorm is too well known a phenomenon to need a careful definition. Its chief characteristics are an immense cumulo-nimbus cloud accompanied by copious precipitation, a marked drop in temperature and a more or less violent outrushing squall wind, which precedes the rainfall. It is always accompanied by thunder and lightning and sometimes by hail. It is a local storm covering a comparatively small area and often causing damage during its short duration.

Thunderstorms are most frequent in the afternoon although sometimes they occur also during the night. The phenomena before the occurrence of a thunder-shower are briefly as follows:—The day is hot, sultry and oppressive. The air is quiet, perhaps alarmingly quiet. The pressure gradually falls. Patches of cirrus, cirro-stratus or cirro-cumulus clouds are visible. The temperature rises very high and the absolute humidity is very high, but the relative humidity is somewhat low owing to the high temperature. In the early hours of the afternoon big cumulus clouds make their appearance on the horizon. The temperature drops a little as the sun is obscured by the clouds, but the oppressiveness continues. The thunderstorm comes nearer, and the huge cumulus clouds rise like domes and towers, one above the other. The clouds are in violent commotion. Soon the lightning flashes, the thunder rolls and big pattering raindrops or hailstones begin to fall. The calm transforms into a vigorous squall wind and the temperature drops rapidly. Soon the rain pours in torrents. After a time the wind weakens and the intensity of the rain diminishes. The sky begins to clear and the temperature rises somewhat. The storm has passed and is gradually disappearing.

The conditions required for a thunderstorm are: first, an adequate supply of moisture for cloud development; secondly, the existence of a process by which a vertical convection of the moist air can be effected. If the above conditions are fulfilled thunderstorms can occur at any hour of the day or night and in any season; but depending on the geographical situation the frequency of thunderstorms over a given region will vary with the seasons. In northeast India, for example, the frequency of thunderstorms is at its maximum in the premonsoon and postmonsoon periods. The second of the above two conditions can be realised in level countries by colder (and therefore heavier) air suddenly flowing in under the stratum of moist air, or by unusual heating of the land surface over which the moist air exists. The undercutting of warm moist



air by cold air is undoubtedly the mechanism of those thunderstorms which are generally associated with depressions. Accordingly in the temperate latitudes, where depressions are composed of two well-marked fronts, there are two types of thunderstorms, differing from each other mainly in their intensities, associated with the warm and the cold fronts. In mountainous regions thunderstorms may be brought about by the forced convection of warm moist air by the hill-slopes if the moist air current is of sufficient strength. The cold front storms develop along a belt and move end on, occasionally lasting for some hours at one place. In general thunderstorms drift with the wind at their level, but the variation of wind with height, and the development and dissolution of parts of the cloud mass, often make their movements complex. They occasionally travel at a high speed (up to 50 miles per hour).

It is found that raindrops are usually electrified. The charges may be positive or negative but positive ones predominate. Drops with charges of either sign may fall simultaneously. The charge per cubic centimetre of rain is generally less than one electrostatic unit ( $\frac{1}{3} \times 10^{-9}$  coulomb) but charges approaching 20 e.s. u. per cc. have been observed. The charges on snow are of the same order of magnitude.

The principal cause of electrification of rain is probably the breaking up of the drops.\* When the velocity with which a large drop is falling through the air exceeds a certain limit the drop is broken up into a number of small drops which become positively charged in the process. According to some investigators the corresponding negative charges are carried away by the finer spray, according to others by the air. The process will be accelerated where there are powerful upward currents of air to break up the drops. Similar effects will occur with snow. G. C. Simpson bases his theory of thunderstorms on these phenomena. In the parts of the active cumulo-nimbus clouds where the upward currents of air are most vigorous large drops are formed by the condensation of water vapour and by the amalgamation of small drops. In the strong currents the large drops are broken up and become positively electrified. The air with its negative charge passes on to other parts of the cloud. Large quantities of electricity, positive and negative, accumulate in different regions and the electric forces increase until a lightning flash occurs. The process is repeated as long as the storm lasts. Simpson's theory, therefore, explains satisfactorily the origin of electricity of summer thunderstorms, which occur in the lower levels of the atmosphere where large drops of rain can form. The electricity

\* "On the electricity of rain and its origin in thunderstorms," by G. C. Simpson, *London, Phil. Trans. R. Soc. A*, Vol. 209, pp. 379-413, 1909. This has been reprinted in *Indian Meteorological Memoirs*, Vol. 20, p. 141 (1910). See also Simpson, *Phys. Zeits.*, Vol. 14, p. 1057 (1913).

of winter thunderstorms and of summer thunderstorms in the cirrus region has been shown to be due to the breaking up of snow or ice particles.

Thunder is the noise which follows a flash of lightning attributed to the vibrations set up by the sudden heating and expansion of the air along the path of the lightning, followed by a rapid cooling and contraction. The distance of the lightning flash may be roughly estimated from the interval that elapses between seeing the flash and hearing the thunder, counting a mile for every five seconds.

The long continuance of the thunder is explained by the fact that the sounds from different parts of the lightning flash have different distances to travel to reach the observer. The changes in intensity are partly due to the crookedness of the flash but may also be caused by variations in the amount of energy developed along its course. The fact that what appears to the eye to be a single flash may really be half a dozen flashes, all occurring within a second or less and following the same path, complicates the question. The sound may echo back from mountain sides but whether echoes from the clouds add to the reverberation is doubtful.

The distance at which thunder can be heard is, as a rule, surprisingly small, being usually less than 10 miles, though distances ranging up to 40 miles and over have been reported in extreme cases.

Thunderstorms also occur in connection with V-shaped secondary depressions. Whenever an isobar, instead of being straight or uniformly curved, has the form of a pocket or trough, it is spoken of as V-shaped depression. If in the temperate latitudes a V-shaped depression crosses the country in summer, it is almost invariably attended with thunder-showers.

The mechanism of this type of thunderstorms, which are associated with depressions and so may be called front thunderstorms or line squalls, is practically the same as that of the cold wave since they are caused by the under-cutting of warm moist air by wedges of cold air. The theory of these phenomena need not therefore be repeated. It should, however, be mentioned here that the surface of separation between the cold and the warm samples of air during the advance of a cold front or of a line squall generally takes the form shown in the following diagram (Fig. 50) instead of being a more or less plain surface inclined to the horizon. W. Schmidt\* was the first to come to this conclusion from his laboratory experiments; this conclusion has since been verified in the actual atmosphere by G. Stüve.† The 'hump' which is called the "Squall head" (Boenkopf), at the tip of the wedge of cold air explains why these thunderstorms happen in the front of the advancing cold air. We shall not go into further details but we must just mention the interesting phenomenon of bifurcation of the advancing cold air mass, which was observed

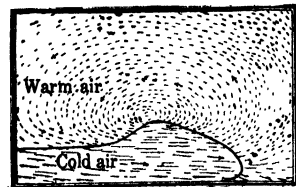

Fig. 50.—Mechanism of thunder-showers.

\* *Wien. Sitz. Ber.*, Vol. 119, Abt. IIa, 1910, p. 1101; *Met. Zeit.*, 1911, p. 35.

† *Wiss. Abh. d. preuss. aeronaut. Observat.*, Lindenberg, Vol. 14, 1922.

by Von Ficker\* during his investigation of the cold wave outbursts in North Asia and Russia. Exner† has given a theoretical explanation of this phenomenon of bifurcation.

There is also another type of thunder-rain, which is caused by what are known as "local heat thunderstorms." The mechanism of a local heat thunderstorm is as follows. In the morning the lower layers of the atmosphere nearest to the ground are heated up by the radiation from the ground, but the presence of an inversion layer formed during the night prevents any vertical convection of air. The result is that the air above the inversion is practically cut off from the terrestrial radiation; a labile equilibrium with high lapse-rate of temperature is thus established. In the afternoon when the temperature of the air of the lower levels has become highest, the inversion layer gives way and the potentially colder air from above comes down resulting in a violent uprush of the hot moist air with condensation of moisture and thunder and lightning. This type of thunderstorm occurs in limited regions as the name implies. It may be remarked here that the local heat thunderstorm is characterised by a steep vertical gradient of temperature in the higher levels and a quite stable stratification in the lower levels, from the ground up to about 1500 metres. In the case of the front-thunderstorm a steep vertical gradient of temperature in the higher levels need not precede the formation of the storm, although it would conduce to the severity of the storm if it did; but soon after the upward convection of the lower strata of moist air has started, a steep vertical gradient of temperature is established in the upper layers where the air is drier and therefore has a higher lapse-rate than the moist air down below.

**122. Tornadoes.**—The *tornado* is the smallest and yet the most violent and destructive of all storms. It is peculiar to the United States, but at times it occurs in a slightly modified form in other parts of the world. It is always associated with a violent thunder-shower with heavy thunder and lightning. The diameter of a tornado, which is a column of air in violent rotation about a more or less vertical axis, can be about 300 metres and the wind speeds in the central parts are of the order of 50 metres per second and in exceptional cases may be even 100 metres per second.

Since a tornado is almost always accompanied by a heavy thunder-shower, the characteristics of the day and the weather changes which precede the appearance of a tornado are the same which herald the coming of a violent thunder-shower. The distinctive thing about a tornado is the peculiar black funnel-shaped cloud which extends downward from the base of the heavy cumulo-nimbus cloud masses above. This cloud funnel sometimes descends down to the ground and rises again, executing thus a sort of oscillatory motion in an up and down direction.

The destruction wrought by a tornado appears to be caused both by excessive wind velocities and also by a sudden explosive action, which is probably due to the sudden decrease in the barometric pressure at the centre.

Tornadoes occur almost exclusively in the hottest months of the year and in the hottest part of the day. The cause of their origin is not known

\* *Met. Zeit.*, 1921, p. 85.

† *Wien. Sitz. Ber.*, Abt. IIa, Vol. 131 p. 366, 1922.

with certainty but it is very probable that sharp temperature contrasts in the horizontal as well as in vertical direction are responsible for the formation of these destructive whirls.

**123. Whirlwinds.**—There is another kind of atmospheric whirlwind, known as a dust-whirl which occurs in desert countries. The air in contact with the extremely hot sandy soil rises in a whirl carrying the dust and the sand with it thus assuming the appearance of a column of dust. If there is a general circulation superposed on it, the dust-whirl moves as a whole with the general current. The exact mechanism of the formation of the whirl is not known. The direction of rotation of the wind may be anti-clockwise as well as clockwise since owing to the small diameter of the whirl the centrifugal force is much greater than the deflective force due to the earth's rotation.

The relations between the horizontal and the vertical extents are very different in the case of different atmospheric disturbances. Below\* we give the ratio of the diameter to the height in the case of depressions, tropical cyclones, tornadoes and dust-whirls.

Depressions	Trop. Cyclones	Tornadoes	Dust-whirl
300	50	$\frac{1}{2}$	100

**124. Nor'westers of Bengal.**—During the transition months from March to June the plains of Bengal are visited by storms of land origin which often cause considerable damage. Occasionally these storms attain tornadic violence causing the loss of hundreds of lives. The phenomena preceding these storms, which occur mostly in the afternoons of hot oppressive days, are practically the same as those which herald the coming of a violent thunderstorm ; in fact they are a special type of thunderstorms peculiar to Bengal. The squalls come mostly from the north-west which accounts for the name *nor'westers* given to these highly destructive storms. They are popularly known in Bengal as *Kal-baishakhi*. The wind velocity during nor'wester squalls can rise to more than 100 miles per hour.

The mechanism of the nor'westers is not fully understood yet. Lately, however, S. N. Sen† has attempted to explain the nor'westers and showed that these violent thunderstorms are caused by wedges of cold air from the eastern Himalayas penetrating very often under the influence of western disturbances, into the warm moist air coming from the Bay of Bengal. According to him when the south-west monsoon is struggling to replace the north-east monsoon, the heavy cold air from the valleys flows down into the plains of Bengal in the form of wedges under the southwesterly Bay air causing a series of thunderstorms along the paths of the wedges. Sen has observed that the cold air from the north-east flows down the slopes of the ground like a stream of water with the result that the nor'westers are most frequent in certain regions, namely, along the river beds of Bengal, particularly along the Brahmaputra valleys.

\* Taken from Muller-Pouillet, *Lehrbuch der Physik*, Vol. V, Part I.

† *Nature*, No. 3195, Vol. 127 (1931).

## XII. WEATHER FORECASTING AND WEATHER SERVICE

**125. Weather Forecasting.**—A few concluding remarks about the principles of weather forecasting and about the organisation required for the prediction of weather may be of interest to the student. All weather phenomena are the results of the operation in the atmosphere of well-established physical laws, but the processes involved are on such a large scale, and the complications are so numerous that even at the present high state of development of meteorology as a science it is very difficult to find out causal relations between existing atmospheric conditions and the conditions which will prevail in future. In fact, it is doubtful if it will be ever possible to predict atmospheric phenomena from a study of the prevailing conditions with that degree of certainty with which it is possible to predict phenomena which are studied in what is commonly known as an exact science. In this sense meteorology can probably be said to be intermediate between the exact sciences, such as physics, and those descriptive sciences, for example botany, which do not attempt to find out general laws but whose aim is rather to describe individual phenomena.

Leaving aside the question of future developments one can easily realise that meteorological forecasts, if they are made correctly, would be of incalculable practical utility. The remarkable progress that has been accomplished in the last 25 years or so has strengthened the belief that it should be possible to forecast weather with reasonable accuracy with further development of both theoretical and observational meteorology. In the preceding sections of this chapter we have given a brief survey of the principles and laws of meteorology; it is the judicious application of these that constitutes the basis of weather prediction. No hard and fast rules for forecasting can therefore be laid down. Success in forecasting depends greatly on individual appreciation of the weather situation which again depends to a large extent on the

forecaster's capacity to utilise the knowledge of the transformations of atmospheric situations gathered by long experience. As the result of long experience meteorologists of different countries have evolved dependable methods of prediction which prove helpful in practice; but it should be understood, that the rules and methods of forecasting developed for a particular region of the earth need not necessarily be applicable to another region where geographical and climatological conditions may be very different. From this point of view the meteorology of a country has to be developed in the country itself although one can derive considerable benefit from the experience of others in other countries. It will be outside the scope of this short chapter to give a detailed and critical description of the different rules and methods of forecasting proposed in recent times: we shall restrict ourselves to indicating only the general principles of the commoner methods of weather prediction.

**126. Long-range and Short-range Forecasts.**—There are two types of forecasting, namely, long-range forecasting and short-range forecasting. The object of long-range forecasts is to predict the general characteristics of the weather during a long period of time, for example a year or a season. The aim of short-range forecasts, on the other hand, is to predict more or less in detail the weather during the next 24 or 48 hours. The weather services of western countries restrict themselves principally to the short-range forecasts. In eastern countries particularly in India, weather prediction has leaned more on the side of long-range forecasting, probably on account of the belief that the weather in the tropics, except for the occasional cyclonic storms which originate in the sea, is more or less uniform from day to day during any particular season. The result has been that in India at any rate the best part of the last 30 years has been devoted principally to developing methods of long-range forecasting\* (*e. g.*, monsoon forecasts) and while a considerable amount of work has

\* See papers by G. T. Walker in the Indian Meteorological Memoirs.

been done in this branch of meteorology much remains to be done in other directions, such as the origin of cyclones, the mechanism of thunderstorms, etc., which are by no means of minor importance in Indian meteorology. The problem of long-range forecasting has been attacked in different ways, such as finding weather correlations between regions of the earth widely separated from each other in the same or different seasons, or finding out periodicities in the variations of weather elements (from the data collected during a long period) by means of harmonic analysis. But the success achieved as yet in the methods of long-range forecasting hardly justifies any hope in the near future.

The short-range forecasts, on the contrary, are based almost entirely on the synoptic weather charts prepared daily from observations taken at stations forming a reasonably close network. The India Meteorological Department has at present provision for two charts (at 8 hrs. local time and 17 hrs. I. S. T). The meteorological departments of the larger European countries, such as Germany, France, Great Britain have each four synoptic charts per day, while the weather service of Norway prepares as many as six weather charts per day. The larger the number of synoptic charts and the larger the number of observation stations in the network, the greater is the opportunity of studying the details of the transformations of the weather situation and therefore the greater is the chance of success of the weather forecast. But it cannot be denied that even with several synoptic charts it is not yet possible to predict accurately in every detail the weather for the next twenty-four or forty-eight hours. The degree of success achieved in short-range forecasting is, however, already so large that practically every civilised country of the world finds it worthwhile to maintain one or more national weather services.

**127. Weather Service.**—The weather service is essentially similar in all countries. The meteorological network consists of a large number of observation stations of

different orders or grades. The India Meteorological Department has divided its stations into five orders. The first class observatories are provided with eye-reading as well as self-recording instruments. The second class observatories have generally only eye-reading instruments. Both the first and second class observatories telegraph regular observations twice daily to the different forecasting centres. The third class observatories have the same instrumental equipment as the second class ones, but observations are telegraphed to forecasting centres only once a day. The fourth class observatories are equipped with thermometers and raingauges only, but they are not required to telegraph observations daily to the forecasting centres. The fifth class observatories have only raingauges and they telegraph at 8 hours local time the amounts of rainfall during the past 24 hours whenever there is rain. The majority of Indian observatories are of the second or third class. In addition to the surface observatories there are a number of pilot balloon observatories which telegraph upper wind measurements to the forecasting centres.

The weather telegrams are sent in code by the reporting stations at the synoptic hours to the forecasting centres, where the messages are decoded and the observations are plotted on suitable maps of the area represented by the observation stations. The principal weather chart thus prepared represents the meteorological conditions prevailing at the surface level, all the barometer readings being reduced to the sea level and standard gravity. In addition to the barometer readings, generally cloud amounts, the wind forces and directions at the ground level, the dry-bulb temperatures and the amounts of precipitation are plotted on the principal surface chart. Apart from the barometric pressures and the winds which must be plotted on the principal surface chart for convenience of drawing isobars there is no definite practice followed about plotting the other elements which are often plotted on separate charts for the sake of clarity. Since the upper air conditions also materially influence the weather the winds at different levels



reported by the pilot balloon stations are also plotted on suitable maps and thus upper air charts showing the wind circulation at different levels above ground are prepared. The forecaster's appreciation of the weather situation will depend on the study of the various charts thus drawn up. In addition to the charts drawn up for the different meteorological elements it is the practice to prepare two other charts one giving the pressure changes in the last 24 or 12 hours and the other giving the variations from the normal values of the pressures. For economy of time and for avoiding unnecessary crowding of the weather charts different symbols are used for special weather phenomena such as thunderstorm, duststorm, hail, fog, haze, etc.

**128. Methods of Forecasting.**—Although success in forecasting depends to a great extent on the forecaster's personal experience of the weather changes that take place in a given region under different conditions, forecasters generally follow certain recognised methods of utilising the weather charts. The earlier meteorologists based their predictions on the positions and movements of "highs" and "lows" as represented by the surface isobars and their probable influence on the weather. The scientific principle underlying this method of forecasting becomes apparent when we remember the characteristic horizontal and vertical movements of air in the region of "highs" and "lows". The experiences gathered by the earlier meteorologists have sometimes been published as rules and maxims\* for weather predictions or in the form of weather catalogues,† which embody a wealth of useful knowledge.

Another method of prediction is based on the study of the pressure changes. This method was introduced by Eckholm, Brounow and Svrensky and during the Great War it was particularly developed in France. In former years some of

\* Bowie, E.H., "The Relation between Storm Movement and Pressure Distribution," *Monthly Weather Review*, Vol. 34, pp. 61—64 (1906).

† Gold, E., "Aids to Forecasting—Types of Pressure Distribution" Meteorological Office, London, Geoph-Memoir. No. 16, 1920.

the meteorological centres utilised the 24-hour or 12-hour pressure changes. In recent years these have been supplemented in European countries by the "barometric tendencies," *i.e.*, changes within the three hours preceding the observations. Thus in Europe where four synoptic observations per day are telegraphed, it is possible with the help of the barometric tendencies to construct eight charts in twenty-four hours approximately three hours apart. In France at the present time forecasting of weather is based principally on *isallobar charts*, *i.e.*, charts showing lines of equal pressure change within a chosen interval (3 h. 6 h. or 12 h. for example). At the "Office National Météorologique" of Paris, for example, isallobar charts are constructed with 12-hour changes and the forecaster tries to find out regions of marked rise or fall of pressure, which are called "nuclei of variations in 12 hours." From the movements of the nuclei of variations it is possible to estimate the progress of weather transformations.

Recently in Norway a new and very convenient method of forecasting has been developed on the basis of Bjerknes' theory of cyclones. This method, which is applicable to the greater part of Europe, has been further developed by German workers. It depends, as it will be evident from the structure of the cyclone given earlier in this chapter, on the identification of the fronts between the cold dry polar air and the warm moist equatorial air and on the estimation of the probable movements of these fronts. This method, by its very nature, is not applicable to regions of predominantly continental climate, but it can be applied with advantage to coastal regions even of tropical countries like India where it is possible to find a warm moist current of oceanic air and a distinctly colder drier current of continental or mountain air at least in certain seasons. This method of forecasting by the identification of the interacting air masses is practised with success at the Meteorological Office, Calcutta.

In addition to the issue of daily weather reports and forecasts for specified land areas, the forecasting centres of the India Meteorological Department have other duties in the

shape of warning against sea storms to ships in the Bay of Bengal and the Arabian Sea and against heavy rainfall for land areas. The Meteorological Office at Calcutta issues warnings also against local squalls to the rivercraft plying in the rivers of Bengal. An additional function of the forecasting centres of the Indian Meteorological Service is the issue of weather reports and forecasts to aviators.

*Books Recommended.*

1. Brunt, *Meteorology*.
2. Lempfert, *Meteorology*.
3. Humphreys, *Physics of the Air*.
4. Shaw, *Manual of Meteorology*.
5. Shaw, *Air and its Ways*.
6. Shaw, *Forecasting Weather*.
7. National Research Council, Washington. Physics of the Earth III, Meteorology.
8. Richardson, *Weather Prediction*.
9. Hann, *Lehrbuch der Meteorologie*.
10. Exner, *Dynamische Meteorologie*.
11. Wegener, *Thermodynamik der Atmosphäre*.
12. Defant, *Wettervorhersage*.
13. Angot, *Traité de Météorologie*.
14. Köppen, *Grundriss der Klimakunde*.
15. Bjerknes, *Dynamische Meteorologie und Hydrographie*.

## APPENDIX

### COMMON PHYSICAL CONSTANTS

Gas constant for a gram-molecule

$$\begin{aligned} &= 8.313 \times 10^7 \text{ ergs. degree}^{-1} \\ &= 1.986 \text{ cal. degree}^{-1} \end{aligned}$$

1 calorie (15°C)

$$\begin{aligned} &= 4.186 \times 10^7 \text{ ergs} \\ &= 4.184 \text{ int. joule} \end{aligned}$$

Absolute temperature of ice-point = 273.2°

Volume occupied by a perfect gas at N. T. P. =  $22.414 \times 10^3$  c.c.

Density of air at N.T.P. = 0.001293 gm. per c.c.

Specific heat of air at constant pressure = .2375

Density of mercury = 13.5955 gm. per c.c.

Gravity  $g$  at Allahabad = 978.98 dynes per gm.

Standard atmospheric pressure =  $1.0136 \times 10^6$  dynes per sq. cm.

Avogadro number for a gram-molecule =  $6.06 \times 10^{23}$

Mass of hydrogen atom =  $1.66 \times 10^{-24}$  gm.

Diameter of hydrogen molecule =  $2.47 \times 10^{-8}$  cm.  
(approximate)

Boltzmann's constant  $k$  =  $1.372 \times 10^{-16}$  erg. degree<sup>-1</sup>

Stefan's radiation constant  $\sigma$  =  $5.75 \times 10^{-12}$  int. watt cm.<sup>-2</sup>  
degree<sup>-4</sup>

Wien's constant  $b$  = 0.288 cm. degree.

Planck's constant  $h$  =  $6.55 \times 10^{-27}$  ergs.  $\times$  sec.

Gravitation constant  $G$  =  $6.6 \times 10^{-8}$  dyne cm.<sup>2</sup> gm.<sup>-2</sup>

Velocity of light in vacuum  $c$  =  $2.999 \times 10^{10}$  cm. sec.<sup>-1</sup>

Ratio of charge to mass ( $e/m$ ) =  $1.76 \times 10^8$  int. coul. gm.<sup>-1</sup>  
of an electron

Elementary charge  $e$  =  $4.774 \times 10^{-10}$  e. s. u.

Mass of the electron at rest =  $9.02 \times 10^{-28}$  gm.

Table 1.—Specification of the Beaufort Scale of Wind Force with Probable Equivalents of the Numbers of the Scale

Beaufort number.	Specification of Beaufort Scale on land, based on observations made at land stations.	Mean pressure* (at standard density) exerted on a disc		Equivalent speed in miles per hour	Limits of Speed			
		mb.	Lb. per sq. ft.		At 10 m. (33 ft.) in the open.	Miles per hour.	Metres per sec.	Feet per sec.
						Less than 1	Less than 0.3	Less than 2
0	Calm	0	0	0	Less than 1	Less than 0.3	Less than 2	
1	Light air	.005	.01	2	1-3	0.3-1.5	2-5	
2	Light breeze	.04	.08	5	4-7	1.6-3.3	6-11	
3	Gentle breeze.	.13	.28	10	8-12	3.4-5.4	12-18	
4	Moderate breeze.	.32	.67	15	13-18	5.5-7.9	19-27	
5	Fresh breeze	.62	1.31	21	19-24	8.0-10.7	28-36	

6	Strong breeze.	1.1	2.3	27	25-31	10.8-13.8	37-46
7	Moderate gale.	1.7	3.6	35	32-38	13.9-17.1	47-56
8	Fresh gale	2.6	5.4	42	39-46	17.2-20.7	57-68
9	Strong gale	3.7	7.7	50	47-54	20.8-24.4	69-80
10	Whole gale	5.0	10.5	59	55-63	24.5-28.4	81-93
11	Storm	6.7	14.0	68	64-75	28.5-33.5	94-110
12	Hurricane	Above 8.1	Above 17.0	Above 75	Above 75	Above 33.5	Above 110

\* This can be easily calculated from the well-known hydrodynamical law  $p = \frac{1}{2} \rho V^2$ . Thus for  $V = 2$  miles per

hour  $p = \frac{1}{2} \frac{0.01293}{10^3} \left( \frac{2 \times 1760 \times 36 \times 2.54}{60 \times 60} \right)^2 = .005$  mb

## WET AND DRY BULB HYGROMETER

The absolute humidity is given by the formula

$$p = p_{s,w} - \frac{1}{2}(t - t_w) \frac{b}{755}$$

where  $p$  is the absolute humidity in mms. of mercury,  $p_{s,w}$  the saturated vapour pressure at the temperature  $t_w$  of the wet bulb,  $t$  the temperature of the dry bulb and  $b$  is the barometric pressure.

From the above formula the following table is calculated. The factor  $\frac{b}{755}$  is taken to be unity. For  $p_{s,w}$  the values given in Table 3 have been employed.

Table 2 — Values of  $p$  in mm. of Hg. for different values of  $t$  and  $t - t_w$ .

Temp. $t$ ° C	0	1	2	3	4	5	6	7	8	9	10	11
0	4.6	3.7	2.9	2.1	1.3	0.5						
1	4.9	4.1	3.2	2.4	1.6	0.8						
2	5.3	4.4	3.6	2.7	1.9	1.1						
3	5.7	4.8	3.9	3.1	2.2	1.4	0.6					
4	6.1	5.2	4.3	3.4	2.6	1.7	0.9					
5	6.5	5.6	4.7	3.8	2.9	2.1	1.2	0.4				
6	7.0	6.0	5.1	4.2	3.3	2.4	1.6	0.7				
7	7.5	6.5	5.5	4.6	3.7	2.8	1.9	1.1				
8	8.0	7.0	6.0	5.0	4.1	3.2	2.3	1.4	0.6			
9	8.6	7.5	6.5	5.5	4.5	3.6	2.7	1.8	0.9			
10	9.2	8.1	7.0	6.0	5.0	4.0	3.1	2.2	1.3	0.4		
11	9.8	8.7	7.6	6.5	5.5	4.5	3.5	2.6	1.7	0.8		
12	10.5	9.3	8.2	7.1	6.0	5.0	4.0	3.0	2.1	1.2		
13	11.2	10.0	8.8	7.7	6.6	5.5	4.5	3.5	2.5	1.6	0.7	
14	12.0	10.7	9.5	8.3	7.2	6.1	5.0	4.0	3.0	2.0	1.1	
15	12.8	11.5	10.2	9.0	7.8	6.7	5.6	4.5	3.5	2.5	1.5	0.6
16	13.6	12.3	11.0	9.7	8.5	7.3	6.2	5.1	4.0	3.0	2.0	1.0
17	14.5	13.1	11.8	10.5	9.2	8.0	6.8	5.7	4.6	3.5	2.5	1.5
18	15.5	14.0	12.6	11.3	10.0	8.7	7.5	6.3	5.2	4.1	3.0	2.0
19	16.5	15.0	13.5	12.1	10.8	9.5	8.2	7.0	5.8	4.7	3.6	2.5
20	17.5	16.0	14.5	13.0	11.6	10.3	9.0	7.7	6.5	5.3	4.2	3.1
21	18.7	17.0	15.5	14.0	12.5	11.1	9.8	8.5	7.2	6.0	4.8	3.7
22	19.8	18.2	16.5	15.0	13.5	12.0	10.6	9.3	8.0	6.7	5.5	4.3
23	21.1	19.3	17.6	16.0	14.5	13.0	11.5	10.1	8.8	7.5	6.2	5.0
24	22.4	20.6	18.8	17.2	15.5	14.0	12.5	11.0	9.6	8.3	7.0	5.7
25	23.8	21.9	20.1	18.3	16.7	15.0	13.5	12.0	10.5	9.1	7.8	6.5
26	25.2	23.3	21.4	19.6	17.8	16.1	14.5	13.0	11.5	10.0	8.6	7.3
27	26.7	24.7	22.8	20.9	19.1	17.3	15.7	14.0	12.5	11.0	9.5	8.1
28	28.3	26.2	24.2	22.3	20.4	18.6	16.8	15.2	13.5	12.0	10.5	9.0
29	30.0	27.8	25.7	23.7	21.8	19.9	18.1	16.3	14.7	13.0	11.5	10.0
30	31.8	29.5	27.3	25.2	23.3	21.3	19.4	17.6	15.8	14.1	12.5	11.0

Table 3.—Maximum pressure of water vapour in millimetres of mercury at different temperatures

	0	1	2	3	4	5	6	7	8	9
0	4.579	4.926	5.294	5.685	6.101	6.543	7.013	7.513	8.045	8.609
10	9.209	9.844	10.52	11.23	11.99	12.79	13.63	14.53	15.48	16.48
20	17.54	18.65	19.83	21.07	22.38	23.76	25.21	26.74	28.35	30.04
30	31.82	33.70	35.66	37.73	39.90	42.18	44.56	47.07	49.69	52.44
40	55.32	58.34	61.50	64.80	68.26	71.88	75.65	79.60	83.71	88.02

	0	2	4	6	8	10	12	14	16	18
50	92.51	102.1	112.5	123.8	136.1	149.4	163.8	179.3	196.1	214.2
70	233.7	254.6	277.2	301.4	327.3	355.1	384.9	416.8	450.9	487.1
90	525.8	567.0	610.9	657.6	707.3	760.0	815.9	875.1	937.9	1004.4

Table 4.—Glaisher's tables for wet and dry bulb hygrometer

The depression of the dew-point is given by the relation

$$t - t_{dp} = f(t - t_w)$$

where  $t$  = temperature of the dry bulb,  $t_w$  that of the wet bulb and  $t_{dp}$  the dew-point,  $f$  is called the Glaisher factor and its values for different values of  $t$  are tabulated below:—

Dry bulb temperature (°C)	0	1	2	3	4	5	6	7	8	9
- 10°C	8.76	8.73	8.55	8.26	7.82	7.28	6.62	5.77	4.92	4.04
0	3.32	2.81	2.54	2.30	2.31	2.26	2.21	2.17	2.13	2.10
+ 10	2.06	2.02	1.99	1.95	1.92	1.89	1.87	1.85	1.83	1.81
20	1.79	1.77	1.75	1.74	1.72	1.70	1.69	1.68	1.67	1.66
30	1.65	1.64	1.63	1.62	1.61	1.60	1.59	1.58	1.57	1.56



## INDEX OF CHAPTER XII (METEOROLOGY)

- Abbot, 406**  
 Adiabatic expansion of humid air, 438  
 —, different stages of, 442-43  
 Adiabatic diagram, 439, 441  
 —equilibrium, 424  
 —lapse rate, 425  
 Air, motion of, *see* Motion of air  
 Airmeter, 376  
 Aitken's dust counter, 393  
 Alto-cumulus, 448  
 Alto-stratus, 448  
 Anemometers, 375 *et seq.*  
 —, Dines' pressure-tube, 376  
 —, pressure-plate, 375  
 —, Robinson's (rotation), 375  
 Angot, 362  
 Ångström, 407  
 Ångström's pyrheliometer, 406  
 Anticyclones, 481-82  
 —, pressure gradient and wind direction in, 464  
 —, weather and cloud distribution in, 482  
 —, wind distribution in, 464, 481  
 Anti-trades, 468  
 Assmann, 362, 367, 412  
 —psychrometer, 367  
 Atlas of clouds, international, 446  
 Atmosphere, 391 *et seq.*  
 —, composition of, 391 *et seq.*  
 —, at great heights, 396-98  
 —, at the earth's surface, 391-95  
 —, free electrons in, 395-96  
 —, minor constituents of, 393  
 —, particles in, 393  
 —, Atmosphere, dynamics of, 454 *et seq.*  
 —, equilibrium of, 435-38  
 —, general circulation of, 456 *et seq.*  
 —, heating and cooling of, 400 *et seq.*  
 —, height of homogeneous, 398  
 —, minor circulation of, 472  
 —, sources of energy of, 400  
 —, temperature distribution of, *see* Temperature, distribution of  
 —, thermodynamics of, 435 *et seq.*  
 Auto-convection gradient, 437  
  
**Balloons-sondes, 388**  
 Balloon ascents, 387  
 Balloon, pilot, 389  
 —, methods of investigation with, 390  
 Balloon sounding, 388  
 Bar, 372  
 Barograph, 372  
 Barometer, aneroid, 370-71  
 —, Fortin, 369  
 —, Kew pattern, 370  
 —, standard, 369  
 Barometric depression, 472, 482  
 —gradient, 458  
 —tendency, 499  
 Barrier theory, 480  
 Barye, 372  
 Beaufort, Admiral, 374  
 —scale, 371, 502-03  
 Bezold, 436  
 Bigelow, 475  
 Bjerknes, 362  
 Blandford, 362  
 Bort, Teisserenc de, 362  
 Bouguer, 466  
 Brandes, W. H., 361  
 Breezes, land and sea, 458  
 Buchan, 362  
 Buys-Ballot's law, 362, 463  
  
**Castelli Benedetto, 361**  
 Chemical hygrometer, 379  
 Circulation, anticyclonic, 464, 481  
 —between equator and tropical high pressure belt, 467  
 —between tropical high pressure and polar circle, 468  
 —cyclonic, 464, 472 *et seq.*  
 —general, of the atmosphere, 466 *et seq.*  
 —, polar front theory of, 480-81  
 —, three systems of, 467

- , minor, of the atmosphere, 472  
 — of the polar caps, 467  
 Cirro-cumulus, 447  
 Cirro-stratus, 447  
 Cirrus, 447  
 Clayton, 473, 474  
 Climate, 364  
 Climatological charts, 470, 471  
 Climatology, 359  
 Cloud burst, 452  
 Clouds, 382 *et seq.*  
 —, classification of, 446-49  
 —, formation of, 442, 446 *et seq.*  
 —, heights of, 382, 449  
 —, international classification of, 446-49  
 —, measurement of velocity and direction of, 383 *et seq.*  
 —, thickness of, 449  
 Cold front, 476  
 Condensation, forms of, 444  
 —, height of, 441-42  
 —, methods of causing, 433  
 Convective equilibrium, 424  
 Coriolis's force, 460  
 Cumulus, 448  
 Cumulo-Nimbus, 449  
 Cyclone, extratropical, 472 *et seq.*  
 —, barrier theory of, 479-80  
 —, characteristics of, 477  
 —, cloud in, 477  
 —, energy of, 488  
 —, evolution of, 477-78  
 —, family of, 478  
 —, general weather characteristics, 477  
 —, passage of, 473  
 —, path of centre, 473  
 —, pressure variations in, 473  
 —, pressure distribution in, 473  
 —, pressure gradient and wind direction, 464, 473  
 —, rain in, 477  
 —, temperature distribution in, 475-76  
 —, trajectories of air in, 475  
 —, wave theory of (Bjerknes), 478  
 —, weather distribution referred to centre, 473  
 —, wind motion in, 464, 474  
 Cyclones, tropical, 482 *et seq.*  
 —, central eye of, 483  
 —, characteristics of, 483-84  
 —, distribution of meteorological elements in, 483  
 —, energy of, 488  
 —, frequency of occurrence of, 485-86  
 —, origin of, 486-87  
 —, passage of, 483  
 Cyclones, tropical, regions of, 485  
 —, seasons of, 485  
 —, structure of, 487  
 Cyclostrophic wind, 463  
 Defant, 451  
 Defective force due to earth's rotation, 460  
 —, calculated values of, 465  
 Depression, *see* Cyclone  
 Dew, 378, 444  
 — point, 378  
 — — hygrometer, 380  
 Dines, 362  
 Dobson, 394  
 Doldrums, 466  
 Dove, 361  
 Dust particles, counting of, 393  
 —, number of, 393  
 Dynamical meteorology, 359  
 Easterly current, cause of, 466-67  
 Elements, meteorological, 363  
 Eliot, 362  
 Energy, radiant, 400 *et seq.*  
 Equilibrium of atmosphere, 435-38  
 —, indifferent, 435  
 —, labile, 436  
 —, stable, 436  
 Equivalent potential temperature, 444  
 — temperature, 443  
 Espy, 361  
 Exner, 362  
 Exposure, 377  
 Eye, central, of tropical cyclone, 483  
 Ferdinand II, 361  
 Ferrel, W., 362, 442, 467, 488  
 Field, J. H., 362  
 Fineman's reflecting nephoscope, 383  
 Fitz-Roy, Admiral, 362  
 Fog, 445

- , land, 445
- , radiation, 445
- Forecasting weather, 494 *et seq.*
- , information necessary for, 494-95
- , long-range, 495
- , methods of, 498-99
- , organization necessary for, 497
- , short-range, 496
- Franklin, 361
- Friction between earth and atmosphere, 465
- Frost, 444
- , hoar, 444
  
- Gale and storm warnings, 500
- Galileo, 360
- Geostrophic wind, 462
- velocity, 462
- Glaisher's factors, 505
- relation, 505
- Gold, E., 412, 432
- Gradient, barometric, 458
- , vertical temperature, 409, 425
- wind, 462
- Guericke, Otto von, 361
- Guldberg, 439, 465
  
- Hadley, 361, 467
- Hail, 453
- Hair hygrometer, 381
- ,hygrograph, 382
- Halley, 361
- Hann, 439
- Heat thunderstorms, local, 492
- Heaviside layer, 395
- Height of atmosphere, 398
- clouds, 382, 449
- , tropopause, 411
- Hertz, 439, 442
- Hertz's diagram, 441
- , modification of, by Neuhoff, 439, 441
- Hesselberg, 465
- Hildebrandsson, 362, 467, 474
- History of meteorology, 360-63
- Homogeneous atmosphere, 398
- Horse latitudes, 468
- Humidity, absolute, 378
- , relative, 378
- , annual and diurnal variation of, 432
- measurement of, 379 *et seq.*
  
- variation with latitude and altitude, 433
- Humphreys, 397, 412
- Hurricane, 483
- Hydrograph, 382
- Hygrometers, 379 *et seq.*
- , chemical, 379
- , dew-point, 380
- , hair, 381
- , Regnault's, 381
- , wet and dry bulb, 379
- Hygrometry, 379 *et seq.*
  
- Insolation, 400 *et seq.*
- , absorption of, by the atmosphere, 404-405
- , duration of, 401-402
- , variation in amount received according to latitude and time, 402-404
- International cloud atlas, 446
- Inversions of temperature, 414
- Ions, 395
- Isallobars, 499
- Isobaric charts, 427-29
- , annual, 428
- of January, 429
- of July, 429
- Isobars, 428
- Isothermal charts, annual, 417
- of January, 416
- of July, 417
- Isothermal layer, 411
- Isotherms, 416
  
- Kennelly, 395
- Kites, investigation by means of, 387-88
- Knoche, 413
- Köppen, 436
- Krakatoa, eruption of, 393
  
- Land-breeze, 458
- Langley, 406
- Laplace's law of barometric distribution, 422
- Lapse-rate, adiabatic, 409, 425
- , variation of, with height over Agra in different seasons, 410
- Layer, isothermal, 411
- Lenard, 452
- Le Verrier, 362

- Ley, 449, 474  
 Loomis, 361
- Mackerel sky**, 447  
**Margules**, 362, 488  
**Meteorographs**, ballons-sondes, 388  
 —Dines ballons-sondes, 389  
 —, kite, 387-88  
**Meteorological elements**, 363  
 —, measurement of, 364 *et seq.*  
 —, in upper air, 387 *et seq.*  
 — instruments, 364 *et seq.*  
 — observatories in India, 363  
 —, five types of, 497  
 — optics, 359  
**Mohn**, 439 465  
**Monsoons**, 470-72  
**Motion of air**, frictionless horizontal, 461  
 —, steady rectilinear, 462  
 —, steady horizontal, due to curved isobars, 463
- Nephoscope**, Fineman's reflecting, 383  
 —, direct-vision, 385  
**Neuhoff**, 439, 441  
**Nimbus**, 448  
**Normand**, C. W. B., 362  
**Nor'westers** in Bengal, 493  
**Nuclei for condensation**, 445
- Ozone in atmosphere**, 394-95
- Peppler**, 449  
**Piddington**, 361  
**Pilot balloons**, 389  
 —, methods of observation of, 390  
**Polar front**, 477  
 — theory, 479  
**Potential temperature**, 436  
**Precipitation**, 450  
**Pressure**, distribution of, 421 *et seq.*  
 — distribution over the globe, 428-29  
 — vertical, in stratosphere, 423  
 — in troposphere, 421, 425  
 — hypothesis of diurnal variation of, 427  
 —, measurement of, 369 *et seq.*  
 —, reduction to sea-level, 422  
 — units, 372  
 — variations, annual, 427
- , diurnal, on earth's surface, 426  
 —, variation with latitude, 426  
**Prevailing westerlies**, 464-68  
**Psychrometer**, Assmann, 367  
 —, wet and dry bulb, 379  
**Pyranometer**, 408  
**Pyrheliometer**, 405  
 —, Ångström's, 406
- Radiation**, effective, 407  
 —, solar, *see* Solar radiation  
 —, terrestrial, 407  
**Rain**, measurement of, 386 *et seq.*  
**Raindrops**, electrification of, 490  
 —, size and maximum velocity of fall, 451  
**Rainfall**, early records of, 386  
 — in thunderstorms, 490  
 —, measurement of, 386 *et seq.*  
 —, production of, 452-54  
**Rain-gauge**, 386 *et seq.*  
 —, float, 387  
 — Korean, 360, 386  
 —, recording, 386-87  
 —, Symon's, 386  
 —, tipping-bucket, 386  
**Ramsay**, Sir William, 391  
**Redfield**, 361  
**Regnault's dew-point hygrometer**, 381  
**Rotation of the earth**, 459  
 —, effect of, 460
- Schmidt**, 444, 451  
**Sea-breeze**, 458  
**Shaw**, Sir Napier, 362, 443  
**Simpson**, 432  
**Simpson's theory**, 490  
**Snow**, 452  
 — crystals, 453  
**Solar constant**, 406  
 —, variation of, 407  
**Solar radiation**, 400 *et seq.*  
 —, directness of, 401  
 —, duration of, 401  
 "Spider," 389  
**Sprung**, 457  
**Squall-line**, 476  
**Stevenson screen**, 365  
**Stratosphere**, 411  
 —, physical explanation of, 411-14  
**Sun**, distance of the, 401

- ,presentation of earth to, 402
- Sunshine recorder, 385
- ,Campbell-Stokes', 385
- ,Jordan photographic, 385
- Surface of discontinuity, 480
- Synoptic charts, 496
  
- Teisserenc de Bort, 411
- Temperature of air, 364
  - ,annual variation of, at different latitudes, 415
  - ,distribution of, 408 *et seq.*
  - ,over the globe, 414
  - ,vertical, 408-10, 425
  - ,vertical gradient, 409, 425
  - ,limiting value of, 437
  - ,diurnal variation of, 419
  - ,effect of altitude on, 420
  - ,effect of latitude and season on, 420
  - ,equivalent, 443
  - ,potential, 444
  - ,extremes of, 419
  - ,mean, 419
  - ,potential, 436
  - ,real, 365
  - ,reduction to sea-level,
- Tephigram, 443
- Theodolite, 390
- Thermal equator, 418
- Thermographs, 367
- Thermometer, other kinds of, 368
  - ,sling, 366
  - ,ventilated (psychrometer), 367
- Thermometer shelter method, 365
- Thunder, 491
- Thunderstorms, 488
  - ,characteristics of, 489
  - ,conditions for occurrence, 489
  - ,local heat, 492
  - ,mechanism of, 491
  - ,rainfall in, 490
- Tornadoes, 492
- Torricelli, 361
- Trade winds, 466
  - ,cause of, 466
- Trajectories of air, 475
- Tropopause, 411
- Troposphere, 411
- Typhoons, 483
  
- Upper air, humidity of, 431-32
  - ,investigation of, 387 *et seq.*
  - ,temperature gradient of, 435
  - ,wind variations in, 456
- Utility of meteorology, 494
  
- Vane, wind, 373
- V-shaped depression, 491
  
- Walker, 362
- Warm front, 476
- Water vapour in the atmosphere, 430 *et seq.*
  - ,in lower atmosphere, 430-31
  - ,in stratosphere, 432
- Weather forecasting, 494 *et seq.*
- Weather maps, 496-97
  - report, typical, 363
  - service, 496-98
- Westerlies, 467-68
- Western disturbances, 479
- Wet and dry bulb hygrometer, 379
- Whirlwinds, 493
- Wilson, 361
- Wind, annual variation of, 456
  - ,Buys-Ballot's law, 362, 463
  - ,cause of, 457-58
  - ,cyclotrophic, 463
  - ,definition of, 372
  - ,diurnal variation of, 455
  - ,general circulation of, 466 *et seq.*
  - ,geostrophic, 462
  - ,gradient, 462
  - ,influence of earth's rotation on, 459-61
  - ,measurement of, 372 *et seq.*
  - ,relation between wind velocity and pressure gradient, 462, 464
  - Rose, 454
  - systems, typical, 467 *et seq.*
  - ,modification of, 469 *et seq.*
  - vane, 373
  - estimation of, 374
  - velocity, mean, 454
- Winds, cause of prevailing westerly, 468.

