

**ALBERT R. MANN
LIBRARY
AT
CORNELL UNIVERSITY**

Cornell University Library

QC 861.G4

Meteorology; an introductory treatise, by



3 1924 002 956 518

mann

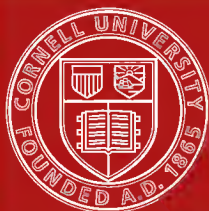

Cornell University Library

The original of this book is in
the Cornell University Library.

There are no known copyright restrictions in
the United States on the use of the text.

METEOROLOGY



AURORA BOREALIS, showing streamer curtain

METEOROLOGY

An Introductory Treatise

BY

A. E. M. GEDDES

O.B.E., M.A., D.Sc.

Lecturer in Natural Philosophy in the University of Aberdeen

BLACKIE AND SON LIMITED

50 OLD BAILEY LONDON
GLASGOW AND BOMBAY

1921

@
QC 861
G4

@28667

PREFACE

There are many classes of the community to whom the weather conditions are of the utmost importance. The aviator, the farmer, the sailor, and even the holiday-maker are all interested in the state of the weather, though in very different ways. The study of the weather from one man's point of view is therefore a very different thing to a study of it from another's point of view. But though the subject may be developed along different lines by different sections of the community, yet the principles underlying it are in all cases the same.

The present book has been written with the view of indicating these principles, putting them in their simplest form, and avoiding, as far as possible, the use of mathematical language. In this way the student who has only an elementary training in mathematics will be able to follow the reasoning.

Also, as the book is intended to serve as an elementary text-book, I have endeavoured to avoid developing any one part at the expense of another. Any chapter might quite easily be expanded into a book in itself, but in so doing the object for which the book is written would be lost sight of.

Meteorology, like many other sciences, is developing very rapidly at the present day, and in a book of this type it is impossible to embody all the latest developments. The discovery of the conditions within the upper atmosphere or stratosphere has influenced the development of modern meteorology to a very great extent. Throughout the book, therefore, the stratosphere and its influence have been kept before the reader.

PLAN OF THE BOOK

The book may be very conveniently divided into three main sections, together with the final chapter wherein application has

been made of the conclusions arrived at in the preceding chapters. Section one, consisting of three chapters, forms the introductory part. Herein are found a short historical sketch of the subject, and methods of attacking and solving certain meteorological problems. Likewise the atmosphere, that gaseous envelope in which all meteorological phenomena take place, is dealt with briefly, while a short chapter is devoted to the study of solar radiation.

The next five chapters constitute section two, and deal with the subject-matter of meteorology itself. In treating of temperature I have employed the gas scale throughout, indicating at the same time the relation between it and the other scales. By this means all negative values are got rid of. Also all problems involving the alteration of temperature through the expansion or the compression of a gas must be treated on this scale, and therefore the plan of recording all temperatures on the absolute or gas scale gets rid of the necessity of conversion. Further, this scale is the only scale on which there is a definitely fixed temperature, namely, the absolute zero of temperature.

Pressure is a force, and therefore should be expressed in units of force. The dyne, the absolute unit of force in the C.G.S. system, is, however, extremely small, and consequently in meteorology the unit employed is 1000 dynes or a "millibar". The Standard Atmosphere is 1,000,000 dynes per square centimetre or 1000 millibars, and is called a "bar". Until comparatively recently, however, all pressures were expressed in terms of the length of a column of mercury. But during the last few years the Daily Weather Reports issued by the Meteorological Office, London, have shown the pressures expressed in millibars. Therefore it is essential that everyone who wishes to make use of these reports should understand what a millibar (mb.) is. Hence throughout the book all pressure-values have been expressed in millibars.

Chapter VIII has been devoted to a study of the upper atmosphere. This chapter might with advantage be read before the section in Chapter VII which treats of the origin of cyclones of mean latitudes. Much of the material in this chapter I owe to the writings of Mr. W. H. Dines, F.R.S., and Captain C. J. P. Cave, to both of whom I wish to express my indebtedness.

The third section is devoted to a short study of the electrical, optical, and acoustical phenomena occurring in the atmosphere.

These phenomena, though not pertaining directly to meteorology, yet are closely allied to the subject. They are often of great assistance in indicating the temperature distribution in the atmosphere, and thereby help greatly in the matter of weather forecasting.

In the last chapter I have endeavoured to show how, by using the conclusions arrived at in the preceding chapters, one may develop a reasonable method of weather forecasting. Also I have attempted to indicate how any individual with the aid of a barometer, a barograph, a wind-vane, and thermometers may, by careful observation, forecast over short periods and for limited areas with considerable accuracy.

A brief survey of the factors that determine climate is to be found in the concluding sections. The various climatic divisions of the globe are considered, while the climate of the British Isles is dealt with a little more in detail.

ACKNOWLEDGMENTS

Figs. 14, 19, 30, 60, 60a, 74, 80, 81, 82, have been reproduced by the permission of the Controller of H.M. Stationery Office from publications of the Meteorological Office.

I have to thank the Meteorological Committee for the loan of blocks for figs. 61, 62, 72, 73, 75, 76, and 78.

For the coloured drawings, the cloud photographs, with the exception of those taken above the clouds, for many of the photographs of instruments, and also for the line drawings of many of the figures including those representing the barometers and anemometers, I am indebted to Mr. G. A. Clarke, F.R.P.S., of the Aberdeen Observatory. I owe the photographs reproduced on Plate VIII to Captain Cave and to Captain C. M. K. Douglas, R.A.F., respectively. The photographs of lightning flashes reproduced on Plate XVII (*a* and *b*) are due to H. H. Cowan, Esq., London, while I am indebted to my publishers for the blocks for figs. 27, 54, 67, 68, and for Plates IX and XVII (*c*). Wherever figures have been adapted from other publications acknowledgment has been made either in the text or on the figure.

I desire to express my thanks to Sir Napier Shaw, F.R.S., late Director of the Meteorological Office, for permission to photograph or make drawings from the various instruments in the Aberdeen

Observatory, and to Professor C. Niven, F.R.S., for like permission with regard to instruments belonging to the Natural Philosophy Department of the Aberdeen University. I am also indebted to Professor Niven for the interest he showed during the preparation of the text and for many useful hints given at that time.

Not only do I owe many of the photographs and drawings reproduced in the book to Mr. G. A. Clarke of King's College Observatory, but I obtained much valuable information from his almost unique experience in the observation of many meteorological phenomena.

Captain Cave I have to thank for reading the proof-sheets, and for adding many helpful suggestions while the book was passing through the press.

I take the present opportunity of thanking the publishers for the great care they have taken in the production of the work.

ABERDEEN, 1920.

A. E. M. GEDDES.

CONTENTS

CHAPTER I.—INTRODUCTION

	Page
A. HISTORICAL - - -	1
B. UTILITY - - -	12
C. METEOROLOGICAL ELEMENTS - - -	16
D. METHODS OF INVESTIGATION - - -	18
(a) Mean Values.	
(b) Application of Statistical Methods.	

CHAPTER II.—THE ATMOSPHERE

ITS PHYSICAL PROPERTIES—ITS COMPOSITION—DISTRIBUTION OF ITS COMPONENT GASES—ITS HEIGHT - - -	27
---	----

CHAPTER III.—RADIATION

SOLAR RADIATION OR INSOLATION—INSOLATION REACHING THE EARTH —VARIATION WITH LATITUDE AND SEASON—TRANSPARENCY OF THE ATMOSPHERE—ACTINOMETRY—THE SOLAR CONSTANT	38
---	----

CHAPTER IV.—TEMPERATURE

A. DETERMINATION OF TEMPERATURE - - -	54
(a) Thermometers and Thermometry.	
(b) Methods of Observation.	
RESULTS OF OBSERVATION - - -	66
(a) Variations of Temperature: (1) Diurnal, Effect of Altitude; (2) Annual, Effect of Latitude.	
(b) Temperature Gradient, Vertical.	
(c) Reduction to Sea-level.	
(d) Isothermal Charts.	
B. LAND AND WATER TEMPERATURES - - -	87
(a) Ground Temperatures, Diurnal and Annual Oscillations.	
(b) Sea Temperatures: at the Surface, Effect of Ocean Currents; at the Bottom.	
(c) Spring Temperatures.	
(d) Lake Temperatures.	
(e) River Temperatures.	

CHAPTER V.—PRESSURE AND THE GENERAL CIRCULATION OF THE ATMOSPHERE		Page
A. PRESSURE: ITS OBSERVATION AND DISTRIBUTION		95
(a) Barometers and Barographs		
(b) Pressure Units.		
(c) Variations of Pressure: (1) Diurnal, (2) Annual; Effect of Latitude.		
(d) Reduction to Sea-level.		
(e) Isobaric Charts.		
B. WIND: ITS OBSERVATION AND DISTRIBUTION	- - -	117
(a) Direction and Velocity.		
(b) Anemometers and Anemographs.		
(c) Variations in Direction, Diurnal; Effect of Altitude.		
C. THE GENERAL CIRCULATION OF THE ATMOSPHERE		128
(a) Water Analogy.		
(b) Horizontal Pressure Gradient and the Effect of the Earth's Rotation.		
(c) Cyclonic and Anticyclonic Motion.		
(d) The General Circulation.		
(e) Wind Systems: Trade Winds and Anti-trades; Monsoons; Land and Sea Breezes; Mountain and Valley Winds.		
CHAPTER VI.—WATER VAPOUR IN THE ATMOSPHERE		
A. EVAPORATION AND HUMIDITY	- - -	146
(a) Sources of Water Vapour.		
(b) Humidity, Absolute and Relative.		
(c) Hygrometry and Hygrometers.		
(d) Variations in Absolute Humidity: (1) Diurnal; (2) Annual.		
(e) Variations in Relative Humidity: (1) Diurnal; (2) Annual.		
B. CONDENSATION		157
(a) Methods of Causing Condensation.		
(b) Clouds, their Classification; International Definitions and Descriptions; Height; Formation; Amount.		
(c) Fog: Smoke, Sea, and Land Fogs; Drifting and Radiation Fogs.		
(d) Dew; Hoar Frost; Rime; Glazed Frost.		
C. PRECIPITATION		183
(a) Rain and Raindrops; Types; Distribution in a Storm; Measurement of Rainfall; Rain-gauge.		
(b) Variations in Rainfall: (1) Diurnal; (2) Annual.		
(c) Isohyets, Distribution over (1) Land Areas, (2) Oceans.		
(d) Snow: Snow Crystals and Snowflakes.		
(e) Water Equivalent of Snowfall.		
(f) Snowfall Distribution; Perpetual Snow.		
(g) Hail: Types; Life History; Distribution.		

CHAPTER VII.—THE MINOR CIRCULATIONS OF THE ATMOSPHERE

	Page
A BAROMETRIC DEPRESSION	199
A. EXTRATROPICAL CYCLONES OR DEPRESSIONS AND ANTICYCLONES	201
(a) Cyclones: Characteristics; Intensity; Wind Distribution; Winds, Geostrophic, Cyclotrophic; Gradient; Weather Distribution; Air Trajectories; Paths of Depressions; Isallobars; Velocity of Translation of the Centre.	
(b) Anticyclones: Characteristics; Intensity; Wind and Weather Distributions; Direction of Motion; Velocity of Translation.	
(c) Winds Associated with Cyclones and Anticyclones.	
(d) Origin of Cyclones and Anticyclones of Mean Latitudes; Different Theories; Energy in a Depression.	
B. TROPICAL CYCLONES	232
Regions of Occurrence; Characteristics; Distribution of the Meteorological Elements round the Centre; the Central Eye; Trajectories; Frequency; Origin.	
C. TORNADOES, WHIRLWINDS, WATERSPOUTS	241
(a) Tornadoes: Characteristics; Frequency; Probable Cause; Effects.	
(b) Whirlwinds and Waterspouts.	
D. LINE SQUALLS	244
Cause; Characteristics; Air Motion in a Squall.	
E. THUNDERSTORMS	249
Cause; Types; Distribution; Rainfall in a Thunderstorm; Hail.	

CHAPTER VIII.—THE FREE ATMOSPHERE

EARLY INVESTIGATIONS; KITES; BALLONS-SONDES; PILOT BALLOONS	256
A. INSTRUMENTS FOR (1) KITES, (2) BALLONS-SONDES; TESTING OF INSTRUMENTS	259
B. RESULTS OF OBSERVATION; QUANTITY; RELIABILITY; METHOD OF WORKING UP A RECORD	264
(a) Mean Values; Temperature and Temperature Gradients, Diurnal and Annual Variations of; the Tropopause; Pressure and Pressure Gradients; Pressure and Temperature in Cyclones and Anticyclones.	
(b) Wind Velocity in the Free Atmosphere; Methods of Observation and Calculation; Results.	
(c) Distribution of Pressure and Temperature in the Free Atmosphere as revealed by Pilot Balloons.	

CHAPTER IX.—ATMOSPHERIC ELECTRICITY

	Page
EARLY INVESTIGATIONS; DEFINITIONS	- 293
(a) Electrical Potential of the Atmosphere; Measurement; Variations, (1) Diurnal, (2) Annual; Effect of the Meteorological Elements.	
(b) Charge per Unit Volume of the Atmosphere.	
(c) Electrical Conductivity of the Atmosphere; Coulomb's Law; Dissipation Coefficient; Ions; Variations, (1) Diurnal, (2) Annual; Effect of the Meteorological Elements.	
(d) Ions; Charge; Number per Cubic Centimetre; Velocity.	
(e) Electric Current in the Atmosphere, Measurement of; Value.	
(f) Electricity of the Clouds; Charge on Raindrops, on Snow; Origin of Electricity on Raindrops; Visible Electrical Discharges, St. Elmo's Fire, Lightning; Thunder.	
(g) Origin of Atmospheric Electricity; Various Theories.	
(h) The Aurora.	

CHAPTER X.—ATMOSPHERIC OPTICS

(a) PHENOMENA DUE TO THE GASES OF THE ATMOSPHERE ALONE	- 321
Refraction; Mirage; Looming; Fata Morgana; Scintillation.	
(b) PHENOMENA DUE TO PARTICLES OCCASIONALLY PRESENT IN THE ATMOSPHERE	- 326
(i) Phenomena due to Refraction and Reflection—Halos.	
(ii) Phenomena due to Diffraction—Coronae.	
(iii) Phenomena due to Diffraction in Conjunction with Refraction and Reflection—Rainbows.	
(c) PHENOMENA DUE TO PARTICLES ALWAYS PRESENT IN THE ATMOSPHERE	339
The Blue Colour of the Sky; Sunrise and Sunset Colours; Phenomena accompanying Twilight; Duration of Twilight; First and Second Purple Lights.	

CHAPTER XI.—ATMOSPHERIC ACOUSTICS

SOUND	- 344
Propagation and Velocity in a Uniform Medium; Reflection and Refraction of Sound Waves; Thunder; Sound-ranging; Audibility of Distant Gunfire.	

CHAPTER XII.—WEATHER FORECASTING AND CLIMATE

A. WEATHER FORECASTING	Page 352
Information Necessary; Organization; Synoptic Charts, their Composition and Use in Forecasting; Guilbert's Rules; General Forecast for any District; Gale Warnings; Types of Weather; Persistency of a Type; Forecasting from (1) Local Information, (2) Local Information com- bined with the General Forecast for the District.	
B. CLIMATE	377
Weather and Climate; Factors which Determine Climate; Subdivisions of the Globe; Various Subdivisions; the Climate of the British Isles; Factors Determining it; Distribution of Temperature, Rainfall, Cloud Amount; Extreme Values.	
INDEX	385

LIST OF ILLUSTRATIONS

PLATE	PLATES	Page
	Aurora Borealis, showing Streamer Curtain	<i>Frontispiece</i>
I.	Barograph, M.O. Pattern Hair Hygrograph, M.O. Pattern.	- 100
II.	(a) Cirrus, True Type, showing Thread Structure - - (b) Cirro-stratus, in Dense Sheets.	164
III.	(a) Cirro-cumulus, Globular and Waved Forms (b) Alto-stratus, Uniform Sheet with Degraded Cumulus below.	164
IV.	(a) Alto-cumulus, in Parallel Bands - (b) Strato-cumulus, Heavy Masses.	166
V.	(a) Nimbus, a Passing Shower with a Rainbow (b) Cumulus, Detached Typical Form.	166
VI.	(a) Cumulo-nimbus, Anvil-topped Form associated with Thunderstorms (b) Cumulo-nimbus, Massive Hail and Shower Clouds.	168
VII.	(a) False Cirrus, above Small Cumulo-nimbus Cloud Group (b) Alto-cumulus, massed into Lenticular Banks.	168
VIII.	(a) Strato-cumulus, Upper Surface as seen from an Aeroplane (b) Cumulo-nimbus, the Summit of a Thundercloud.	170
IX.	Mist in the Woods: the Condensation of Water Vapour in the Air - - - -	180
X.	(a) A Waterspout - (b) A "Line Squall" Front.	244
XI.	Ballons-sondes Apparatus: Meteorograph Record, General View. The "Spider".	262
XII.	Diagrammatic Representation of the Vertical Distribution of Air Temperature -	270
XIII.	Theodolite and Pilot Balloon - -	280
XIV.	Flame Collector - - Two Electroscopes: (a) Simple Gold Leaf Electroscope. (b) Exner Electroscope with Dissipation Cylinder.	294

PLATE	Page
XV. Dolezalek Electrometer - - - - -	296
XVI. Ebert's Aspiration Apparatus with Zamboni Pile - - -	306
XVII. (a) Lightning Flash from Cloud to Cloud - - -	314
(b) Twin Flashes of Lightning.	
(c) Lightning Flashes in a Tropical Thunderstorm.	
XVIII. Effect of Lightning on Window Pane - - -	316
XIX. (a) Solar Halo with Arc of Contact and a Parhelion - - -	326
(b) Lunar Corona.	
XX. (a) Zodiacal Light - - - - -	342
(b) Purple Light.	

DIAGRAMS

FIG.	Page
1. Temperature Variation at Aberdeen, 3rd August, 1919 -	16
2. Temperature Variation at Aberdeen, 1st August, 1919 - -	17
3. Mean Values - - - - -	18
4. Distribution of the Gases in the Atmosphere (after Humphreys)	31
5. Cause of Twilight - - - - -	37
6. Showing Distribution of Radiation - - - - -	40
7. Radiation: Annual Variation in Different Latitudes -	42
8. Radiation: Variation with Latitude and Season -	44
9. Radiation: Variation with Latitude - - -	47
10. Solar Radiation at Mont Ventoux - - - - -	51
11. Solar Radiation at Montpellier - - - - -	51
12. Black Bulb in Vacuo - - - - -	52
13. Assmann Ventilation Thermometer - - - - -	59
14. The Stevenson Screen - - - - -	60
15. Ordinary Thermometer - - - - -	61
16. Details of Maximum and Minimum Thermometers -	62
17. Six's Maximum-Minimum Thermometer - - -	63
18. The Telethermometer - - - - -	64
19. The Thermograph, M.O. Pattern - - - - -	65
20. Diurnal Variation of Temperature for January and July (Aberdeen and Kew) - - - - -	68
21. Diurnal Variation of Temperature: Effect of Altitude (Parc St. Maur and Eiffel Tower) - - - - -	72
22. Annual Variation of Temperature (Aberdeen and Kew) -	73
23. Annual Variation of Temperature: Effect of Latitude	74
24. Isanomalous Curves for January - - - - -	85
25. Isanomalous Curves for July - - - - -	86
26. Temperature of the Ground: Magnitude of the Oscillations; Lag of Maximum - - - - -	88
27. The Simple Barometer - - - - -	96
28. The Fortin Barometer - - - - -	97
29. The Kew Barometer - - - - -	98

LIST OF ILLUSTRATIONS

xvii

FIG.	Page
30. The Barograph, M.O. Pattern	100
31. Diurnal Variation of Pressure for January and July (Aberdeen and Kew)	102
32. Annual Variation of Pressure: Effect of Latitude	104
33. Annual Variation of Mean Value of Diurnal and Nocturnal Amplitudes -	105
34. The Swinging-plate Anemometer	119
35. The Head of the Dines Pressure-tube Anemometer	120
36. The Recording Apparatus of the Dines Pressure-tube Anemometer	120
37. The Principle of the Munro-Rooker Direction Recorder	121
38. The Robinson-Beckley Self-recording Cup Anemometer	122
39. A Wind Rose (Aberdeen, July, 1919)	124
40. Diurnal Variation of Wind on the Eiffel Tower	125
41. Diurnal Variation of Wind Velocity for January and July (Aberdeen and Kew)	127
42. Circulation of Water caused by Heating	129
43. Section of Surfaces of Equal Pressure	129
44. Pressure Gradient	130
45. Effect of the Earth's Rotation	131
46. Resultant Motion	132
47. Cyclonic Motion	133
48. Anticyclonic Motion	133
49. Circulation of the Atmosphere (Ferrel, 1889)	135
50. Circulation of the Atmosphere at the Surface and in the Upper Layers	138
51. Effect of Land and Sea Breeze	144
52. Heating Effect of a Valley	145
53. The Recording Hygrometer, M.O. Pattern	100
54. Wet- and Dry-bulb Psychrometer	150
55. Trace showing Relative Humidity at Aberdeen, September 1st to 8th, 1919	155
56. Diurnal Variation in Relative Humidity for January and July (Aberdeen and Kew)	156
57. Annual Variation in Relative Humidity (Aberdeen and Kew)	157
58. Condensation Diagram (modified from the Neuhoff-Hertz Diagram)	159
59. Theoretical Diagram for the Fineman Nephoscope	169
60. Campbell-Stokes Sunshine Recorder	174
60(a). Showing Adjustment for Latitude	175
61. Isotherms of Sea Temperature, July 25th, 1913, and Path of Surface Air from July 19th to July 25th	179
62. Distribution of Temperature during Kite Ascent, July 25, 1913	180
63. Rain-gauge and Glass	186
64. Rainfall Trace, Aberdeen, November 17th to 18th, 1919	186
65. Diurnal Variation of Rainfall for January and July (Aberdeen and Kew)	187
66. Annual Variation of Rainfall and Departure from the Mean (Aberdeen, Kew, and Valencia)	188

Fig.		Page
67.	Snow Crystals - -	194
68.	Hailstones - -	197
69.	Passage of a Depression, 2nd to 4th April, 1919 - -	199
70.	Effect of Curvature of Path	203
71.	Depression approaching the British Isles	209
72.	Air Trajectories in the Depression, 11th to 13th November, 1915	211
73.	Distribution of Weather with Reference to the Centre of the Depression, 11th to 13th November, 1915	213
74.	Paths of Depressions approaching Western Europe, 1918	215
75. } 76. }	Showing Passage of the Depression, 11th to 13th November, 1915	{ 218
		{ 219
77.	Various Groupings of Isobars -	226
78.	Line Squall of 8th February, 1906 (Lempfert and Corless) -	246
79.	Circulation of Air in a Line Squall	248
80.	Dines Meteorograph for Ballons-sondes - -	262
81.	Meteorograph Record - -	262
82.	Spider Frame for Meteorograph -	262
83.	Vertical Distribution of Temperature and Pressure in a Cyclone and an Anticyclone - -	275
84.	Theodolite and Pilot Balloon -	280
85.	Diagram showing Method of Calculation	279
86.	Calculating Table	284
87.	The Distortion of Equipotential Surfaces -	295
88.	The Flame Collector	296
89.	Electroscopes	296
90.	The Dolezalek Electrometer	296
91.	Ebert's Aspiration Apparatus - -	306
92.	Wilson's Apparatus	310
93.	Window-pane Pierced by Lightning -	316
94.	Halo and Accompanying Phenomena	329
95.	Passage of a Ray of Light through a Raindrop	336
96.	Theoretical Diagram of the First Purple Light	342
97.	Theoretical Diagram of the Second Purple Light	343
98.	Location of a Source of Sound	348
99.	Arrangement of Microphones in Sound-ranging	349
100.	Storm Signals	361
101.	Weather Types: (a) Southerly; (b) Westerly	364-5
102.	Weather Types: (a) Northerly; (b) Easterly	366-7
103.	Weather Types: (a) South-westerly; (b) Anticyclonic -	368-9

LIST OF CHARTS

CHART	Page
I. Annual Isotherms - - - -	81
II. Isothermal Lines for January - - - -	83
III. Isothermal Lines for July - - - -	84
IV. Annual Isobars - - - -	112
V. Isobaric Lines for January - - - -	115
VI. Isobaric Lines for July - - - -	116
VII. Wind Circulation over the Atlantic (January-February)	140
VIII. Wind Circulation over the Atlantic (July-August) -	141
IX. Annual Mean Rainfall over the British Isles -	191
X. Annual Mean Rainfall over the Globe - - - -	193
XI. Regions and Trajectories of Tropical Cyclones - - - -	237

LIST OF TABLES

TABLE	
I. Hourly Mean Values of Temperature for August (Aberdeen)	20
II. The Composition of the Atmosphere	29
III. The Distribution of the Component Gases -	32
IV. The Number of Dust Particles in the Atmosphere	34
V. Insolation reaching the Earth on Different Dates and in Different Latitudes	44
VI. Radiation Transmitted: Effect of the Sun's Altitude and of the Transparency of the Atmosphere	46
VII. Average Monthly Temperature Values (Aberdeen and Kew)	73
VIII. Amplitudes of the Barometric Oscillations for Different Months of the Year (Aberdeen and Kew)	103
VIII(a). Monthly Averages of Pressure (Aberdeen and Kew)	107
IX. Variation of Pressure with Latitude and Altitude	113
X. The Beaufort Scale -	119
XI. Table for Wind Rose, July, 1919, Aberdeen -	124
XII. Glaiser's Factors	152

TABLE		Page
XIII.	Cloud Heights - - - - -	167
XIV.	Percentage of Total Cloud Amount over N.E. France, 1916 to 1918	176
XV.	Relation of Surface Wind to Geostrophic Wind over the North Sea -	205
XVI.	Relation of Surface Wind to Geostrophic Wind at Pyrton Hill and Southport	206
XVII.	Relation of Surface Wind to Geostrophic Wind on the East Coast - - - - -	207
XVIII.	Relative Frequency of Tropical Cyclones	239
XIX.	Mean Temperatures - - - - -	267
XX.	Mean Temperature Gradients - - - - -	268
XXI.	Mean Pressures - - - - -	272
XXII.	Mean Pressures and Temperatures in Cyclones and Anticyclones -	274
XXIII.	Correlation Coefficients	277
XXIV.	Pressure and Temperature Distributions determined by Pilot Balloon Observations on 23rd, 25th, and 28th May, 1914 -	289
XXV.	Values of λ , λ_+ , λ_- , and λ_+/λ_-	306
XXVI.	Intensity of Twinkling	325
XXVII.	Relation between the Altitude of the Sun and the Angular Distance of Parhelia - - -	329
XXVIII.	Duration of Twilight in different Latitudes -	341
XXIX.	The Probability for a Rain-day -	370

METEOROLOGY

CHAPTER I

Introduction

A.—HISTORICAL

Early Evidences.—From the earliest times the phenomena taking place in the atmosphere have occupied the attention of man. The changes in the state of the atmosphere were watched, and there arose in consequence a sort of weather lore. In some of the oldest books of the Bible, especially in the book of Job, one can see that this weather lore had even then taken definite form, and some of the information given there is even after the lapse of three thousand years found to be perfectly sound.

First Definition of Wind.—In the writings of Homer and Hesiod there is also to be found much weather lore. The first series of regular observations we owe probably to the Greeks, for as early as the fifth century B.C. almanacs, known as *parapegmata* (Gr. *παραπήγματα*), were fixed on public columns, giving mainly wind directions. During the same century the first scientific designation was given to the wind by Anaximander of Ionia, who defined the wind as “a flowing of the air”, which definition holds to the present day. At Athens was built the Tower of the Winds, octagonal in shape, with its various faces looking towards N.E., E., S.E., S., S.W., W., N.W. and N. respectively. At the top of each face was carved a figure, which may probably be considered as representative of the wind blowing from the direction towards which it looked; e.g. on the northern face the figure was clad in warm winter clothing, and his cheeks were distended as he blew

lustily through a trumpet. Such a figure may therefore be regarded as symbolical of the cold, strong northerly winds. This tower, however, was built inside the city in the market-place, and contained a water clock. Further, it is recorded that in order to obtain wind directions, observations were made outside the city on open ground. Consequently this tower was probably used rather as a time-piece than as a station for the observation of wind and weather, and the builder simply carved these symbolical figures on the faces by way of decoration.

Greek Influences.—Since the Greeks were in the habit of making regular observations of the wind, it is rather striking that no word for wind-vane has come down either from them or from the Romans. To the Greeks, however, we owe the word Meteorology, as it is derived from *τα μετέωρα*, meaning “the things above”. This at first included the study of comets and meteors, and no clear conception of the atmosphere was formed by the ancient Greek philosophers. They formed various theories about atmospheric phenomena, but during the time of Socrates meteorology had fallen greatly into disrepute.

Aristotle.—A century later came Aristotle, one of the greatest geniuses the world has ever seen. His treatise on the winds is the oldest in existence. Hellmann in his lecture before the Royal Meteorological Society, March, 1908, “The Dawn of Meteorology”, says that Aristotle’s most distinguished successors, Theophrastus and Posidonius, added but little to it. All European textbooks issued from Aristotle’s time until the end of the seventeenth century are exclusively based on his writings. His conception of the atmosphere was, however, rather strange when viewed in the light of modern developments. The atmosphere he considered divided into three regions: (1) The region in which plants and animals live, immovable like the earth on which it rests; (2) an intermediate region intensely cold; and (3) a third region contiguous to the region of fire or the heavens, and partaking of the diurnal motion of the latter. Comets and meteors were regarded as exhalations or vapours ascending from the earth and becoming heated and incandescent on reaching this region. When observations were wanting in support of any particular theory, their place was filled by imagination.

Hellmann¹ also points out that, in the third century B.C., Philo of Byzantium and Hero of Alexandria describe a primitive kind of

¹ *Quar. Jour. Roy. Met. Soc.*, Vol. XXXIV.

thermoscope. A treatise by Hero on pneumatics was in the last quarter of the sixteenth century translated into Italian and Latin, and was studied by Galileo, Porta, and Drebbel, giving to all the idea of constructing a thermoscope.

From the time of Aristotle until the beginning of the seventeenth century little progress was made. During that period no true conception of the motion of the atmosphere as a whole was formed. Probably Posidonius had formed some idea of the height of the atmosphere, but nothing that is of any real value has come down to us from these early times. It is reported that some Arabian geometers during the eleventh century A.D. estimated the probable height of the atmosphere as 92 Km. from observations of the duration of twilight, but not until five centuries later was it re-determined by European astronomers.

Galileo and Torricelli.—Up to, and during the lifetime of Galileo, who was professor of Philosophy and Mathematics at Florence, it was supposed that water rose in a pump because nature abhorred a vacuum. One day, however, some men came to him wishing him to explain to them why they could not raise water by an ordinary pump more than 18 cubits above the surface of the water in the well. He appears to have been puzzled, and gave them as a probable reason that perhaps nature did not abhor a vacuum above that height. This answer, however, did not satisfy Torricelli, who was a pupil of Galileo at the time, and who afterwards succeeded him in the professorship at Florence. Consequently he set himself to work to find out the true solution if possible. After years of labour he was able, by means of his historical experiment, which resulted in the invention of the barometer, to demonstrate that the atmosphere could be weighed, and that it exerted continually a certain pressure. In the last decade of the sixteenth century a crude kind of thermometer was invented. Whether the invention of the thermometer was due to Galileo alone, or to the combined efforts of Galileo and Sanctorius, who was then a pupil of the former, and who afterwards became professor of Medicine in the same university, is uncertain. The invention of these two instruments, the barometer and thermometer, marks the beginning of a new era in meteorology.

THE FIRST PERIOD.—The first period in the development of meteorology may therefore be said to date from very ancient times until about A.D. 1600. During this period certain qualitative

observations were made. The observations and methods were crude, and though some useful information was obtained, yet as the observations were nearly all made without instruments, many of them were inaccurate, and were often influenced by superstition, while the explanations were often fantastic and supernatural.

Early Rainfall Records.—During this period the only quantitative observations that have come down to us are those of rainfall. In the first century A.D., records of rainfall were made in Palestine. "The great influence of rainfall on the crops," says Hellmann, "must have been fully appreciated at an early date, and the results of which observations are preserved in the *Mishnah*, a collection of Jewish religious books apart from the Bible."

Another instance of rainfall records taken during this period is given by Dr. Y. Wada¹, director of the Korean Meteorological Observatory. He has shown that rain-gauges were in use in Korea as early as 1442. Both these examples show that the people of those days felt how great a part the amount of rainfall played in determining the yield from the soil.

THE SECOND PERIOD.—With the invention of instruments, the second period of meteorology begins. In addition to the two instruments already mentioned, the first European rain-gauge is said to have been invented by an Italian, Benedetto Castelli, in 1639. At this time, i.e. during the first half of the seventeenth century, meteorology owed much to the labours of the Accademia del Cimento. This group of investigators consisted of nine Florentine scholars, who were nearly all pupils of Galileo, and through their labours considerable progress was made.

In 1653 Ferdinand II, Grand Duke of Tuscany, established several stations throughout northern Italy for the purpose of making careful meteorological observations, and the first attempt to establish an international meteorological system of observations is due to him.

From the beginning of the seventeenth century thermometers had been in use in Italy. From there, Southwell brought to England in the year 1650, a thermometer of the Florentine type, the first seen in this country. Soon after this, various instruments, such as thermometers, barometers, rain-gauges, and wind-vanes were in use, and even dew collectors. Progress continued to be rapid, and Boyle, who had made duplicates of the thermometer

¹ *Quar. Jour. Roy. Met. Soc.*, Jan., 1911.

brought by Southwell, published in 1662 the law governing the compressibility of air, or of any gas, a law which has come to be known as Boyle's Law.

Halley.—In this period another great step was made when Halley published, in 1686, in the *Philosophical Transactions*, his celebrated memoir, entitled "An historical account of Trade Winds and Monsoons observable in the seas between and near the Tropicks, with an attempt to assign the phisical cause of the said winds". Alexander the Great is said to have brought back to Greece, after his invasion of India, information concerning the monsoons. Aristotle has described them, and they had been observed by the Arabs. In his book on the navigation of the Indian Ocean, published in 1554, Sidi-Ali gave the time of their commencement at about fifty different places. Towards the end of the sixteenth century Christopher Columbus, on his voyage of discovery of America, encountered the winds which later came to be known as the Trade Winds. Thus, though many of the prevailing winds came to be known before Halley's time, no real attempt at an explanation of them was given until the publication of his famous memoir, in which he pointed out that these winds were primarily due to the difference of temperature between the equator and the poles; and to the excessive heating and cooling of the land as compared with the sea.

Hadley.—The next step in this direction was made by Hadley when, in 1735, in the *Philosophical Transactions*, he demonstrated the effect of the rotation of the earth on the direction of the Trade Winds. He took account of winds blowing in a north and south direction only, however, and thus, though the germs of the explanation were given in Hadley's paper, yet it was not until much later that the full explanation was arrived at. In this direction but little progress was made further until about the beginning of the nineteenth century.

Early Investigations of the Upper Atmosphere.—In 1749 Wilson of Glasgow succeeded in raising thermometers into the air by means of a kite. This is the first record of any meteorological observations having been made above the surface of the earth. Thereafter occasional use was made of kites and balloons to carry thermometers, barometers, and hygrometers to determine the conditions in the upper air, but no systematic investigation was undertaken until near the end of the last century. Franklin, in 1752,

made use of a kite in his famous experiment on electricity in thunderstorms, and his methods were adopted by others.

The second period in the history of meteorology, which may be said to close towards the end of the eighteenth century, is marked, therefore, by the invention of a large number of instruments and an ever-increasing number of observations. As is to be expected, with the invention of instruments the accuracy in the observation of the atmospheric phenomena increased considerably.

THE THIRD PERIOD.—This was a period which sought to furnish logical explanations of the phenomena which had been observed during the second period. In the seventeenth century Halley, and Hadley in the eighteenth, had each endeavoured to give an explanation of the circulation of the atmosphere.

Dove.—During the early part of the nineteenth century, Dove, a German meteorologist, endeavoured to give a fuller explanation of the wind system, both as regards the major and minor circulations. According to Dove there were two major circulations on each hemisphere, one between the thermal equator and the tropics, the other between the tropics and the pole. The storms of temperate zones were, according to him, due to the continual strife between the warm moist south-west wind coming from the tropics and the cold dry north-east wind coming from the pole.

Maury.—In America, Maury arrived at conclusions analogous to those of Dove. In his idea of the general circulation there was this difference, however, viz. that he regarded the circulation as being confined not to one hemisphere, but considered that the air passed from one hemisphere to the other, thus giving a continual oscillation of air from pole to pole.

Redfield.—These ideas dominated the scientific world for a considerable time, but at the present day they have no supporters among meteorologists. While Dove in Europe was engaged with the problem of the origin of cyclones, Redfield took up the same problem in America. Whenever a storm took place in the Antilles or on the Atlantic coasts of North America, he procured all the observations made during the storm both on land and on sea, and plotted these on a chart. He arrived at the following conclusion, viz. that "the cyclone is constituted by a considerable mass of air endowed with a rapid movement of rotation in the direction opposite to the hands of a watch, but having at the centre a calm region".

Piddington.—The study of storms in the western Atlantic by Redfield was pursued farther by Reid. He was able to confirm Redfield's results. Under his influence the study of storms in the Indian Ocean was undertaken, and the work was entrusted to Piddington in 1838. The latter published a large number of memoirs, and finally collected his results into the book, *Sailors' Horn-Book for the Laws of Storms in all parts of the World*. He insisted that the wind round the centre of a storm has an inclination inwards, and that the air moves in consequence in spirals towards the centre.

During this same period we have the study of monsoons by Keller and Thom, and at the same time Meldrum, in Mauritius, was engaged in the study of cyclones in the Indian Ocean.

Brandes.—While the question of the origin and behaviour of cyclones was being actively pursued in this period, there belongs to it also the introduction of synoptic charts. In Germany, H. W. Brandes published in 1820 *Contributions to Meteorology* (*Beiträge zur Witterungskunde*, Leipzig, 1820); and, in 1826, *Physical dissertation on the rapid variations of the pressure of the air* (*Dissertatio physica de repentinis variationibus in pressione atmosphaerae observatis*; *Theses*, Leipzig, 1826). The first contained a study of the weather over Europe on each day of the year 1783, the observations having been published in the *Mannheimer Ephemeridien*. In his researches he made use of synoptic charts, being the first to do so, but unfortunately he did not publish specimens of these charts. As a result of his work he arrived at certain important conclusions, as we shall see later. Redfield in his work also made use of synoptic charts, but as Brandes had already published his first book in 1820, whereas Redfield's work dates from 1821, the honour rests with Brandes of being the first to use synoptic charts.

Espy.—Two other Americans contributed largely to the advancement of meteorology in the first half of the nineteenth century, viz. J. P. Espy and E. Loomis. The former organized and directed the meteorological stations in Pennsylvania, and in 1843 he was made Chief of the Meteorological Bureau of the War Department of the United States. Thus he began the organization of the meteorological service of the United States, a service which has become one of the biggest in the world. The results of Espy's work may be summarized briefly thus:

1. "The movement of the air towards the centre of the cyclone.
2. "The low barometer at the centre.
3. "The central ascending current.
4. "The formation of a cloud at a certain height, and its dispersal after it has reached a considerable height; dispersal accompanied by rain.
5. "The displacement of the whole cyclone caused by the upper currents of the atmosphere."

Loomis.—Loomis, in three publications between 1836 and 1859, improved considerably the method of treating meteorological problems by means of synoptic charts. Especially was this the case in the last two publications.

THE FOURTH PERIOD.—This period dates approximately from 1850 to 1865, and though a short period, it is a very important one for meteorology. With it are associated the names of Fitz-Roy, Le Verrier, Buys Ballot, and Ferrel.

During the decade 1840 to 1850, the idea of using telegraphy in order to obtain at a central station observations made over a wide area was gradually gaining ground. The first application of telegraphy to meteorology was made in the United States of America in 1849. The previous year a report on the use of telegraphy for meteorological purposes was read before the British Association at Swansea. Then, in 1851, at the Exhibition in London, a chart was published daily for over two months (8th August to 11th October), giving the barometric pressure unreduced and the direction of the wind for twenty-two stations. When this publication ceased there was no regular issue of daily weather reports in Great Britain until 1872. But though there was no regular weather service instituted at that time, research was being pushed forward actively. In the fifties there were published the researches of Martin and Webster, while in 1863 appeared Sir Francis Galton's *Meteorographica*. In this treatise he dealt with the circulation round centres of low pressure and also round centres of high. "I have deduced," he says, "from these charts, as I have explained in a small memoir¹ read before the Royal Society, the existence not only of cyclones, but of what I dare to call anticyclones."

Fitz-Roy.—While these investigations were in progress the British Government organized, in 1854, a section of the Board of Trade, with Admiral Fitz-Roy in charge, for the special study of

¹ *Proceedings, Royal Society, 1863, p. 385.*

meteorological questions. In 1857 Fitz-Roy arranged for observations to be taken simultaneously over the area included between the parallels of latitude 40° to 70° N. and longitude 10° E. to 30° W. It was in this period that the great storm, known as the Royal Charter Storm, took place on 25th October, 1859. From that time people began to make more practical use of the meteorological information already collected. Great Britain and Ireland were divided into three weather districts, and by 1861 Fitz-Roy had sufficient confidence to forecast a storm which took place in February. Six months later the number of observing stations was largely increased, and there was a desire to have a daily weather chart published, but owing to the lack of funds this was not done until 1872. Thus Great Britain, which had published the first daily weather report during the 1851 Exhibition, was left behind by France, where, from 1863 onwards, a daily weather report was published.

Le Verrier.—In France during this period Le Verrier was eagerly advancing the interests of meteorology. The storm which occurred in 1854 in the Black Sea, causing loss to the allied navies there, gave him his chance. A system of stations was organized, and reports and warnings were furnished to the various French ports. Finally, in 1863 he was able to have a daily weather report issued, a publication which has remained unbroken from that time to the present day.

Buys Ballot.—While Fitz-Roy in England and Le Verrier in France were advancing meteorology in their respective countries, Buys Ballot was engaged on the same question in Holland. He organized the service there, and, from a close study of observations, he arrived at his famous law, viz.: "If you stand with your back to the wind in the Northern Hemisphere, then the low pressure will be on your left hand". Though other investigators had in a manner recognized this before, yet, as Buys Ballot based all his work on this law, to him must go the honour of discovering it. The law was first published in 1860.

Ferrel.—Ferrel in America was meanwhile actively engaged in the solution of the question of the wind circulation of the globe. He published two theories at that time, one in 1856 and the other in 1860. The part played by Ferrel will, however, be discussed more fully when the general circulation of the atmosphere is considered.

THE FIFTH PERIOD.—The fifth or modern period of meteorology may be said to commence about 1870. Buchan in Scotland, Jelinek in Austria, Mohn in Norway, and a little later Hildebrandsson in Sweden, prepared the way for the great development in meteorology which has taken place within recent years. Between 1860 and 1870 Buchan published several memoirs. In 1867 he published the first charts of monthly isobars, whereby one can see that the pressure over Europe diminishes gradually from the south to the north all the year round, with a permanent low pressure in the neighbourhood of Iceland, and the relation between wind velocity and pressure gradient was demonstrated in this way.

To give a detailed account of the progress of meteorology during the last fifty years is beyond the scope of an historical introduction. The number of observations began to be multiplied, and ever greater accuracy was aimed at in the taking and treatment of these observations. All hypotheses formerly put forward began to be rigidly tested in the light of the ever-increasing information obtained. Meteorological services were established in one country after another. The British service, which was begun under Fitz-Roy in 1854, was reorganized after his death in 1867, and placed under a committee of the Royal Society, with Mr. R. H. Scott as director. This was again reorganized in 1877. On the retirement of Scott, Sir Napier Shaw became director. He in turn was succeeded by Dr. G. C. Simpson, F.R.S., in 1920.

The relation of wind velocity to barometric gradient was, as stated, demonstrated by Buchan. This problem has been discussed by many others, among whom may be mentioned Guldberg, Mohn, Sprung, Ekholm, Shaw, and Gold. In 1893 Shaw showed the necessity of calculating and utilizing gradient wind velocities. With the ever-increasing demand for information regarding conditions of wind in the upper air, a knowledge of the gradient wind is essential.

Investigation of the Upper Atmosphere.—In 1862 a notable ascent had been made by Glaisher and Coxwell in a balloon, the estimated height reached being 11,200 m. Various other ascents were made between that time and the end of the nineteenth century, but it was not until the last decade of the century that great attention began to be paid to the upper atmosphere. The work was energetically pushed forward by Rotch, De Bort, Assmann, Dines, and many others, until the beginning of the great

European War in 1914. The observations were carried out at first by means of box-kites and manned balloons. Later *ballons sondes* were employed whereby it became possible to investigate to a height of 18 Km. or more. These carried self-recording instruments, and records of pressure, temperature, and humidity for the various layers of the atmosphere were thereby obtained. By this means De Bort was able, along with Hildebrandsson, to give a new solution to the problem of the circulation of the atmosphere. All attempts at a solution hitherto had been based on certain hypotheses. Their solution is built up from facts observed.

Stratosphere and Troposphere.—In a communication to the Société de Physique in June, 1899, Teisserenc de Bort stated that by means of *ballons sondes* he had been able to find a layer in the atmosphere in which there was practically no fall of temperature with height. This layer was reached at about 11 kilometres above the surface in temperate regions. He proposed to call this layer the "Isothermal Layer of the Atmosphere" It was not until some years later that its existence was proved also over the Equator. There, from observations made at Batavia, the height was found to be 17 Km. above the surface. The name now generally applied to this layer is the stratosphere, while the layer underneath, in which the temperature falls off with height, is known as the troposphere.

If only the direction and velocity of the wind were required, small rubber balloons, called pilot balloons, were used, and thus, by the aid of two theodolites placed a known distance apart, the information required could be obtained. From observations with these and with *ballons sondes* Cave¹ has given an account of the structure of the atmosphere in clear weather.

During the last few years aeroplanes have been pressed into the service of meteorology, so that a rapid determination of pressure, temperature, humidity, wind direction and velocity in the upper layers up to 20,000 or 25,000 ft. could be obtained.

The motion of clouds has long been studied with a view to determining the currents in the upper atmosphere, especially those layers in which cirrus clouds form. So, lately, adopting the same method of observation, the direction and the velocity of the wind in layers at various heights have been determined by the observation of smoke from shell-bursts.

¹ *Structure of Atmosphere in Clear Weather*, Cambridge University Press, 1912.

For the complete equipment of an observatory in the near future there will be necessary not only what was required in the past, but aeroplanes with full equipment of instruments and an anti-aircraft gun with its crew, in order that proper investigation of the upper atmosphere may be made.

Relation to other Sciences.—Thus meteorology, though it has formed part of human knowledge from antiquity, can, as a science, be said to date only from about the end of the seventeenth century.

Of chemistry it partakes but little, but it is very closely related to physics. Many of the fundamental laws of this latter science find their expression in the phenomena exhibited in the atmosphere. So close is the relation between the two sciences that meteorology is sometimes regarded as the physics of the atmosphere. For the student who intends studying meteorology, therefore, it is absolutely essential that he should first of all obtain a good grounding in general physics. He must be familiar with such terms as mass, volume, density; velocity, acceleration, force, centrifugal force, gravity, weight, pressure; solid, liquid, gas; heat, temperature, convection, conduction, reflection and absorption of heat, latent heat, specific heat; radiant energy; reflection, refraction, and absorption of light; electricity and magnetism.

B.—UTILITY

Utility in Peace.—At the present day large sums of money are being spent by every state on meteorology, and as the years go on the demand for money for this purpose is ever increasing. The question then may naturally be asked, are the advantages gained comparable with the expenditure? Let us consider briefly how the existence of the individual, of the community, and in short of the world at large is dependent on the weather. In a favourable year the yield at harvest-time will be good provided that the agriculturist has done his part. In a bad season very much may depend on his seizing the proper opportunity of securing a crop. A science which is able to help the husbandman by giving him even a twenty-four hours' warning of a coming storm, or of a period of bad weather, which warning may mean all the difference between success and failure for him, is one well worthy of consideration. It requires therefore but little imagination to see how the agricultural world may be benefited by following advice given

by a meteorological institution. Frosts that are likely to cause damage to plants can be guarded against. The yield of the world's harvests may be thereby increased and the food supply of the world made surer and greater and therefore cheaper.

Further, as a nation Great Britain depends largely on her merchant fleet and on her fishing fleet. A science which will prevent the loss of even a few ships every year by giving warning of coming storms justifies itself. But these warnings must be attended to. An unheeded warning may result in disaster. The writer has in mind a case in the early nineties when an unheeded warning resulted in the loss of a fishing boat and its entire crew. It is essential, therefore, that seafaring people as a whole should have as full and as reliable information of coming storms as possible. This can only be done by having an efficient meteorological service, and for that purpose a certain expenditure becomes essential.

Within recent years flying has developed enormously. To anyone who has had the slightest connection with the practical side of this great new development, it is abundantly clear how great a part the weather conditions play. Thunderstorms with their accompanying squalls form one of the bugbears of the pilot's life. Fogs, drifting unexpectedly over his aerodrome or forming at night, are another of his difficulties. Changing currents or unexpected strong winds in the upper atmosphere may wreck an airship. And further, before an air route can be determined upon, a meteorological survey of the area over which the route is to pass must be made. These points will in a slight way serve to show the need of an efficient meteorological service.

Utility in War.—And if meteorological information is necessary in peace time it is equally so in war time. The success or failure of any particular operation may depend to a large extent on weather conditions. Gunners must have accurate information regarding wind velocity and direction, and also regarding temperature in the various layers of the atmosphere. Bombing squadrons must have like information. Without such information it is very unlikely that the Germans could have carried out the long-range bombardment of Paris in the beginning of 1918. It is only through accurate information regarding the wind conditions that gas can be successfully discharged against an enemy. Again, it requires but a thought to perceive what the effect of frost is upon transport. The greatest care must be exercised in protecting water-cooled engines. The pre-

diction of severe frosts is therefore of the greatest moment both for road transport and for aeroplanes. Everyone is familiar with the condition of highways on the occasion of a thaw following a long continued severe frost, and how impossible it is for heavy road traffic to be maintained. Consequently the prediction of thaws is of the greatest importance. These are but a few instances to which the science of meteorology may be applied with beneficial results, but they will serve to justify any expenditure which may be made in maintaining state meteorological services.

An Educated Public.—But a state service is not the only thing necessary. In order that full advantage may be obtained from the information given by the service, an educated public is required. The forecast of weather issued by any central office must of necessity be put into as few words as possible, and it is impossible to avoid the use of certain technical terms which to the ordinary man convey far less meaning than they do to the man who has had even but an elementary training in meteorology. Much can be done therefore by schools in laying the foundations of meteorological knowledge, and, with the present rapid strides in the industries enumerated above, it becomes almost imperative on universities to pay the greatest attention to the subject. There is perhaps no other subject which attracts the attention of so many people, yet perhaps there is no other subject about which so many false ideas exist. Ignorance and superstition have held the field in this sphere from the days of the Babylonians up to the present, and it is only by clear and scientific teaching that many of the old fallacies can be dispelled. This science enables the causes of the changes in the weather, which to many appear inexplicable, or to be due to supernatural agencies, to be set forth, and the individual, through knowing the reasons of the various phenomena occurring in the atmosphere, can take greater pleasure in observing them, even apart from any utilitarian point of view.

Educational Value.—Again, meteorology is useful not only in the manner indicated above, but it has in itself a great educational value. For long periods certain phenomena have been observed, and by means of these observations it has been possible to arrive at the laws governing them. There is ample scope therefore in this science for clear and logical reasoning in arriving at conclusions through facts observed. For long the observational side was probably the predominant side, but now the mathematical side of the

subject is being rapidly developed. It is becoming ever more and more essential for progress in the subject, that the research student should start out, not with an elementary training in mathematics and physics only, but with a wide and thorough knowledge of mathematical physics, especially in the domains of thermodynamics and hydrodynamics. For the student interested in mathematical physics, therefore, there is a rich field in this science.

Further, for the taking of observations, instruments are necessary, and the demand for new instruments to facilitate the explanation of phenomena not hitherto fully explained, and the improvement of existing instruments, in order to obtain greater accuracy in the phenomena already being observed, is ever increasing. This affords a field for the student who wishes to pursue the laboratory side of the subject. The clouds form an endless variety of subjects for the photographer. Some are easily dealt with, but others require all the skill of the experienced photographer to reproduce them, and their study forms an endless theme full of interest and value.

Effect on Health.—Not only does the weather affect a nation so far as its food and means of transport are concerned, but the health of a people depends to a certain extent on the weather. Certain types of disease occur frequently at certain times and under certain weather conditions. A public health officer must therefore be acquainted with any abnormalities in the weather conditions, such as excessively high or low relative humidity, rapid and excessive changes in temperature and pressure, the prevalence of fogs, for on such things the general health and fitness of the community depend.

On the other hand, if it is desired to advertise a place as a health resort, information regarding the average amount of bright sunshine, the average amount of rainfall, and the mean temperature of the district for certain periods of the year, is essential.

Criminologists have been able to show that certain kinds of crime are more frequent under some weather conditions than under others, and it is by no means an uncommon thing for a meteorologist to be called as a witness in a law-court in order to elucidate some point with regard to the weather conditions at the time of the occurrence of the case under trial.

These are a few of the uses to which meteorology may be put.

C.—METEOROLOGICAL ELEMENTS

When it is desired to give the state of weather at any particular time, at a particular place, the following elements must be enumerated: temperature, pressure, wind direction and velocity, state of sky as regards cloudiness, humidity, precipitation, visibility. In observing the cloudiness of the sky great care must be exercised in distinguishing between high, medium, and low clouds, and in determining the amount, direction, and velocity of the cloud in each

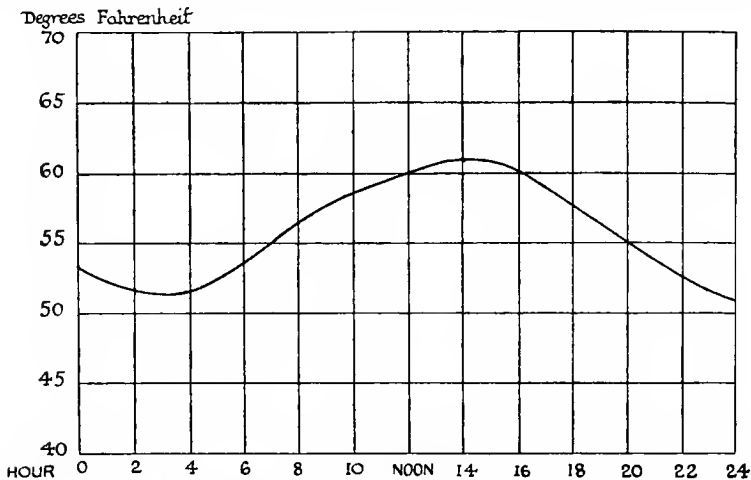

Fig. 1.—Temperature Variation at Aberdeen on 3rd August, 1919

layer. When numerical values are given to these various elements, then the weather at any particular time on any particular day is defined.

Weather and Climate.—The term weather therefore is generally used with reference to a definite day or hour of the day at a particular place. The term climate, on the other hand, is used in a much wider sense both as regards time and space. In other words it is represented by the mean values of the meteorological elements enumerated above taken over a fairly wide district and for a comparatively long period of time. Thus one can speak of the weather at Aberdeen on say, 1st August, 1919, at 7 o'clock in the morning, and of the climate of the north of Scotland during the winter time.

Periodic and Non-periodic Elements.—Of the elements mentioned above, some are periodic while others are irregular or non-periodic in their variation. If we consider the rise and fall of the temperature during the day, we find that on an average day the temperature rises during the morning and early afternoon, reaches a maximum, and then gradually falls during the late afternoon and night, reaching its minimum value just after sunrise. Fig. 1 represents this in graphical form. The period in this case is twenty-four hours, and the amplitude of the oscillation is given

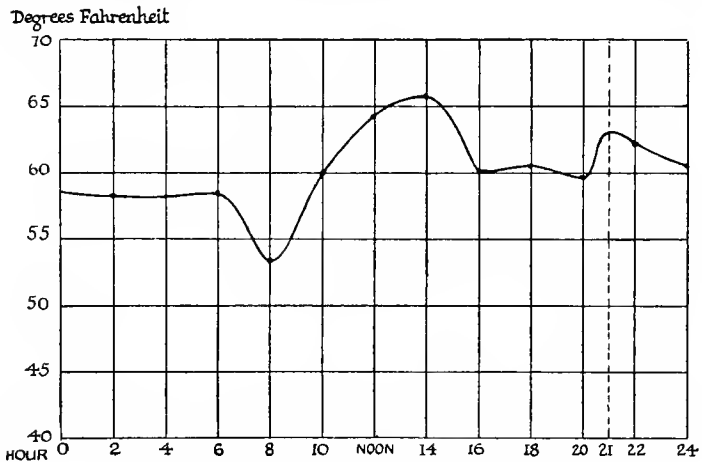

Fig. 2.—Temperature Variation at Aberdeen on 1st August, 1919

by the difference between the lowest and highest readings. Another example of periodic variation is afforded by the twelve-hourly barometric oscillation which is well marked in Equatorial regions though its effect is much less in temperate and polar regions.

A periodic variation may often be marked by means of an irregular or non-periodic variation. Thus changes of the wind, especially at a coast station, or varying cloud amount may cause sudden alterations in the temperature, and instead of having a regular variation as in fig. 1, there may be an irregular curve as shown in fig. 2. In the realm of meteorology there is never found an absolutely pure periodic variation. The nearest approach is perhaps the twelve-hourly barometric oscillation in Equatorial regions, which occurs at times with almost sufficient regularity

to enable an observer to tell the time of day by it. With the meteorological elements, however, it is almost invariably a combination of periodic and non-periodic variations going on simultaneously that we have to deal with, and one of the first problems that presents itself is the separation of the non-periodic variations from the periodic, from a series of observations. This may be accomplished by the method of Mean Values, but though this method is very helpful in many cases, care must be taken not to apply it in cases which are not suitable.

D.—METHODS OF INVESTIGATION

Mean Values.—Suppose that we have a certain meteorological element which is found to vary with the time and that we wish to find its mean value.

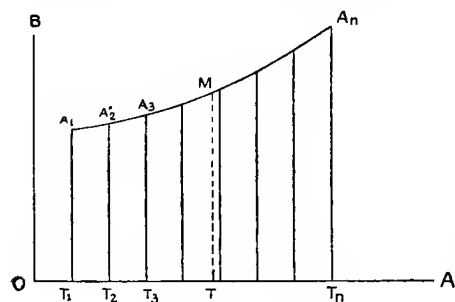

Fig. 3.—Mean Values

This may be done graphically. Let the varying element be the temperature, and let its observed values at times $t_1, t_2, t_3, \dots, t_n$ be $a_1, a_2, a_3, \dots, a_n$. Take now two lines OA and OB at right angles, which we shall call the x -axis and the y -axis. Along the x -axis measure off distances $OT_1,$

OT_2, \dots , proportional to t_1, t_2, \dots , and at T_1, T_2, \dots erect perpendiculars proportional to a_1, a_2, \dots , viz. T_1A_1, T_2A_2, \dots . Then the curve which passes through A_1A_2, \dots will represent graphically the manner in which the temperature varies with the time. When we examine fig. 3 it is seen that a certain area is enclosed by $T_1A_1A_nT_n$, and further that this area is made up of a number of small figures such as $T_1A_1A_2T_2$. The area of $T_1A_1A_2T_2$ is equal to the product of T_1T_2 multiplied by the average height of the figure, and if the points T_1, T_2 be taken sufficiently close together this height is approximately $\frac{1}{2}(T_1A_1 + T_2A_2)$. Similarly an average value could be found for all the heights. Suppose that this average height is TM . Then the area $T_1A_1A_nT_n$ is equal to the product of this height TM and the length T_1T_n . TM is consequently called the mean value of the heights, and in this particular case it is the

mean value of the temperature over the period considered. All the observed values may differ from this value. Some are greater, others are less than the value, and the various differences between this mean value and the observed values are known as the departures from the mean.

In employing this method the greatest care must be taken to ascertain whether the number of observations taken during the period under consideration is sufficient to justify the employment of the method, or, in other words, that the observations are sufficiently close to one another in point of time, otherwise entirely false results may be arrived at.

After a meteorological element has been observed for some time, it often becomes necessary to summarize the results obtained, and for this purpose the four following values are determined, the maximum, the minimum, the mean, and the departure from the mean. In summarizing the temperature for any particular day for example, the observed value at each of the twenty-four hours is taken and the whole added. A correction is added depending on half the difference between the readings at the commencement of the interval and at the end. The corrected sum is then divided by twenty-four, when the correct mean value is found. Symbolically this may be represented thus:

$$M = \frac{1}{24}\{a_1 + a_2 + \dots + a_{24} + \frac{1}{2}(a_0 - a_{24})\},$$

where $a_0, a_1, a_2 \dots a_{24}$ are the values of the element at 0 hour, 1 hour . . . 24 hours.

Thus on 12th August, 1919, the values at Aberdeen were:

Maximum = 295.8° A. = 73°.0 F.

Minimum = 285.6° A. = 54.7° F.

Mean Value = 290.5° A. = 63.5° F.

Departure at 10 h. from mean = 2.2° A. = 3.96° F.

Having obtained this mean value for the day, one can determine from observations for a number of years the mean value for any particular day of the year. This may be extended, using the month as the unit of time and afterwards further by using the year as the unit.

Problems Solved by Mean Values.—In order to investigate the diurnal periodicity of the temperature, one may calculate the hourly mean values throughout the month, obtaining thereby

twenty-four values or points on the curve. The hourly mean values at Aberdeen for August, 1914, were at

1 hour	285.50°A.	9 hours	287.34°A.	17 hours	288.49°A.
2 hours	85.28	10 "	87.96	18 "	88.08
3 "	85.09	11 "	88.30	19 "	87.44
4 "	84.87	12 "	88.29	20 "	86.96
5 "	84.85	13 "	88.37	21 "	86.53
6 "	85.21	14 "	88.44	22 "	86.23
7 "	86.14	15 "	88.52	23 "	86.06
8 "	286.82	16 "	288.52	24 "	285.81

This shows the daily rise and fall of temperature. If we extend this to a number of years, then the curve is seen to become smoother. By taking the mean values over the forty years 1871-1910 we have the following table. Alongside are placed the departures of the 1914 August values from the means of the forty-year period.

TABLE I

SHOWING HOURLY MEAN VALUES OF TEMPERATURE AT ABERDEEN
FOR PERIOD 1871-1910

Hour.	Mean hourly value of temp. for August.	Departure of 1914 values from 40-year means.	Hour.	Mean hourly value of temp. for August.	Departure of 1914 values from 40-year means.
1	1284.62°A.	+ .88°A.	13	288.18°A.	+ .19°A.
2	84.40	+ .88	14	88.16	+ .28
3	84.22	+ .87	15	88.11	+ .41
4	84.05	+ .82	16	87.87	+ .75
5	84.04	+ .81	17	87.60	+ .89
6	84.51	+ .70	18	87.21	+ .87
7	85.40	+ .74	19	86.71	+ .73
8	86.13	+ .69	20	86.06	+ .90
9	86.85	+ .49	21	85.63	+ .90
10	87.27	+ .69	22	85.25	+ .98
11	87.72	+ .58	23	85.01	+ 1.05
12	287.95	+ .34	24	284.78	+ 1.03

Another problem which one might investigate by this method of means is the comparative amount of rainfall for any particular month. As above it might be examined by hourly mean amounts and the departures of the values of one particular month from a series. If less detail were required the problem might be solved

by using the average daily amount. Thus if we look again at the year 1914 and the month of August, the average daily rainfall at Aberdeen for that year and month was 1.24 mm. But the forty-year period 1871-1910 gives an average daily rainfall for this month of 2.51 mm. Therefore in the month of August, 1914, the average daily rainfall was a little under 50 per cent of the normal.

Many other problems in meteorology permit of being solved in this way by mean values.

APPLICATION OF STATISTICAL METHODS TO METEOROLOGY

MEAN VALUES AND THE STANDARD DEVIATION

In the last section the method of obtaining the mean value of a series of quantities was considered, and if the number of quantities considered was sufficiently large, then certain types of problems could be solved in this way. But very often there are not sufficient data to permit of the problem being solved in this way, and it is therefore necessary to know how much reliance can be placed upon a mean value deduced from any given set of observations.

Standard Deviation.—In addition to the mean value, it is often desirable to know the extent of the variation of a quantity, and the manner of the variation. In statistics, the common standard for measuring the variation is what is called the Standard Deviation. Thus, if \bar{X} is the mean value of n values of any quantity, and if x_1, x_2, \dots, x_n , are the departures of the various values from the mean value, then the standard deviation is

$$\sqrt{\frac{x_1^2 + x_2^2 + \dots + x_n^2}{n}} = \sigma \text{ (say).}$$

In a normal distribution of the values, values above the mean are just as likely to occur as, and no more than, corresponding values below the mean. Also the theory of probabilities shows that if a quantity vary in the normal way, then departures from the mean equal to 4 times the standard deviation (S.D.) are very few, and for practical purposes are non-existent. The chances of departures 3 times the S.D. are 370 to 1 against, twice the S.D. 21 to 1 against, while the chances are even whether any particular departure exceeds or is less than $\frac{2}{3}$ S.D.

So by using the S.D. as a unit, one can estimate the chances.

The S.D. is sometimes known as the Standard Error of a quantity where the errors are casual errors, i.e. errors occurring by chance, each error being independent of the other. This type of error must not be confused with a systematic error, which arises in quite a different way. If a thermometer were wrongly graduated, no increase in the number of observations would eliminate this error. Such an error is called a Systematic Error.

When a mean is derived from a limited number of observations, it is necessary to know what the standard error of this mean is. If there be 3 quantities, X, Y, Z, such that $Z = X + Y$, then if σ_x , σ_y , and σ_z are their standard deviations,

$$\sigma_x = \sqrt{\frac{\Sigma x^2}{n}}, \sigma_y = \sqrt{\frac{\Sigma y^2}{n}}, \text{ and } \sigma_z = \sqrt{\frac{\Sigma z^2}{n}},$$

where x, y, z are the corresponding departures of each from its mean value. These departures are so related that $z_1 = x_1 + y_1$, $z_2 = x_2 + y_2$, &c.

$$\therefore \Sigma(z^2) = \Sigma(x^2) + \Sigma(y^2) + 2\Sigma(xy).$$

But if x and y are entirely independent of each other, $\Sigma(xy)$ will be negligible compared with $\Sigma(x^2)$ and $\Sigma(y^2)$.

$$\therefore \sigma_z^2 = \sigma_x^2 + \sigma_y^2.$$

If X and Y are exactly similar, then $\sigma_x = \sigma_y$, so that $\sigma_z^2 = 2\sigma_x^2$. Similarly for any number n of quantities.

$$\therefore \sigma_z^2 = n\sigma_x^2.$$

Z is the sum of all the quantities, and the mean is Z/n , so that the standard error of the mean is

$$\frac{\sigma_z}{n} = \frac{\sigma_x}{\sqrt{n}}.$$

If the quantities were not independent, this result would no longer hold, so that it is essential that the quantities be all independent. By this method, therefore, we are able to see the extent to which an average obtained from a small number of values departs from the true average.

But often the true average is not known, and so it is necessary to have some criterion to determine how great the casual difference may be between two means which ought to be the same.

As for the sum of 2 similar variables, so for their difference the standard deviation is $\sigma\sqrt{2}$. If there be two values, each derived from n causes, then the standard error of difference is $\frac{\sigma\sqrt{2}}{\sqrt{n}}$. If the difference in question exceeds this value 3 times or more, then and not till then is it necessary to consider it significant.

CORRELATION

Hitherto we have considered the variation of a single quantity; but a question often of greater interest is the connection between two or more varying quantities, and how great this connection is. The best method of finding the relation between two variables is to plot them on squared paper, but with more than two variables the method is impracticable, and instead we must form what are known as the regression equations and the correlation coefficients between the quantities.

If X and Y be two variables, and the departures from the mean values be x and y in general, but x_1y_1, x_2y_2, \dots on particular occasions, then the problem is to find some definite relation between X and Y , so that if x_1 is known, a very good guess may be made at y_1 , and so on. In a particular case $y = bx$, and the question therefore is, what value of b best fits the general conditions. In general $y - bx$ will have a certain value, either positive or negative, mostly small if X and Y are so related that on knowing one the other is almost known, but mainly large if X and Y are independent; $(y - bx)$ may be either positive or negative, but $(y - bx)^2$ is always positive, and the value of b , which makes $\Sigma(y - bx)^2$ a minimum, will be the most suitable, i.e. as $\Sigma(y - bx)^2 = \Sigma\epsilon^2$, which makes $\Sigma\epsilon^2$ a minimum.

If $\Sigma(y - bx)^2$ is a minimum, then, on differentiating with regard to b , we obtain

$$\begin{aligned}\Sigma x(y - bx) &= 0, \\ \text{or } \Sigma(xy) &= b\Sigma(x^2),\end{aligned}$$

$$\text{i.e. } b = \frac{\Sigma(xy)}{\Sigma(x^2)}, \text{ which determines } b.$$

But

$$\sigma_x = \sqrt{\frac{\Sigma x^2}{n}}.$$

$$\therefore b = \frac{\Sigma(xy)}{n\sigma_x\sigma_y} \cdot \frac{\sigma_y}{\sigma_x} = r \cdot \frac{\sigma_y}{\sigma_x}.$$

This value r is the correlation coefficient between X and Y , is a pure number, and cannot exceed $+1$ or -1 .

If the relationship between the two quantities is close its value is high, but unless it depend on a reasonably large number of independent observations, say 25 as a minimum, its value cannot be regarded as significant.

The function was first suggested by Sir Francis Galton, and was known for a time, as Galton's function. Galton also termed the relation $y = bx$ a regression equation.

There are certain limitations in drawing inferences from the value of a correlation coefficient which must be carefully borne in mind. Like other values, it is subject to standard error, and, when r is not too small, the standard error is $(1 - r^2)/\sqrt{n}$. If $n = 25$ and $r = .5$, then the standard error = $.15$, and so to make quite certain that the result is not a chance one, a value 4 times the standard error is necessary, and therefore a value of $r = .5$ on 25 observations need not necessarily be significant.

Also the observations must be independent, and care must be exercised that no secular or periodic changes have been concerned in the production of the function. With observations amounting to about 50, one may say, roughly, that values of r under $.3$ are hardly significant, values between $.3$ and $.7$ prove a moderate connection, values between $.7$ and $.9$ a close connection, while values above $.9$ show a very close relation.

PARTIAL CORRELATION

Occasionally it is not evident from the relation between two quantities what is cause and what is effect, and a relationship which may be due to some other reason may be the only thing indicated. On such a question as this considerable light may be thrown by "partial correlation".

A notation introduced by Mr. Udny Yule¹ is very suitable for use in problems of this type, and this notation we shall consider briefly.

If there be two variables, X_1 and X_2 instead of X and Y , and the departures from the mean values be x_1 and x_2 instead of x and y , then, according to Yule's notation,

$$x_1 = b_{12}x_2 \text{ and } x_2 = b_{21}x_1.$$

¹ *Proc. Roy. Soc., Series A, Vol. LXXXIX, 1907, p. 182.*

Also $x_{1\cdot 2}$ takes the place of the deviation ϵ , and the standard deviation for the expression $(x_1 - b_{1\cdot 2}x_2)$ is written as $\sigma_{1\cdot 2}$. Hence we have

$$\begin{aligned} x_1 - b_{1\cdot 2}x_2 &= x_{1\cdot 2}, \\ \text{and } x_2 - b_{2\cdot 1}x_1 &= x_{2\cdot 1}, \\ \text{i.e. } \Sigma x_{1\cdot 2}^2 &= n\sigma_{1\cdot 2}^2 = n\sigma_1^2(1 - r_{12}^2), \\ \text{and } \Sigma x_{2\cdot 1}^2 &= n\sigma_{2\cdot 1}^2 = n\sigma_2^2(1 - r_{12}^2), \\ \text{where } r_{12} &= \frac{\Sigma(x_1x_2)}{n\sigma_1\sigma_2}, \text{ and } b_{12} = r_{12}\frac{\sigma_1}{\sigma_2}, \text{ but } b_{2\cdot 1} = r_{12}\frac{\sigma_2}{\sigma_1}. \end{aligned}$$

If, then, there be three quantities, X_1, X_2, X_3 , in order to find the connection between X_1 and X_2 , any influence that X_3 may have on either must first be allowed for. For this the three primary correlation coefficients and the three standard deviations are first obtained. These values are r_{12}, r_{13}, r_{23} and $\sigma_1, \sigma_2, \sigma_3$ respectively. Then as

$$\begin{aligned} \sigma_{1\cdot 2}^2 &= \sigma_1^2(1 - r_{12}^2), \text{ \&c.}, \text{ we have} \\ r_{12\cdot 3} &= \frac{r_{12} - r_{13}r_{23}}{\sqrt{1 - r_{13}^2} \sqrt{1 - r_{23}^2}}. \end{aligned}$$

Similarly for $r_{23\cdot 1}$ and $r_{31\cdot 2}$.

In the same way the values of "b" in the regression equations of the form

$$x_1 - b_{12\cdot 2}x_2 - b_{13\cdot 2}x_3 = x_{1\cdot 23}, \text{ \&c.}$$

are

$$b_{12\cdot 3} = \frac{b_{12} - b_{13}b_{32}}{1 - b_{23}b_{32}},$$

and the two corresponding values for $b_{23\cdot 1}$ and $b_{31\cdot 2}$.

Instead of finding the values for b , the values of $\sigma_{1\cdot 23}, \sigma_{2\cdot 31}$, and $\sigma_{3\cdot 12}$ may be calculated, especially as they afford a check on the arithmetic. Here

$$\sigma_{1\cdot 23}^2 = \sigma_{1\cdot 3}^2(1 - r_{12\cdot 3}^2) \text{ or } = \sigma_{1\cdot 2}^2(1 - r_{13\cdot 2}^2),$$

and two corresponding values for $\sigma_{2\cdot 31}$ and $\sigma_{3\cdot 12}$.

The relationship between the b 's and the σ 's is expressed thus:

$$b_{12\cdot 3} = r_{12\cdot 3}\frac{\sigma_{1\cdot 23}}{\sigma_{2\cdot 31}},$$

together with corresponding values for $b_{23\cdot 1}$ and $b_{31\cdot 2}$,

For proofs of all formulæ quoted the reader is referred to text-books on statistics.

By applying these methods Dines has been able to find the relation between such quantities as the mean temperature of the

air up to 20 Km. and the pressure at 9 Km.; the height of the tropopause (see Chapter VIII) and the pressure at 9 Km. Also by partial correlation he has shown how the height of the tropopause is almost independent of the mean temperature of the air, whereas it is almost entirely dependent on the pressure at 9 Km. Thus, if H_c is the height of the tropopause, T_m the mean temperature of a column of air from the ground up to 20 Km., P_9 the pressure at 9 Km. above the ground, while " δ " denotes the variation of any quantity, then Dines finds the following relation, viz.:

$$\delta H_c = .07\delta T_m + .94\delta P_9.$$

Further examples will be given in Chapter VIII.

CHAPTER II

The Atmosphere

The phenomena with which meteorology deals all take place in the gaseous envelope which surrounds the earth, and in order to aid to a clearer conception of these phenomena, a short study of this envelope with its constituent gases is desirable.

Definition of the Atmosphere.—This envelope of colourless, tasteless, odourless gas which surrounds the earth has been called the atmosphere. When it is at rest one would almost doubt its existence, but when it is set in motion there is left no longer reason for any such doubt. As it sweeps over the surface of the earth its velocity may increase to such an extent that trees are uprooted, houses demolished, and injury done to human life, as in the tornadoes of America; or again, it may lash the sea into such a fury that the biggest ocean liners are tossed about on the waves like cockle-shells, as in the typhoons of the China Sea. On the other hand its existence is shown by the gentle breeze blowing in from the sea during a warm summer day.

Physical Properties.—Several of its physical properties were studied and the laws governing them enunciated before the composition of the gas itself was known. In 1643, when Torricelli showed that the atmosphere could support a column of mercury about 30 in. in height, he demonstrated that it could exert a certain pressure. A few years later, in 1648, Pascal, by his experiment on the top of the Puy-de-Dôme, wherein he showed that the column of mercury supported by the air at the top differed from that supported at the bottom by about 3 in. (76 mm.), demonstrated that this pressure exerted by the atmosphere decreased with height above the surface of the sea.

The invention of the air-pump by Otto von Guericke, in 1650, enabled the weighing of a definite volume of air, and some twelve

years later, in 1662, Boyle published the law known under his name, the law of the compressibility of air or any other gas.¹ Following upon this, we have the law of Gay-Lussac,² where the law of the variation of pressure *or* volume with absolute temperature is given, and then the combining of these two laws in Charles' Law.³ Another physical property which the atmosphere was found to possess in common with other gases was that of adiabatic heating and cooling. At the surface of the earth, therefore, the atmosphere as a gas possesses the following physical properties: (1) A quantity of air, when admitted into any space, fills equally all parts of the space open to it, exerting an equal pressure in all directions. (2) The volume of a given quantity of air varies inversely as the pressure upon it, provided the temperature remains constant. (3) The $\left\{ \begin{array}{l} \text{volume} \\ \text{pressure} \end{array} \right\}$ of a given quantity of air varies directly as the absolute temperature, provided the $\left\{ \begin{array}{l} \text{pressure} \\ \text{volume} \end{array} \right\}$ remains constant. (4) A given quantity of air when expanded without addition of heat becomes cooled, and, conversely, becomes heated when compressed without heat being subtracted.

Composition of the Atmosphere.—From the time that Boyle published his law in 1662 until 1784, when Cavendish published his *Experiments on Air*, many workers contributed towards the solution of the question of the chemical composition of the atmosphere. An interesting historical account of the subject is given by Sir William Ramsay in his *Gases of the Atmosphere*. Among those who contributed to the solution of the problem are to be found the names of Boyle, Rutherford, Priestley, Lavoisier, and Cavendish. To Lavoisier we owe the isolation of oxygen in its pure state from the atmosphere, and he was the first to show that water vapour must exist in the atmosphere. The composition of the atmosphere as given by Cavendish in his paper is:

79.16 per cent of phlogisticated air or nitrogen } by volume.
20.84 per cent of dephlogisticated air or oxygen }

¹ Boyle's Law may be stated symbolically thus $P_0V_0 = PV$, or $\frac{V_0}{V} = \frac{P}{P_0}$ where P_0, V_0 are the original values of pressure and volume, and P, V the final values.

² Gay-Lussac's Law, represented symbolically, is (1) $\frac{V_0}{V} = \frac{\theta_0}{\theta}$ or (2) $\frac{P_0}{P} = \frac{\theta_0}{\theta}$, in the first case the pressure being constant and in the second the volume.

³ Charles' Law in symbolical form is $\frac{P_0V_0}{\theta_0} = \frac{PV}{\theta}$ where both pressure and volume vary.

θ must be measured on the absolute scale of temperature.

According to Ramsay these values do not differ greatly from the best modern analysis if the percentages of nitrogen and argon be added and reckoned as nitrogen.

It was not until 1894 that argon was isolated from the atmosphere in experiments made by Rayleigh and Ramsay. Later, the gases neon, krypton, xenon, and helium were discovered, but only in very minute quantities, especially in the case of helium, near the surface of the earth. Hydrogen also exists in the atmosphere to the extent of about 0.01 per cent by volume. Its presence has long been known, and formerly the amount was believed to be greater than modern analysis shows. Carbon dioxide is present to the amount of about 0.03 per cent by volume, but its amount varies slightly according to locality, as we shall see later.

The Permanent Gases of the Atmosphere.—The permanent gases of the air, along with their percentage volumes, as given by Hann.¹ are as follows:

TABLE II

Nitrogen	... 78.03 per cent	Hydrogen	... 0.01 per cent
Oxygen...	... 20.99 per cent	Neon...	... 0.0015 per cent
Argon 0.94 per cent	Helium	... 0.00015 per cent
Carbon dioxide...	0.03 per cent		

The Air a Mechanical Mixture.—That these gases exist in the atmosphere as a mechanical mixture and not as a chemical compound, can be shown in several ways. (1) The proportion in which they go to make up the atmosphere is not that of their atomic weights. (2) If the various constituents are mixed, there is no evolution or absorption of heat in the process. (3) They can be separated by fractional distillation from liquid air, the gas with the lower boiling-point distilling off first. (4) Its composition can be altered by absorbing one or more of the constituents by chemicals. (5) The index of refraction of air is the mean of the indices of refraction of its constituents, due regard being paid to the different percentages of these elements.

Yet, in spite of the fact that it is a mechanical mixture, its composition at the surface remains remarkably constant. The percentage of oxygen by volume differs by less than 0.5 per cent in samples of air taken from any place on the surface of the earth, and, even in the worst samples of air taken from a mine, differs only by about

¹ *Lehrbuch der Meteorologie*, p. 5.

2.5 per cent from the normal. Under normal conditions, therefore, the variation is less than 4 per cent of its own volume.

Carbon dioxide differs slightly in amount from place to place. The total amount in the atmosphere at any time is small, approximately 0.03 per cent by volume. Over the sea the percentage is slightly greater, while over vegetation it is less. In large cities it may rise to 0.04 per cent, and in closed rooms to approximately 1 per cent if the ventilation is very bad. In a room which is properly ventilated, however, the amount should never be allowed to pass 0.07 per cent. In the process of breathing, approximately $\frac{1}{5}$ of the volume of oxygen breathed in is replaced by carbon dioxide on breathing out. Therefore, to keep the percentage of carbon dioxide small in any place the greatest care should be taken to procure efficient ventilation, so that thereby the air may be properly mixed.

Ventilation on a large scale is conducted by the winds, for the air is constantly being transported over the surface of the earth, thereby ensuring a constant mixing. Another process aiding in the proper mixing of the atmosphere is diffusion. Gases diffuse rapidly, and, even in the absence of wind, any irregularities in the composition would disappear.

Oxygen is used up by animals, as we have seen, by internal combustion in the process of breathing, and carbon dioxide is manufactured. So the green cells in the leaves of plants under the influence of sunlight absorb the carbon dioxide, using the carbon for the building of the cells of the plant and giving forth oxygen to the atmosphere. In this way the balance of oxygen and carbon dioxide is maintained in the air, and this explains why the air over green vegetation contains less carbon dioxide than does the air over cities.

Alteration of the Composition of the Atmosphere with height.—The composition of the atmosphere given in Table II refers only to air at the surface of the earth. Though the percentages given in that table remain nearly constant up to 6 or 7 miles, the greatest height at which men can live, and even with but little variation for 2 or 3 miles above that height, yet higher up according to theoretical calculations the percentage composition alters considerably. Up to about 7 miles above the earth's surface in temperate, and to rather greater heights in equatorial regions, the temperature decreases with the height above the surface, and within this region convection takes place, and the composition of

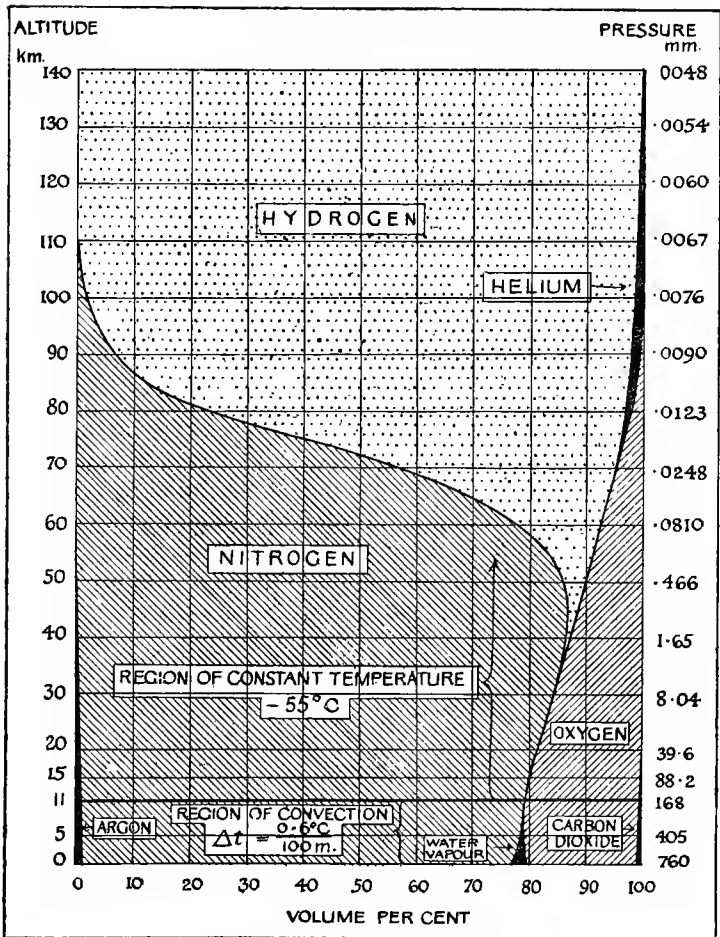

Fig. 4.—Distribution of the Gases in the Atmosphere
(After Humphreys in the *Mount Weather Bulletin*, Vol. II.)

the atmosphere remains nearly constant. Above these heights, however, there is no longer any vertical temperature gradient. Consequently the gases tend to arrange themselves in layers, the heavier nearer the earth's surface, the lighter farther away. Humphreys¹ has calculated the percentages of the various gases in the layers from 5 Km. to 150 Km. above the earth's surface.

¹ *Mount Weather Bulletin*, Vol. II, p. 66. 1909-10.

These results are given in the following table, and are represented graphically in fig. 4.

TABLE III

Height in Kilometres.	N	O	Ar.	CO ₂	H	He.
	per cent	per cent	per cent	per cent	per cent	per cent
5	77.89	20.95	0.94	0.03	0.01	0.00
15	79.56	19.66	0.74	0.02	0.02	0.00
30	84.48	15.10	0.22	0.00	0.20	0.00
50	86.16	10.01	0.08	0.00	3.72	0.03
80	22.70	1.38	0.00	0.00	75.47	0.45
100	1.63	0.07	0.00	0.00	97.84	0.46
150	0.00	0.00	0.00	0.00	99.73	0.27

Thus at heights above 100 miles the atmosphere is composed almost entirely of hydrogen and a little helium.¹

The Minor Constituents of the Atmosphere.—In addition to the gases already discussed, there are present in the atmosphere the following substances known as the minor constituents of the atmosphere, and of which the amount is variable. These are traces of nitric and sulphuric acids, ozone, organic and inorganic particles, and water vapour. The traces of acids need not concern us here.

Ozone.—This is an allotropic form of oxygen, the molecule consisting of three atoms instead of two. The third atom is loosely held, and on this account it is a strongly oxidizing agent. In the free atmosphere it is to be found near the seashore and over mountains. It derives its name from the peculiar odour it possesses (Gr. ὄζω = I smell). The beneficial effects to health often attri-

¹ Other investigators claim that the upper atmosphere consists almost entirely of Helium, Hydrogen being absent. The absence of hydrogen they account for (1) by the uncertainty in, and the smallness of, the amount of free hydrogen near the surface of the earth; (2) by the opportunities this hydrogen has of uniting with oxygen in the region of the troposphere, and in the lower portions of the stratosphere; and (3) also by the absence of any direct evidence of the existence of a hydrogen atmosphere at great heights. It has been shown, however, that hydrogen does not escape from the earth's atmosphere by reason of its small molecular weight, and therefore if it is present at the base of the stratosphere even in very small quantities, then in the higher reaches of the stratosphere the atmosphere is likely to consist almost entirely of hydrogen, as it is of less molecular weight than helium.

Pressure and density at any point depend on the mass of gas above the point. In a helium atmosphere pressure would decrease more rapidly than in a hydrogen atmosphere. If then an experimental determination of pressure or density could be made above 100 Km. or 150 Km., a great advance towards the solution of the problem would be accomplished. At the present only theoretical solutions can be given to the problem, and further investigations are required before an exact knowledge of the composition of the atmosphere at great heights can be obtained.

buted to it, however, are perhaps exaggerated, these being in all probability due to the purity of the air rather than to the presence of ozone. Its presence can be detected in the atmosphere during thunderstorms, and the air in the neighbourhood of an induction coil becomes ozonized by the passage of the electric spark through it.

Solid Particles in the Atmosphere.—These are of two kinds, organic and inorganic. The number of organic particles in the air is comparatively small. They consist mainly of spores of plants and bacteria. In the air over cities they are more plentiful than over open country, while over the open ocean their number is probably of the order of 1 per cubic metre. In crowded places their number may reach to 3000 per cubic metre, and in hospital wards this number may be far exceeded. The inorganic particles are, however, much more numerous than the organic particles. They are generally spoken of as dust, and their presence in the atmosphere is due to several causes. (1) They are raised into the atmosphere from the surface of the earth by the wind. (2) They are thrown up by volcanoes when in eruption. (3) They pass into the atmosphere as smoke by the combustion of fuel on the earth's surface. (4) They are carried into the atmosphere in ocean spray. (5) Meteors on passing through the atmosphere become incandescent and disintegrate, adding large quantities of dust to the upper atmosphere.

Counting the Dust Particles.—Aitken's Dust Counter. The counting of these dust particles has engaged the attention of many investigators. Probably the best method at the present day for counting them has been devised by Aitken by means of his dust counter. This instrument consists essentially of a glass box about one centimetre thick. On the bottom of this box is a plate divided into square millimetres, and this plate can be illuminated by means of a mirror. The plate is viewed from above by means of a lens fixed on the top of the box. The air inside the box is kept moist by means of two pieces of filter paper saturated with water and attached to the sides. To the box is attached a pump with a graduated portion, so that any known volume of air may be removed from the box. When some air is removed by means of this pump, the air left inside expands and becomes colder, and some of the moisture condenses on the dust particles and forms a cloud which gradually settles on the plate. In this way the dust particles

can all be removed from the air in the box and their number counted. A sample of air can now be admitted into the box which contains only dust-free air. The whole is shaken up to ensure proper mixing and thorough saturation with moisture of the new air. On further exhaustion the dust is carried down by the moisture condensing on it, and thus the number of particles can be counted.

Number of Dust Particles.—Over the ocean and in the atmosphere above mountain ranges, the number of these particles is very small compared with their number in the air over a city. There they are of the order of 100,000 per cubic centimetre, whereas over the ocean their number is of the order of 500 per cubic centimetre over the Indian Ocean to 2000 per cubic centimetre over the Atlantic. Some of the values given by Aitken for samples of air taken from various sources are shown in the following table.

TABLE IV
NUMBER OF DUST PARTICLES IN AIR

Source.	Number per cubic centimetre.	Wind { Direction. Force.	Weather, &c.
Ben Nevis	400	S.W., 1	Hazy.
Edinburgh	75,000	W., 3	{ Air clear, passing snow-showers.
"	250,000	N.W., 1	{ Fair, but air thick.
Meeting-room	275,000		{ 4 feet from floor before meeting.
"	400,000		{ 4 feet from floor near end of meeting.
"	1,800,000		{ Near ceiling at beginning of experiment.
"	2,300,000		{ Near ceiling after gas burning 2 hours.

He further estimates¹ that with every puff of smoke, a cigarette smoker sends 4,000,000,000 of these particles into the air.

Some of the larger dust particles may be seen in a beam of sunlight as it streams through an opening into a room.

These particles play an important part in various meteorological phenomena. (1) They are the chief cause of haze in dry warm weather. (2) They form nuclei on which water vapour condenses to form fogs and rain. Aitken discovered the necessity of a nucleus

¹ *Proc. Roy. Soc. of Edin.*, 4th Feb., 1889,

as a first step in the formation of cloud particles, and it was thought that these dust particles were the only source of nuclei, and that their presence was essential for condensation. Later, however, it has been shown that gaseous particles will produce the same effect, and C. T. R. Wilson has shown that when air becomes ionized, these ions are efficient nuclei. (3) They are to a large extent the cause of twilight. (4) To them are due in part the colour at sunrise and sunset, and also the blue colour of the sky.

The first two cases will be dealt with more fully in Chapter VI, "Water Vapour in the Atmosphere", and the second two in Chapter X, "Atmospheric Optics".

Water Vapour.—The other variable constituent of the atmosphere is water vapour. Its amount¹ is small, never exceeding 4 per cent by volume, even in tropical regions, and in temperate latitudes scarcely ever exceeding 1 per cent. It is confined to the lower layers of the atmosphere, the highest clouds scarcely ever exceeding 8000 or 9000 m., unless perhaps in tropical regions. Yet though its amount is comparatively small it plays a very important part. Without it, plant and animal life would be impossible. All the phenomena of dew, clouds, rain, hail, snow, and frost are due to it. It makes possible the rainbow and the halo, and were it not for it there would be no thunderstorms. A large section of meteorology is devoted to its study, as will be seen in the following chapters.

The Height of the Atmosphere.—From time to time astronomers have made various calculations of the height of the atmosphere. As early as the eleventh century A.D. certain Arabian geometers are said to have calculated its height, giving as the value 92 Km., but their results seem to have been lost for several centuries. They based their calculations on the observation of the duration of twilight. About five centuries later European astronomers made a determination of the value.

¹ Composition of the atmosphere including water vapour.

According to Hann the composition of the atmosphere, including water vapour, is by volume:

	Nitrogen.	Oxygen.	Argon.	Water Vapour.	Carbon Dioxide.
Equator	75·99%	20·44%	0·92%	2·63%	0·02%
Latitude 50° N. .. .	77·32%	20·80%	0·94%	0·92%	0·02%
Latitude 70° N. .. .	77·87%	20·94%	0·94%	0·22%	0·03%

Methods of determining the Height of the Atmosphere.—

There are several methods whereby this value may be determined approximately. (1) By observation of meteoric phenomena. (2) By observation of the duration of twilight. (3) By observation of auroral displays.

The observation of clouds¹ gives the height of the water vapour in the atmosphere, but not necessarily the height of the atmosphere itself. Cirrus clouds have been observed in temperate regions up to heights of 9 to 11 Km., and in Equatorial regions up to 17 Km. There are some records of clouds having been observed at much greater altitudes in tropical regions, and the so-called luminous night clouds were of the order of height of 80 Km. Owing to the nature of the aurora the observation of any particular point by two stations simultaneously presents very great difficulties. Hence the values given for the height of the aurora are very divergent, and it is doubtful if with present methods of observation the values obtained are very useful. There remains therefore the other two methods. The values calculated from meteoric observations lie mainly between 150 and 200 Km., though some calculations would indicate a height of nearly 300 Km. Some of the best results are probably those calculated from the great meteoric showers of 24th December, 1873, and of 18th February, 1912.

In the other method the duration of twilight is noted, and thereby from knowing the radius of the earth and the latitude of the observation point one can calculate the height. Values for lat. 45° give a height of nearly 80 Km. When allowance is made for refraction of the light rays as they pass through layers of air of varying density, this value should be decreased by about 20 per cent, giving thereby a height of approximately 64 Km.

In fig. 5 let the inner circle represent the surface of the earth and the other the upper limit of the atmosphere. SC is a ray of light from the sun. When an observer is at the point A then the sun is on the horizon. When the earth has turned so as to bring him into position B, he is in the limiting position whereby he may receive light reflected from the upper part of the atmosphere. The angle AOB will therefore be a measure of the angle of the "twilight arch", as it is called. From triangle AOC the height of the atmos-

¹This is done by trigonometrical methods, simultaneous observations being carried out at two stations a known distance apart on the same point of a cloud; the same method is applicable in the case of meteors.

phere can then be found; for if R = earth's radius at the particular latitude concerned, and h = height of the atmosphere, then:

$$\begin{aligned}\cos \text{COA} &= R/(R+h) \\ \text{or } R+h &= R \sec \text{COA}, \\ \text{i.e. } h &= R\{\sec \text{COA} - 1\}.\end{aligned}$$

When therefore the angle COA is known, then the value of h can be determined. The figure, however, is drawn on the assumption that the rays of light pass straight through the atmosphere, which

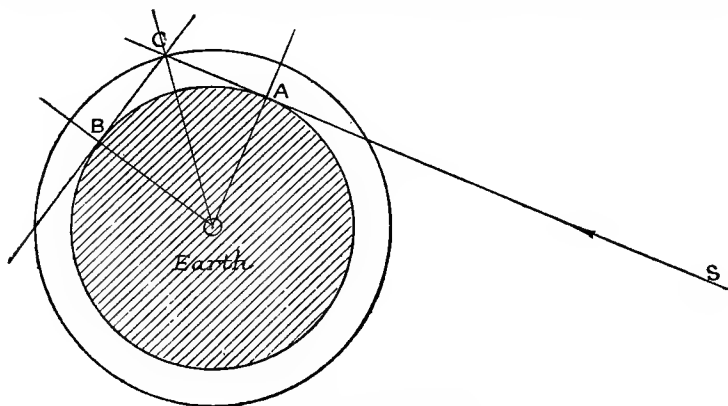

Fig. 5.—Cause of Twilight

is not the case. The method gives a rough approximation only, and when allowance is made for refraction, the value obtained by the figure must be reduced by approximately 20 per cent as stated above.

The Homogeneous Atmosphere.—Though the upper limit of the atmosphere extends far above the surface of the earth, yet half of the atmosphere is contained in a layer 3.6 miles thick. If the whole atmosphere had the same density as it has at the surface of the earth it would extend to a height of only 5 miles above the surface. This height is often called the Height of the Homogeneous Atmosphere, and is commonly denoted by the symbol H .

CHAPTER III

Radiation

The Ether.—In the last chapter we discussed the atmosphere, its constitution, its properties, and the height to which it reaches above the earth's surface. The question naturally arises therefore, what is beyond the atmosphere, what is the medium by which heat and light from the sun and the stars are conveyed to the earth. It has been supposed that all space is filled with a medium called the luminiferous ether which possesses certain properties. The short waves of light and the long electro-magnetic waves of wireless telegraphy are propagated through it at over 186,000 miles per second. It must, therefore, be highly elastic, and as these waves can be propagated in any direction with equal velocity, it must be homogeneous. Light comes to the earth from the farthest depths of space, and therefore this medium must be all-pervading. The planets have moved through it for thousands of years without showing any apparent retardation, the very slight retardation of the earth and consequent lengthening of the day being due to the action of the tides. The ether therefore appears also to be practically frictionless.

Through this apparently frictionless, highly elastic, homogeneous, all-pervading medium is propagated the energy, mainly from the sun, which lights up and warms the surface of the earth.

Radiant Energy.—This energy which arrives at the surface of the earth is in the form of radiant energy, for it passes through the ether without in any way affecting the ether. It is emitted in waves, and the wave length varies over a wide interval. Those waves, whose wave length lies between 300 and 800 millionths of a millimetre, affect our sense of sight, and this portion of radiant energy is called Light. But the radiant energy from the sun extends in wave length both above and below these values. Those rays which have a shorter wave length than the last ray affecting

the sense of vision are known as the ultra-violet rays, and are best detected by their effects on photographic plates, or fluorescent substances. The rays beyond the range of vision at the other end are called the infra-red rays, and can be observed on account of their heating effects. Now, though a body must be at a high temperature in order to radiate energy which will affect the eye, yet bodies which are not heated to a high temperature give out radiant energy, a point which must be borne in mind in treating meteorological problems.

Sources of Energy arriving at the Earth's Surface.—When we examine the various sources from which energy might come to the earth's surface, it soon becomes evident that practically the whole of the energy, which is the prime cause of all meteorological phenomena, comes from the sun. A certain amount of energy comes to the surface from within the earth itself, for as one descends through the earth's crust, it is found that the temperature rises gradually, and therefore a flow of heat must take place from the interior outwards to the surface. This flow of heat, however, must take place nearly uniformly all over the earth's surface, both by day and by night, and therefore cannot account for the daily variation in temperature which actually takes place. Similarly the energy coming from the stars reaches the earth both by day and by night, and the daily variation cannot be explained as being due to this source. There remains therefore the sun as the origin of practically the whole of the energy which causes the variation of the temperature of the atmosphere.

Insolation.—This radiant energy from the sun, or solar radiation, is known as Insolation, and the study of it is called Actinometry. The amount of solar radiation which reaches any particular part of the earth's surface depends: (1) upon the length of time during which the radiation falls upon it; (2) upon the distance of the earth from the sun; for the amount of radiant energy received by a given surface from a hot body is inversely proportional to the square of the distance of the surface from the radiating body. (3) The amount depends upon the directness of the rays; for when a beam of radiation falls upon a surface, then the beam will intercept a larger or a smaller portion of the surface according to the angle of inclination. Let AB be a beam of cross section AB , and let θ be the angle of inclination of the beam to the vertical. Then the portion of the plane intercepted by AB is CD , and $CD = AB \sec \theta$.

Now as θ increases from 0° to 90° , $\sec \theta$ increases from 1 to infinity. Therefore the more directly the rays fall on a surface, the greater the amount that falls on unit area. (See fig. 6.)

(4) The amount depends on the transparency of the atmosphere, and (5) upon the constant of solar radiation.

Case with a Non-absorbing Atmosphere.—Let us suppose in the first place that there is no atmosphere round the earth, or, what amounts to the same thing, that the atmosphere is absolutely transparent to solar radiation, and on this hypothesis consider the distribution of radiant energy reaching the earth from the sun during a year, both as regards latitude and season.

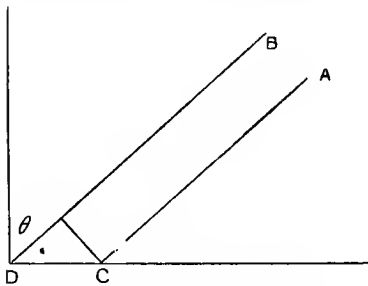

Fig. 6.—Showing Distribution of Radiation.

The Motion of the Earth round the Sun.—The force by which the earth is maintained in its orbit round the sun is inversely proportional to the square of the distance between the two, so that the earth moves not in a circle but in an ellipse, with the sun in one focus. Consequently the distance of the earth from the sun is continually varying. At perihelion on 1st January the distance is 91,340,000 miles, and at aphelion on 1st July the distance is 94,460,000 miles, a difference of 3,120,000 miles. The mean distance is 92,900,000 miles.

Inclination of the Axis of Rotation of the Earth to the Plane of its Orbit.—Further, the earth is not a regular sphere but a spheroid, so that the attraction of the sun does not pass exactly through the centre. The result is, that the plane of the Equator, which is perpendicular to the axis of rotation, is not the plane of the earth's orbit (the ecliptic), the two planes intersecting each other at an angle of 23° . At two points only do these two planes intersect, viz. on 21st March and 23rd September. On these two dates the sun is vertically above the Equator, and day and night are everywhere equal.

Variation of the Duration of Daylight.—If we start on 21st March, when the sun is vertically above the Equator, then, as the sun moves northwards, the day grows gradually longer in the northern hemisphere until 21st June, when he reaches his northern limit, being then vertically above the tropic of Cancer, $23\frac{1}{2}^\circ$

north of the Equator. On this date he does not set on the Arctic Circle, i.e. he is above the horizon for nearly forty-eight hours at that time. At the pole the sun never sets immediately after he crosses the Equator. Here, then, he is above the horizon for a period of six months on end, and within the Arctic Circle, the time he is continuously above the horizon lasts from about forty-eight hours to six months, according to the latitude of the place. On 23rd September the sun is again over the Equator, and as he passes southwards night falls on the Arctic regions, lasting continuously from six months at the pole to nearly forty-eight hours on the Arctic Circle on 20th to 22nd December. At this time the sun is vertically over the tropic of Capricorn, $23\frac{1}{2}^{\circ}$ south of the Equator, and, so far as duration of daylight is concerned, conditions are now exactly the same in the southern hemisphere as they were six months previously in the northern hemisphere. The sun now begins his journey north again, and on 21st March is again over the Equator. Thus as the earth moves in its orbit round the sun, owing to the inclination of its axis of rotation to the plane of its orbit, the length of the day is continually varying everywhere on the surface of the earth, except at the Equator, where it is always a period of twelve hours.

Variation with Time of the Amount of Insolation received in Different Latitudes.—If we regard the constant of solar radiation as known and fixed, then with a non-absorbing atmosphere we have to deal with only two other effects at the Equator, viz. the distance of the sun and the directness of the rays. Consequently, as the sun passes vertically overhead twice in the year at the Equator, there are two maxima in the curve showing the theoretical insolation received by any particular spot on the Equator during the year, one for 21st March, the other for 23rd September. On 1st January, however, the sun is nearer to the earth than on any other day, and as 21st March is nearer the time of perihelion than 23rd September is, the maximum corresponding to the former date is slightly greater than that corresponding to the latter. Yet though the spring maximum is greater than the autumnal maximum, the total amount of energy received by the earth during the two periods is exactly the same. For the period from 21st March to 23rd September is 186 days, while the period 23rd September to 21st March is only 179 days. The effect due to the difference in distance is thus exactly compensated for by the

difference in time. The variation in the amount of solar radiation received at the Equator throughout the year is shown in fig. 7, curve 1.

As we move away from the Equator the two maxima gradually approach one another, becoming one on the line of the tropics. North and south of these two latitudes there exists but one maximum.

As an example of mean latitudes, let us take the case of lat. 45° .

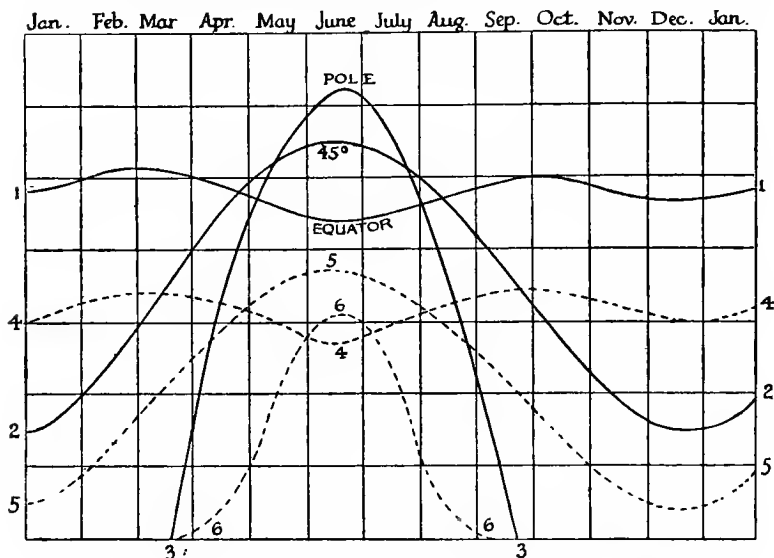

Fig. 7.—The Annual Variation of Solar Radiation at different Latitudes (after Angot)

As the sun moves northwards, the day in the northern hemisphere lengthens from 21st December until 21st June. The daily amount of solar radiation received by one particular place increases regularly for six months, and decreases again during the next six months. The curve showing the variation in the amount received for lat. 45° is curve 2 of fig. 7.

As stated above, the sun does not rise on the Arctic Circle on 21st December, and therefore no solar radiation is received there on that day. Within the Circle, the duration of time in which no solar radiation is received increases until at the pole this time amounts to six months, or, more correctly, lasts from 23rd September to 21st March. During the other half year, 21st March to 23rd

September, the sun is continually above the horizon, and curve 3, fig. 7 shows graphically the amount of solar radiation received at the pole during that period.

In both the last two cases the maximum amount of insolation is received slightly in advance of the summer solstice owing to the variation in the distance of the earth from the sun.

It can be seen from the curves that the amount of insolation which, with our hypothetical atmosphere, would arrive on 21st June at the pole, is greater than that which would arrive at the Equator. When the sun is over the tropic of Cancer his altitude at the Equator is $66^{\circ} 33'$, and the length of the day is twelve hours. At the pole his altitude is only $23^{\circ} 27'$, but he is above the horizon for twenty-four hours, and so the ratio of the two quantities are as 100 to 136.

Insolation received by the Southern Hemisphere.—As regards the southern hemisphere, corresponding results can be obtained by inverting the seasons. There is this fundamental difference, however, that during summer in the southern hemisphere the sun is nearer the earth than he is in winter, which is exactly the opposite of what takes place in the northern hemisphere. On any particular day in summer, then, the amount of insolation received in the southern hemisphere is greater than that received in the northern hemisphere for a corresponding day. Similarly the amount received on any particular day in winter is less in the southern than for a corresponding day in the northern hemisphere. The effect of this is to intensify the difference between summer and winter in the southern hemisphere.

The total amount received by each hemisphere is the same. If, instead of taking a particular day, we consider the periods between 21st March and 23rd September for the northern, and 23rd September and 21st March for the southern hemisphere, we shall find that the total amounts received during these periods is identical, the smaller daily amount being compensated for by the longer duration; similarly for the winter half-year. Thus the total amount of radiant energy received by each hemisphere from the sun throughout the year is identical.

If we take as unit the amount of insolation received on 21st March at the Equator on unit area, the following table gives the variation with latitude of the insolation received on four different dates, and also the total for the whole year. The sun is reckoned

at mean distance. The values for the year are identically equal for latitudes both north and south of the Equator, showing thereby in tabular form that the amount of insolation received by each hemisphere throughout the year is the same.

TABLE V

Latitude.	0°	20°	40°	60°	90°	-90°	
March 21	1.00	0.93	0.76	0.50	0.00	0.00	
June 21	0.88	1.04	1.10	1.09	1.20	0.00	
Sept. 23	0.98	0.94	0.70	0.30	0.00	0.00	
Dec. 21	0.94	0.68	0.35	0.00	0.00	1.28	
Year	$p = 1$	350.3	331.2	276.8	199.2	145.4	145.4
	$p = .6$	170.2	155.1	115.2	67.4	28.4	28.4

Calculated insolation reaching the earth for different dates and latitudes.

The amount of insolation received varies both with time and latitude, and two sets of graphs are necessary to represent these

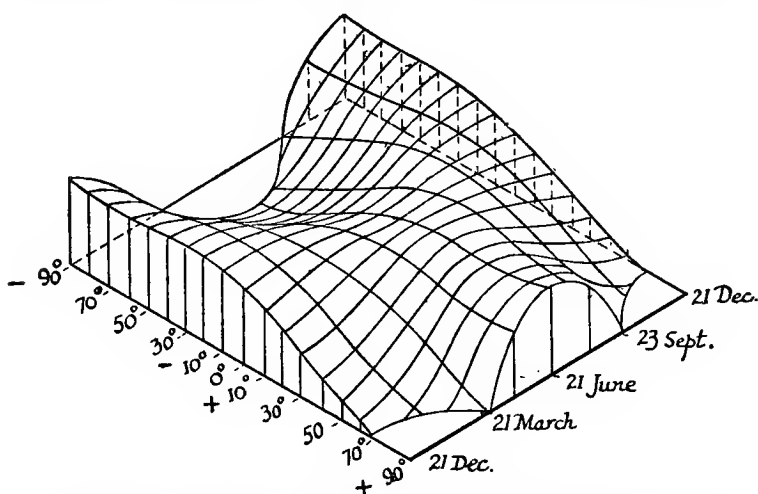

Fig. 8.—Variation in Insolation with Time and Latitude (from Davis's *Elementary Meteorology*)

variations if the curves are all drawn on one plane. In the above figure, taken from Davis's *Elementary Meteorology*, the two sets are combined, and from the figure the value at any time and in any latitude can be determined. Thus, by taking sections on a plane

perpendicular to the plane of the paper and parallel to the line 21st Dec.—21st Dec., we obtain figures of the type shown in fig. 7 by curves 1, 2, and 3. If now the plane be set parallel to the line 90°–90°, then curves of the type of curve 1 in fig. 9 are obtained. On this type of curve the variation in solar radiation with latitude is shown for any particular day of the year, whereas on the other type the variation throughout the year for any one particular latitude is given.

Case with an absorbing Atmosphere.—Hitherto we have considered the case of an atmosphere which transmitted the whole of the radiant energy arriving from the sun, but in reality a certain proportion of this energy is absorbed by the atmosphere, the amount depending upon the mass of air through which the radiation passes. A ray falling normally on the surface passes through a thickness which is equal to the thickness of the atmosphere, and in consequence only a part of the energy which falls normally on the outer surface of the atmosphere reaches the surface.

The Coefficient of Transparency of the Atmosphere.—The fraction of the radiant energy from the sun reaching the surface of the earth is called the Coefficient of Transparency of the Atmosphere, and its value is generally denoted by p . This value is not constant, but differs with the composition of the atmosphere and with the nature of the radiation. When a ray passes obliquely through the atmosphere, the mass of air encountered by the ray is greater than that encountered by a perpendicular ray. But as the air is not of uniform density throughout, the ratio of the two masses encountered is greater than the ratio of the lengths of the two paths, and therefore the absorption increases more rapidly than the length of the path. Thus if l denote the mass of air traversed by the ray, then the ratio of the two values of l , for the sun in the zenith and at an altitude of 40°, is 1/1.56. When the sun is on the horizon this ratio has a value 1/35.5.

Law of Absorption.—Bouguer has given the following law of absorption:¹ “For a given coefficient of transparency, the quantities of solar radiation transmitted decrease in geometrical progression as the amount of atmosphere traversed increases in arithmetical progression”. Expressed symbolically the law is

$$h = Hp^l,$$

¹ Angot: *Traité Élémentaire de Météorologie*, p. 17.

where H = amount of radiation reaching the outer limit of the atmosphere, h = amount arriving at the surface of the earth, the same area being taken in each case, p = coefficient of transparency, and l = mass of air traversed. The following table serves as an example of the application of this law, showing how the amount of radiation reaching unit surface of the earth varies with the altitude of the sun and with the coefficient of transparency. Unit value has been chosen for the sun at an altitude of 90° , and coefficient of transparency equal to unity.

TABLE VI

Altitude of Sun.	Radiation transmitted when Transparency is		
	1	.8	.6
10°	.174	0.050	0.010
30°	.500	0.320	0.181
50°	.766	0.572	0.392
70°	.940	0.741	0.560
90°	1.000	0.800	0.600

Curves analogous to those in fig. 7 can be drawn by the aid of this law by using different values of p . The dotted lines in fig. 7 represent these curves for $p = .75$. The curves are not geometrically similar to the first set on account of the low altitude of the sun in winter and in high latitudes, and consequent greater absorption of radiation. This causes a bigger alteration in the portions of the curves representing these high latitudes and winter months than in the other portions. From curve 6 one can see that the amount of radiation reaching the pole at the summer solstice is greater than that reaching the Equator. If p receive the value 0.6, the annual amount of solar radiation reaching the earth's surface in different latitudes is considerably altered, as shown in Table V.

Variation with Latitude of the Solar Radiation received on one Day.—If instead of taking account of the whole year we consider the curve representing the amount of radiant energy received from the sun during one day, say on 21st June, the effect of this absorption is strikingly shown. On June 21st the sun does not rise on the Antarctic Circle, and therefore for all regions south of that latitude the energy received is zero. As we move northwards this amount increases, and for curve 1, fig. 9, a maximum is reached at lat. 44° N. A slight decrease then takes place up to the

Arctic Circle, but beyond that the curve rises again, finishing with a maximum at the pole. When p is reduced to 0.75 the polar maximum disappears, and there is now only a maximum about lat. 36° N., and only 49 per cent of the energy sent out towards the pole reaches it. If p be given the value 0.50, we have curve 3, fig. 9, showing that only 18 per cent of the energy reaches the pole and that the maximum occurs in lat. 32° N.

A short study of the curves in fig. 9 shows that the amount of solar radiation received during the summer solstice is approximately the same for all latitudes in the northern hemisphere when the value 0.75 is given to the coefficient of transparency, a value which is approximately the mean value. Fig. 7 shows that for the same value of p this equality holds approximately throughout the summer months. In the winter months, however, the case is quite different, the amounts

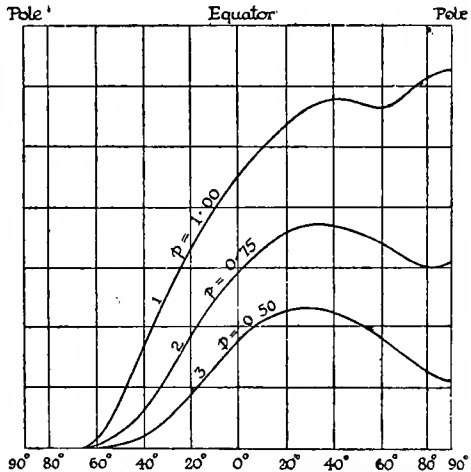

Fig. 9.—Variation with Latitude of Solar Radiation received on 21st June (after Angot)

received differing very considerably. Consequently the variation of temperature with latitude is very much less marked in summer than in winter, a fact which has far-reaching consequences.

Evaluation of "H" and "p".—In order to find the value of H and p in the formula $h = Hp^l$, it is necessary to determine experimentally the amount of radiant energy received at the earth's surface. Many instruments have been invented for this purpose, called pyrheliometers or actinometers. Some of the earlier instruments were Pouillet's Pyrheliometer and Violle's Actinometer. In these instruments a body, whose specific heat is known, is covered with lamp-black and exposed to the direct rays of the sun. Lamp-black is used because its coefficient of absorption is almost equal to unity. When the body has been exposed for some time, then the rise in temperature is noted, and, when allowance has been made for

loss due to radiation, this rise in temperature multiplied by the mass and specific heat of the body gives the amount of heat received in a given time. The altitude of the sun above the horizon at the time of the experiment is known, and thus the mass of air passed through is determined. In this way one relation is established between the quantities in the equation. Another observation is then made and another relation found. These give two equations with two unknowns and therefore H and p can be determined.

Some of the later instruments for measuring radiation are Ångström's Compensating Pyrheliometer, Abbot's Silver-disc Pyrheliometer, and the Callendar Radiograph. At the International Conference of Directors of Meteorological Offices and Observatories held at Innsbruck in 1905, it was resolved to use at all central observatories and at other stations possessing facilities to do so, Ångström's Compensating Pyrheliometer for the measurement of the total solar radiation, the measurements to be made regularly each day at 11 a.m. or from 11 a.m. to 1 p.m. It was also resolved to use this instrument for measurement of terrestrial radiation each day at 11 p.m. or from 10 p.m. to midnight.

Ångström's Compensating Pyrheliometer.—A description of this instrument was communicated by Ångström to the Royal Society of Upsala in 1893¹. In this instrument there are, as calorimetric body, two thin strips of metal identical in every way. One of these is exposed to the sun, while through the other, which is kept in the shade, is passed an electric current, the strength of the current being so adjusted that the temperature of the two strips is the same. The energy of the incident radiation received by the exposed strip is therefore equal to that communicated by the electric current to the strip in the shade. If then a is the coefficient of absorption of the blackened surfaces, b their width, and h the amount of energy radiated per minute per square centimetre, the energy absorbed per unit length = $h \cdot a \cdot b$ calories per minute. Again, if r is the resistance per unit length and i the current, the energy communicated every minute by the current = $\frac{60 ri^2}{4.18}$ calories per minute where r and i are measured in absolute units;

$$\text{i.e. } h \cdot a \cdot b = \frac{60 \cdot r i^2}{4.18}, \quad \text{or} \quad h = \frac{60}{4.18} \cdot \frac{r \cdot i^2}{a \cdot b} \text{ calories per minute.}$$

This method does away with all corrections for cooling.

¹ *Actes de la Société royale des Sciences d'Upsal*, 1893.

In carrying out an experiment the two strips are first exposed to the direct rays of the sun in order to make sure that the direction of the instrument is correct. If the two thermo-couples which are attached to the two strips indicate the same temperature, i.e. if no deflection is shown in the galvanometer to which these couples are attached in opposition, then the direction is correct. One strip is now shaded and a current passed through it, the strength of the current being adjusted until no deflection is recorded by the galvanometer. Then one changes the position of the shading screen and at the same time switches the current through the other strip, adjusting it until a balance is again obtained. One must then change back again to the first arrangement and find the current required to establish a balance. From these readings the mean value of i^2 can be found; r is known when the temperature of the tube is known, and i being known, h can be found.

The Solar Constant.—From two sets of readings whereby h and l are determined experimentally, we have seen that H and p may be found. This assumes that H and p remain constant. With regard to H the assumption is in all probability correct, but with p the case is different. The transparency of the atmosphere varies from day to day, and from hour to hour. The presence of water vapour in the atmosphere makes a considerable difference, and though, during both experiments, the sky may appear perfectly clear, yet there may be present at one time some very thin and very high clouds not discernible to the eye, while at the other time these may be absent. Furthermore, the law holds strictly for radiation of one wave length only, whereas solar radiation consists of a large number of wave lengths, from the long infra-red to the short ultra-violet radiation. Hence the determination of H is a very difficult problem. This quantity H is called the Solar Constant, and may be defined as the amount of radiant energy arriving perpendicularly from the sun on a square centimetre every minute at the limit of the atmosphere. It is measured in calories. As just stated the value of p varies considerably. It is sometimes as high as 0.8, at other times it falls as low as 0.6, and occasionally much lower. With a clear sky the normal value is about 0.75.

Numerical Value of the Solar Constant.—Owing to the difficulty of determining the numerical value of the solar constant, the values hitherto obtained are not in very good agreement. Pouillet found the value 1.76, while Violle has given as the results of his

experiments 2·54. Langley¹, who showed that the values obtained by Pouillet in using the formula $h = Hp'$ were likely to be too small, has given 3 as the value of the solar constant. He was the first to take thoroughly into account selective absorption by the atmosphere, using a diffraction grating to separate out the various wave lengths, and a bolometer to compare the heating effect with different thicknesses of atmosphere passed through.

Crova devised a number of experiments with an actinometer for determining the solar constant, and the results he obtained are even higher than those of Langley, being in the neighbourhood of 4. Probably the best modern results are those obtained by Abbot, Director of the Astrophysical Observatory of the Smithsonian Institute. He gives a value of 1·932 calories.

Effect of Absorption by the Atmosphere of Solar Radiation received during one Day.—This is well shown by the two following figures taken from Hann's *Lehrbuch der Meteorologie*. The heights of the two stations are 2000 m. (Mt. Ventoux), and 40 m. (Montpellier) respectively. The traces show the amount of radiant energy received on a square centimetre surface kept constantly at right angles to the sun during 13th August, 1888. The largest value on Mt. Ventoux is 1·6, on Montpellier 1·2. If there had been no absorption, the graphs would have been identical, and they would have given the value of the solar constant from sunrise to sunset. But instead there is the gradual rise in the morning, the fluctuations during the day as the composition of the atmosphere changed slightly, then the gradual fall at night. It is also worthy of note that the maximum value occurs during the forenoon. As a rule the atmosphere generally becomes less clear during the afternoon, and hence greater absorption ensues.

The Amount of Energy reaching the Earth's Surface from the Sun.—If we calculate the amount of energy coming from the sun that would reach every square centimetre of the earth's surface, on the assumption that the solar constant has the value 2, and that none of the energy is absorbed by the atmosphere, we find that this amounts to about 321,000 calories annually for a point on the Equator. If the coefficient of transparency is reduced to 0·8, then the amount falls to 231,000 calories approximately, while with a coefficient of 0·6 the value is only 156,000 calories. This is the same as saying that the amount of energy reaching the Equator is

¹Langley, *Phil. Mag.*, XVIII, 1884.

such that it would melt annually a layer of ice 141.4 ft., 103.4 ft., or 69.9 ft. thick, according as p the coefficient of transparency has the value 1.0, 0.8, 0.6. The energy reaching the pole is less; there, for the same values of p as above, the thicknesses of ice melted would be 59.4 ft., 27.9 ft., and 11.8 ft. respectively. These values

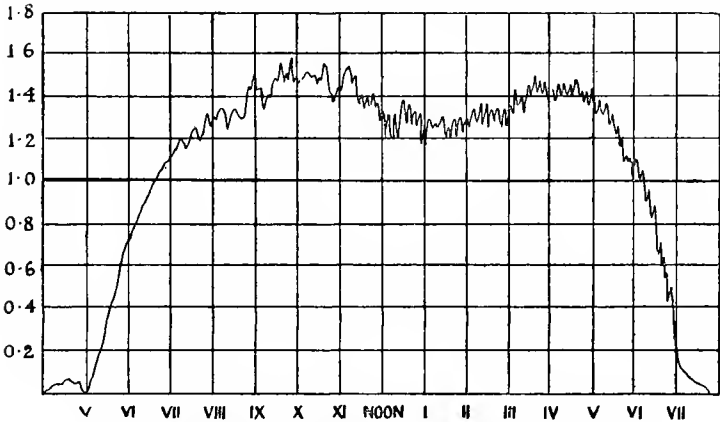

Fig. 10.—Solar Radiation at Mont Ventoux (2000 m.), 13th August, 1888

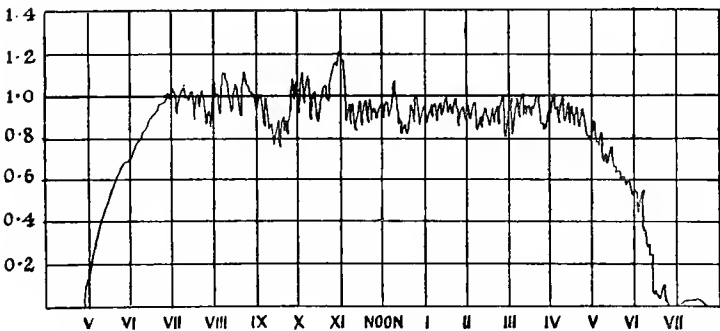

Fig. 11.—Solar Radiation at Montpellier (40 m.), 13th August, 1888
(From Hann's *Lehrbuch der Meteorologie*)

are calculated on the assumption that the sun is never hidden by the clouds. Any attempt therefore to collect and use directly the energy from the sun would give comparatively small results.

To find Relative Values of Solar Radiation.—The instruments mentioned above have been employed to find the absolute value of the solar radiation. Other instruments have been devised to give

the relative value of this quantity. Arago employed two thermometers for this purpose, one being an ordinary thermometer while the other had the bulb covered with lamp-black, and both were hermetically sealed into two glass bulbs exhausted of air. On the two being exposed to the sun's rays, the excess of the reading indicated by the one over that indicated by the other was supposed to give a measure of the solar radiation. This is open to considerable error both on account of absorption of part of the radiation by the glass of the bulbs, which further may not be the same in both cases, and also because it assumes that the ordinary thermometer gives the temperature of the bulb in which the blackened thermometer is. Violle improved on this method by using two metal spheres, the one gilded, the other blackened, with

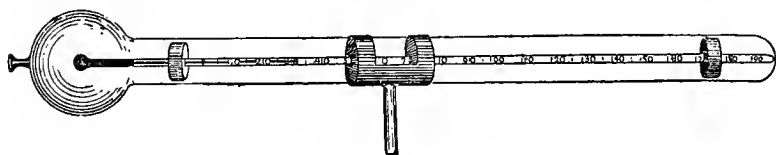

Fig. 12.—Black Bulb in Vacuo

thermometers placed inside. Through noting the differences in temperatures shown by these thermometers and the temperature of the air, he was able to find the relative value of the solar radiation.

The black-bulb thermometer in vacuo has been used as a means of obtaining an indication of the relative value of the solar radiation. It is really a maximum thermometer with the bulb and about one inch of the stem covered with lamp-black. The thermometer is hermetically sealed into a glass bulb which is thoroughly exhausted, and the instrument is placed in the sunlight about 4 ft. above the ground. It is set east and west so that the bulb may be fully exposed to the sun when he is highest. When the energy absorbed by the bulb is equal to that radiated by it, the maximum reading indicated by the instrument takes place. This value is then compared with the reading of a maximum thermometer in the shade. The records, however, are not very satisfactory, for the maximum indicated by the black-bulb thermometer may not take place at the same time as the maximum value indicated by the thermometer in the shade. Also the readings of different instruments are not comparable, and the difference between

two instruments is found by experience not to remain constant. Better results can be obtained by surrounding the instrument with a case at constant temperature.

Actinometers: which depend upon the action of light on photographic paper have also been employed. They may be called chemical actinometers, an example of which is Roscoe's Actinometer. All the instruments referred to above give a measure both of the radiation from the sun and from the sky. By using a Callendar Pyrheliometer and an eclipsing screen this total radiation can be obtained in two components, the direct solar radiation and the radiation from the sky.

Other Radiations.—Birkeland has shown experimentally that effects similar to that of the aurora can be obtained, when cathode rays are discharged in the direction of a sphere magnetized in a manner similar to the earth and then placed in a vacuum. Auroral effects are most frequent during sun-spot periods, and so the sun appears to send out a radiation similar to cathode rays when sun-spots are most active. From a large number of observations of the aurora made in Norway it was found that the bottom edge varied in height above the surface of the earth, being never lower than 85 Km., at other times being much higher. M'Adie¹ therefore suggests that the rays producing the aurora are in two groups with different penetrating power.

In auroral displays we have therefore a type of radiation different from what we have hitherto considered, but its effect on temperature is negligible.

¹M'Adie: *The Principles of Aërography*, p. 278.

CHAPTER IV

Temperature

A.—DETERMINATION OF TEMPERATURE

THERMOMETRY AND THERMOMETERS

On account of the solar radiation the surface of the earth, both land and water, becomes heated and the lower layers of the atmosphere become warmed by radiation from, or direct contact with, the surface. When this takes place the temperature of the air is said to rise.

Temperature Scales.—In meteorology temperatures are measured by means of a mercury thermometer, except in some special instances. Until recently the scales employed in observations have been the Centigrade scale, the Fahrenheit scale, and the Réaumur scale. The absolute scale of temperature, sometimes called the Kelvin scale, is, however, now being used for recording temperatures. In the first three systems the fixed points are the melting-point of ice and the boiling-point of water under standard conditions, i.e. under standard pressure at sea-level in lat. 45°. The zero point in the gas thermometric scale is the absolute zero of temperature or -273.02° on the Centigrade scale.

Relations connecting the different Scales.—The interval between the melting-point of ice and the boiling-point of water is divided in the Centigrade system into 100 divisions, in the Fahrenheit into 180, and in the Réaumur into 80. But whereas in the first and third the melting-point of ice marks the zero of the scale, in the second it corresponds to 32 on the scale, the boiling-point of water being represented by 212. Thus if C, F, and R represent the values in the different systems, they are found to be connected by the following equations:

$$\frac{C}{100} = \frac{F - 32}{180} = \frac{R}{80}$$

If A denotes the temperature on the absolute scale, then

$$C = A - 273.$$

All air temperatures are in reality temperatures on the hydrogen gas thermometric scale, but in the interval 0° C. to 100° C. these differ but little, always less than $\frac{1}{10}$ of a degree, from the temperatures of a mercury thermometer, and therefore the latter can be used without any appreciable error for all ordinary temperatures met with in meteorology. If another substance, e.g. alcohol, be used, the thermometer must be compared with a mercury thermometer, and the scale divided accordingly.

On the continent of Europe the centigrade scale is in general use, whereas in English-speaking countries the scale in use is the Fahrenheit. This has led to a considerable amount of trouble in converting from the one system to the other, and, further, both must be converted into the absolute scale when any problem dealing with the air, such as the buoyancy of balloons, has to be solved. Consequently the absolute scale is now being introduced in the measurement of temperature. This scale has also the advantage that on it there are no negative values, for the zero is the absolute zero of temperature, the melting-point of ice 273° A., and the boiling-point of water 373° A., under the same conditions as mentioned above. The Réaumur scale is not used at the present day for scientific purposes.

The Thermometer: its development.—Temperatures, as stated above, are measured by means of a thermometer. In Chapter I a brief account was given of the invention of the thermometer in the time of Galileo. For about a hundred years after his time various liquids were tried with but little success until, in 1714, the Fahrenheit thermometer was produced in Danzig.

The Fahrenheit Thermometer.—The two great improvements introduced by Fahrenheit were (1) the use of mercury as a liquid, and (2) the fixing of the two points—the melting-point of ice, and the boiling-point of water. It is not certain why he chose 32 as the temperature of melting ice, unless perhaps he regarded the temperature obtainable by a mixture of ice and salt as the lowest possible, and on dividing the interval between the melting-point of ice and the boiling-point of water into 180 divisions, found that the interval between the melting-point of ice and his zero formed 32 of his

divisions. His reason for dividing the interval between the two fixed points into 180 arose probably on account of the dividing machine he used.

The Centigrade Thermometer.—In 1742 another thermometer was produced by Celsius at Upsala. In this type the interval between the melting-point of ice and the boiling-point of water was divided into 100 divisions, the boiling-point of water being zero and the melting-point 100. Later the values were inverted on the scale by Linnæus, giving the centigrade thermometer as it is known at the present day.

The Réaumur Thermometer.—The Réaumur thermometer, invented in 1731 by Réaumur, a French physicist, has the interval between the two fixed points divided into 80 divisions. It is still used popularly in Russia, but is not employed for scientific purposes.

Essentials of a Thermometer for use in Meteorology.—1. The temperatures met with in meteorology seldom exceed 100° or fall below the zero of the Fahrenheit scale in temperate regions, though the limits are rather wider when tropical and Arctic regions are included. Still, the highest temperature ever recorded was 127° F., and the lowest -90° F. For the temperate zone, therefore, a thermometer graduated from -10° F. to $+130^{\circ}$ F. will be sufficient. In this interval there falls only the one fixed point, the melting-point of ice. Such thermometers, therefore, must be graduated by comparison with a standard. If a centigrade thermometer be used, a range from -25° C. to $+55^{\circ}$ C. will be sufficient for most purposes, which on the absolute scale is equivalent to -248° A. to 328° A. As the glass of a thermometer is subject to change with time, thermometers should be tested regularly at least once a year. Any error found can then be allowed for, and the correct value recorded. If the glass used in making the thermometer be maintained at a temperature above 400° C. for a considerable time, it is found that very little alteration takes place in the glass with time.

2. Next, a thermometer must be sensitive, i.e. it must adjust itself very quickly to the temperature of the air in which it is. For this purpose the mass must be as small as possible and the surface exposed as large as possible. A thermometer with a long, narrow, cylindrical bulb is therefore best suited.

3. The liquid used must not freeze at ordinary temperatures, nor boil at moderately high temperatures. Neither must it be decomposed by the action of light. For ordinary temperatures, therefore,

mercury is used, but, as it freezes at -39° C. (234° A.), alcohol is used for low temperatures.

4. The graduations should be marked on the stem of the thermometer. If the graduations be marked on the backing to which the thermometer is fixed, the latter may shift, and the readings then given would be false.

5. The bore in the stem should be uniform.

Errors to be avoided when using a Thermometer.—1. The first error to be avoided is the use of a bad thermometer. A bad thermometer is worse than no thermometer, as it may give entirely false and misleading values. 2. Having obtained a good thermometer, the observer must now be careful to avoid the error of parallax in reading. The eye must always be brought on a level with the end of the liquid column in the stem, otherwise an error of as much as one degree may be made either in the one direction or in the other in reading. 3. The observation should be made as quickly as possible so that the thermometer may not be affected by the proximity of the observer. 4. If a thermometer be shifted from one place to another, where there is a considerable difference of temperature between the two points, time should be given for the instrument to take up the temperature of its new surroundings. Not less than five minutes should elapse before a reading is taken. 5. Care should be taken not to strain a thermometer by subjecting it suddenly to large differences of temperature, which may result in a permanent error being produced.

Besides these errors mentioned, there may arise permanent errors due to gradual change in the state of the glass. Hence it is necessary that the instrument be tested regularly so that any permanent error arising in this way be detected and allowed for. A slight alteration takes place with change of pressure, but as this difference only amounts to about one-half degree centigrade when the temperature is observed first in the air and then in a vacuum, the ordinary barometric changes will have but little effect, and can be neglected so far as meteorology is concerned.

The true Air Temperature.—The glass of the thermometer allows the light rays of solar radiation to pass easily through it, but not the longer heat rays. Consequently the light rays are absorbed by the bulb; but it cannot again radiate out this energy except by conduction, and as air is an exceedingly bad conductor, the heat will escape only very slowly. The result is that the temperature

of the bulb, if it be exposed to the direct rays of the sun, will rise very much above the temperature of the surrounding air. At night time it will radiate out more quickly to the sky, especially if the night be clear, than it can receive radiation from the earth and the air, and therefore it will indicate a lower temperature than the real air temperature. An approximation to the real temperature can be got by placing a thermometer under a tree or in a shelter on a wall facing northwards. Care must be taken, however, that the wall itself is not heated, otherwise entirely false values will be obtained. This method enables moderately-accurate values to be got on most occasions, though at times they may be in error by as much as 2 or 3 degrees. To obtain the real temperature of the air, therefore, is not an easy matter, and to overcome the difficulty, meteorologists have devised the following methods: (1) by a sling thermometer; (2) by an aspiration thermometer; (3) by means of a thermometer shelter.

METHODS OF OBSERVATION

Let us consider now these three methods of obtaining the real air temperature.

The Sling Thermometer Method.—The first of these is the sling thermometer method. In the instrument used, two thermometers are attached to a base and the whole attached to a chain and handle, so that the thermometers may be swung round rapidly. In some cases the bulbs are protected by wire netting to prevent injury. By whirling, the thermometers are brought into contact with a much larger quantity of air than they would be otherwise, and consequently they lose much more heat by conduction. Therefore the radiant energy absorbed no longer accumulates, and the real air temperature can be obtained to within half a degree under any conditions, even in bright sunshine, if the temperature be read sufficiently quickly. Slight errors arise owing to lowering of the mercury column by centrifugal force and the slight warming of the bulb due to the friction of the air. These tend to counter-balance each other, however, and the total result is negligible. Care must be taken that the bulb is perfectly dry, otherwise too low values will be obtained.

The Second Method or the Ventilation Thermometer Method.—The true air temperature can be obtained by means of an aspiration thermometer or Assmann Psychrometer. This instrument,

as its name implies, was invented by Assmann of Berlin in 1887, and affords the best method yet adopted of determining the real air temperature. As the result of a large number of trials, it is found that the instrument will record the temperature to within $\frac{1}{10}^{\circ}$ F. under any conditions whatever. The instrument is represented in fig. 13, and consists essentially of two thermometers fixed rigidly in a framework. This framework is covered with burnished silver, which reflects 90 per cent of the insolation. The stems of the two thermometers, T, T, are protected by silvered shields S, S, while the bulbs are enclosed in double jackets J, J. These jackets are separated from the stem shields by means of ivory rings R, R, to prevent any heat from the rest of the instrument reaching the jackets. The air is drawn past the bulbs by means of the fan F, and the direction of the air path is indicated by the arrows in the diagram. Some of the air current passes between the two walls of the jackets, and so any heat that may be absorbed on the outer wall is carried away by this current. It is an exceedingly portable instrument, and easily affords the best method of determining the air temperature under any conditions whatsoever. Its value in determining the relative humidity of the atmosphere will be referred to in a later chapter.

Thermometer Shelter Method. — This method of determining the real air temperature is the method most generally in use at fixed observation stations. The type of thermometer shelter differs according to the latitude in which it is used. The type in use in the British Isles is the Stevenson screen.

The Stevenson Screen. — This consists of a cubical box with double louvred sides. The roof is double, the under part being horizontal, with a number of holes 1 in. in diameter drilled in it. The upper part of the roof has no holes, and slopes slightly from the front to the back of the screen, being $1\frac{1}{2}$ in. above the under roof at the front and $\frac{1}{2}$ in. above it at the back. The bottom consists of half-inch boards, three in number, 4 in. wide, and

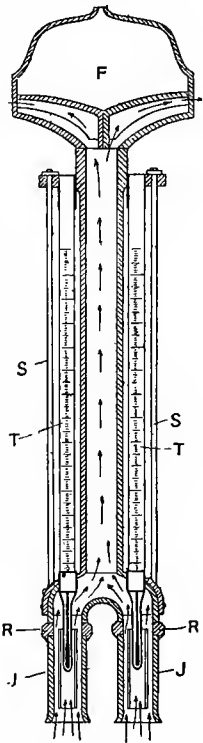

Fig. 13.—Assmann's Ventilation Thermometer

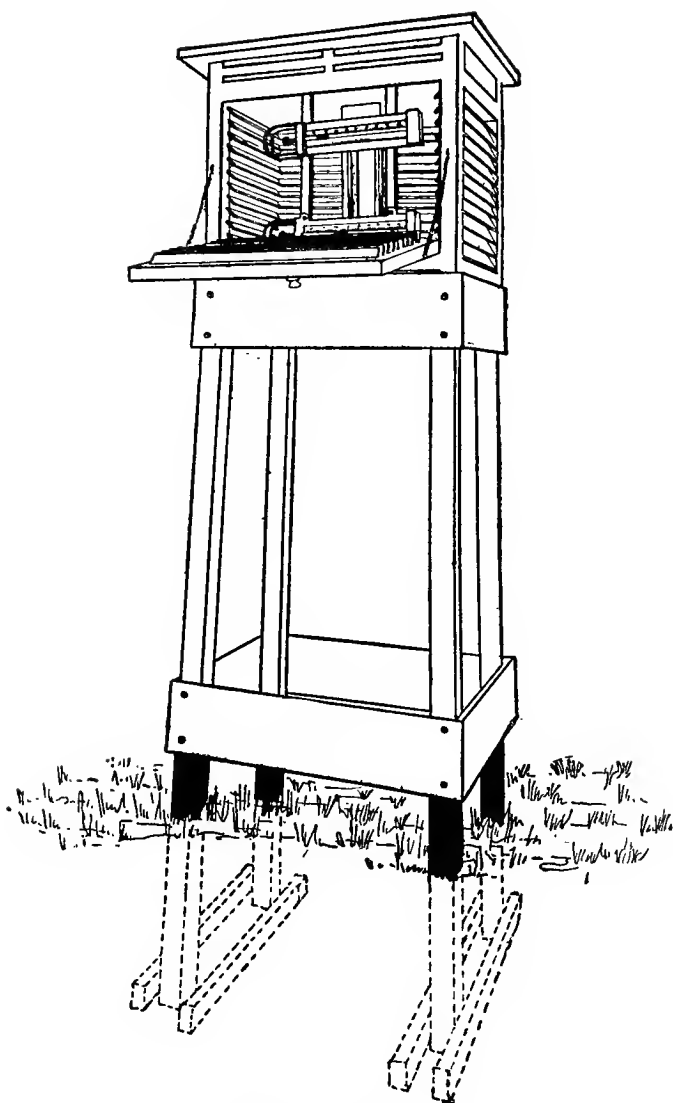

Fig. 14.—The Stevenson Screen

arranged so that the centre one is 1 in. above the outside two, and overlaps them by $\frac{1}{2}$ in. The internal dimensions of the screen are, length 18 in., width 11 in., and height 15 in.¹ The object

¹ For particulars regarding the construction of the screen the reader is referred to *The Observer's Handbook of the Meteorological Office*, London, p. 124, 1918 edition.

of the double roof is to shield the thermometer from the solar radiation. The top part absorbs the insolation, and the circulation of the air between the two prevents the air inside from becoming heated. The louvred sides permit of free circulation of air through the screen, and the boards on the bottom prevent radiation from the earth reaching the thermometers, while the openings between them allow the air to circulate freely. The screen should be placed over short grass, with the bottom $3\frac{1}{2}$ ft. above the ground, and with the opening side towards the north. It must be placed in the open away from the shelter of trees and houses. In a city, if no open space is available, the roof of a house is the most suitable place. This will not give the temperature down on the streets, but by experiment it has been shown to approximate closely to the temperature of the air in the surrounding country. When the air is very still, as on a hot summer's day, the temperature recorded in such a screen is apt to be too low, while on a still cold night it is apt to be too high. The screen is represented in fig. 14.

Other Thermometer Shelters.—The shelter used in America is very similar to the Stevenson screen. In southern Europe, e.g. in Italy, a single louvred screen is used, as a screen with double louvres would not permit of sufficient ventilation. In the tropics, thermometers are exposed in a wire cage which is suspended under a perforated thatched roof. Still, though the details of the shelter vary from country to country, the principle underlying is the same in each case.

Thermometers in the Shelter.—In the Stevenson screen are fitted four thermometers. Two of these are ordinary thermometers, the only difference between them being that the bulb of the one is kept moist, the reason for which will be seen later on. The other thermometer indicates the temperature of the air at the time. The type of thermometer used is shown in fig. 15. These two thermometers are placed vertically in the screen.

Besides these two, the screen contains also a maximum thermometer and a minimum thermometer. Both are placed horizontally

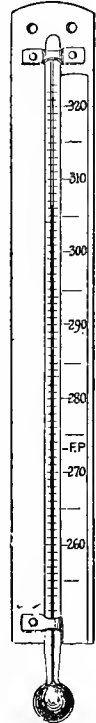

Fig. 15—Ordinary Thermometer (in degrees "absolute")

when in action. The liquid in the former is mercury and in the latter alcohol.

The Maximum Thermometer.—When the temperature rises the mercury in the bulb of this thermometer expands into the stem; but near the bulb there is a constriction¹ in the stem, which, on the mercury contracting through the fall of temperature, causes the mercury thread in the stem to break. The column within the stem, therefore, remains at the highest point reached during the

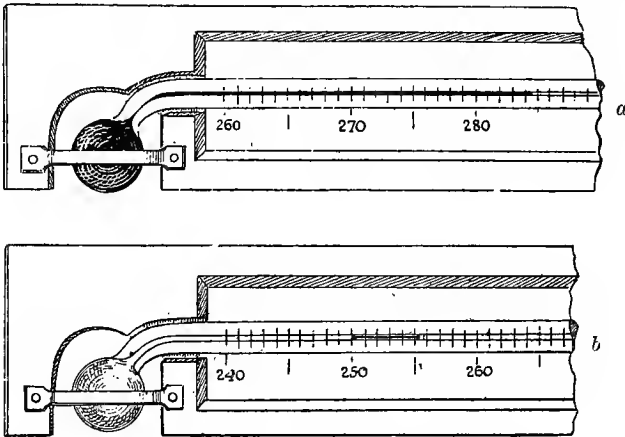

Fig. 16.—Details of Maximum (a) and Minimum (b) Thermometers

period which has elapsed from the time of last setting. In order to obtain the maximum temperature during every twenty-four hours, the thermometer must be set regularly each day at the same time. This is done by giving the instrument a sharp swing, when the mercury flows through the constriction into the bulb.

The Minimum Thermometer.—As already stated the liquid² in this instrument is alcohol. Within the liquid is a small dumb-bell index. As the temperature falls the liquid contracts, and by reason of the surface tension the meniscus of the liquid pulls the index back with it. When the temperature rises again the index is left

¹ The constriction in the stem of the maximum thermometer may become widened in course of time, causing the instrument to behave as an ordinary thermometer, and rendering it useless as a maximum thermometer.

² The liquid in the minimum thermometer occasionally distils into the part of the stem remote from the bulb. When this takes place this liquid must first be made to join the main body of the liquid by swinging the thermometer before the thermometer is set.

Observers ought to watch carefully for such cases, otherwise entirely false readings may be obtained.

at the lowest value reached, the liquid flowing past it. Like the maximum thermometer, it must be set regularly, and this is done by tilting the bulb and allowing the index to slide down until it reaches the meniscus. The two thermometers are shown in fig. 16.

Other Thermometers.—A thermometer which combines the functions of the last two thermometers is Six's Maximum and Minimum thermometer. It is shown diagrammatically in fig. 17. The portions AB and CD are filled with alcohol, the portion BC with mercury, while above A in the bulb is air. There are two indexes, consisting each of a piece of steel wire surrounded by glass. To the ends are attached small feather-like springs as shown in the diagram. When the temperature rises, the alcohol in CD expands, forcing down the mercury, which in its turn pushes up the index above B and compresses the air in the bulb A. When the temperature falls the liquid contracts, and the compressed air causes the mercury column to move in the opposite direction, pushing before it the index above C. These two are therefore brought to the positions of the highest and lowest temperature, and the small spring appendages prevent them from slipping down when the mercury column moves away and the alcohol flows past them. The instrument is set by means of a steel magnet, whereby the indexes are brought to the two ends of the mercury column, the steel within the index being attracted by the magnet.

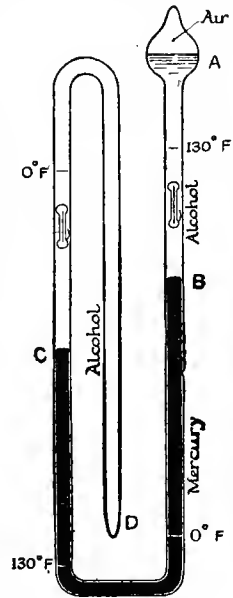

Fig. 17.—The Principles of Six's Thermometer

The solar radiation thermometer, or Black Bulb in vacuo, has already been described in Chapter III.

The Terrestrial Radiation or Grass Minimum Thermometer.—This is an alcohol thermometer. It is not set on a wooden mounting like the ordinary minimum, but has the stem surrounded with a glass tube to prevent distillation of the liquid and to protect the glass scale from wet when in use. It is exposed on two wooden supports over short grass, an inch or two above the ground. When snow is on the ground it should be placed as close to the snow as possible, but *not* touching it.

The Earth Thermometer.—To find the temperature at various depths in the earth, various devices may be employed. One method is to employ a thermo-junction, but perhaps the simplest way is to use an earth thermometer. The thermometer is fixed on a frame which slides into an iron tube fixed in the ground. The thermometer itself is placed in a glass tube and the bulb is surrounded by paraffin wax. To read the instrument, the thermometer is raised level with the eye to avoid the error of parallax and the value noted as quickly as possible, care being taken that the bulb is not exposed to the direct rays of the sun. The depths for which temperatures are taken are usually 1 ft. and 4 ft.

The Telethermometer.—This instrument is shown in fig. 18. By means of it the temperature outside a building can be recorded inside. This type of thermometer is used in observatories to obtain a continuous record of temperature. At

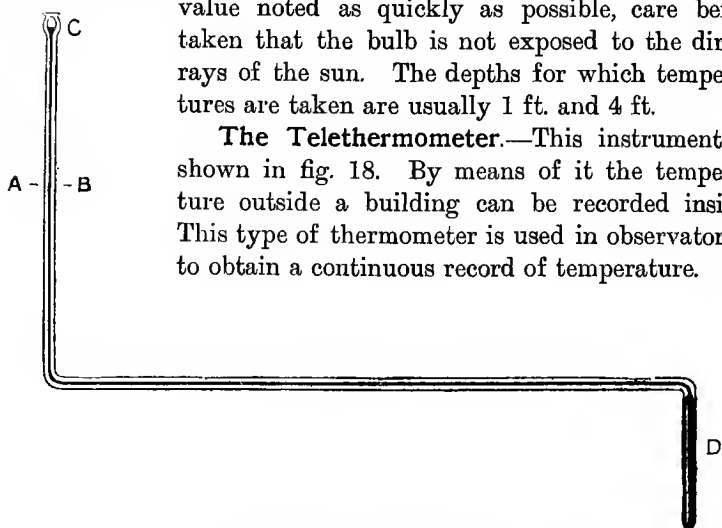

Fig. 18.—The Telethermometer

C is a small reservoir to receive the excess of mercury. D is the long cylindrical bulb which is placed outside the building.

AB, fig. 18, there is a short break in the mercury column. If then a beam of light be allowed to pass through this and be focused on a revolving drum covered with sensitive paper, a continuous record of the temperature is got. Such an arrangement is therefore a thermograph.

The Thermograph.—In the ordinary thermograph the thermometer consists either of a Bourdon tube, the curvature of which changes with the alteration of the air temperature, or of a bi-metallic spiral which coils or uncoils with the change in temperature. One end of the thermometer is rigidly fixed to the frame of the instrument, while to the other is connected a recording pen either directly or by means of a system of levers. This pen traces a

record of the temperature on a revolving drum. In the pattern issued by the M.O., London, which is a bi-metallic spiral thermograph (see fig. 19), either a daily or a weekly clock drum is used, giving thereby a daily or a weekly chart as required. The position of the pen on the chart can be altered, enabling the instrument to be set for different latitudes and different seasons. In the British Isles, two sets of charts are used, one for winter with a temperature

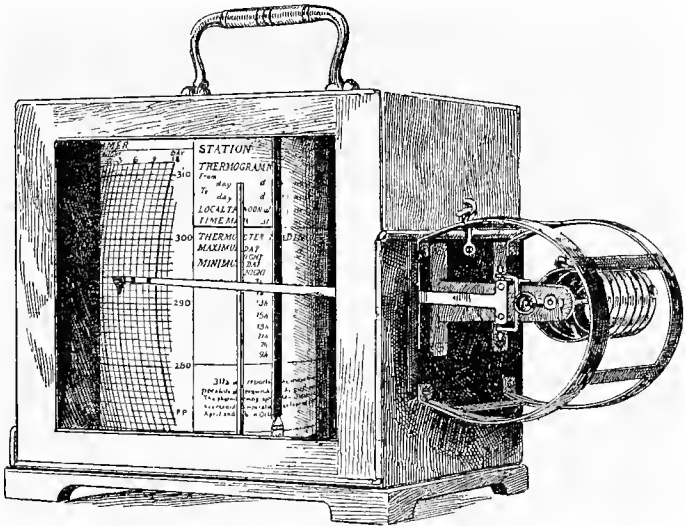

Fig. 19.—Thermograph

range from -10° F. (250° A.) to $+65^{\circ}$ F. (291° A.), and one for summer, ranging from 30° F. (272° A.) to 105° F. (314° A.). The exact time for changing from the one set to the other depends on the locality, but approximate times are during the months of April and October.

Though the thermograph gives a continuous record of the temperature variations, it does not dispense with the eye readings entirely. The latter should be taken at regular intervals every day, and the thermograph should always be adjusted by the aid of these readings. The great advantage of the thermograph is that it enables the eye readings to be considerably reduced, so that instead of 24 hourly readings every day, three readings spread across the same period are found to be sufficient. Further, the continuous

record enables variations to be shown which would escape notice even with 24 hourly readings each day.

Exposure of Thermograph.—The thermograph should be exposed in a Stevenson or similar screen, along with a maximum and a minimum thermometer. These should be set at regular intervals, and a mark made on the trace at the time of setting, so that the continuous record may be checked. If the maximum or minimum value as shown by the trace be of very short duration, there may be a considerable difference between the value given by the trace and that by the control thermometer, owing to the sluggishness of the latter.

Other Thermographs.—The Richard Frères thermograph, manufactured by Richard Frères, Paris, is similar to the M.O. pattern. It is used in France, and also in the United States of America. In America the Draper thermograph is also used. All three have a bi-metallic thermometer.

THE RESULTS OF OBSERVATION

The Diurnal Variation of Temperature.—A few observations are sufficient to show that there takes place a diurnal variation of temperature, an increase during the morning and early afternoon, then a decrease during the late afternoon and night. On a day on which the meteorological elements are normal this variation is very regular, the curve rising regularly and falling regularly as in fig. 1, p. 16. On other days, however, that regularity is largely masked by various effects and the curve becomes irregular, see fig. 2, p. 17. Therefore, in order to investigate the law of the diurnal variation of temperature, it is necessary to study the hourly means over a period of say a month. In this way one is able to get rid of influences peculiar to any one day in the period, and the result is a fairly smooth curve. If, instead of considering only one year, the values be found for any one month over a period of thirty or forty years, then it is possible from the curve to recognize the law governing the diurnal variation.

The Law of the Diurnal Temperature Variation.—Soon after the sun rises, the temperature begins to rise and continues to do so until about 14 h. Then it begins to fall, the fall continuing during the night and until just after the sun rises again, when the minimum is reached. The diurnal temperature variation is then in

most regions a regular periodic variation, the period being 24 hours.

The Reason for the Periodic Variation.—The reason for this periodic variation is easily explained. As the sun rises above the horizon, the amount of radiant energy received by the earth gradually becomes greater than the amount radiated out from the earth. So long as this continues, temperature rises, and as even after the time when the sun is highest, the amount of radiation received continues to be greater than that radiated out to space, the rise continues until equilibrium is reached. After this the amount radiated out is greater than the amount received, and consequently the temperature falls, and continues to do so until after the rising of the sun next day, when a balance is again reached, following which temperature rises again. This explains also why the minimum falls a little *after* the rising of the sun.

Fig. 20 represents the diurnal variation of temperature at Aberdeen and Kew for the months of January and July.

It can be seen that the maximum for the day in both months falls about 2 p.m.

On the other hand the time of minimum varies with the time of sunrise. Thus, in July it occurs about 4 a.m. at both stations, i.e. soon after the rising of the sun. In January the behaviour at the two stations is slightly different. At Kew, the minimum falls about 8 a.m., or approximately at the time of sunrise, whereas, at Aberdeen, the temperature is nearly constant from 2 a.m. until 8 a.m., the difference between the extreme values in that period being less than 0.1° A., and the absolute minimum falling at 6 a.m. By 9 a.m. the temperature has risen slightly, showing the effect of the solar radiation. As the station is situated on the coast, the temperature is not likely to fall on the average below a certain value determined by the sea temperature, and hence the uniformity of temperature during the early hours of the morning. In July, as the land is warmer than the sea, this uniformity of temperature is not likely to be shown, as even at the minimum value it has not fallen below the sea temperature.

The Amplitude of the Diurnal Variation.—The amplitude of the diurnal variation can easily be found from these curves. The values for Aberdeen are 1.5° A. for January, 4.1° A. for July, and for the whole year 3.04° A. Kew on account of its more inland situation shows an increase on these values, the amounts for that station being 2.4° A., 7.5° A., and 5.24° A. respectively. Another

method of obtaining this amplitude is to take the absolute maximum and minimum values as registered by maximum and minimum thermometers. The values so obtained are always greater, as no attention is paid to the exact hour at which these values occur. By this method the values for Aberdeen are 3.5° A. for January,

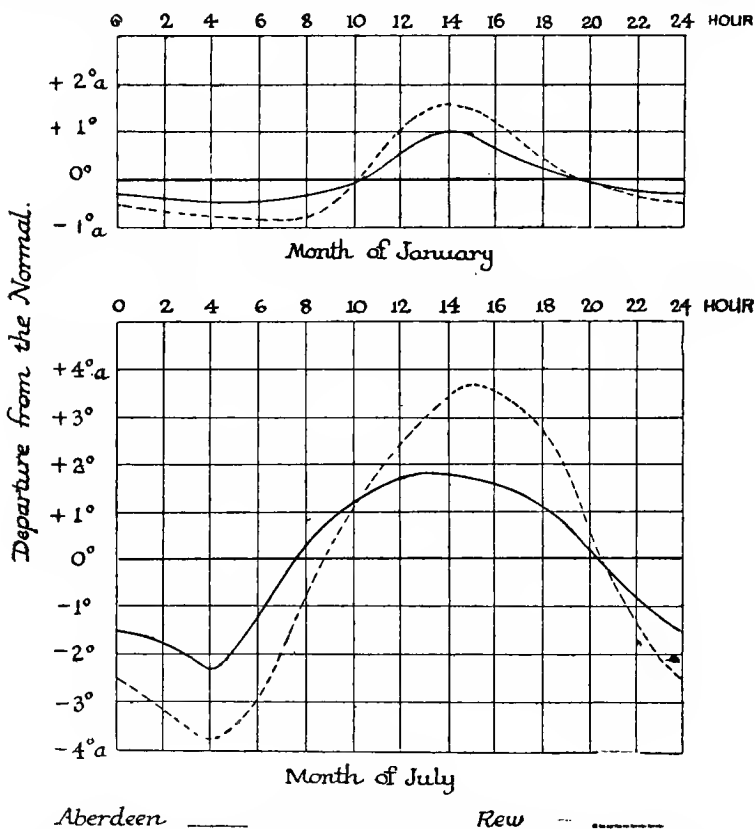

Fig. 20.—Diurnal Variation of Temperature at Aberdeen and Kew for January and July for the period of 1871-1910

6.7° A. for July, and 5.5° A. for the whole year, values which show a marked increase on the others. Unless otherwise stated, however, this is the method adopted for calculating the diurnal range of temperature both on account of its simplicity, and further because the number of stations where continuous records are kept is comparatively small. These hourly mean-value curves are further useful in enabling one to determine at what hours daily observations

should be made in order that the mean of these few observations may approximate as closely as possible to the mean of the 24 observations. Thus, if observations are made at 7 h., 13 h., and 21 h., or at 9 h. and 21 h., it is found that the mean temperature as deduced from these observations does not differ greatly from the mean of the 24 hourly values.

Effect of Latitude and Season on the Diurnal Temperature Variation.—The air in contact with the ground becomes warmed not directly by the sun's rays, but partly by radiation from the earth and partly by contact with it. Part of the solar radiation, as we saw in Chapter III, is absorbed by the atmosphere, but this absorption takes place mainly in the upper reaches of the atmosphere. Near the ground it passes almost unaffected through the air unless much water vapour is present. The surface of the earth becomes warmed by this radiation, and it in turn radiates, but its radiation is of much longer wave length and can thus be much more readily absorbed by the atmosphere. The variation in temperature therefore depends on the original amount of heat coming from the sun. At the Equator the amount of heat coming from the sun varies but little from one season to another; and further, day and night are continually equal, so that the diurnal variation remains practically constant. In temperate latitudes, the variation with the season is considerable. In January, the amplitude of the variation at Aberdeen was 3.5° A., and in July 6.7° A. If we take a more inland station, e.g. Eskdalemuir, this variation with the season is much more marked, the values there being 3.7° A. and 10.3° A. respectively. This difference in amplitude is due to the different amounts of heat received from the sun in the different seasons. Thus, in summer the warming of the earth is considerable during the day, and as the amount of heat radiated out by a body depends on its temperature, the cooling at night is more rapid. Consequently, the amplitude of the diurnal variation is considerable. In winter, on the other hand, the amount of solar radiation received in this latitude is much smaller, the warming of the surface of the earth is less, and the cooling at night is in consequence slower.

When we pass within the Arctic Circle, conditions become different. There the sun is below the horizon continuously for a period varying from about 48 hours to 6 months according to the latitude. When that is the case, there is no diurnal variation. As the sun moves northwards in the spring, the diurnal variation

begins, the maximum occurring at about 14 h. as in other latitudes. The minimum falls earlier and earlier in the morning as the summer approaches, until, when the sun is above the horizon continuously, the minimum value occurs between 1 h. and 2 h., i.e. a short time after the sun has been at his lowest point above the horizon. At the pole itself diurnal variation in the 24-hour sense does not exist. If one considers the day as lasting 6 months, then at the pole the diurnal and annual variations become the same. With the day as 24 hours, however, the diurnal variation increases from zero at the poles and becomes a maximum near the Equator.

If then the atmosphere were perfectly transparent to solar radiation, or if the same proportion were transmitted continuously, the curve showing the diurnal temperature variation would be a regular curve with a maximum about 14 h. and a minimum just after the sun rose. This would hold for all seasons in the tropical and temperate zones. In the polar zones it would hold for all latitudes and all seasons during which the sun was above the horizon at any time during the 24 hours, except for the poles themselves. There, as stated above, the period is only annual, the maximum occurring during the summer six months and the minimum during the winter period.

Other Causes affecting the Diurnal Temperature Variation:
CLOUDS.—There are several causes affecting the diurnal variation, making it become irregular. If the sky become overcast with clouds, then the amount of heat received by the earth's surface is greatly diminished. On the other hand an overcast sky at night prevents radiation, and the result is that the amplitude of the diurnal variation is greatly reduced, or in other words, the curve representing it becomes flatter.

SITUATION.—Another influence to be considered is the situation of a station. If we consider two stations, one on an island in the ocean, the other in the centre of a large continental area, then these two stations present considerable differences. In the neighbourhood of the former there is much water vapour in the atmosphere which tends to absorb much of the solar radiation. Further, the radiation that penetrates to the surface of the ocean is expended not only in warming the water but also in changing its physical condition. Part of the water goes into vapour without any change in temperature. In this process a considerable amount of energy is used up. Also, the specific heat of water is much greater than that of soil so

that the same amount of heat would not cause the same rise in temperature in the two cases. Also, whereas the daily effect of the solar radiation penetrates the land only a short distance, the surface of the sea is continually in motion, and therefore a greater amount of surface is exposed and the energy is carried to a greater depth. From all these causes, the rise in temperature during the day at an island station is very much less than that at a continental one; and many of the causes which prevent rise in temperature during the day, prevent radiation at night. For stations on the same parallel of latitude, therefore, the amplitude of the diurnal variation depends on their situation with regard to sea and land. An example of this is afforded from Cape Caxine to the north-west of Algiers and Biskra at the entrance of the Sahara. At the former the variation in January is 5.2° A., in August 6.6° A., while at the latter it is 11.3° A. in December and 17.6° A. in August.

VEGETATION.—Another cause affecting the diurnal variation is the difference in vegetation. Where the vegetation is rich, the variation is much smaller than in a dry, barren region. In the latter all the energy goes to warm the barren surface of the earth, and, as the air is very dry, there is nothing to prevent radiation at night. In the former much of the energy is absorbed by the vegetation, and the moisture in the atmosphere arising from the vegetation prevents radiation at night.

VALLEYS.—Valleys also play an important part. A station situated in a valley will have a bigger diurnal variation than a station on a plain, even though the two be exactly of the same altitude and in the same latitude. The cold air drains down into the valley at night from the mountain sides, thus causing a greater lowering of the temperature than on the plains, whereas in the daytime the reflection of the sun's rays from the sides of the mountains tends to warm up the air more than on the open plain. Any place therefore which is of a concave nature shows a much bigger diurnal variation of temperature than one that is convex in form.

Effect of Height above the Surface on the Diurnal Temperature Variation.—As the air is nearly transparent to solar radiation, it is but slightly warmed by the radiation passing through it. In consequence we should expect the diurnal variation in temperature to become smaller as we ascend in the free atmosphere. The best example of this is shown by the results obtained from the station on the Eiffel Tower, 302 m. above the ground. There

the amplitude in January is only 1.2° A. and in July 5.4° A., whereas at Parc St. Maur, 2 m. above the ground, the values are 3.3° A. and 9.3° A. for January and July respectively. Also the times of maximum and minimum are later than at the surface. The results are shown in fig. 21. The same thing takes place to a certain extent at mountain stations. The mass of the mountain exercises

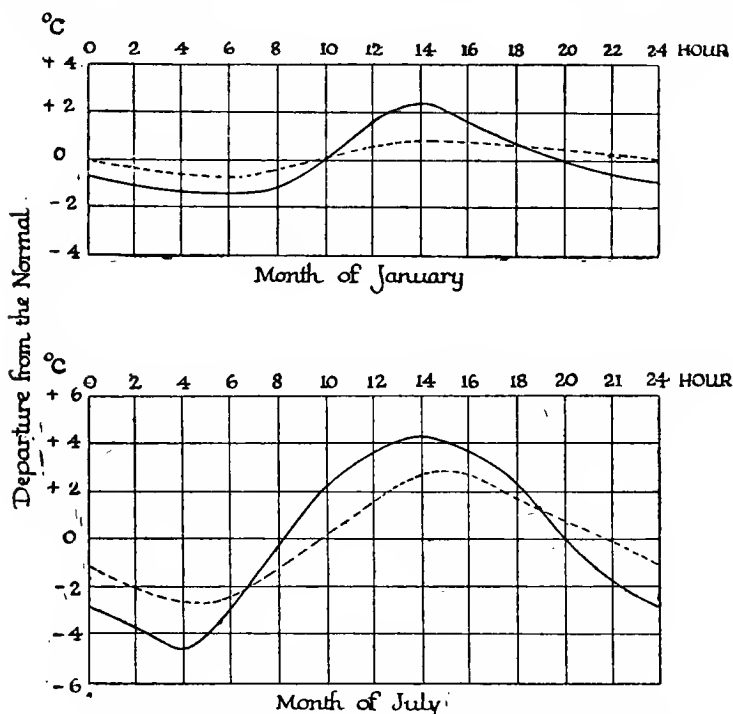

Fig. 21.—Diurnal Variation of Temperature. Effect of altitude (after Angot)

Parc St. Maur ——— Eiffel Tower - - - - -

a considerable effect, however, and it is necessary to go much higher on a mountain than in the free atmosphere to obtain the same results. Further, the station must be well exposed and on as small a mass as possible. If the station is in a valley or on a high plateau the variation increases with height, for as we ascend the air is less dense and there is less water vapour in the atmosphere. Consequently it absorbs less heat in the day-time and also allows radiation from the earth to pass more freely through it at night, thereby producing a much larger diurnal variation.

Annual Variation of Temperature.—To investigate the annual variation of temperature, one could find the average temperature for each day of the year over a sufficiently long period of time, obtaining thereby 365 different values from which a curve could be constructed. Sufficient accuracy can be obtained, however, by taking the average value of the temperature for each month, thereby obtaining 12 different values. Table VII gives the values for

TABLE VII

AVERAGE MONTHLY TEMPERATURE VALUES

	Jan.	Feb.	Mar.	Apr.	May	June	July	Aug.	Sept.	Oct.	Nov.	Dec.
Abn. ...	276·41	76·53	77·27	79·09	81·04	84·50	86·34	86·15	84·33	81·33	78·70	276·69° A.
Kew ...	276·87	77·38	78·63	81·33	84·44	87·92	89·86	89·30	86·75	82·78	79·56	277·36° A.

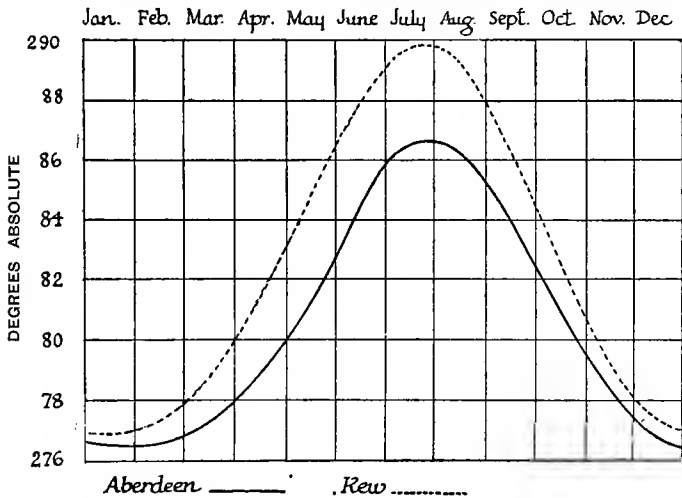

Fig. 22.—Annual Variation of Temperature for the Period 1871-1910

Aberdeen and Kew for the period 1871-1910, and the curves obtained by plotting these values against the time are shown in fig. 22. The minimum falls during the latter half of the month of January and the maximum during the latter half of July. These curves are similar to the curves representing the amount of insolation arriving at the station, but both the maximum and minimum positions fall later in the year than is the case on the insolation curve.

Effect of Latitude on the Annual Temperature Variation.—As the sun crosses the Equator twice every year, therefore two

maxima and two minima are to be expected from observations taken at any point in the tropical zone. This is shown to be so by the observations at Batavia which are represented by curve 1 in fig. 23. The curve is analogous to the curve representing the insolation received in that latitude, only the maxima and minima fall later in the case of the temperature curve. Outside the tropical zone there is only one maximum and one minimum in the

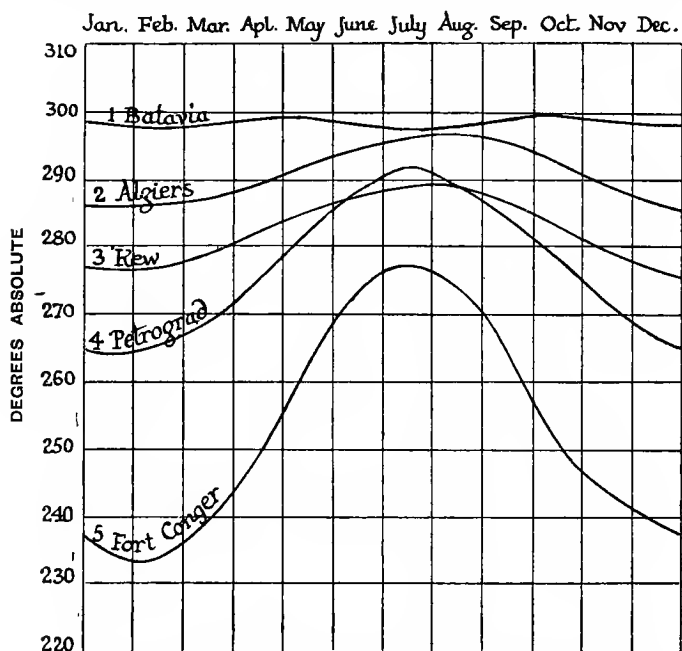

Fig. 23.—Annual Variation of Temperature. Effect of latitude

Batavia, 6° 8' S. Algiers, 36° 47' N. Kew, 51° 28' N. Petrograd, 59° 56' N. Fort Conger, 81° 44' N.

temperature curves, exactly as occurred in the case of the insolation curves. Fig. 23 represents graphically the annual variation for Batavia, Algiers, Kew, Petrograd, and Fort Conger for two years, together with observations made by the *Discovery* for a year near the same place.

The Lag of the Maximum on the Temperature Curve behind the Maximum on the Insolation Curve.—In the case of the diurnal variation, we saw that the temperature continued to increase as long as the amount of radiation received was greater than the amount

radiated out, and that the temperature began to fall when the amount radiated was greater than the amount received. The same thing takes place in the case of the annual variation. While the daily amount of insolation received increases and is greater than the daily amount radiated out, then the effect is cumulative, and the temperature gradually rises. Also, after the maximum daily amount has been received, the amount received is still in excess of the amount radiated out each day, and in consequence the temperature still rises until a point is reached when the amounts received and radiated out are exactly equal. At this point the maximum in the curve is reached, and as this time is now later in the year than the corresponding time on the insolation curve, the maximum and minimum values show a lag on those of the insolation curve.

Two maxima and two minima occur on the insolation curve, and the amplitude is small within the tropics; so also for the temperature curve. Within this region the daily amount of heat received varies little from season to season, but outside the tropical zone the case is different. In the summer-time there is a large area over which the amount of heat received is approximately the same as shown by fig. 9, p. 47, but in the winter-time it is not so. The farther north we go the average amount of heat received in the day becomes ever less and less, with the result that the annual variation in temperature becomes ever larger and larger. This is shown by the curves in fig. 23. Within the Arctic Circle there is a period during which the sun never rises. Consequently the temperature continues to fall during this period of darkness, and continues to do so until after the sun rises again, when the amount radiated will become balanced by the amount received, after which, temperature begins to rise again.

Outside the tropical zone the maximum occurs for all latitudes on the same hemisphere, at approximately the same time, but the minimum varies according to latitude, occurring earlier in low latitudes than in high. In this it resembles exactly the diurnal variation, which at all seasons and latitudes shows the same time for the maximum, but the time of minimum varies according to the latitude and the season.

Causes affecting the Annual Temperature Variation.—If sea and land were equally affected by solar radiation, then the amplitude of the annual variation would increase regularly from the Equator to the poles. But as indicated under the diurnal variation,

water surfaces warm and cool much more slowly than land surfaces, and further, ocean currents tend to equalize the temperature over the surface of the sea in a way which is impossible on land. Also on land, especially over dry, barren areas, the periods of maximum and minimum temperature follow much more closely on the times of maximum and minimum solar radiation than happens over the ocean. From these causes climates have been divided into three main groups, viz. ocean climates, temperate climates, and continental climates.

In ocean climates the annual variation is small, not exceeding 10° A. This type is not altogether confined to ocean surfaces, as in the tropical zone, even in the centre of large continents, the annual variation in temperature is small. The type might, therefore, be more fittingly termed "regular".

The amplitude of the variation in temperate climates is between 10° A. and 20° A., while in continental climates the amplitude exceeds 20° A. In continental areas near the Equator this variation is not found, and the term "extreme" is therefore more suitable for this type.

For stations situated in the equatorial zone and up to lat. 45° the difference between coast stations and inland stations is comparatively small. The mean temperature for coast stations in these latitudes is also lower than that for inland stations. The opposite takes place in higher latitudes, i.e. the mean temperature for a coast station is higher than that for an inland station on the same parallel of latitude higher than 45° , while the amplitude of the annual variation is very much larger inland than on the coast. If we take as examples Funchal and Bagdad, which are nearly on the same latitude, $32\frac{1}{2}^{\circ}$ N., the mean for the first is 291.4° A., and for the latter 296.1° A., while the amplitudes of variation are 7.1° A. and 23.6° A. respectively. For Valencia and Nertchinsk, which are on latitude 52° N. approximately, the values of mean temperature are 283.8° A. and 270.3° A., while the amplitudes of variation are 7.9° A. and 53.9° A. The variation for Nertchinsk is therefore more than double that for Bagdad, while Funchal and Valencia have nearly the same variation.

Other Causes affecting the Annual Temperature Variation.

—These are altitude, high valley positions, plateaux, vegetation, &c., and their effect on the annual variation is similar to their effect on the diurnal variation.

Variation of Temperature with Height above the Ground in the free Atmosphere.—Experiment has shown that the temperature of the air decreases as a rule from the surface upwards. Now it is well known that if a gas is compressed, its temperature is raised, whereas if it be allowed to expand, it becomes cooled. In the next chapter we shall see that pressure decreases with height, and so if a mass of air be raised up from the surface of the earth, the pressure under which it is will gradually diminish, and the air will in consequence expand. By knowing the original temperature and pressure of the gas it is possible to calculate the lowering of the temperature for a given diminution of pressure, provided the expansion takes place adiabatically, i.e. without gain or loss of heat. For dry air this cooling amounts to 1° A. for every 101 m. ascent above the surface. If there is moisture in the air, the law still holds so long as the air is not saturated, only the height increases for the same lowering of temperature according to the amount of water vapour present. As soon as the air becomes saturated, any slight further diminution in pressure causes part of the moisture to be condensed, and this liberates heat, which tends to slow down the rate of cooling. Under atmospheric conditions as generally found, it is calculated that there is a lowering of 1° A. for every 140 m. to 240 m. ascent according to the original conditions. As a mean value 180 m. is generally chosen.

Should the temperature gradient become greater than this, or greater than the gradient for dry air, then when a mass of air rises into the atmosphere, it will continually find itself surrounded by air which is colder than itself, and it will therefore continue to rise farther and farther, or the atmosphere is said to be in a state of unstable equilibrium. If on the contrary the gradient is less than the gradient for moist air, the mass of air will find itself surrounded by air warmer than itself. In such a case the atmosphere is in stable equilibrium. These facts have far-reaching consequences, and it is essential in forecasting that the forecaster have as full information as possible on these points.

Though in general the temperature decreases with height above the surface, up to heights of 8000 ft. or 10,000 ft. (i.e. 2000 m. to 3000 m.) this diminution is by no means regular. Often it is found that there are abrupt increases of temperature in the lower layers called "inversions", information regarding which is also of the utmost importance in forecasting.

From the decrease of temperature with height, one would be apt to think that this decrease would go on regularly until the absolute zero of temperature was reached. So long as manned balloons were used to investigate the upper atmosphere, it was found that this diminution held approximately in the regions investigated. When, however, self-recording instruments were used on *ballons sondes* and heights up to 18 Km. were investigated, the fall of temperature with height was found to disappear, and in some cases to show a reversal in layers above 10 or 11 Km. in temperate regions.

The Stratosphere and the Troposphere.—M. Teisserenc de Bort, in 1899, published the results of his investigations of the free atmosphere, in which he showed that in the layer above 11 Km., a layer which he called the "Isothermal Layer of the Atmosphere", and which has now come to be generally known as the stratosphere, the diminution in temperature ceased with height, and in some cases even a slight increase appeared. Over equatorial regions the layer was found later to exist at heights over 17 Km. Consequently this isothermal layer encircles the whole of the lower layer in which temperature variation with height takes place. At the Equator its lower surface is at 17 Km., and it slopes down to a height of about 8 Km. above the poles. Over the temperate zones the lower surface, as stated above, is at a height of about 11 Km., but this varies slightly from season to season, being higher in summer and lower in winter.

Owing to the difference in height of the undersurface of this layer at the poles and over the Equator, the temperature in the upper air over the Equator falls much lower than it does over the poles.

The atmosphere, therefore, may be divided into three layers: (1) a layer from the ground up to 3 Km. in which the temperature variation with height is irregular; (2) a layer from 3 Km. to 10 or 11 Km. in temperate regions, to greater heights in equatorial regions, and less heights in polar regions, in which there is a regular diminution of temperature with height, approaching closely the adiabatic rate of decrease; and (3) above this the isothermal layer in which decrease of temperature with height ceases. The layers of the atmosphere in which a vertical temperature gradient exists constitute the troposphere. The diminution of temperature with height in this layer ranges from 6° A. to as much as 9° A. per kilometre, which shows that considerable vertical

motion must be taking place. In the stratosphere on the contrary there cannot be vertical motion to the same extent, and the masses of air must glide over one another practically without mixing.

Reduction of Temperature to Sea-level.—In discussing the diurnal and annual variations in temperature, we saw that stations on the same latitude, but at different altitudes gave different values for their mean temperatures. If the values are taken over a sufficiently long period, this diminution with altitude becomes quite regular, and is found to be about 1° A. for every 180 m. (or, 1° F. for 300 ft.). If, then, temperatures are to be compared, it is first necessary to get rid of this effect by adding to each an amount corresponding to the height of the station above some definite level, e.g. the level of the sea. This process is called “reducing the temperature to sea-level”. If a station is 500 m. above sea-level, then in order to compare its temperature values with those of a neighbouring station at sea-level, it is first necessary to add $\frac{500}{180} \times 1 = 2.8^{\circ}$ A. to all values at the former station. A good example is afforded by comparing the reduced and unreduced values for Puy de Dôme and Clermont Ferrand, for which the latitude is the same.

Station.	Altitude.	Latitude.	Unreduced.	Reduced.
Clermont Ferrand	388 m.	$45^{\circ} 46'$	282.3° A.	284.5° A.
Puy de Dôme	1467 m.	$45^{\circ} 47'$	276.3° A.	284.5° A.

The variation of temperature with height varies throughout the year, in summer being about 1° A. for 143 m., and in winter 1° A. for 250 m., giving on an average 1° A. for 180 m.

Construction of Isothermal Charts.—At many stations all over the globe observations of temperature have been made for many years, and the mean values of temperature for these places have been determined. If these values be plotted on a chart of the world, it is possible to draw lines through the points showing equal values. These lines are called Isothermal Lines, or Isotherms, and are such that the values on one side of them are all higher, and on the other side all lower, than the values on the line itself. The lines so obtained, however, would afford little information if the values were not first all reduced to some common level, e.g. sea-

level. If this reduction is not made the lines tend to follow the contours of the land, thereby exhibiting great irregularities. But on reduction to sea-level they show a definite distribution of temperature over the globe. In general terms, the maximum value is found near the Equator, a minimum round each pole, and a decrease from Equator to pole. Alexander von Humboldt was the first to draw these charts, the first chart being drawn on the mean values for the year. Later summer and winter charts were added. The first monthly charts were drawn by Dove. Owing to the lack of observations over large areas, especially in the Southern Hemisphere, the isothermal lines cannot claim to represent the values accurately over these regions, and require to be altered as additional information is received.

Causes of Irregularities in the Isothermal Lines.—If the surface of the globe were uniform, so that the behaviour towards solar radiation was everywhere the same, then the isothermal lines would be circles parallel to the thermal Equator. The first glance at Chart I, which represents the isotherms for the year, shows that this is not the case. The causes for this variation have been discussed in considering the diurnal and annual temperature variations. The effect of land and sea is evident, for in the Northern Hemisphere, where the land area predominates, the lines are much more irregular than they are in the Southern Hemisphere, where the ocean area predominates. In the northern Atlantic the effect of ocean currents is well marked, for on the eastern side the isotherms bend towards the north through the effect of the Gulf Stream, whereas, on the western side, the cold Labrador current flowing southwards along the American coast causes the lines to bend southwards. The difference in the behaviour of the isotherms over Brazil and the Sahara shows the effect of vegetation.

The Thermal Equator.—If the highest temperature on each meridian be taken and these points be connected, then there is obtained a line encircling the globe. This line is called the Thermal Equator. It is not an isothermal line, as the temperature along it is not constant. An examination of Chart I shows that the thermal Equator lies to the north of the geographical Equator. On the Atlantic and Pacific it approaches the geographical Equator, but over land areas it bends considerably to the north, reaching lat. 20° N. in Mexico and India and even a little farther in Africa. As it passes over these land areas, it passes

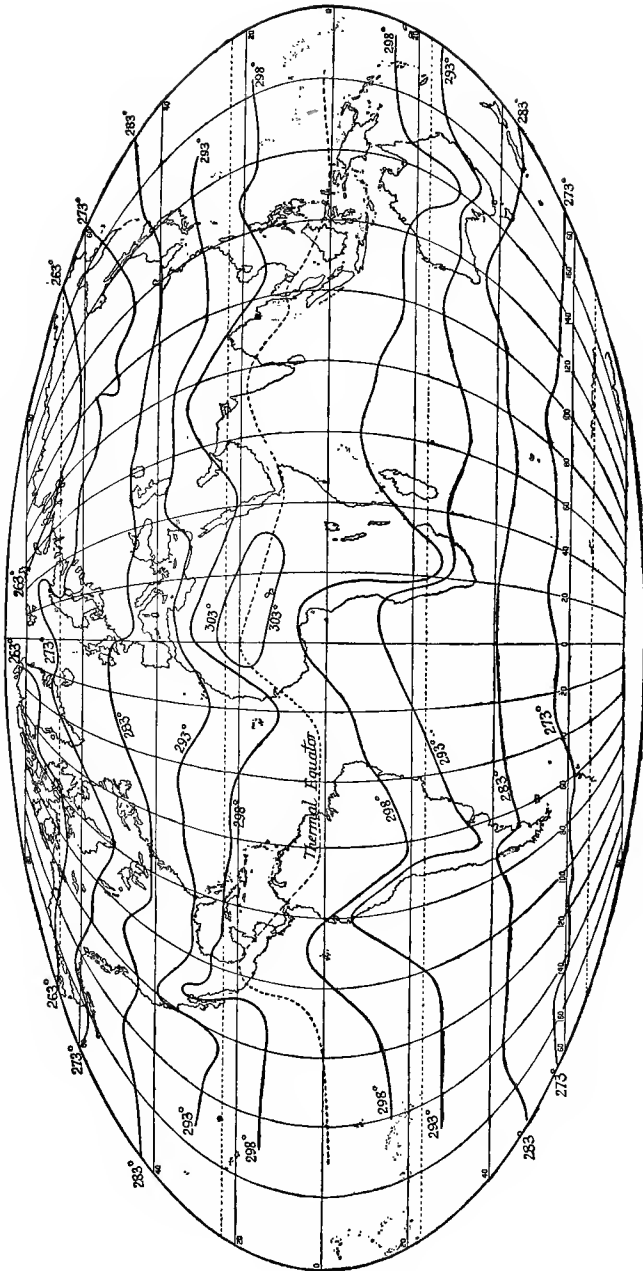

Chart I.—Annual Isotherms in Degrees Absolute (after Angot)

through maximum temperature values, for in the equatorial zone, the isotherms of maximum value do not pass right round the earth, but form closed curves over the land areas, the absolute maximum falling within the Sahara.

The reason for the thermal Equator lying to the north of the geographical Equator is to be found in the difference in the proportion of land to sea in the two hemispheres. The mean temperatures of the land from the Equator to lat. 45° is greater than that of the sea, and consequently within these limits the hemisphere which has the larger amount of land will possess the higher annual mean temperature, and so the thermal Equator falls within the Northern Hemisphere. On the other hand, for latitudes higher than 45° , the mean temperature in the Northern Hemisphere should be less than the mean temperature for the same latitude in the Southern Hemisphere. Reference to the chart will show that that is so.

Isotherms for January and July.—The isotherms for these two months are shown in Charts II and III. The chart of annual isotherms affords no idea of the variation of temperature at any particular spot, but this variation can easily be traced by using monthly charts. We shall consider briefly those for January and July as being typical of summer and winter.

On the Southern Hemisphere in January, i.e. in summer, the isotherms run nearly parallel to the Equator, except over the three continents of South America, South Africa, and Australia. There is in each of these three continents an area enclosed by an isotherm of 303° A., and all other isotherms bend southwards when passing over the land areas. In July, i.e. in winter, the isotherms run nearly parallel to the circles of latitude except on approaching the western coasts of South America and South Africa, where, on account of the cold currents flowing northwards from the Southern Ocean, they incline northwards.

On the Northern Hemisphere in both months the isotherms are much more irregular than in the southern. In January the greatest irregularity can be seen by following the 273° A. isotherm. South of this isotherm the lines run a little more regularly than it itself does, but to the north they are even more irregular. Round the pole the curves are very irregular, and the 238° A. isotherm which encircles the pole approaches it much closer on the Atlantic side than on the Pacific side. This is perhaps due to a larger land area on the Pacific

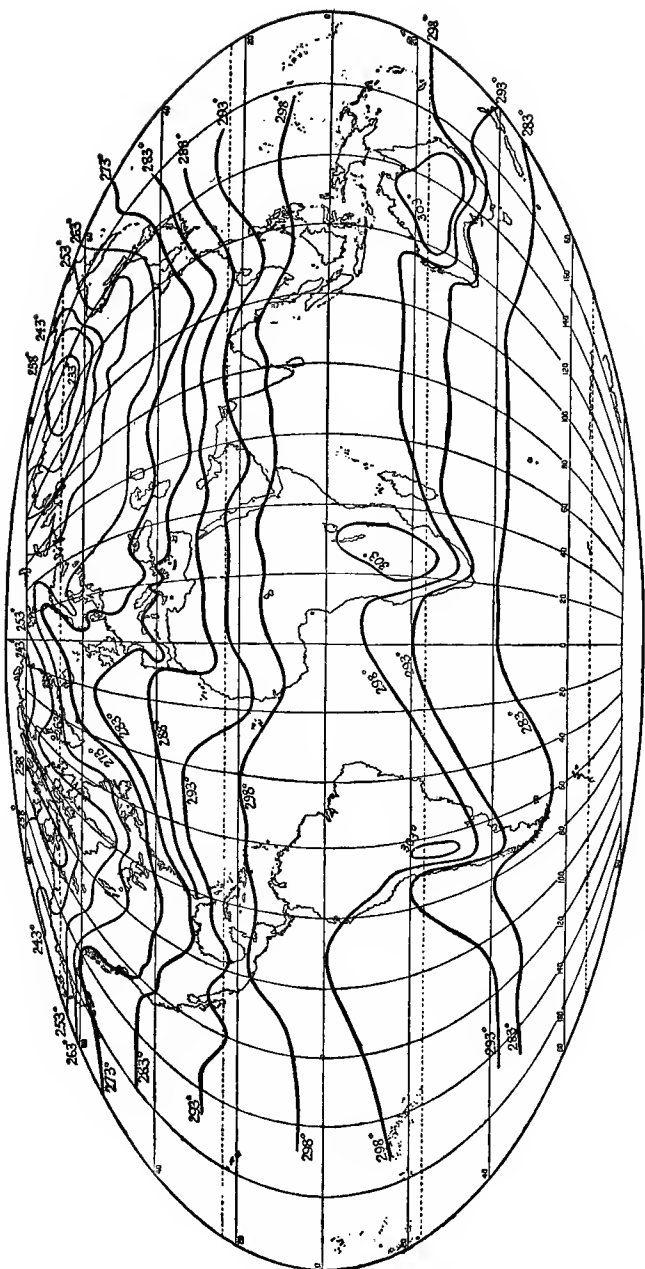

Chart II.—Isothermal Lines for January in Degrees Absolute (after Angot)

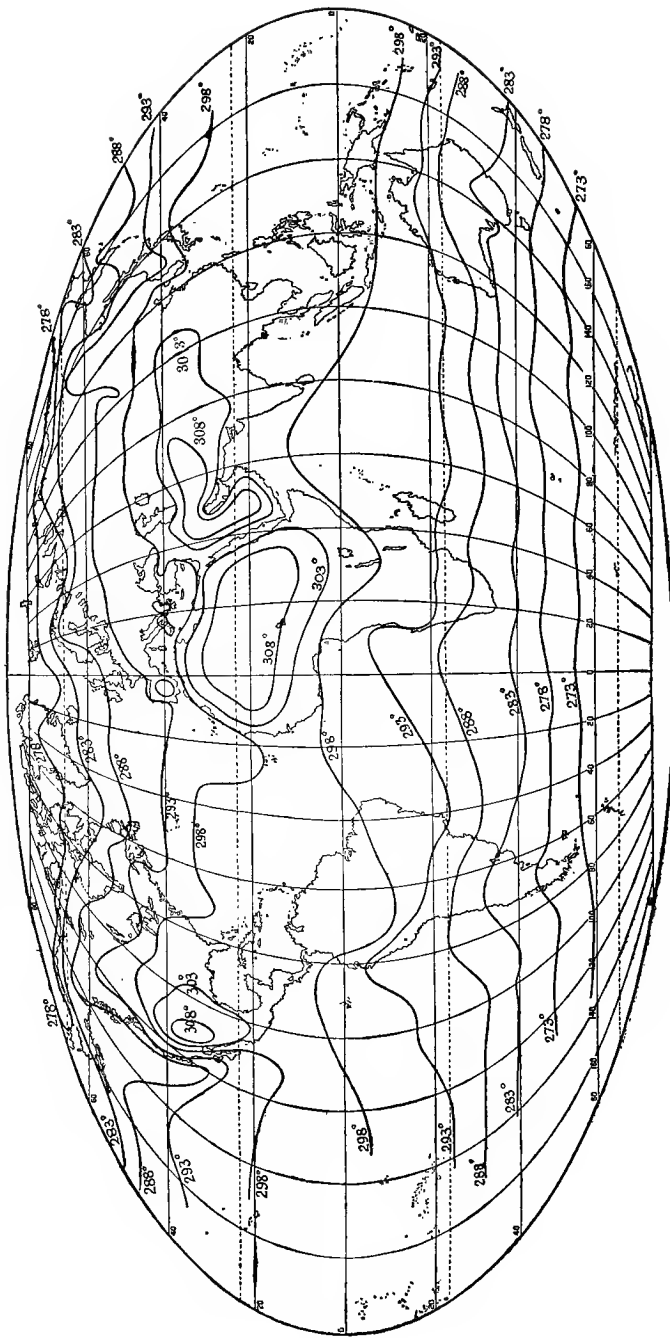

Chart III.—Isothermal Lines for July in Degrees Absolute (after Angot)

side than on the Atlantic side. The region of lowest recorded temperatures is in Northern Siberia, where the mean temperature falls to 233° A., and where at Verkhoyansk in lat. $67\frac{1}{2}^{\circ}$ N. the mean for the month is 221.8° A. This is the lowest mean temperature for a month so far recorded anywhere on the globe. The situation of the place is very favourable for this to happen, for in it are combined practically all the necessary conditions for lowering the temperature. In July the greatest irregularities occur between the

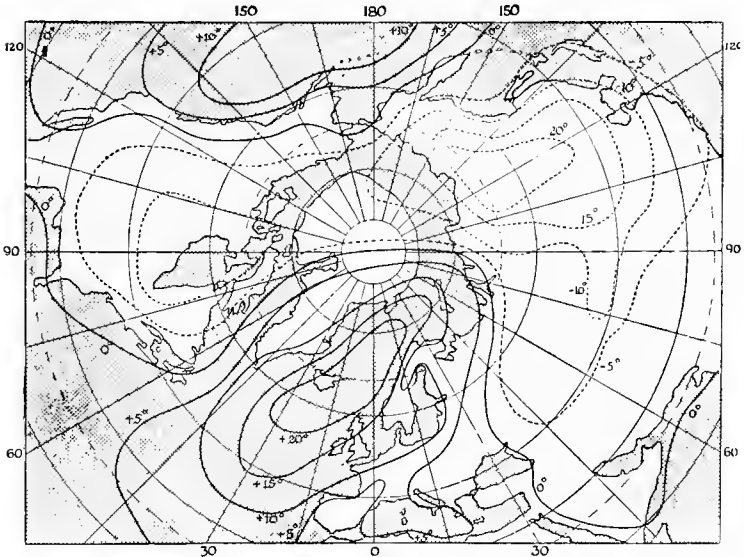

Fig. 24.—Isanomalies of Temperature for January in Degrees Absolute (after Angot)

Equator and lat. 45° . Three maxima occur, one over north-west Mexico and the south-western States, the second over the Sahara and the Soudan, and the third over Arabia and part of Central Asia. For these three areas the mean value is above 308° A. in every case, while the absolute maximum is found over the Sahara.

The Motion of the Thermal Equator.—From the monthly charts one can see that the thermal Equator follows the motion of the sun to a certain extent. But by reason of the large mass of land in the Northern Hemisphere, the motion towards the north in July is more pronounced than that towards the south in January.

Construction of Isanomalous Curves.—From isothermal charts the mean temperature for every parallel of latitude for any

definite period can be found. If then the mean values for the period in question, corrected to sea-level, be taken for stations lying on a particular parallel of latitude, and these values be subtracted from the mean for the parallel in question, then a series of numbers are found called "temperature anomalies". Curves drawn through places where these values are equal are called Isanomalous Curves. Over the northern Atlantic in January there is a positive anomaly exceeding 20° A., i.e. this region is

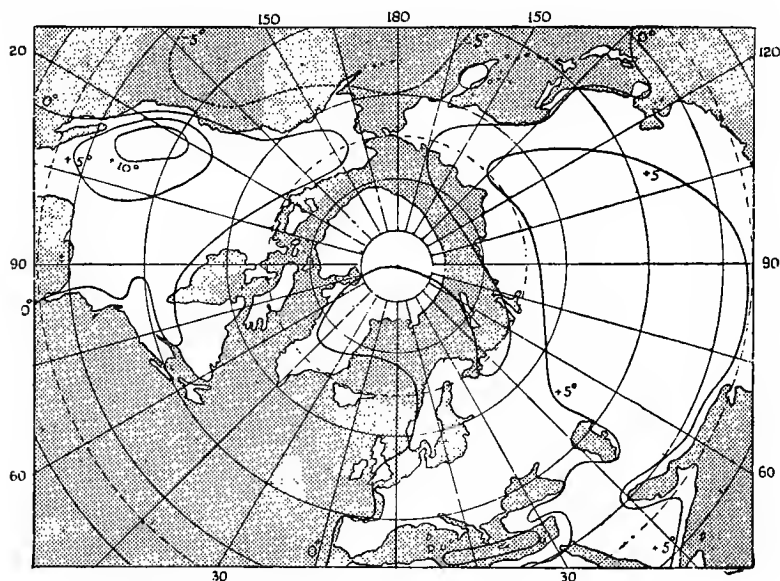

Fig. 25. —Isanomalies of Temperature for July in Degrees Absolute (after Angot)

20° A. warmer than the mean of that latitude, while over northern Siberia there is a negative anomaly of 20° A. In July the positions are inverted, the negative anomalies are over the ocean and the positive over the land, but the values are much smaller, a positive anomaly of 5° A. over Central Asia and America and a negative one of 5° A. over the Pacific, showing that the distribution of temperature in summer over the Northern Hemisphere is much more regular than in the winter-time. Figs. 24 and 25 represent the isanomalous curves for January and July.

Extremes of Temperature.—The lowest temperature ever observed on the surface of the earth was at Verkhoyansk, in Siberia, on 15th January, 1885, when the value reached was -68° C. on

an alcohol thermometer. The value on a hydrogen gas thermometer would therefore probably have been below 205° A. The highest temperature ever reached was 326° A. at Ouargla, in Algeria, on 17th July, 1879. Over northern Siberia the temperature has been known to fall in November to the neighbourhood of 223° A., and continue at this level until about the middle of March. On the other hand in the summer-time a mean maximum of 304.5° A. has been reached. Yet so dry, calm, and clear is the air in winter over that region that the inhabitants appear to be able to bear these extremes comparatively easily. The range over North America is smaller than that over Siberia, though extremes of 220° A. and 321° A. have been reached. Such extreme values do not occur in the British Isles by reason of the comparative proximity of all parts to the sea.

B. LAND AND WATER TEMPERATURES

Temperature of the Ground.—The crust of the earth is a very bad conductor of heat, so that when the solar radiation falls on it a very thin layer is warmed up to a considerable degree every day. At night under favourable conditions radiation from the surface is considerable, and temperature falls. Thus, if a thermometer is placed just under the surface, it may register a temperature from 10° A. to 15° A. higher than the temperature of the air a few feet above the ground. In the hot deserts of Australia and the Sahara it sometimes shows 20° A. or 30° A. above the air temperature. On the other hand the temperature may fall 15° A. below that of the air, especially if the ground is covered with snow. There is in this way a considerable daily oscillation of temperature just at the surface of the earth, and the problem of the propagation of this oscillation into the crust of the earth can be easily solved theoretically, on the assumption that the earth's crust is homogeneous and that the oscillations are small harmonic oscillations. •

From this assumption three laws of propagation can be deduced, and these laws are found to be in agreement with observation.

(a) The amplitude of the oscillation decreases in geometrical progression as the depth increases in arithmetical progression.

(b) The lag of the time of maximum and minimum is proportional to the depth.

(c) For oscillations of which the periods are different, the am-

plitudes are reduced in the same proportion at depths which are in the ratio of the square roots of the periods of the oscillations. Also the same retardation of maximum or minimum value occurs at these depths after the same fraction of the complete period of oscillation.

Diurnal Oscillation.—Suppose that the amplitude of the oscillation on the surface is 16° A., and at a depth of 6 in. it is only 8° A. Then at a depth of 5 ft. it is only $\frac{1}{4}^{\circ}$ A., i.e. at that depth

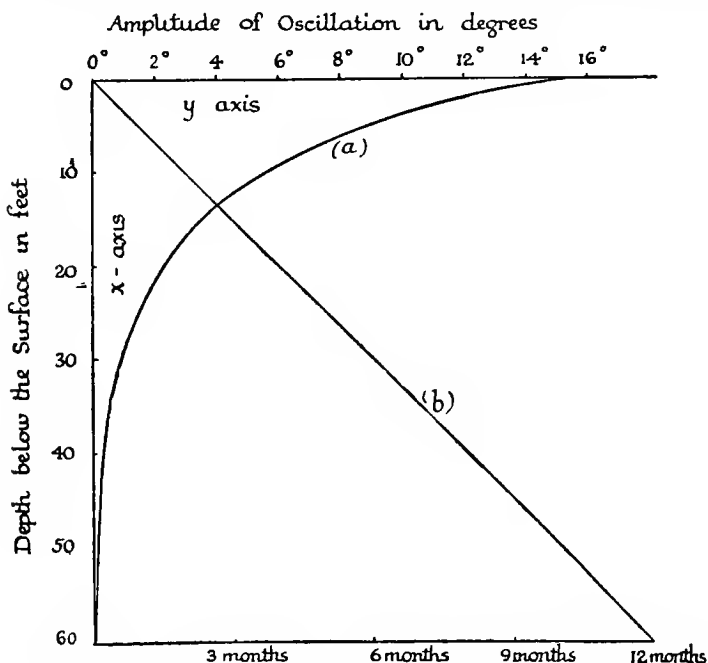

Fig. 26.—a, Curve showing Amplitude of Temperature Oscillations at different depths.
b, Line showing Lag of Maximum Temperature with depth.

the diurnal oscillation becomes inappreciable. At the depth where the amplitude is reduced by $\frac{1}{2}$, the period of maximum value lags $\frac{1}{4}$ of the period of oscillation behind the time of maximum at the surface. At a depth of $2\frac{1}{2}$ ft., therefore, the time of maximum lags by $\frac{24 \times 5}{9} = \frac{40}{3} = 13\frac{1}{3}$ hr., or at $2\frac{1}{2}$ ft. below the surface the time of lag would be 12 hr., and at $4\frac{1}{2}$ ft., 24 hours.

Annual Oscillation.—On the same hypothesis the amplitude of the annual oscillation will be reduced by $\frac{1}{2}$ at a depth of $\frac{1}{2}\sqrt{365\frac{1}{4}}$ = $\frac{1}{2} \times 19.1 = 9.6$ ft. approximately, and so on, while the lag at

this depth will be $\frac{365\frac{1}{4}}{9} = 40.6$ days. A lag of 6 months will therefore take place at a depth of $19.1 \times \frac{9}{4} = \frac{171.9}{4} = 43$ ft. approximately. Observation, however, shows that in temperate climates a lag of 6 months takes place at a depth of from 25 ft. to 30 ft., and therefore the original depth chosen, viz. 6 in., was too large, 4 in. being nearer the true value. At 60 ft. below the surface the lag in the annual oscillation is a whole year, and at this depth the amplitude of the annual oscillation has fallen to zero. The range at different depths, and the lag of maximum temperature with depth, are shown in fig. 26. If we choose the point on the surface as the origin, and the x -axis represents the depth, while the y -axis represents the amplitude of the oscillation in the one case and the time of lag of maximum temperature in the other, we obtain as equation for the curve $y = Aa^{-x}$, and for the straight line $y = mx$, where A and m are constants. The amplitude of the annual oscillation at the surface is for the particular case of fig. 26, 16° A. The longer the period of oscillation the farther the oscillation penetrates into the earth, the distances being in the ratio of the square roots of the periods.

Effect of Snow.—If the ground be covered with a layer of snow, which is a bad heat conductor, the heating due to the solar radiation penetrates only to a very short distance. Similarly cooling at night to any great depth is prevented. This explains why frost penetrates a much less distance into the ground when snow is lying. Any other bad conducting substance will produce the same effect.

The Invariable Layer.—At a certain distance below the surface, approximately $3\frac{1}{2}$ ft. in temperate regions, the diurnal oscillation disappears. At 19.1 times that distance the annual oscillation disappears. At this depth there is found a layer in which the temperature is the same all the year round, and this layer is known as the Invariable Layer. Slight secular changes take place in the layer, but they seldom amount to more than one- or two-tenths of a degree. The depth of the layer varies from latitude to latitude, and is dependent also to a certain extent on the nature of the soil. In tropical regions it is found at depths generally less than 20 ft., and in South America some places near the Equator show it at a depth of about 3 ft. The mean value of the depth in temperate

countries is about 60 ft., while in the polar zones it is found at a still greater depth. Beneath the invariable layer temperature rises again, the rate of increase being about 1° A. for every 100 ft., though this value also varies, places which are quite close to one another often showing a marked difference even when the nature of the strata passed through is apparently the same.

Temperature of the Sea.—When solar radiation falls on the surface of the sea about 40 per cent of it is reflected off again. Also the specific heat of water is high compared with that of soil, and consequently both the diurnal and annual amplitudes of the temperature oscillations are much smaller over the sea than over the land, while the periods of maximum and minimum values are greatly retarded. The diurnal variation even in the tropics amounts only to about 1° A., while the maximum occurs about 16 h. The annual variation differs widely with latitude, and is affected largely by ocean currents and by proximity to land. In inland seas this variation is much greater as a rule than over the open ocean. At the poles the temperature on the surface is 271° A., and at the Equator nearly 300° A., the mean maximum value of 300° A. being found about lat. 5° N. There is little annual change at either of these places. The biggest annual variation takes place in mean latitudes, the variation at New York, for example, being about 22° A., which is perhaps the largest variation on the Atlantic.

Causes of Surface Temperature Variations.—The variations on the surface of the ocean are largely due to ocean currents. These currents are for the most part superficial, though in places they have a depth of 3000 ft. There are several causes producing them, but the prime cause is the circulation of the atmosphere. They follow in general the direction of the air currents. Let us consider briefly the circulation in the north Atlantic. About lat. 15° N. a current flows from the west coast of Africa westwards, and the major portion of it, passing north-westwards, enters the Gulf of Mexico, and thence flows out between Florida and the Bahamas by the Florida canal, where it reaches a velocity of 4 or 5 miles an hour owing to the narrowness of the exit. It continues north-eastwards, and is joined north-east of the Antilles by a portion of the original westerly current which did not enter the gulf. In mid-Atlantic, about lat. 40° N., this combined current divides into two, the southern branch turning southwards along the

coast of Africa to feed the westerly equatorial current, and the northern branch flowing northwards to the western shores of the British Isles and Norway on the one side and Iceland on the other. From there it flows out into the Arctic Ocean to feed the cold currents coming down the eastern coasts of America. This Arctic current, known as the Labrador current, reduces the sea temperature considerably on the American coasts, with the result that the Gulf of St. Lawrence is ice-bound for a considerable portion of the year, while the temperature at New York is only 279° A., though on the Atlantic in the same latitude in the Gulf Stream it reaches 291° A. The north-west coasts of Europe are therefore greatly benefited by this current, but as only a small portion reaches the coasts of France and the Peninsula the effect on these south-western coasts is much less marked. The portion of the current reaching the south-west has been moving from westwards for some time, whereas the portion arriving on the north-west has been moving from the south-west, and further is much greater in volume. When one considers the difference in latitude, therefore, the advantage to these northern countries is much greater than to the southern.

A large area where the surface of the ocean is nearly stationary, and known as the Sargasso Sea, is surrounded by the western equatorial current and the southern portion of the Gulf Stream as it moves north-east, east, and then south.

A circuit similar to that on the north Atlantic is found over the northern Pacific, while in the southern portions of these two oceans exist other two circuits. The direction of motion in these two is in the opposite sense from the two on the Northern Hemisphere, in this following the direction of motion of the atmosphere.

The complete circuit is made in about three years by the currents on the north Atlantic, the velocity with which the current issues at Florida becoming considerably reduced as the current spreads out across the Atlantic. The average velocity of the currents in this and all other oceans, and hence the mass of water transported by them, depends chiefly on the strength of the winds producing them. There are some minor causes, such as the difference in salinity, but the principal cause is found in the winds, and therefore in the distribution of pressure over the surface of the globe. But the distribution of pressure is due to the differences in temperature over different regions, and so we are brought back to

the differences in temperature as being the prime factor in the development of ocean currents.

Temperature at the Bottom of the Sea.—At the bottom of the ocean there is only very slight motion, and the difference in temperature between the Equator and the poles is but small, amounting to 4° A. only, the value at the poles being 271° A., and at the Equator 275° A. Fresh water is densest at 277° A., but as sea water contains considerable quantities of various salts in solution, the principal being sodium chloride, the density depends on the quantity of salt in solution. The maximum density is found about 3° or 4° A. below the freezing-point of fresh water, and the temperature at the bottom of the Arctic Ocean, viz. 271° , is approaching this value. The temperature of sea water therefore decreases from the surface downwards to the bottom, and the cold water from the poles being heavier than the warm water over the Equator, sinks down to the bottom, so that even at the Equator the temperature at the bottom of the sea is very low, falling to 275° A., as stated above. In exceptionally deep parts it has been found to be in the neighbourhood of 273° A. Now, whereas the temperature of the soil rises below a shallow layer amounting only to 60 ft. even in temperate climates, the temperature of the sea decreases all the way to the bottom. The temperature, therefore, at the bottom of a large inland sea connected by a strait with the open ocean will depend to a large extent on the temperature of the water in the ocean at a depth equal to that of the passage connecting the two. If, however, the temperature of the air over the inland sea in winter is less than this temperature, the temperature at the bottom of this sea will be that of the air in winter. Hence, for a sea which is entirely closed in, the temperature at the bottom becomes that of the air over the sea in winter.

In the first case, if the temperature of the air in winter is greater than the temperature of the sea at the bottom of the strait, then all the water from that level to the bottom will have the same temperature. The Mediterranean affords a good example of this, as at the Straits of Gibraltar the depth is only about 1200 ft., and in the Mediterranean, from this depth right down to 10,000 ft., the temperature is constant, being 285.8° A., which is the temperature in the Atlantic off the Straits at a depth of 1200 ft. Consequently, the difference in animal life in the Atlantic and in the Mediterranean at the depth of 10 000 ft. is easily explained.

Temperature of Springs.—Below the invariable layer the temperature of the earth increases with depth. Therefore, if water rise to the surface from depths below this layer it will issue with approximately the temperature of the layer from which it came, and thus there is found an explanation for the temperature of hot springs. But if, on the contrary, the water be due to the melting of snow on the mountain-sides filtering a short distance into the earth and then rising to the surface lower down the mountain-side, the temperature of the spring water will be below the air temperature. Similarly, if the spring is fed by rain, the temperature will be below that of the air, the temperature in each case depending partially on the temperature of the water at the point where it began to filter into the earth, and partially on that of the layers through which it passed before reaching the surface again.

Temperature of Lakes.—In the summer-time in deep lakes the temperature decreases gradually from the surface to the bottom, provided that the temperature nowhere falls below 277° A. At this temperature water is densest, and its density decreases at temperatures both above and below this value. The water, therefore, arranges itself in layers of decreasing density from the bottom upwards. In winter the water on the surface falls in temperature, and, as it becomes colder than the underlying layers, sinks to the bottom until a layer at 277° A. is formed there. The cooling will continue until the whole lake is at this temperature. If the temperature of the water near the surface falls below this it becomes lighter again, so that the distribution now is a layer of water at the bottom with a temperature of 277° A. and above it, layers of gradually decreasing temperature and density until the surface is reached. If the surface fall below 273° A., part of the water freezes, and, as ice has a less specific gravity than water, this frozen layer rests on the top. With the coming of spring the top layer warms up first, and the warming continues until the whole lake is at 277° A. again, after which the temperature gradually increases from the bottom upwards.

Temperature of Rivers.—If the river be deep and slow the behaviour in general is very much like that of a lake. If shallow, owing to the continual mixing taking place its temperature is practically the same throughout. On the whole the mean temperature of rivers is about 2° A. higher than that of the surrounding air. This is accounted for by the water being transparent to the

short waves of solar radiation, but not to the long waves of terrestrial radiation, and, consequently, heat tends to accumulate. Sometimes rivers are fed by water rising from a depth below the "invariable layer", and their temperatures are in consequence higher all the year round than they otherwise would be. The temperatures of lakes are affected in the same way but to a less extent.

CHAPTER V

Pressure and the General Circulation of the Atmosphere

A.—PRESSURE, OR ELASTIC FORCE OF AIR: ITS OBSERVATION AND DISTRIBUTION

Definition of Pressure.—In Chapter II, we saw that a quantity of air admitted to any space filled all parts of the space and exerted a pressure on all sides of the containing vessel equally. Also according to Boyle's Law this pressure is inversely proportional to the volume of the gas, provided the absolute temperature remains the same. Air, therefore, like any other gas, possesses a certain elastic force. But air has also weight and, therefore, for equilibrium, the elastic force which the air possesses at the surface balances the weight of the column of air stretching from the surface to the limits of the atmosphere. The term atmospheric pressure is used in consequence to denote either the elastic force or the weight which it supports.

Pressure Continually Varying.—As one ascends in the atmosphere the length of the air column above diminishes, and, therefore, the weight to be supported diminishes, or the pressure decreases from the surface upwards. Were there no differences of temperature, then the mass of air surrounding the globe would be arranged in layers, and pressure would everywhere be equal for the same height above sea-level. But owing to temperature differences the air is constantly in motion, and pressure is different at different points on the earth's surface, and is also continually changing at any one point.

The Barometer.—The human body is a rough indicator where temperature changes are concerned, but there is perhaps no other meteorological element to the *small* changes of which the human body is apparently so insensible as it is to those of pressure, though

if the changes be large, the effects are quite marked. To indicate the small changes of pressure, therefore, which take place at the earth's surface, an instrument is required, and this instrument has been called the barometer.

There are two kinds of barometer employed, one with a fluid and one without. Mercury is the fluid generally employed, and for this reason this type of barometer is called the mercurial barometer. Sometimes water is used as the fluid, and one or two barometers

have been built using glycerine. The objection to water or glycerine as fluid is the enormous size of the instrument, which must have a length of over 35 ft., and, consequently, becomes very difficult to transport. The other type of barometer employed is the aneroid barometer, i.e. a barometer without fluid.

The Mercurial Barometer.—This barometer in its simplest form consists of a long glass tube about 36 in. long, closed at one end, filled with mercury, and then inverted over a basin of mercury. Such was the type of barometer

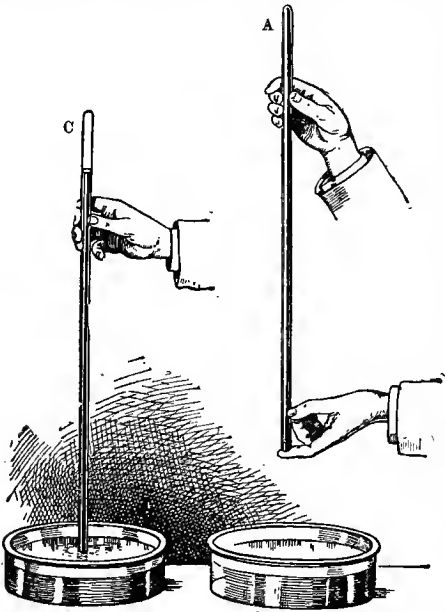

B Fig. 27.—The Simple Barometer

invented by Torricelli in 1643, as indicated in Chapter I, page 3. Torricelli maintained that it was the pressure exerted by the atmosphere which supported the column of mercury, and this was definitely proved by Pascal when, in 1648, he showed that a diminution in the length of the column took place on ascending the Puy de Dôme, the length at the top of the mountain being about 3 in. less than at the bottom. In fig. 27 A represents the glass tube filled with mercury after inversion. If the finger be kept over the open end, the tube can be placed over the basin B, which also contains mercury. When the open end is below the surface of the liquid in this basin, the finger is removed, and it is

found that the mercury in A falls to the level C. The difference in the levels between the surfaces at B and at C gives a measure of the atmospheric pressure. For within a heavy liquid at rest, pressures on the same horizontal plane are equal, and so the pressure on the surface of the liquid in the vessel must be equal to the pressure at the bottom of the column. On the surface there is the pressure due to the atmosphere, and at a point within the column there is only the weight of the mercury above the point, as the top part of the tube is an absolute vacuum, and as there is equilibrium these two must balance. The vacuum at the top of the column is known as the Torricellian vacuum.

The Standard Barometer.—The changes in the length of the mercury column of the barometer show the changes in the atmospheric pressure, but in the simple barometer described above, it is impossible to determine these changes with great accuracy. Consequently two types of mercurial barometer have been devised, and are in use at the present day for measuring the atmospheric pressure accurately. These are (1) the Fortin Barometer, and (2) the Kew Pattern Station Barometer or the Kew Pattern Marine Barometer. Both of these types consist essentially of a glass tube about 3 ft. long dipping into a vessel containing mercury, called the cistern. The glass tube is enclosed in a cylinder of brass in order to protect it, and also to afford a means of suspending it. Near the top this brass case is cut away on two sides to enable the top of the mercury column to be read.

The Fortin Barometer.—In the Fortin Barometer the glass tube is of the same bore throughout, except for a small constriction at the point where it enters the cistern, whereby a support is provided. The top of the brass

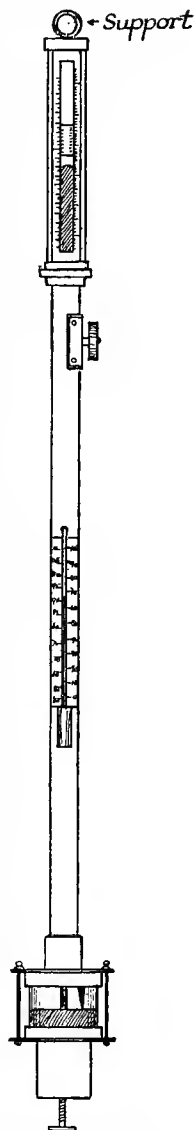

Fig. 23.—The Fortin Barometer

scale is divided into inches and twentieths on the one side and

millibars on the other, and by means of a vernier a reading can be found to a tenth of a scale division. A thermometer is fixed on the stem with its bulb in contact with the tube, in order that the temperature of the mercury may be known when the barometer is read. The divisions on the scale are exactly equal, and so to maintain the surface of the mercury in the cistern always at the same level, as it would otherwise alter with the rise and fall of the mercury in the tube, the bottom of the cistern is made adjustable by means of a screw. The barometer when mounted is hung from the top, but it is not free to swing, as it is kept in position by a ring with three adjustable screws placed round the cistern. Fig. 28 represents the Fortin barometer.

The Kew Pattern Barometer.—In the Kew Pattern Station Barometer, fig. 29, which is the type now generally used at observation stations in the British Isles, there is no adjusting screw at the bottom of the cistern, so that to allow for the rise and fall of the mercury in the cistern, the divisions on the scale are not all equal. Above the reading corresponding to 1000 mb., when the instrument is at its fiducial temperature, the divisions on the scale are less than the true length, and below this point they are greater. No adjustment of the mercury column is required before reading, as happens in the case of the Fortin Barometer.

This type of barometer is supported on gimbals fixed well above the centre of gravity so that it may always hang vertically. In some of the station barometers the tube is considerably constricted for a large part of its length, and all marine barometers have this constriction. This is to prevent "pumping", which would otherwise occur on board ship whenever the boat began to rock.

Reading the Barometer.—In order to read a barometer of the Fortin type, it is first of all necessary to adjust the level of the

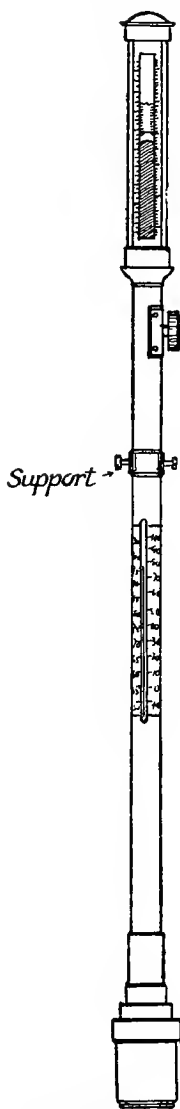

Fig. 29.—The Kew Pattern Barometer

mercury in the cistern by bringing it to the zero position, as indicated by the tip of an ivory peg which is fixed to the top of the cistern and points down towards the mercury. The vernier is then adjusted so as to be tangential to the top of the column, care being taken to avoid any error due to parallax, and the value read on the scale. This value has to be corrected in the following ways:

(1) **CAPILLARITY AND INDEX CORRECTION.**—As mercury does not “wet” glass, the top of the column is lowered slightly through the force of capillarity. This error is determined by comparison with a known standard barometer, and as the error remains constant its value is supplied by the maker.

(2) **CORRECTION FOR TEMPERATURE.**—The temperatures outside and inside a room often differ by several degrees, but not so with pressure. Consequently both the mercury column and the brass scale will each have expanded. The temperature at which the columns give the correct value is supplied, and for temperatures differing from this value corrections must be applied. If the pressure be measured in absolute units or millibars, then there is only one temperature corresponding to each latitude, which will be such that the readings indicated by the barometer are the correct values. This temperature is called the fiducial temperature. If the pressure be measured in inches, the mercury column is correct at 273° A. or 32° F., and corrections have to be made for all values differing from that value, while the brass scale is assumed to be correct at 62° F.

(3) **CORRECTION TO SEA-LEVEL.**—Pressure decreases with altitude, and therefore pressure observations made at different altitudes must all be reduced to a common level before they can be compared. For this purpose the level generally adopted is the level of the sea, and to all readings there must be added a correction which is equivalent to the weight of a column of air, whose height is the height of the station above sea-level. The temperature of the column should be the mean of the temperature of the station and that at sea-level, but as only the temperature of the station is known, an approximate value for the temperature is got by reducing it to a level midway between the station level and sea-level.

(4) **CORRECTION FOR LATITUDE.**—Gravity varies from one latitude to another, being greatest at the poles and least at the Equator,

The value at lat. 45° is therefore regarded as standard. Tables for the calculation of corrections 2, 3, and 4, are to be found in the *Observer's Handbook of the Meteorological Office, London*.

The Aneroid Barometer.—This instrument consists essentially of a vacuum box made of German silver with corrugated top and bottom. It was invented by Vidi in 1848, and a common type is about $1\frac{1}{2}$ in. in diameter, and $\frac{1}{4}$ in. thick. It is exhausted, sealed, and kept from collapsing by means of a spring which extends over the box. When pressure increases, the sides are pressed together against the action of the spring. When pressure decreases, the elasticity of the spring causes the box to expand again. These motions are magnified by means of a system of levers, and are communicated to a pointer which indicates the values on a dial graduated in inches or other units to correspond to the readings of a mercury barometer. There are no capillarity or gravity corrections, but the barometer is slightly affected by temperature, and to allow for this a small quantity of air is often left inside. The instrument is then called a "Compensated Aneroid". Compared with the mercurial barometer it is an inaccurate instrument, but if it be adjusted regularly by comparison with a mercurial barometer and be not roughly handled, its readings are generally correct to within $\frac{1}{10}$ in. Its great advantage is its portability.

Barographs.—For many purposes it is essential to have a continuous record of barometric pressure, and this can be obtained by means of a barograph. The barograph in use in British meteorological stations consists of eight boxes similar to those used in an aneroid barometer, and placed one above the other. This renders the instrument more sensitive, and tends to eliminate any irregularity in any particular box. Fig. 30 (see Plate I) represents the type used. The motion of the boxes is communicated by means of a system of levers to an arm which carries a pen containing non-freezing glycerine ink. A record of the pressure is then obtained on a chart placed on a revolving drum, the system being the same as for the thermograph.

Photographic Barograph.—In observatories, in order that a more accurate continuous record of pressure be obtained than is possible by means of an aneroid barograph, a photographic barograph is employed. The barometer in this case is a mercurial barometer. A beam of parallel light falls on the top of this barometer, and is then focused on a strip of sensitive paper wound on a

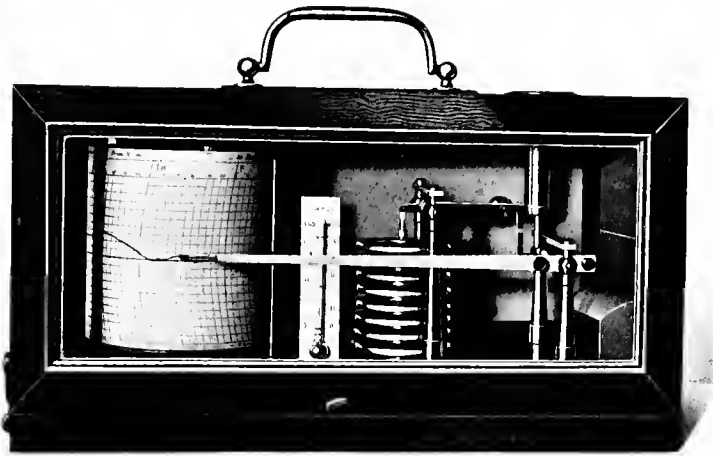

Fig. 30.—Barograph, M.O. pattern

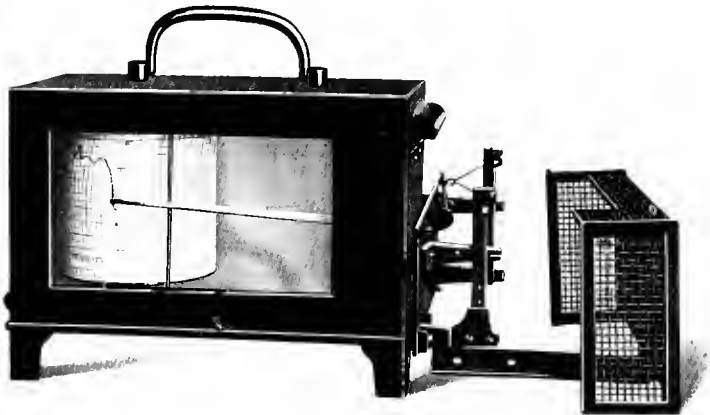

Fig. 53.—Hair Hygrometer, M.O. pattern, with guard removed to show bundle of hairs and lever

drum which is driven by clockwork. The instrument is compensated for temperature. The sensitive paper is changed every 48 hours, and after development the curve is measured, thus giving the hourly values of pressure.

This arrangement does not dispense with eye readings entirely but instead of hourly readings being taken throughout the 24 hours, three readings taken at say 9 h., 15 h., and 21 h., are sufficient in order to check the barograph readings. Theoretically, only corrections for latitude and height above sea-level are necessary with barograph readings. There is, however, always a slight correction to be made on account of the variations of the sensitive paper with the changes in the humidity of the atmosphere. This "residual" correction is determined from the differences between the eye readings of the standard barometer and the readings as found by the measuring machine from the developed curve

Pressure Units.—As the pressure exerted by the atmosphere is a force, it ought to be measured in units of force, either in the foot-pound second system, or in the centimetre-gramme second system. Until recently, however, the method adopted was to replace this value by that of the height of a column of liquid, e.g. mercury. In English-speaking countries the unit of length adopted was the inch and the pressure was given in so many inches of mercury, e.g. 29.925 in. On the continent the unit employed was the millimetre. On 1st January, 1914, however, the C.G.S. system of units was introduced by the meteorological services of the British Isles and of the United States of America, and France adopted the same system at the beginning of 1919. In all cases the value of gravity is the value for latitude 45°.

Under the old system the standard value of pressure was that due to a column of mercury 29.925 in. or 760 mm. high at a temperature of 273° A. and in lat. 45°. This value when expressed in the C.G.S. system represents a force of 1,013,231 dynes per square centimetre. As this number is very large and cumbersome, certain new terms have been introduced. Thus, 1,000,000 dynes per square centimetre has been called a "bar" while a thousandth part of this value is known as a "millibar". This millibar, which is $\frac{1}{1000}$ th of a bar or 1000 dynes per square centimetre, is the unit of pressure now used, and the value of the barometric reading is always expressed in millibars. The term "centibar", the value of which is

10 mb., is occasionally used. In America the terms employed are slightly different. A comparison is given below:

In Europe.		In America.		Equivalent in Absolute Units.
1 bar		1 megabar ...		1 megadyne, or 1,000,000 dynes per square centimetre. = 750.1 mm. = 29.531 in.
1 millibar (mb.)		1 kilobar (kb.)		
1 microbar ...		1 bar		1000 dynes per square centimetre.
				1 dyne per square centimetre.

In the C.G.S. system the standard atmosphere is therefore 1 megadyne per square centimetre.

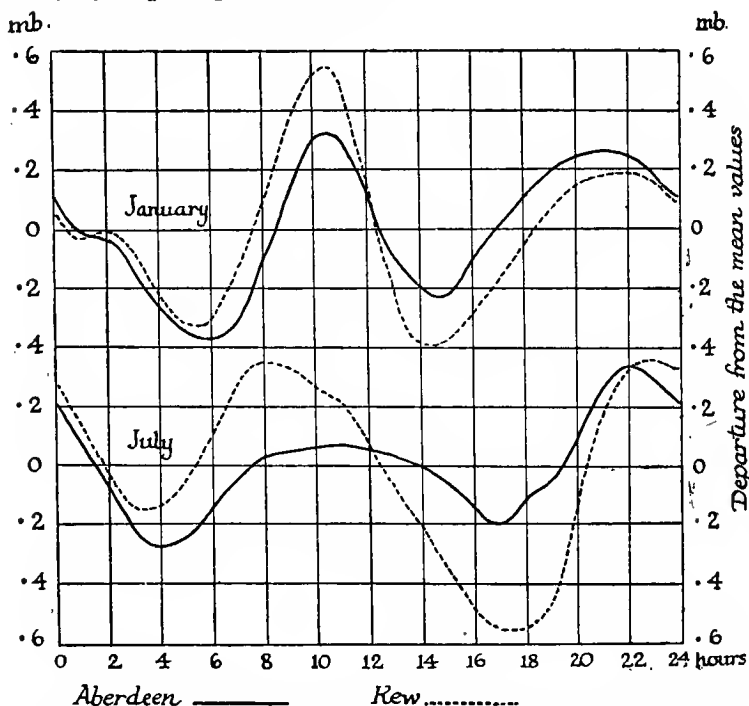

Fig. 31.—Diurnal Variation of Pressure for the months of January and July deduced from the mean values for the period 1871-1910

Aberdeen—mean value 1007.51 mb., January. Kew—mean value 1016.29 mb., January.
1009.44 „ July. 1014.30 „ July.

From this table it can be seen that it is a very simple matter to convert from millimetres to millibars; for as 750.1 mm. = 1000 mb., 1 mm. = $\frac{4}{5}$ mb. approximately, and conversely 1 mb. = $\frac{5}{4}$ mm.

Diurnal Variation of Pressure.—The regularity of the diurnal

variation of pressure in tropical countries has been already remarked upon in Chapter I, and we shall now examine more closely this diurnal variation over the surface of the globe. In equatorial countries the pressure increases steadily from 4 h. until 10 h., then decreases until 16 h. Afterwards it increases again and reaches a second maximum about 22 h., and thereafter falls until 4 h. of the following day. This daily variation is much less marked in countries in middle latitudes, and it is difficult to find a series of days on which this twelve-hourly period is shown. If, however, the hourly values for a month over a long period of years be taken, this oscillation is seen in temperate climates as indicated by the curves of fig. 31. The curves show that the night minimum and the morning maximum take place about two hours earlier in summer than in winter, whereas the afternoon minimum and the evening maximum occur later in summer than in winter, the minimum value being nearly three hours later and the maximum from one to two hours. The difference between the morning maximum and the afternoon minimum is the diurnal amplitude, and that between the evening maximum and night minimum, the nocturnal amplitude. The following table gives these values, and also the mean value for the day for the various months of the year for the two stations of Aberdeen and Kew. The figures for Kew show that the diurnal variation is larger than the nocturnal, especially during the summer months. The opposite takes place at Aberdeen, where, in every

TABLE VIII
AMPLITUDES OF BAROMETRIC OSCILLATIONS IN MILLIBARS

ABERDEEN.				KEW.		
Month.	Diurnal.	Nocturnal	Mean.	Diurnal.	Nocturnal.	Mean.
Jan.	0.54	0.64	0.59	0.93	0.54	0.74
Feb.	0.52	0.70	0.61	0.90	0.59	0.75
Mar.	0.47	0.73	0.60	1.02	0.57	0.80
April	0.32	0.89	0.61	1.05	0.62	0.84
May	0.30	0.74	0.52	1.00	0.54	0.77
June	0.35	0.57	0.46	1.01	0.46	0.74
July	0.26	0.61	0.44	0.92	0.50	0.71
Aug.	0.29	0.67	0.48	0.96	0.50	0.73
Sept.	0.44	0.70	0.57	1.01	0.58	0.80
Oct.	0.43	0.81	0.62	0.79	0.74	0.77
Nov.	0.56	0.47	0.52	0.88	0.54	0.71
Dec.	0.49	0.70	0.60	0.91	0.72	0.82

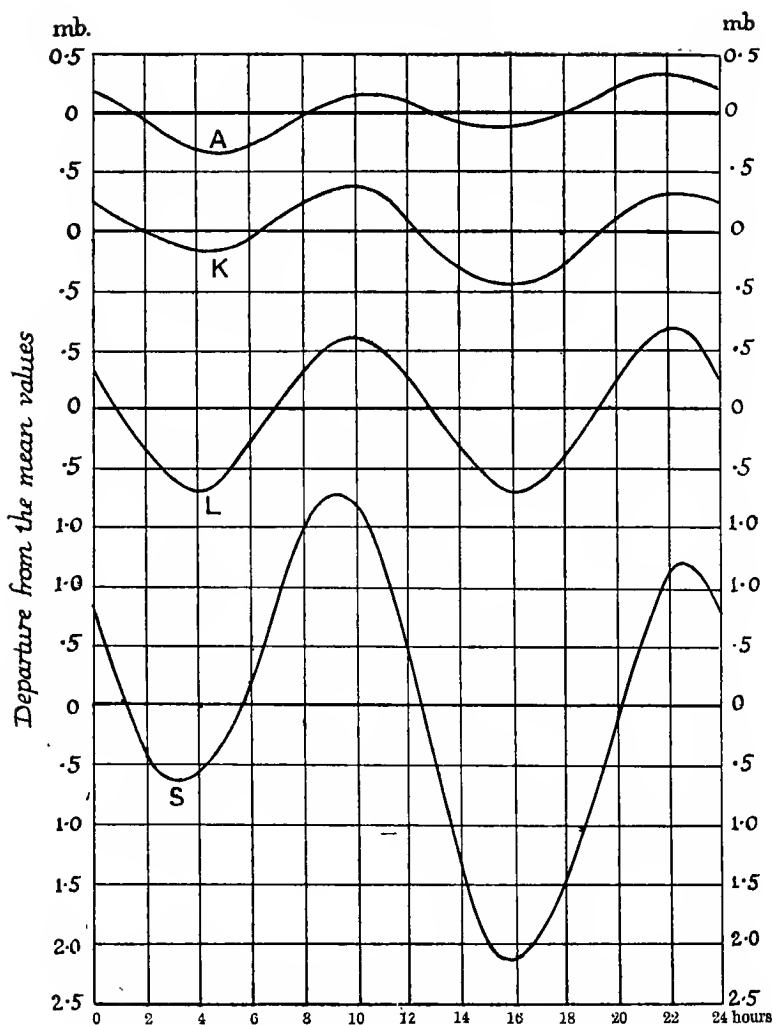

Fig. 32.—Diurnal Variation of Pressure: Effect of Latitude

S = Singapore, lat. 1° N. L = Lisbon, lat. 39° N. K = Kew, lat. 51½° N. A = Aberdeen, lat. 57° N.

month with the exception of November, the nocturnal value is the greater. This difference is especially noticeable in the summer months. For continental stations the exact opposite takes place, the nocturnal amplitude becoming very small, while the diurnal amplitude is by far the greater of the two. Kew affords an example of a station which lies between these two extremes, but where the tendency is towards the continental type.

A third oscillation is seen to take place in January, between 1 h. and 3 h., with a maximum about 2 h. The amplitude of this third oscillation is very small. It occurs only in mean latitudes and then in general only between November and April. In the Aberdeen records it can be traced from October until about the beginning of May. In tropical regions and in high latitudes it is not found at all.

Diurnal Variation in Different Latitudes.—Near the Equator the amplitude of the variation is large, but with increase in latitude the amplitude becomes smaller and smaller. Thus, the mean amplitude at Singapore is a little over 3 mb., at Lisbon it is about 1.2 mb., at Kew, 0.7 mb., at Aberdeen, 0.5 mb., and at Upsala it is

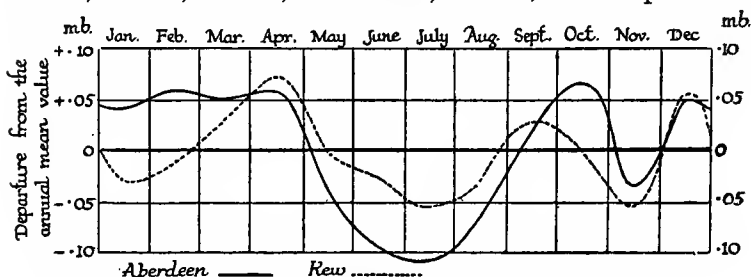

Fig. 33.—Annual Variation of the Mean Value of the Sum of the Diurnal and Nocturnal Amplitudes

Aberdeen, annual mean value = .55 mb. Kew, annual mean value = .77 mb.

only 0.4 mb. Fig. 32 shows graphically the variation in different latitudes.

Variation of the Mean Value of the Amplitude.—The mean value of the diurnal and the nocturnal amplitudes varies slightly throughout the year. Fig. 33 represents this variation for the two stations hitherto considered, viz. Aberdeen and Kew. Each shows a distinct minimum in July, and another in November. The deviation from the mean value is greater in the case of Aberdeen than in the case of Kew, while at Paris the deviation is almost negligible.¹ Records for Valencia also show a marked minimum during the months of June, July, and August. There appears, therefore, a tendency for this variation to be more marked at coastal stations than at inland stations. The amplitude of the variation, however, is small, amounting only to 0.18 mb. at Aberdeen, and 0.13 mb. at Kew (see Table VIII, p. 103).

¹ Angot: *Traité élémentaire de Météorologie*, p. 100.

Hypotheses regarding the Semi-diurnal Pressure Waves.—

Several hypotheses have been advanced regarding the cause of these semi-diurnal pressure waves, but on some points there still exists uncertainty. The variations of temperature throughout the day, together with the formation of dew at night, doubtless play a large part in causing these oscillations. If temperature alone be considered, pressure should continue increasing after the rising of the sun for a few hours, for as only the lower layer heats up at first, this layer contained between the ground and the upper cold layers will tend to exert slightly greater pressure. As convection sets in the warmer air will begin to flow off above to regions where the pressure at high altitudes is less, and so pressure should diminish during the afternoon. With the cooling in the late afternoon the air contracts, and a flow takes place towards the cooling region, causing thereby an increase of pressure, at first comparatively rapidly and then more slowly during the night. With the rising of the sun pressure would increase again. This would produce only a 24-hour oscillation. Water vapour is present in greatest quantity in the afternoon and least at sunrise, which would indicate a minimum in the afternoon and a maximum at sunrise. The variation in the time of maximum and of minimum pressure from one season to the next is small, however, compared with the variation in the time of sunrise in mean latitudes, so that the explanation of the semi-diurnal variation of pressure must be sought for in another way than by simply considering the rise and fall of temperature and humidity.

The maxima and the minima values of pressure on any given latitude in tropical and temperate regions occur at the same local time, thereby suggesting that a wave is travelling round the earth from east to west, the period of which is 12 hours. In the polar regions the maxima and minima do not occur at the same local time, but more approximately at the same Greenwich mean time. The hypothesis that a stationary wave is set up between the pole and the Equator was put forward by Schmidt¹ in 1890, and has lately been supported by Dr. Simpson² of the Indian Meteorological Service. According to this hypothesis, there are two motions each with a period of 12 hours. The one moving along the parallels of latitude has its maximum amplitude at the Equator, the amplitude

¹ Schmidt: *Met. Zs.*, Braunschweig 7, 1890, p. 182.

² Simpson: *Jour. Roy. Met. Soc.*, Vol. XLIV, p. 1.

decreasing towards the poles. The other is a vibration along the meridians in the form of a stationary wave, having a node at lat. $35^{\circ} 16'$, so that pressure increases and decreases at the same absolute time at all stations north of this latitude in the Northern Hemisphere, and changes at the same time but in the opposite sense at all stations between this latitude and the Equator. The same holds for the Southern Hemisphere. The amplitude of this vibration is greatest at the poles. The variations recorded at many stations tend to support this hypothesis of a combination of two wave motions, but as the number of stations is limited and the periods of observation in some cases short, it is impossible to say that the complete explanation of the semi-diurnal variation has been arrived at.

Annual Variation of Pressure.—There is no regular annual variation of pressure with latitude as occurs with temperature, and the only general law that can be formulated is that in mean latitudes pressure is highest in winter and lowest in summer over continental areas, and conversely over the oceans. The explanation of this is not far to seek. In the summer-time the land areas become much warmer than the ocean in the same latitude, and consequently some of the air over the heated land areas passes to the colder areas over the sea, thus causing a diminution of pressure over the land and an increase over the sea. The opposite will take place in winter, for the land is cold in comparison with the sea in the latitudes considered. There is then a continual change of air from land to sea and back again from one season to another, thereby causing an annual rise and fall of pressure. Thus at Moscow the maximum occurs in January and the minimum in June, while at the Azores in mid-Atlantic the maximum occurs in July and the minimum in November. In western Europe, which comes at one time under the influence of the continental system and at another under that of the ocean system, two maxima are observed, one in January or February and the other in June. These are separated by two minima, the first in March or April, the second in October. The following table gives the monthly averages for Aberdeen and Kew. The values are expressed in millibars.

TABLE VIII (a)
Monthly averages of pressure

	Jan.	Feb.	Mar.	Apr.	May.	June.	July.	Aug.	Sept.	Oct.	Nov.	Dec.
Aberdeen	1007·51	7·87	7·01	9·27	11·74	12·02	9·44	8·30	10·22	6·99	6·99	1004·90
Kew	1016·23	14·80	12·89	12·22	14·64	15·04	14·30	13·81	15·39	12·43	13·10	1013·13

The maxima and minima values are underlined. A third maximum is seen to occur in September, and is found also to occur at Valencia, showing thereby that on the whole, during the month of September, the British Isles are dominated by a high pressure system.

All these variations, however, are small compared with the irregular variations which take place in temperate zones. These often amount to 30 or 40 mb.

Variation of Pressure with Height.—If one considers the pressure on a horizontal plane within a heavy incompressible fluid, that pressure is equal to the weight of the fluid vertically above the area concerned. Also if the plane be placed at different depths within the fluid, the total pressure on the surface is always proportional to the depth below the free surface. With a gas such as the atmosphere, the case is different. The pressure on any given horizontal surface is always the weight of the column of air vertically above the surface, extending from it to the upper limit of the atmosphere, but the pressure is no longer directly proportional to the height of this column. As pressure decreases with height, so also will the density of the air, according to Boyle's Law.

Laplace's Law.—Laplace has deduced a law for the diminution of pressure with height in the case of still air. He showed that pressure decreased in geometrical progression as the height increased in arithmetical progression. Thus if there are two stations at which the pressures are p_0 and p , then the difference in height z between these two stations is given by the formula

$$z = 18400 A (T/T_0) \log \frac{p_0}{p},$$

where z is expressed in metres. T is the mean temperature of the layer of air between the two stations, and A^1 is a constant which is nearly equal to unity. T_0 is 273° A.

$$\begin{aligned} {}^1 A &= \left(\frac{1}{1 - k \cos 2\lambda} \right) \left(1 + \frac{z}{R} \right) \left(\frac{1}{1 - 0.378 \frac{\phi}{\eta}} \right) \\ &= (1 + k \cos 2\lambda) \left(1 + \frac{z}{R} \right) \left(1 + 0.378 \frac{\phi}{\eta} \right) \end{aligned}$$

approximately, where λ = latitude, k = constant of variation of gravity with latitude and = 0.00259; R = mean terrestrial radius; ϕ = mean pressure of aqueous vapour in the atmosphere and $\eta = \frac{p + p_0}{2}$. The term $\left(\frac{1}{1 - 0.378 \frac{\phi}{\eta}} \right)$ is the correction for the aqueous vapour in the atmosphere, and $\left(\frac{1}{1 - k \cos 2\lambda} \right)$ for the variation of gravity with latitude.

From this formula one can see that the pressure at 5540 m., or approximately $3\frac{1}{2}$ miles above the surface, is reduced to half the surface value, while at a height of 55 Km. the pressure is only about 1 mb. The height of the atmosphere therefore is very small compared with the radius of the earth, and as practically all phenomena in meteorology with which we have to deal take place in the lower layers of not more than 30 Km. in thickness, the vertical distance is very small compared with the horizontal distances on the surface of the globe over which these phenomena take place.

Reduction to Sea-level.—Before the measurements of pressure taken simultaneously at two stations can be compared, it is necessary that the values be reduced to some common level. The level generally chosen is mean sea-level, and by means of Laplace's formula all pressures can be reduced to this level. The result so obtained is the pressure that would be found vertically below the station on a plane which is on a level with the sea. As the formula involves two pressures and a height, it is necessary that the height of the station above sea-level be known. The result so obtained, however, cannot be said to be absolutely correct, as the formula involves the mean temperature of the column and the tension of aqueous vapour at the two levels. Now only the conditions of temperature and humidity at the higher level are known. The rate of increase of temperature may be assumed to be 1° A. for every 200 m., but this is only an approximation, so that there remains always some inexactness in the results. For stations below the level of 500 m. this error is not likely to be more than 0.2 or 0.3 mb., but for places above 700 m. or 900 m. the error may be considerable, and it is well to avoid it. If a number of stations be situated on a plateau, instead of reducing their values to sea-level, the best method is to reduce their values to some common level which corresponds approximately to the level of the stations.

Determination of Height.—Another use of the law is found in determining the height between two neighbouring stations. For this purpose simultaneous observations of pressure and temperature at the two places are necessary. The mean temperature is thereby found, also the ratio of the pressures and of the vapour pressures, thus enabling the difference in level between the two stations to be determined by the formula. But the air is assumed to be still in Laplace's formula, so that the results are only approximate; but if only an approximate value of the height is required, this method

is much quicker than the ordinary method of levelling. The method may be adopted very successfully for the determination of intermediate heights between two stations of which the exact height in each case is known.

The Altimeter.—Through the law of diminution of pressure with height, the pilot of an aeroplane or the commander of an airship is able by his altimeter to determine his height above the surface of the earth. Before the start the altimeter must be set at some definite reading; then as the machine ascends, the decrease in pressure is shown on the instrument, and the height above the starting-point determined. These instruments are all calibrated by being placed, along with a mercurial barometer, in a receiver from which the air is gradually pumped out. The equivalent of the air removed can then be found in feet, and the dial of the instrument graduated accordingly. Alteration of temperature with height must also be allowed for in this calibration. In using this instrument it is necessary for the pilot to know the horizontal variation of pressure, and also the rate of change of this variation at the earth's surface, and to make allowance accordingly. Otherwise the indications on the instrument would be misleading, and the pilot on descending would find himself either some distance above the ground when, according to his altimeter, he should be on the ground, or else striking the earth while his altimeter showed him some distance above it. This question will be more fully discussed in dealing with the minor circulations of the atmosphere.

For altitudes up to 1000 m. the variation of pressure with height is given with sufficient accuracy by the formula:

$$p_0 = p_0 e^{z/KT}, \text{ where } p_0 = \text{pressure at mean sea-level,}$$

$$p = \text{pressure at station level,}$$

$$z = \text{height of the station in metres,}$$

$$K = \text{constant} = 29.3,$$

$$T = \text{temperature on the absolute scale.}$$

$$\begin{aligned} \therefore p_0 - p &= p(e^{z/KT} - 1), \\ &= p(z/KT + z^2/2K^2T^2 + \dots), \\ &= \frac{pz}{KT} \left(1 + \frac{z}{2KT} + \dots \right), \\ &= p \left(\frac{z/K}{T - \frac{z}{2K}} \right) \text{ approximately.} \end{aligned}$$

A correction may be applied for temperature, for if T be the temperature at a height z , then the temperature at sea-level would

be $T + z/200$ and the mean temperature of the air column would be $T + z/400$. The formula becomes therefore:

$$p_0 - p = p \frac{z/K}{T + z/400 - z/2K}$$

The height of one station above another may also be obtained approximately in the following way: Let p_0 and p_1 be the pressures and T_0 and T_1 the temperatures on the absolute scale at the two stations.

If p_0 be written as

$$p_0 = \frac{p_0 + p_1}{2} + \frac{p_0 - p_1}{2},$$

then from

$$p_0 = p_1 e^{z/KT} \text{ or } z = KT \log \frac{p_0}{p_1},$$

where T is the mean temperature of the layer, and $T = \frac{T_0 + T_1}{2}$, we obtain

$$z = \frac{K(p_0 - p_1)(T_0 + T_1)}{p_0 + p_1},$$

where z is expressed in metres, giving the difference in level of the two stations.

A rough method of determining heights is to allow 90 ft. or $27\frac{1}{2}$ m. for every tenth of an inch, or 3.3 mb. of pressure.

Distribution of Pressure over the Surface of the Globe.—

To compare pressures at different points on the surface of the earth, it is first necessary to reduce all the values to mean sea-level (M.S.L.). When these values are plotted on a chart of the world, points are found for which the average pressure is the same, and through these points lines can be drawn. These lines are lines along which the pressure is constant, the values on one side being greater than, and those on the other side being less than, the values on the line itself. These lines of equal pressure are called "Isobars". Their position over the sea is determined by observations made on board ship.

Chart IV represents the distribution of pressure for the year, and is obtained from the mean annual values. There are several points which are at once apparent on looking at the chart.

(1) Along the Equator there is a belt of relatively low pressure of approximately 1012 mb., and in the portion north of Australia it is under 1010 mb. (2) On either side of this belt are two belts of high pressure, one round lat. 35° N., the other round lat. 30° S.

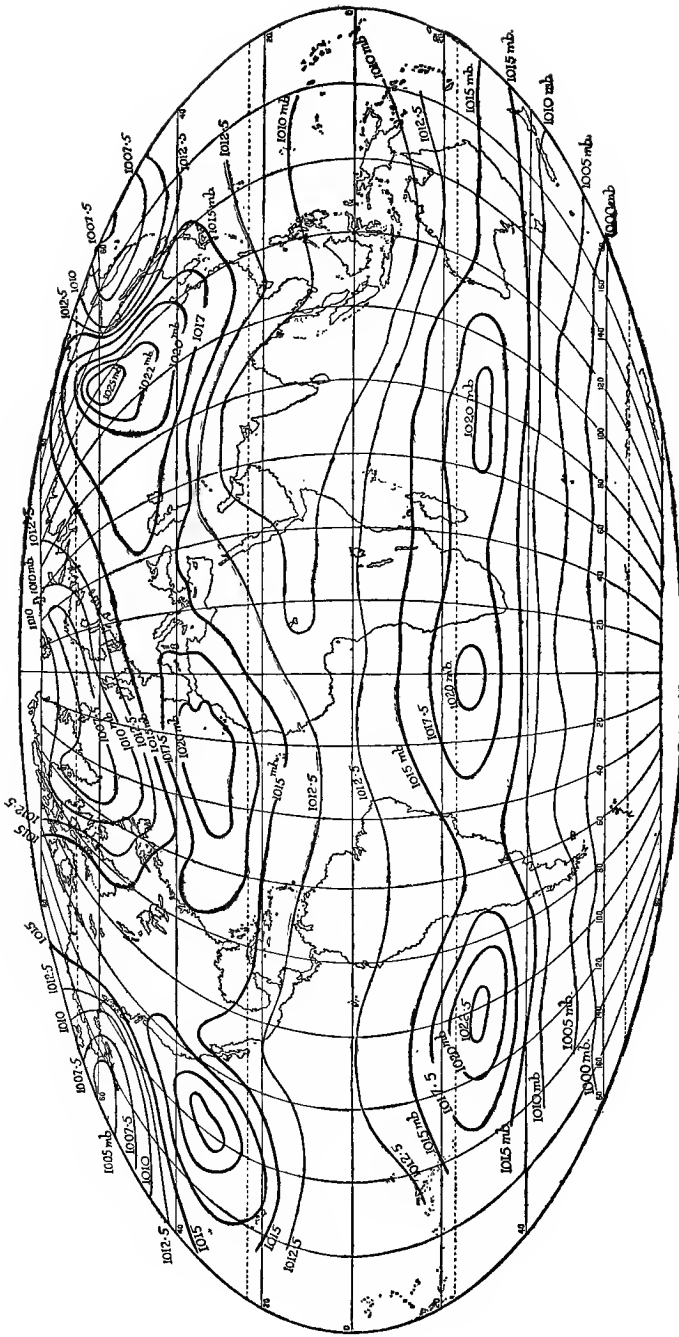

Chart IV.—Annual Isobars

These belts are not continuous, but are broken up into three separate centres each. The northern belt has one centre over the Pacific, the second over the Atlantic, and the third over Siberia, and well to the north. This centre is due to the very high pressure prevailing over Siberia during the winter months. In the southern belt the centres are over the southern Pacific, the southern Atlantic, and the Indian Oceans, and are all approximately in the same latitude. (3) Beyond these belts pressure diminishes towards both poles, regularly in the Southern Hemisphere, but irregularly in the Northern. In the Northern Hemisphere, there are two low centres, one in the northern Pacific near Alaska, the other over the northern Atlantic near Iceland, whereas in the Southern Hemisphere there is a regular decrease from the tropical belt of highs to the Pole. The great regularity of pressure in the Southern Hemisphere is especially worthy of notice. (4) Pressure decreases more rapidly from the belt of high pressure to the Pole in the Southern Hemisphere than in the Northern.

Change of Pressure Distribution with Height.—This mean distribution of pressure is valid only for the surface. At various heights above the surface the distribution becomes quite different, and it is well to bear this in mind, as these differences play a great part in the theory of the general circulation of the atmosphere. From Chart IV the mean pressure for every 10° of latitude can be read off, and the mean of the two hemispheres calculated. In the same way the mean temperatures can be found, and allowing a decrease of 1° A. for every 200 m., the pressure at different heights above the surface can be found. At 2500 m., 5000 m., and 10,000 m., these values, according to Angot, are as follows:

TABLE IX

Lat.	Surface	2500 m.	5000 m.	10,000 m.
Equator	1010.6 mb.	757.2 mb.	559.5 mb.	286.7 mb.
10°	1011.2 "	790.9 "	559.6 "	286.5 "
20°	1013.9 "	791.2 "	558.5 "	284.5 "
30°	1016.7 "	789.2 "	553.9 "	278.3 "
40°	1015.0 "	748.8 "	544.1 "	268.1 "
50°	1009.2 "	738.3 "	531.6 "	253.6 "

This table shows that, with increase of height above the earth's

surface, the pressure gradually becomes highest over the Equator, and the two maxima in lat. 35° disappear. Also pressure at 10,000 m. diminishes quite rapidly from the Equator to lat. 50° , decreasing by more than $\frac{1}{10}$ of its value within these limits.¹

Isobaric Charts for January and July.—The isobars for these months are represented by Charts V and VI, and are compiled from the mean values of pressure for these two months, the values being first reduced to M.S.L. The same characteristics are present on these charts as on the chart of annual isobars, viz. the belt of low pressure in the region of the Equator, the high pressure belts in lat. 35° N. and 30° S., the regularity of the pressure distribution in the Southern Hemisphere, and the more rapid decrease of pressure towards the Pole in the Southern Hemisphere than in the Northern.

The two charts show also the movement of the equatorial belt of low pressure. In the winter, for the Northern Hemisphere it moves a little towards the south, and in the summer advances towards the north, i.e. it follows the sun, though the angular distance through which it moves is very much smaller, in this resembling the movements of the thermal Equator. The belts of high pressure just outside the tropics behave in a similar fashion so far as the portions over the oceans are concerned.

Another feature worthy of note, especially in mean latitudes, is that in regions where the mean monthly temperature shows a relative maximum, the pressure chart shows a relative minimum, and vice versa. Thus in the Northern Hemisphere in January the mean pressure reaches 1024 mb. in central United States, and 1037 mb. in eastern Siberia respectively, the temperature for these districts being then a minimum, while in July the same regions show a maximum temperature and a minimum pressure, the mean pressure over northern India falling as low as 997 mb. The same takes place in the Southern Hemisphere, maximum pressure and minimum temperature being found over the continents in July and vice versa in January, though the variations in this hemisphere are smaller than in the Northern owing to the great predominance of the ocean areas.

¹ These calculated values in Table IX show rather greater differences between the pressure values over the Equator and those over higher latitudes than the means of the actually observed values given in Table XXI, Chapter VIII, but the same general slope of pressure from the Equator towards higher latitudes is found, though rather less intense at the heights considered.

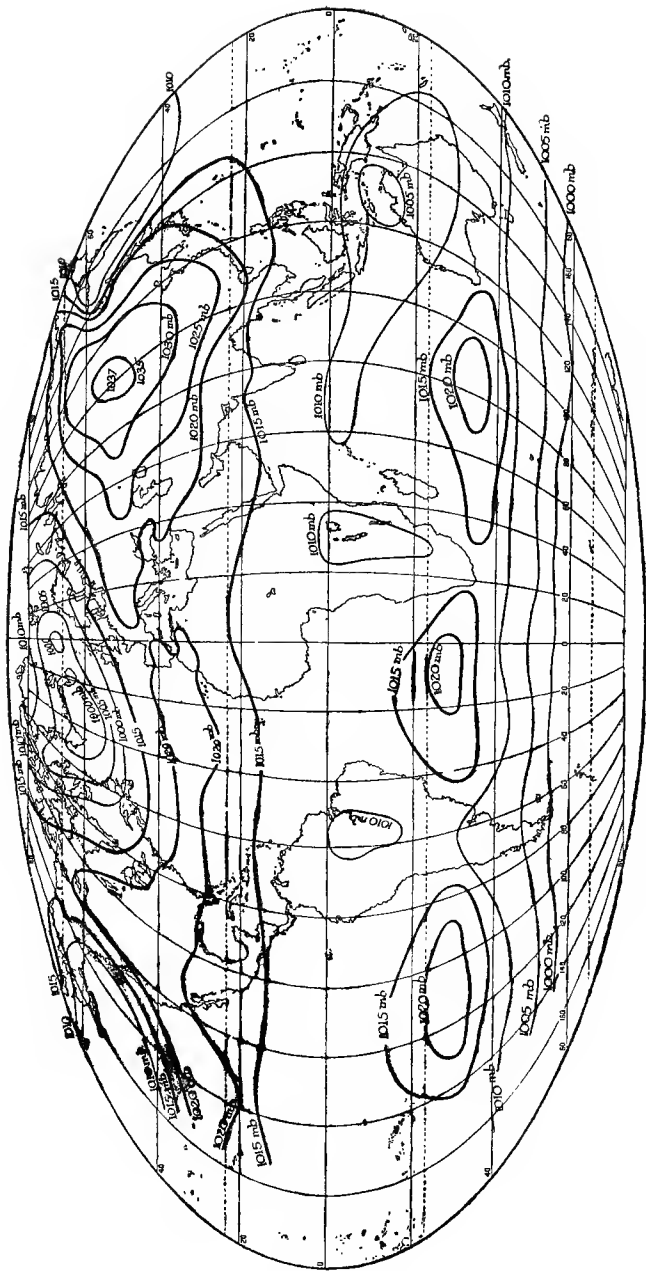

Chart V.—Isobaric Chart for January

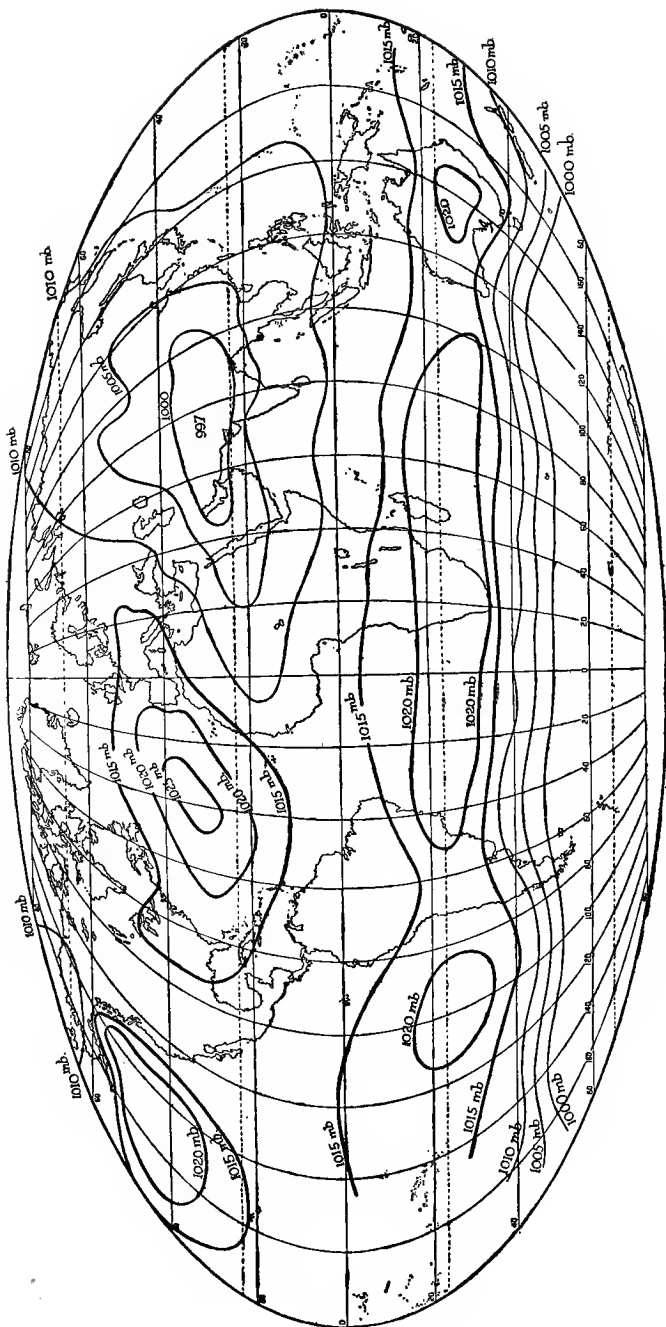

Chart VI.—Isobaric Chart for July

Law Connecting Distribution of Pressure and Temperature.—An examination of the pressure and temperature charts enables us, therefore, to arrive at the following law:

Every region where a maximum of temperature occurs, either absolute, as over the Equator, or relative compared with neighbouring regions, as in mean latitudes, shows a minimum of pressure and conversely.

In addition to the types of pressure charts mentioned, other types may be drawn where, for example, the maximum range either for the year or for the different months is set forth, likewise charts showing the frequency and magnitude of irregular variations, &c. The student will find the drawing of such charts a useful and instructive exercise.

B. THE WIND: ITS OBSERVATION AND DISTRIBUTION

Wind and Air Currents.—The wind is air in motion near the surface of the earth, and with the direction of motion nearly parallel to the earth. All other masses of air in motion should be called air currents. Thus, when a mass of air has a vertical motion as well as a horizontal motion, we call it an ascending air current and not an ascending wind.

Two things have to be considered in making an observation of the wind, velocity and direction. A third point may be added, force, but the velocity and the force are directly connected by the relation $P = CV^2$, where P = pressure or force, V = velocity, and C is a constant. When V is measured in miles per hour and P in pounds per square foot, $C = .003$. So when either P or V is known, the other is easily determined.

Direction.—The direction of the wind is the direction *from* which it blows, e.g. if the motion is from west to east then the wind is called a west wind. The direction from which the wind is blowing is called the “windward”, while the direction towards which the air is moving is called the “leeward”. As the direction of the wind seldom remains constant for any length of time, especially during the day, but oscillates about a mean position, it is generally given to 16 points of the compass. Over the ocean the wind is much steadier than over the land, owing to the absence of obstructions, and it is there possible to estimate the direction of the wind with fair accuracy to 32 points of the compass. All directions

are referred to true or geographical north, not to magnetic north, because the direction of the latter with reference to geographical north varies from country to country, and also from year to year, a slow secular change going on continuously.

The Wind Vane.—The direction of the wind is found by means of a wind vane, which ought to move with as little friction as possible. For this purpose it must be properly balanced, with the centre of gravity on the axis of rotation. It must be as light as possible in order that its momentum may be as small as possible. If the vane be heavy, then on a change of wind it tends to swing too far about its new equilibrium position. Care must be taken, however, not to sacrifice rigidity to lightness. A good exposure is essential, i.e. the vane must be above all surrounding objects, and the surrounding country should be as free from obstacles as possible. To the vane there is attached generally a vertical rod stretching down into the building on which it is placed, and to the end of the rod a pointer is attached. This pointer moves round a dial on which the points of the compass are marked, so that the direction of the wind at any moment can be read off.

The Velocity or Force of the Wind.—The force of the wind was originally estimated by the effect produced on various objects. Admiral Beaufort, in 1805, was the first to draw up a scheme showing a definite relation between the force of the wind and the effects produced.¹ This scheme or scale of wind force is known as the Beaufort scale, and is still in use. The wind force is divided into 12 groups, or 13 including calms, in this scale. Under number one are classed light airs, and under number twelve, hurricanes, very seldom experienced. Later, velocities corresponding to these various forces have been determined experimentally, but, in giving the equivalent of the Beaufort scale in miles per hour, one must be careful to state the height above ground to which the equivalents refer. The following table gives the Beaufort scale, with its equivalents in miles per hour at a height of 33 ft. above ground.

Since Beaufort's time several other wind scales have been suggested, but the Beaufort scale is the one which has been generally adopted, though there are slight differences in the equivalents accorded to the forces in different countries. At the present day, however, there are many instruments for measuring wind velocity,

¹If P = pressure in pounds per square foot, and B = the Beaufort number, then $P = .0105B^3$. This gives the further relation that $V = 1.87\sqrt{B^3}$.

TABLE X
BEAUFORT SCALE

Scale No.	Character of Wind.	Equivalent in M.P.H. at 33 ft.	Scale No.	Character of Wind.	Equivalent in M.P.H. at 33 ft.
0	Calm	< 1	7	High wind	35
1	Light air	2	8	Gale	42
2	Slight breeze ...	5	9	Strong gale	50
3	Gentle breeze ...	10	10	Whole gale	59
4	Moderate breeze	15	11	Storm	68
5	Fresh breeze ...	21	12	Hurricane	> 75
6	Strong breeze ...	27			

and though the Beaufort scale is still used to furnish an approximate idea of the wind velocity and to enable wind force to be plotted easily on a chart, yet for most purposes the velocity in miles per hour or metres per second at definite heights is employed.

Anemometers.—An instrument for measuring the velocity of the wind is called an Anemometer, as the name implies. There are various kinds of anemometers, but those in general use may be divided into three classes: pressure-plate anemometers, pressure-tube anemometers, and rotation anemometers.

Pressure-plate Anemometer.—An example of this type is the swinging-plate anemometer. It consists of an aluminium plate hinged about the top edge, and when in action the plate is set perpendicular to the direction of the wind to begin with. Thus in fig. 34 AB represents the plate with the wind blowing in the direction of the arrow. BC is a scale on which the velocity of the wind can be read in miles per hour, the scale having been first graduated by placing the instrument in a wind-channel. For heavy winds two lead bosses can be attached to the plate at the point D, when the graduations on the scale now represent winds of different velocities, according to the weight of the bosses used.

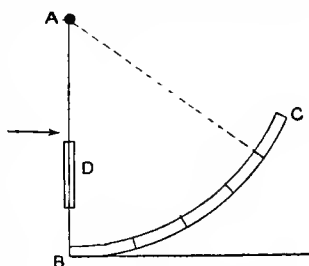

Fig. 34.—Showing Principle of Swinging-plate Anemometer

Pressure-tube Anemometer.—The type used in the British Isles is the Dines' Pressure-tube Anemometer. Fig. 35 shows

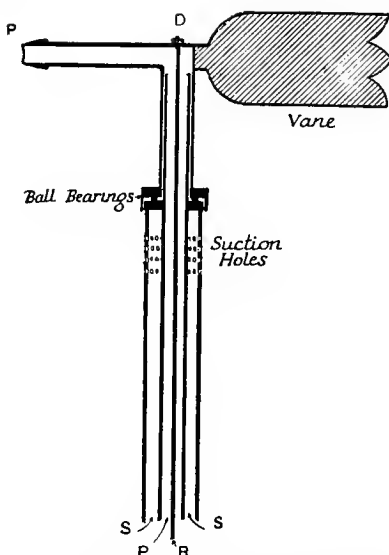

Fig. 35.—Head of Dines' Pressure-tube Anemometer

the central tube. On the outer tube near the top are four rows of perforations, and the wind blowing past these produces a diminution of pressure in the space between the two tubes, and this diminution is also transmitted to the recording portion. The head should be fixed 25 or 30 ft. above the roof of the building in which the recording apparatus is.

RECORDING APPARATUS.—This portion of the anemometer is shown in fig. 36. It consists of a float *F* inverted in a cylinder containing water. The level of this water must be kept constant, and to ensure this a gauge *G* is fixed on the side of the cylinder. To the top of the float is fixed a rod which passes through a collar,

diagrammatically the essential parts of the head of the instrument.

THE HEAD.—This part is light and is free to rotate, and the nozzle *P* is always kept facing the wind by the action of the vane. From the head two pipes, an outer and an inner, stretch down into the building in which the instrument is placed. The wind, blowing in at the nozzle *P*, produces an increase of pressure which is transmitted to the instrument below through

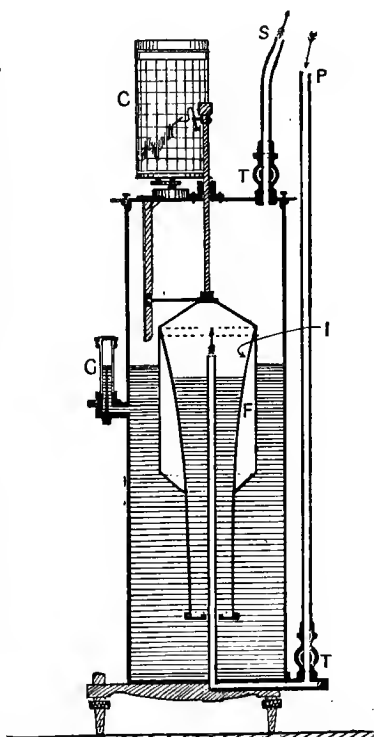

Fig. 36.—Section Diagram of Recording Apparatus of Dines' Pressure-tube Anemometer

which is practically air-tight, in the top of the cylinder. To the top of this rod is fixed the recording pen, which traces on the chart C a record of the wind velocity. The tubes P and S are the continuations of the tubes marked P and S at the head. The pressure tube enters at the bottom and passes inside the float, while the suction tube enters at the top of the cylinder. Therefore, while the effect of the one is to increase the pressure inside the float, the other diminishes the pressure in the cylinder outside it, both tending to raise the float and hence the pen.

By means of the three-way taps, T, T, communication can be made with the air of the room to allow the float to sink down to its zero position so that the pen, which is adjustable, may be brought to the zero position on the chart. The shape of the inner surface I of the float is very important, and it is so constructed that the displacement of the recording pen is proportional to the velocity of the wind at the head.

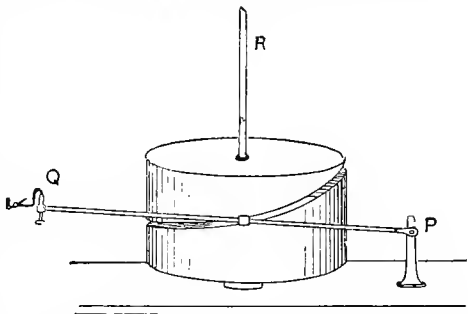

Fig. 37.—Principle of the Munro-Rooker Direction Recorder

The use of both a pressure and a suction tube eliminates the effects of changes of pressure in the room where the apparatus is.

DIRECTION RECORDER.—A direction recorder is often attached to the instrument. A stout copper wire is fixed to the top at the point D, fig. 35, and descends through the central tube as DR, passes out from the tubes at the bottom through an air-tight collar, and is fixed to the recorder which is placed on the top of the cylinder. There are two types of direction recorder used, the Dines and the Munro-Rooker. The latter is perhaps the simpler, and it is represented in fig. 37. This recorder consists of a metal cylinder with a helical groove cut around it. Into this spiral groove fits a projection from the lever PQ, the end P of which is fixed, so that when the spiral turns, the end Q moves up and down. At the end Q is attached a pen, whereby a record of the wind direction can be obtained on the same chart as the velocity record is obtained.

Rotation Anemometer.—An example of this is the Robinson Cup Anemometer. It consists essentially of two arms at right

angles, to the ends of which are attached hemispherical cups. As the pressure on the concave side of the cup is greater than on the convex, the cups rotate with the convex side foremost. Early experiments, with instruments having 3 in. cups and arms $5\frac{1}{2}$ in. long, indicated that the velocity of the centres of the cups required to be multiplied by 3 in order to obtain the velocity of the wind.

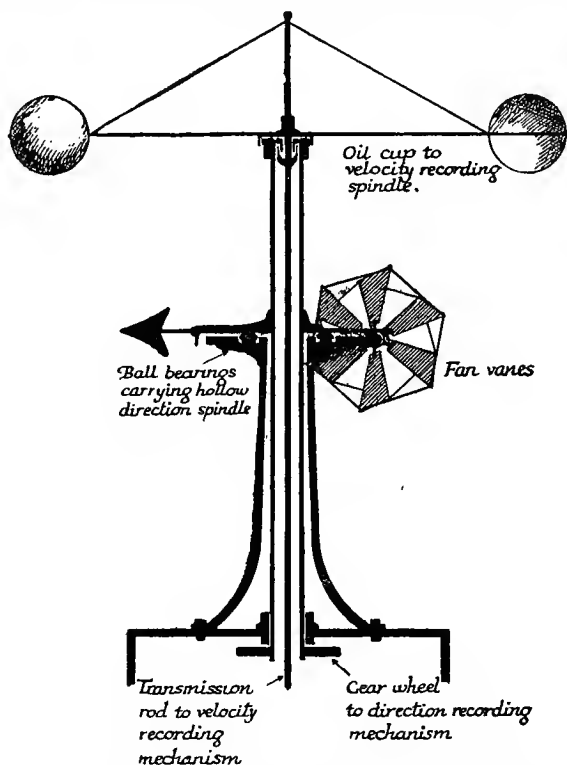

Fig. 38.—Sectional View of Robinson-Beckley Self-recording Cup Anemometer

Accordingly all instruments were made on this assumption, but later experiments with instruments where the cups were 9 in. and the arms 2 ft. long have shown that this factor was too high, especially in fresh or strong winds, the value now used being 2.2. Hence all values found by these larger instruments made according to the old factor have to be reduced in the ratio of 11 to 15.

The arms carrying the cups are attached to a vertical rod, which in turn is connected by cog wheels to a revolving brass spiral

This spiral rests on a revolving drum on which is placed a chart, so that a continuous record of the wind velocity is obtained. A direction recorder, operated by a system of fan vanes as shown in fig. 38, may also be attached, and, by a system similar to the velocity recording system, a continuous record of the direction obtained on the same chart as the velocity record is obtained.

The chief fault of the Robinson anemometer is its weight, which gives to it too great inertia. It is apt in consequence to run on when the wind suddenly falls to nearly a calm for a short time. Similarly if the wind increases rapidly it requires some time for the instrument to take up the velocity of the wind. In this way the records of sudden lulls and increases of wind are lost. Its main advantage is its simplicity and its strength.

Airmeter.—For the measurements of light winds the instrument which gives best results is the airmeter. It consists of a fan with light vanes and a dial on which the number of revolutions of the fan are recorded. From the calibration of the instrument the velocity of the wind in miles per hour can be obtained.

This instrument may also be used for finding the direction of the wind, by putting it on the centre of a plate on which the points of the compass are marked, and turning it round until the fan stops rotating. The reading found gives approximately the direction of the wind. For a more accurate determination the instrument should be turned through approximately 180° , and the new position, at which the fan stops rotating, found. The mean of these two values will give the direction of the wind.

Calculation of Wind Observations (Wind Rose).—Unlike temperature and pressure, wind direction is not a mere number, and therefore mean values cannot be calculated in the same way. Instead, the following method is adopted. The total number of wind observations over a certain period of time is taken, and divided into 8 or 16 groups according to direction. Radii are then drawn from a central point in the direction *from* which the wind is coming, and distances marked off along the radii proportional to the number of observations for the different directions. These points when joined form what is known as a Wind Rose. The following will serve as an example. The wind directions at Aberdeen observed during the month of July, 1919, can be arranged according to the following table. Calms are also included, and the

total number of observations for the month is thus 93, the observations being distributed evenly over the day.

TABLE XI

WIND DIRECTIONS AT ABERDEEN DURING JULY, 1919

Direction.	Number of Observations.	Direction.	Number of Observations.
N.	18	S.	10
N.E.	7	S.W.	3
E.	5	W.	4
S.E.	5	N.W.	33

Calms, 8. Total = 93.

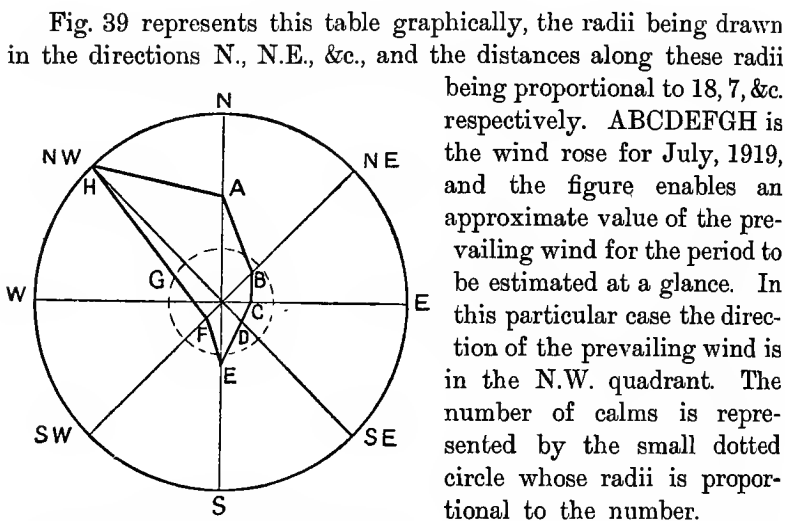

Fig. 39.—Wind Rose for July, 1919, at Aberdeen

The radius of the small dotted circle is proportional to the number of calms.

being proportional to 18, 7, &c. respectively. ABCDEFGH is the wind rose for July, 1919, and the figure enables an approximate value of the prevailing wind for the period to be estimated at a glance. In this particular case the direction of the prevailing wind is in the N.W. quadrant. The number of calms is represented by the small dotted circle whose radii is proportional to the number.

The exact direction and magnitude of the prevailing wind can be obtained in the usual way by combining the values, two at a time, by the parallelogram method, wherein the sides of the parallelogram represent in direction and magnitude the two values. The resultant so found can then be combined with the next value, and so on until the final resultant is obtained, which will give the magnitude and direction of the prevailing wind for the period.

Diurnal Variation of Wind Direction. — EXPOSURE. — The

diurnal variation of the wind direction depends very largely on the situation of the observation station. Thus if the station is near the sea or on the slopes of a mountain, local variations will entirely swamp the general diurnal variation, so that in order to obtain a true idea of the diurnal variation, it is necessary that the observation station be situated on the sea, or on a large open plain, or in the free atmosphere well above all surrounding objects.

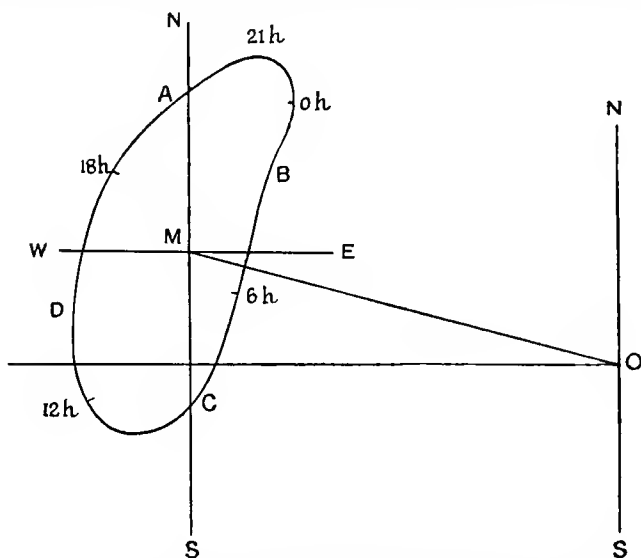

Fig. 40.—Diurnal Variation of Wind on the Eiffel Tower for the months of June, July, and August (after Angot)

A line drawn from O to any point on the curve ABCD gives the average value of the wind both in direction and in magnitude for the hour which the point chosen indicates. MO represents the mean value for the day.

This last condition is fulfilled by the station on the Eiffel Tower, which is 305 m. above the ground.

CONVECTION.—Convection helps largely to explain the diurnal variation in the wind direction, for as one ascends in the free atmosphere, the wind in general is found to veer. Consequently the air coming from the upper layers to the surface causes a veering during the day. It will have an opposite effect on the layers reached by the convection currents, the air rising from the surface retaining to a certain extent its direction, and causing thereby a backing in the upper layers. This can be seen from the Eiffel

Tower diagram, where the backing is indicated as continuing until nearly mid-day.

The wind at the surface therefore tends to veer after sunrise and to continue to do so until convection ceases. Thereafter, mainly on account of friction between the masses of air and the earth's surface, the wind begins to back and continues to do so overnight, especially if the decrease in velocity be considerable. In the upper layers, backing sets in as soon as the air currents rising from the surface reach the layer in question, and ceases only when the direction at the surface becomes the direction in the layer. Thereafter the wind begins to veer again, and in the case of the layer at the top of the Eiffel Tower the veering continues until about 21 h. For higher layers the veer would continue later in the night, just as the backing would begin later in the morning.

Diurnal Variation of Wind Velocity.—The wind velocity is a mere number, and therefore the mean values can be calculated in the same way as those for temperature and pressure. The graphs in fig. 41 are plotted from the hourly mean values of the wind velocity at Aberdeen and Kew for the months of January and July. The heights of the anemometers above the ground are 22.9 m. and 19.8 m. respectively. The means are calculated from observations for the 30 years 1881–1910.

The maximum value occurs both in summer and in winter between 12 h. and 16 h. at both stations. The minimum in summer occurs about the time of sunrise, coinciding approximately with the time of minimum temperature. In the winter, on the contrary, the minimum occurs from three to four hours before sunrise. The reason for this diurnal variation in velocity is also to be found in convection, for as the colder air descends from above to take the place of the warmer ascending air, it brings with it the higher velocities in the upper layers, thus causing the wind to increase so long as convection goes on. When convection ceases the motion of the air gradually slows down through friction, and, if the night be clear so that radiation has full play, convection practically ceases at the surface, and therefore the velocities at the surface become very much reduced, a calm frequently occurring. On the other hand the velocities in the upper layers will go on increasing for a time, for the air can absorb the long wave length radiation from the earth whereby the temperature of the upper layers

continues to rise after that at the surface has ceased. Convection, therefore, goes on above, so that the velocity in the lower of the upper layers goes on increasing beyond what it was when the surface layer reached a maximum. Fig. 40 shows this effect on the Eiffel Tower. Both direction and magnitude indicate therefore that convection is going on at that level long after it has ceased at

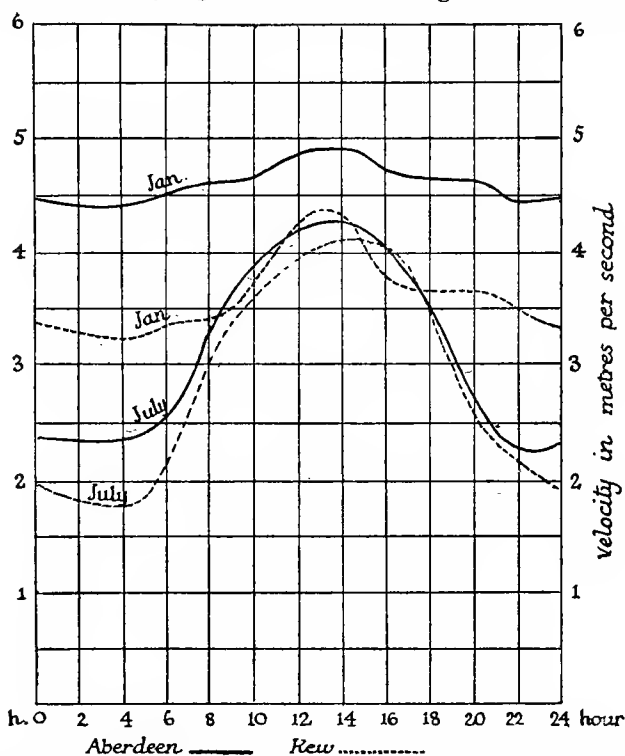

Fig. 41.—Diurnal Variation in Wind Velocity for January and July for the period 1881-1910

the surface. With the cooling at night the wind gradually decreases, but at stations on the coast, or near it, the temperature of the air ceases to fall after a time, especially in winter, owing to the proximity of the sea, i.e. convection does not cease altogether and the wind velocity remains approximately constant. This is particularly noticeable in the case of Aberdeen during January, where the variation throughout the whole day is less than 1 metre per second.

The diurnal variation has its greatest values on land, and practically disappears over the ocean. It is much less in winter than in summer, as the curves indicate, and is less in cloudy weather than in bright weather, conditions both of which are due to convection being much greater in clear weather and in summer than in dull weather and in winter.

Annual Variation in Wind.—The annual variation in the wind direction depends upon the alteration of the distribution of pressure over the surface of the globe, and therefore no definite rules can be laid down. Each locality will in consequence show a different variation. So far as velocity is concerned, the mean value in winter is greater than that in summer. For the first three months of the year the velocity tends to increase, especially at inland stations; thereafter it decreases until the month of July, and afterwards increases again. The differences, however, are small, the maximum variation at Aberdeen being only 1·4 metres per second and at Kew 1·2 metres per second. The variations at night are rather bigger while those in the day are rather less than the values given, which are the means for the day.

C. THE GENERAL CIRCULATION OF THE ATMOSPHERE

The Cause of the Wind.—If the temperature of the atmosphere were everywhere the same on the surface of the earth, then the air would have the same density everywhere at the same level, and there would be no tendency for it to move from one place to another, i.e. there would be no wind. The primary cause of the winds, therefore, is to be found in differences of temperature.

Water Analogy.—The effect of this difference of temperature can be shown by the following water analogy. In fig. 42, let AD be a long tank filled with water and divided into three sections, AB, BC, CD, and such that communication can be established at the points B, C, E, F when desired. Let these points of communication be open at first and the tank filled with air-free water to the level AD, and then communication between the compartments closed. If the centre portion be now warmed by surrounding it with, say, a steam-jacket, the water in this section will expand and rise to, say, B'C', and though now E and F be opened, no circulation will take place, because the pressure everywhere along the bottom of the tank is the same. On the contrary, if B and C be opened, since

the pressure at B and C inside the central portion is greater than the pressure on the same level in the other portions, a flow will take place from the central portion to the other two. By this addition of water to the two outside portions, the pressure at the bottom of these will be increased while that at the bottom of the central portion will be decreased. Therefore, with E and F now

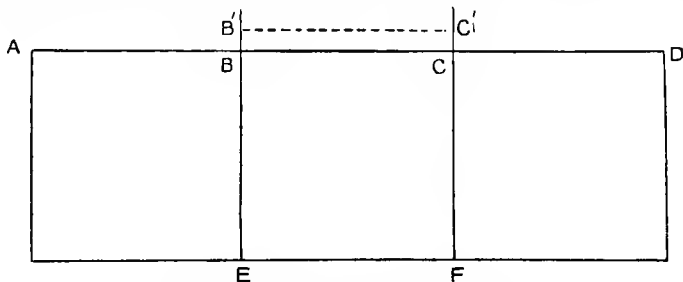

Fig. 42.—Circulation of Water caused by Warming

open, a flow will take place from the two outside portions into the centre, so that through warming the central portion a circulation can be set up.

Near the top the pressure in the central portion is greater than the pressure on the same level in the outside sections, and vice versa near the bottom, so that between these two levels there exists a

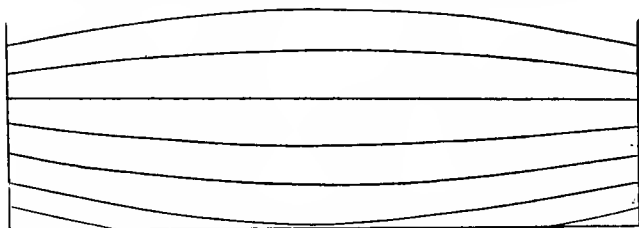

Fig. 43.—Section of Surfaces of equal Pressure within a Liquid heated over its Central Portion

plane where the pressure is the same in all three sections. This is known as the *neutral plane*. Below it the surfaces of equal pressure are lower in the central section than in the outsides, whilst above it they are higher. If then the dividing walls were removed, the surfaces of equal pressure, instead of showing a sharp break at the dividing walls, would tend to arrange themselves in curves after the manner shown in fig. 43.

If now the same methods of reasoning be applied to the problem of the atmospheric circulation, we arrive at similar conclusions.¹ For when the air becomes warmed through contact with the heated earth it expands, and a flow outwards takes place at high altitudes towards places where the air at the surface is colder. This causes increased pressure over these areas, and the difference in pressure over the cold and the hot areas causes a flow of air near the surface from the cold region to the warm. To replace this air, that over the cold regions descends towards the surface. So, while the cold air flowing into the warm air expands and ascends, further fresh supplies always flow in on the surface. Consequently the surfaces

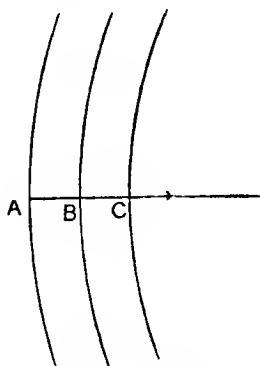

Fig. 44.—Pressure Gradient

of equal pressure or isobaric surfaces become bent in exactly the same way as in the case of the water, so that the first effect of a permanent difference of temperature between two regions is to deform the isobaric surfaces, with one exception, viz. that surface which constitutes the neutral plane. Above this plane they incline from the region above the warm area to that over the cold, and below it from the cold towards the warm. Pressures, therefore, are no longer equal in the same horizontal plane, and so the air is set in motion or winds are produced. When the isobaric surfaces become no longer parallel to the surface of the earth, as in the case considered above, they will intersect the surface of the earth in a series of lines along each of which the pressure will remain constant, but vary from line to line. These lines will therefore be isobaric lines or isobars, i.e. isobaric lines are the lines of intersection of the isobaric surfaces with the surface of the earth. The greater the horizontal temperature gradient, therefore, the more tilted the isobaric surfaces become or the closer the isobars become, and hence the greater the force of the wind. If A, B, and C, fig. 44, represent three isobars, the pressure along A being greater than the pressure along B, and hence also greater than that along C, then the direction in which pressure will decrease most rapidly will be along the normal to the curves, for the portion AB of the normal

¹ The water analogy must not be pushed too far, as the circulation of water and the circulation of air are two different problems, though they present certain similarities.

ABC is the shortest distance between the curves A and B. The difference in pressure between A and B in millibars, divided by the shortest distance between A and B, measures the *pressure gradient* over that area. In the measurement of AB the unit of length used is the length of an arc of 1° on a great circle of the earth, and is 60 nautical miles (69 imperial miles or 111.1 Km.). When the distance separating two isobars which differ by 1 mb. is greater than 60 nautical miles or 1° , the wind produced is light. Moderate winds arise when for the same distance the pressure difference is greater than 1 mb. but less than 2 mb., while for greater values of pressure differences the wind increases rapidly.

Effect of the Rotation of the Earth.—Hitherto we have considered the air as flowing directly from a place of high pressure to a place of low pressure, and, if the earth were stationary, that would take place. But the earth is revolving rapidly on its axis from west to east, making a complete revolution in one sidereal

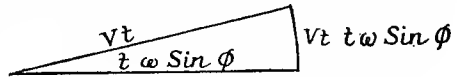

Fig. 45.—Showing the Effect of the Earth's Rotation

day, or in 86163.5 sec. of mean time, so that the velocity of a point on the Equator is very great, but diminishes to zero at the poles. A body therefore projected anywhere on the surface of the earth will maintain its original direction, but at the same time the earth will be moving out from underneath it by reason of its rotation, and so the direction observed is due to a combination of these two. If the angular velocity of the earth is ω about the polar axis, this can be resolved into 2 components, $\omega \sin \phi$ about an axis through a point where the latitude is ϕ , and $\omega \cos \phi$ about a line through the centre of the earth parallel to the tangent at the point ϕ . The latter has no effect in deviating an air current in latitude ϕ , so that we may regard the surface of the earth in that region as a flat disk with angular velocity $\omega \sin \phi$, while an air current with velocity V is passing over it. In time t this current will travel a distance Vt , and the point at which it arrives will be at a distance $Vt t \omega \sin \phi$ away from the point it would have come to had there been no rotation. The current will, therefore, appear to be displaced to the right on the Northern Hemisphere and to the left on the Southern by a distance $V\omega t^2 \sin \phi$, which, if t be taken sufficiently small, would be produced on the $\frac{1}{2}ft^2$ law, by an acceleration of $2V\omega \sin \phi$, so that the effect of the earth's rotation

is equivalent to an acceleration $2V\omega \sin \phi$ at right angles to the path.

Effect of Friction.—The force arising from friction will act in a direction opposite to the direction of motion of the air, and its magnitude for all ordinary velocities will be proportional to the velocity of the wind; but the coefficient of friction will depend on the nature of the surface over which the air is moving.

Conditions for Steady Motion.—Suppose that a particle of air originally at rest at the point A, fig. 46, begins to move towards B under the influence of the pressure gradient between A and B, the

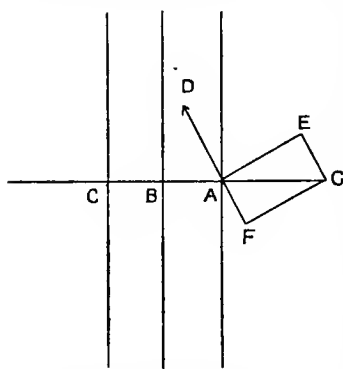

Fig. 46.—Showing Resultant Motion

rotation of the earth will tend to deflect it towards the right, and this effect will increase as the velocity increases. Similarly the force of friction, which acts in a direction opposite to the direction of motion, increases with the velocity. Hence if AE and AF represent these forces, AG will be their resultant, and when the motion is steady this force will balance the pressure gradient. The angle BAD between the direction of the wind and that of the gradient depends entirely on the ratio of AF to AE. These

for ordinary velocities are proportional to the velocity, and therefore their ratio is independent of the velocity, and varies only with the coefficient of friction. Over the sea, therefore, the angle will be large, whereas over rough country the angle between the resultant direction and the gradient will be small. The angle will also increase with latitude, though it is independent of the absolute velocity of the wind. On the other hand, the velocity is dependent on the gradient, the coefficient of friction, and the latitude. The effect of friction on the wind direction is, however, generally small, and the angle between the resultant direction and the gradient is always greater than 45° in mean latitudes, and sometimes is as large as 80° . so that the direction of the wind is approximately that of the isobars. To a first approximation, therefore, we have the relation

$$\gamma = 2\omega VD \sin \phi,$$

where γ = barometric gradient and D = density of the air. This gives an explanation of Buys Ballot's law, which is as follows:

Buys Ballot's Law.—"If you stand with your back to the wind, the region of low pressure will be on the left hand in the Northern Hemisphere and on the right hand in the Southern Hemisphere."

Cyclones and Anticyclones.—So far we have considered the case of straight isobars, but now we shall consider briefly the case where the pressure increases or decreases round a central point, i.e. where the isobars form a series of concentric circles. When the pressure decreases towards the centre, the system is termed cyclonic, whereas if the pressure increase towards the centre we have an anticyclonic¹ system.

Cyclonic System.—Fig. 47 represents a cyclonic system with pressure decreasing from A to O. A mass of air under the influence

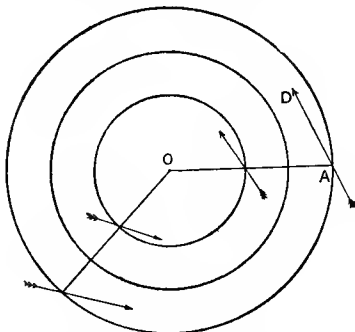

Fig. 47.—Cyclonic System

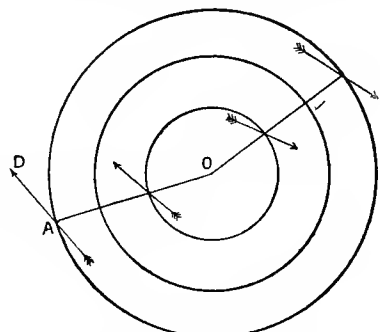

Fig. 48.—Anticyclonic System

of the pressure gradient will move in the direction AD, as we have seen above, making a definite angle with the gradient. If the conditions around the centre are everywhere absolutely identical, and if the difference in latitude between the opposite extremes of the cyclone is small, then the inclination of the wind direction to the gradient will remain constant and, therefore, the air will tend to flow in towards the centre. In the Northern Hemisphere the direction of motion will be opposite to the hands of a watch, and in the Southern Hemisphere it will be in the same sense as the hands of a watch. In such a system there is a continual flow of air in towards the centre near the ground, and as this air cannot escape at the sides near the ground it must rise up a certain distance to do so. Therefore every such system, in order to persist, must have

¹Term "anticyclone" first given by Sir F. Galton, see Chap. I, p. 8.

this ascending current. The motion is not necessarily vertical, for the depth of the layer in which the motion is taking place is small compared with its lateral dimensions, and though the inclination of the current to the ground is small, the air soon reaches the top of the disturbance.

Anticyclonic System.—In this system the pressure is highest at the centre, and the gradient is in the opposite direction. A mass of air at the point A, fig. 48, will tend to move in the direction AD, making a constant angle with the direction of the gradient if the conditions round the central point are identical on all sides. The air will, consequently, tend to flow outwards from the centre. The direction of motion in the Northern Hemisphere will be the same as that of the hands of a watch, and, in the Southern Hemisphere, the opposite. As the air is continually flowing out from the sides near the surface, this outflow must be fed from air descending from above.

These motions, both cyclonic and anticyclonic, can be produced by differences of temperature, though both systems can be produced in other ways.

General Circulation of the Atmosphere.—In Chapter I, it was pointed out how the idea of the effect of the earth's rotation on a mass of moving air slowly but surely gained ground. Hadley appears to have been the first who endeavoured to give a solution of the problem. This was in 1735. His explanation, though it contained the germs of the solution, was by no means complete, as he dealt only with north and south winds, and with these in an incomplete way. Thus, his explanation of the north-east trade winds was that these winds, blowing from a higher latitude to a lower, were passing over a belt of the earth where the west to east velocity of the surface was continually increasing, and, as the winds retained their original west-east velocity, the result was that they blew not from north but from north-east. On this theory there ought to be no effect on west-east winds. Also, as the wind approached the Equator, its velocity should increase. Both these conclusions find no support in observation, for the earth's rotation influences air masses moving in any direction, and the velocity of the wind does not continually increase as the Equator is approached.

Circulation according to Ferrel.—In the beginning of the nineteenth century, Dove gave a theory of the general wind circulation, and another was given by Maury in 1855. The problem was

also attacked by Ferrel, and in 1856 he published his first solution. This he modified slightly in 1860. In 1889, nearly thirty years later, he published a third solution, wherein he modified the systems of circulation given in the first two solutions. The circulation in this third solution is represented in fig. 49. Ferrel's solution was

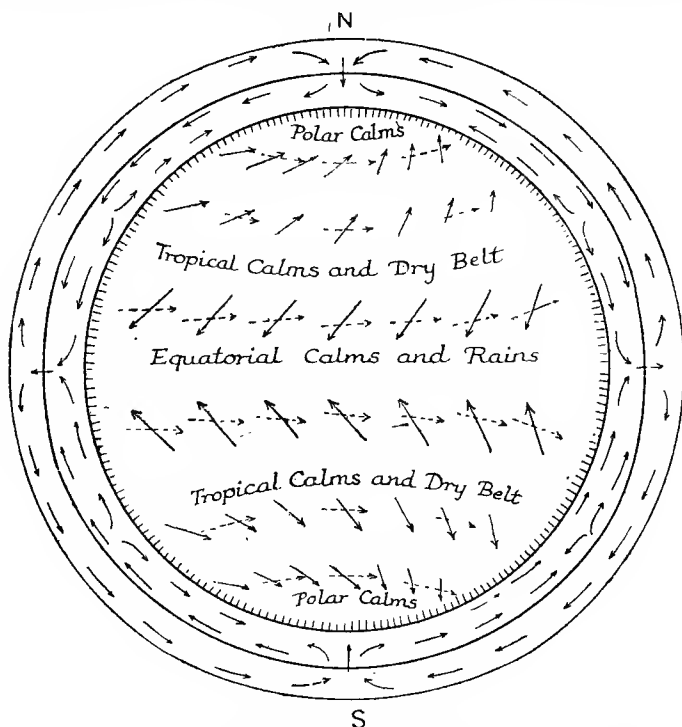

Fig. 49.—Diagram showing Circulation of the Atmosphere according to Ferrel, 1889

entirely a theoretical solution, and his theory of the atmospheric circulation was the generally accepted theory for some time.

Hildebrandsson and de Bort.—Near the end of the nineteenth century an elaborate investigation was carried out by Hildebrandsson and de Bort on cloud observations, made for many years at stations all over the world. This was augmented by observations made with *ballons-sondes* at various stations. As a result of their investigations, which were based entirely on observations, they were able to disprove certain parts of Ferrel's theory, and reduced the atmos-

pheric circulation to a more simple form than had hitherto been expected.¹ According to them there are on each hemisphere two main circulations, one between the Equator and the belt of high pressure near lat. 30°, and one between this high-pressure belt and the pole.

1. The Circulation between the Equator and the High-pressure Belt.—On the surface at the Equator is a region of calms, while, between the high-pressure belt and this belt of calms are found the trade winds, north-east in the Northern Hemisphere, south-east in the Southern.

Above the Equatorial belt of calms a current from the east exists throughout the whole year, having a velocity increasing with height. Over the trade winds are found currents from the south-west in the Northern Hemisphere, and from north-west in the Southern. These are known as the anti-trades, and, as they move farther from the Equator, they are deviated more and more to the right in the Northern Hemisphere, and to the left in the Southern, until they become currents from the west over the high-pressure belts, where they descend to feed the trade winds.

The belt of calms at the Equator moves north and south according to the season, so that in the layers above the region which is at one period in the trades and at another in the equatorial belt of calms, a monsoon exists, the direction of the current being at one time south-west or north-west when over the trades, according to the hemisphere, and at another time east when over the equatorial calms.

2. The Circulation between the Poles and the High-pressure Belts.—Pressure diminishes in the mean from the high-pressure regions to the poles, and the air of the temperate zones is drawn into a vast polar circulation turning from west to east, the whole motion appearing of the same nature as that in an ordinary cyclone. The air in the lower layers approaches the centre and that in the layers above flows out from the centre, the component velocity away from the centre increasing with height, as far up as observations have been made. The general direction on the surface in the Northern Hemisphere is south-west. In the upper layers this direction changes, first, to west, and higher up it has a northerly component. These upper layers descend on the polar side of the belt of high pressure to feed south-west surface currents. In the Southern Hemisphere a similar system exists.

¹ *Les Bases de la Météorologie Dynamique*, Hildebrandsson et de Bort.

Irregularities at the earth's surface, such as the monsoons of Asia, are found to disappear in general at the height of the lower or intermediate clouds.

Fig. 50 represents the circulations at the surface and in the upper layers.

Let us consider now how the circulation above described is caused by the unequal heating of the atmosphere, and the rotation of the earth.

If the sun remained vertically over the Equator, and if the surface of the earth were uniform and possessed no motion, there would be a belt of maximum temperature round the Equator, and, in consequence, a belt of low pressure near the surface with a current of ascending air in this region. At the poles pressure would be a maximum, and these regions would be regions of descending air. Under these conditions there would be a current of air at the surface moving towards the Equator from the poles, and another in the upper atmosphere diverging from the Equator and flowing towards the poles. Areas of calm would prevail in the regions of ascending and descending air.

But other factors, such as the rotation of the earth, the motion of the thermal Equator, and the difference in behaviour of land and water towards solar radiation, must be taken into account. When this is done a considerably modified system results.

Cause of the Easterly Current.—The air at the Equator is motionless with regard to the surface of the earth, and therefore possesses at the surface a velocity equal to the velocity of the earth's surface. In this region the air is ascending, and as it ascends it retains its original linear velocity. But it is now farther from the centre of the earth, and so its angular velocity is less. Thus it is left behind by the surface of the earth, or, by reason of the earth's rotation, this ascending air gives rise to a current from the east over the equatorial belt of calms, the velocity of which increases with height. This does not afford a complete solution of the problem, however, as the velocity so obtained would be much smaller than the actually observed velocity. Further investigation is necessary therefore before a complete solution of this problem can be obtained.

Cause of the Trades and Anti-trades.—Beyond the immediate neighbourhood of the Equator the air in the upper atmosphere is deviated towards the right in the Northern Hemisphere and towards the left in the Southern, producing thereby a south-west and north-

west current in the respective hemispheres. On the surface, for the same reason, the currents flowing towards the Equator approach

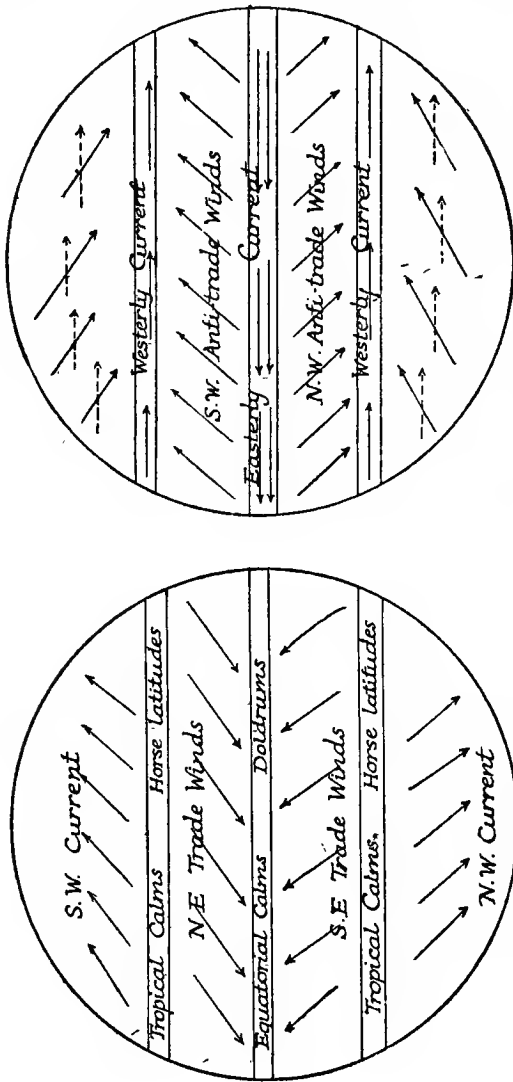

Circulation in the Higher Layers. Horizontal dotted lines represent air currents in the intermediate layers

Circulation near the Surface

Fig. 50

from the north-east and south-east respectively. These surface currents are the "trade winds", and the opposing currents above them the "anti-trade winds".

Cause of the Monsoon Effect above the Tropics.—As the thermal Equator moves north and south with the seasons, the belt of calms moves with it. This movement causes the current from the east in the upper layers to invade first one hemisphere and then the other, whereby there is a monsoon effect in these upper layers, the current during one part of the year coming from the east and during the other from the south-west or north-west according to the hemisphere.

Cause of the Prevailing Westerlies.—The air flowing out from equatorial regions does not pass directly to the poles, for as it moves polewards the centrifugal force on it increases as the radius of rotation diminishes. In this way if there were no friction the poles would be nearly devoid of air, the whole becoming heaped up in mean latitudes. This gives rise to the belts of high pressure in lat. 30° to 35° . The anti-trade winds therefore, on reaching lat. 30° , descend towards the surface and feed the trades, while the atmosphere on the polar side of the high-pressure belt is, on each hemisphere, drawn into a large cyclonic whirl round each pole.

There are thus two influences at work, a thermal and a dynamical. In the tropical regions the thermal influence predominates, producing over the Equator a minimum of pressure at the surface, but relatively higher pressures on planes at greater heights. The dynamical influence increases with latitude and diminishes the pressure at all heights, thus reinforcing the thermal effect in the upper layers. In the lower layers it replaces by a minimum of pressure the maximum which the thermal effect alone would produce. Thus a maximum of pressure is produced at the surface in lat. 30° to 35° , and a minimum in the neighbourhood of each pole. In the portions of the atmosphere on the polar sides of the belts of high pressure the dynamical effect predominates, and the whole circulation is similar to that in an ordinary cyclone, the air flowing in spirally towards the centre on the surface, and flowing out spirally in the upper layers to descend to the surface in the high-pressure regions just outside the tropics.

Doldrums and Horse Latitudes.—In the regions of maximum and minimum pressure, where the horizontal pressure gradient becomes zero, the only motion near the surface is an ascending or descending one. Consequently there is a belt of calms at each of the high-pressure regions and another at the Equator. The belt of

calms at the Equator is known as the Doldrums, while the belts in the high-pressure regions are called the Horse Latitudes.

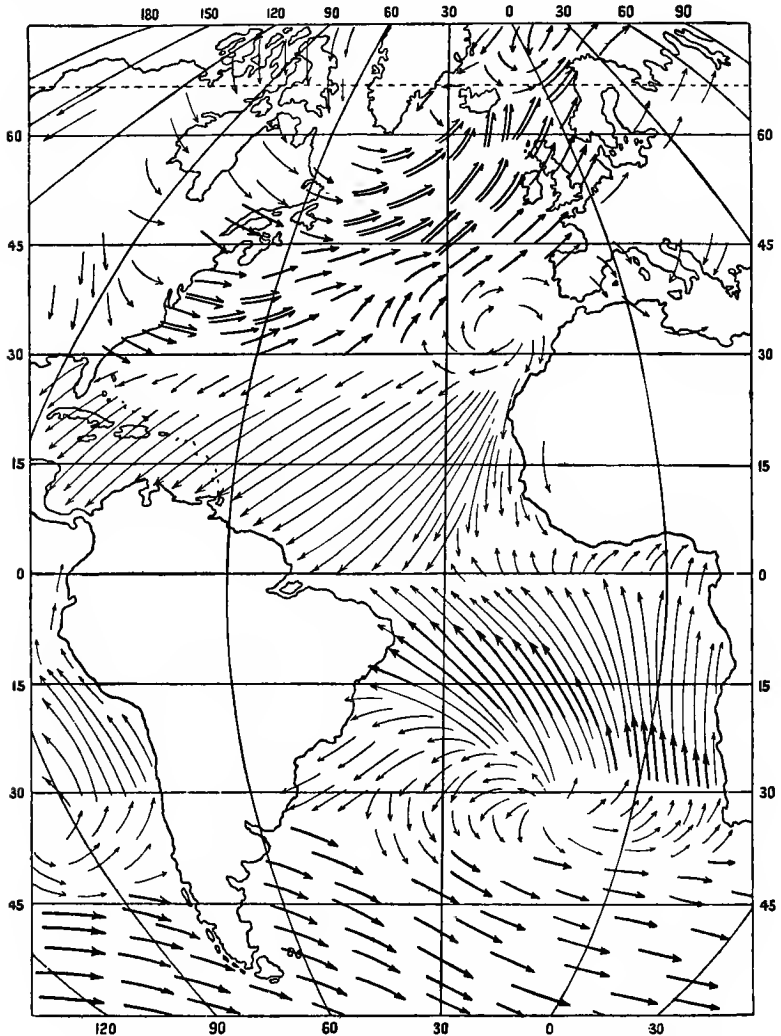

Chart VII.—Wind Circulation over the Atlantic for January-February (after Angot)

Circulation over the Atlantic: Trades and Anti-trades.—The surface of the earth is not uniform, as we have hitherto supposed it to be, and the general circulation is considerably modified, particularly in the Northern Hemisphere, by the difference in behaviour of

sea and land towards solar radiation. This is farther modified in the temperate zone by the formation of cyclones. Up to lat. 45°

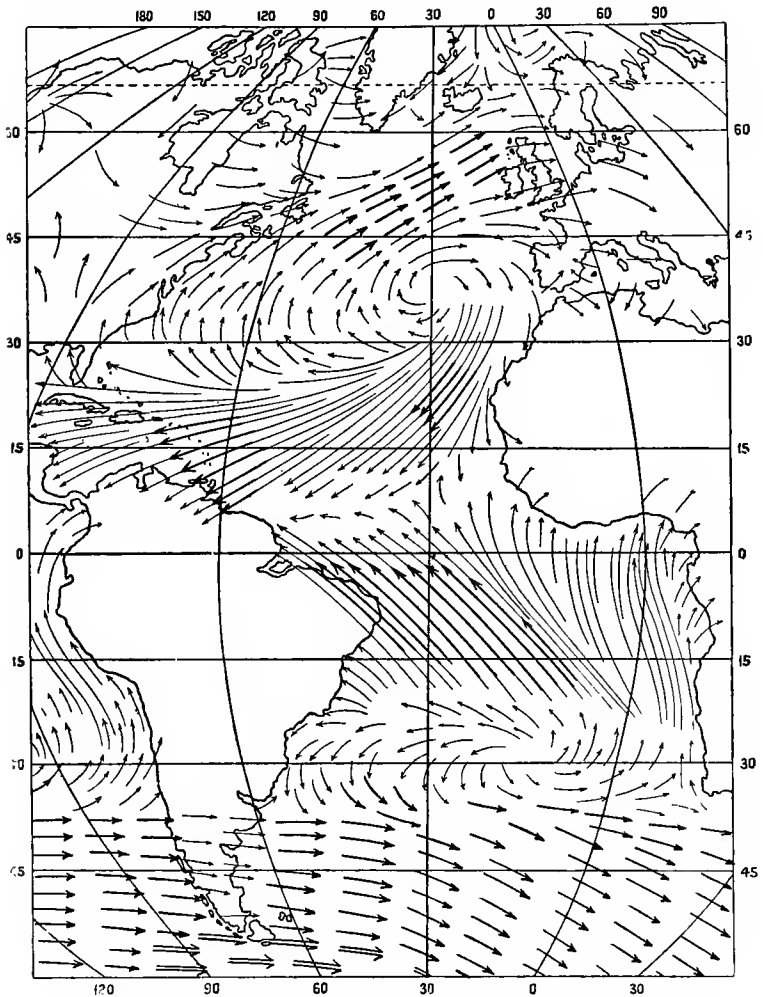

Chart VIII.—Wind Circulation over the Atlantic for July–August (after Angot)

the mean temperature of the land is greater than that of the sea, and therefore the land areas in this region become centres of relatively low pressure, so that the belts of high pressure in lat. 30° to 35° become broken up on passing over the continents of America,

Africa, and Asia, relative minima occurring in these regions, with a corresponding increase in pressure over the oceans in the same latitudes. Anti-cyclonic motion therefore takes place round these centres. In the centre there is a large area of calms. This circulation is shown in Charts VII and VIII, which give the wind currents on the Atlantic for January–February and July–August. The light arrows indicate a moderate wind; the heavy, a strong wind; and the double arrows, a violent wind. The long arrows indicate winds steady in direction; the short, winds having a less steady direction. The constancy of the trade winds is shown, and also that of the south-westerly and north-westerly winds on the polar sides of the high-pressure belts, often called on that account the “prevailing westerlies”. On account of the large amount of ocean area on the Southern Hemisphere, the prevailing westerlies are much more constant than in the Northern Hemisphere. In the Southern Hemisphere they are called the “roaring forties”, on account of the latitude in which they occur.

As the thermal Equator is always found to the north of the geographical Equator, the belt of the equatorial calms is found centred north of the Equator on the Atlantic even in winter, and the position of this belt varies with the seasons, moving north in summer and south in winter. It therefore inundates the trade winds on their equatorial side, the equatorial limits of the trade winds advancing and retiring with the seasons. On the Atlantic the limits of the trade winds and the equatorial belt of calms are as follows:—

	Limit.		Winter.		Summer.
N.-E. Trade Winds	{ Upper Limit	26° N.	35° N.
	{ Lower ”	3° N.	11° N.
Equatorial Calms	{ Upper ”	0° N.	3° N.
	{ Lower ”	25° S.	25° S.
S.-E. Trade Winds	{ Upper ”	25° S.	25° S.
	{ Lower ”	25° S.	25° S.

This shows that the trade winds stretch from near the Equator up to nearly 30° on either side of it, and so cover almost a half of the globe. Their importance therefore in the general circulation on the globe is very great.

The existence of the south-west current above the trades, i.e. the anti-trades, has been established by cloud observations and by observations of smoke from volcanoes, in the same way as the easterly current over the Equator has been observed. The eruption

of Krakatoa in August, 1883, afforded a unique chance of studying this current, dust from the eruption being carried right round the world by it. The height of the dividing region between the trades and the anti-trades varies with place and time, being in some instances as low as 4 Km. and in others as high as 10 Km.

Monsoons.—The trade winds blow in the same direction all the year round, but in the case of the monsoons they blow for one half of the year in one direction and for the other half in the other direction. With increase in distance from the Equator, the mean temperature of the ocean gradually approaches that of the land and then surpasses it, especially so in winter. Thus the oceans become warm centres in winter or centres of relatively low pressure, and cold centres in summer or centres of relatively high pressure. The circulation round these centres changes therefore from summer to winter, and there is produced these seasonal winds known as the monsoons. If the difference in temperature between summer and winter is small, the general circulation will be only slightly modified, the velocity increasing and decreasing with the seasons, but the direction remaining nearly constant. But with large differences of temperature an entire reversal of the wind direction takes place. The best example is afforded by the monsoons over Asia, where the temperature falls very low in winter. Through this fall of temperature there is a considerable rise of pressure, and on the south-eastern side of this high-pressure area there arises a strong north-east current. This is the north-east monsoon and it blows over the China Sea, Cochin-China, and the Indian Ocean. Its effect is so great that the trades are carried right across the Equator. In summer the temperature over Asia rises very much, and the region becomes a low-pressure centre, with a cyclonic circulation round it. The winds converge from all sides, and over the Indian Ocean the wind blows strongly from the south-west, i.e. the south-west monsoon. The strength of this south-west monsoon is such as to draw the south-east trade winds right across the Equator, where they deviate towards the right, forming thereby a continuous current with the south-west monsoons, while the belt of calms disappears.

Though less marked, monsoons occur over Australia and over Spain, also over the south-eastern states of America. But as their strength depends on the differences of temperature, the continent of Asia and the Indian Ocean afford the best geographical combination for their production.

Land and Sea Breezes.—The monsoons are seasonal winds, changing regularly every six months, and owe their origin to the differences in temperature over land and sea. The same thing takes place daily, but in a much less degree, as shown by land and sea breezes.

During the night the air over the land becomes colder than that over the sea, and pressure over the land rises through air flowing in above from the sea, so that the isobaric surfaces incline from the land to the sea, causing a flow of air seawards. Over the sea the air ascends, and above the neutral plane more air flows towards the land and descends again. The outflowing current from the land to

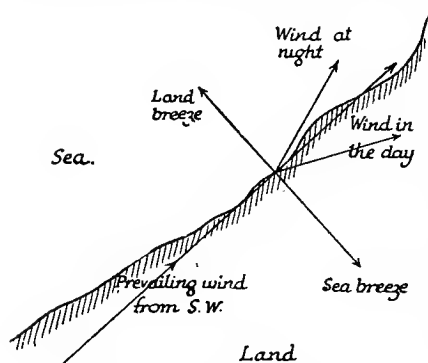

Fig. 51.—Effect of Land and Sea Breeze

the sea produces therefore the "land breeze". With the heating of the land during the day conditions become reversed, the isobaric surfaces now inclining from the sea towards the land. The warm air over the land rises, and flows out above, thereby causing increased pressure over the sea and a flow of air landwards. This flow constitutes the "sea breeze".

The direction of these winds is nearly perpendicular to the direction of the coast-line, and they last only for a few hours. The velocity and the regularity of the sea breeze are much more marked than is the case with the land breeze. These currents are generally quite shallow, often reaching to about 1000 ft. only. Their velocity is small and they seldom penetrate far on either side of the coast-line, the phenomenon being confined to an area of not more than 10 miles on either side of the coast-line. In tropical regions they are more marked than elsewhere, and on the west coast of Africa they are particularly marked by reason of the large differences of temperature. They may to a certain extent influence the general wind. If the general wind is blowing towards the coast, then the land breeze of the night tends to diminish it, while the sea breeze of the day strengthens it. If, on the other hand, the general wind is along the coast, then in the night-time, when the land breeze is acting, the wind appears to blow from the land, the

direction making an angle with the coast-line. In the day-time the direction is inclined from the sea, the two effects being shown in fig. 51. The phenomenon is well marked on the coast of Belgium.

Mountain and Valley Winds.—The diurnal variation in temperature also produces variations in the wind direction in hilly countries. As the temperature of the air begins to rise, then the air begins to ascend the hill-sides, and increases in velocity until the period of maximum temperature is reached. Thereafter the velocity gradually falls to zero and then increases in the opposite direction, the air flowing down from the mountain-tops into the valleys at night.

The cause of these winds is two-fold. Under the influence

of the sun's rays the air expands, and the isobaric surfaces are no longer horizontal. The amount of expansion of the air column is proportional to its length, and so the point B, in fig. 52, originally at the same level as A, will be raised higher than A, causing a gradient from B' to A. Also A is on the surface, and the air at A will be more heated than the air at B, which is in the free atmosphere, and will therefore become lighter.

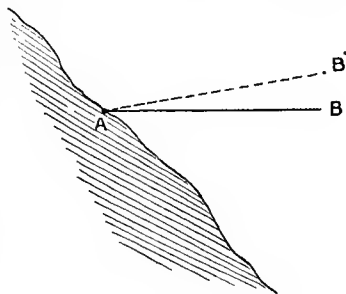

Fig. 52.—Heating Effect in a Valley

Both of these conditions tend to cause a flow of air up the mountain-side. When cooling sets in, the conditions are reversed. These winds often reach high velocities, as, for example, in long straight narrow valleys, and are generally more marked in the night than during the day. These winds rushing down from the mountains are sometimes called Katabatic winds, though this term is also applied to winds such as the Bora. This and other winds connected with the minor circulations of the atmosphere will be dealt with later.

This hill and valley effect is found in slightly undulating country, though in a much less degree. There the flow of air from the ridges down into the valleys is clearly marked, especially on clear nights, when the general wind is light. This fact must be very carefully borne in mind when it is desired to discharge gas or smoke in any given direction.

CHAPTER VI

Water Vapour in the Atmosphere

A.—EVAPORATION AND HUMIDITY

Evaporation.—In the atmosphere there is always present a certain amount of water vapour, and this amount varies from minute quantities to a maximum of not more than 4 per cent by volume of the atmosphere, even in tropical regions. In the gaseous form it is invisible, and the process of change from the solid or liquid state to this invisible gaseous form is called evaporation.

Sources of Water Vapour in the Atmosphere.—The water vapour present in the atmosphere comes from various sources, the chief source being the waters of the ocean, for three-quarters of the surface of the globe is covered by sea. Rivers, lakes, snow-clad mountains, and moist soil, vegetation, and living animals, all supply moisture to the atmosphere. Water vapour is lighter than air in the proportion of 62 to 100, so that air containing water vapour is lighter than dry air.

Rate of Evaporation.—The rate of evaporation depends very largely on the nature of the surface from which the evaporation is taking place. Thus evaporation takes place more rapidly from a surface covered with vegetation than from a free water surface, other things being equal. Other factors affecting the rate of evaporation are pressure, temperature, wind velocity, and the condition of the air as regards the amount of water vapour already in it. High pressure and a large amount of water vapour present in the atmosphere both retard the rate of evaporation, while high temperature and high wind velocity favour the process.

The Standard Surface: Evaporimeters.—As different surfaces give different results, the surface employed as standard is a water surface. For this purpose water is placed in large tanks in the open. These tanks should be about 6 ft. square and at least

2 ft. deep, so that the mass of water may not become heated up above the temperature of the surrounding air. To further ensure this condition, the tanks are sunk in the ground, their upper edge projecting about $1\frac{1}{2}$ in. above the surface. These tanks are called "evaporimeters".

At first the tank is filled to within $2\frac{1}{2}$ in. of the top. The amount evaporated in any given time can then be determined by measuring the depth of the water below the top edge at the beginning and end of the time, and therefore the amount evaporated per unit area can be determined. If shallow pans be used, too high values will be obtained, as the water becomes warmed considerably above the temperature of the surrounding atmosphere.

Humidity.—When the water passes into the atmosphere in the state of vapour, it is distributed throughout the atmosphere either by diffusion, by convection, or by the effect of the winds. The amount of water vapour present in the atmosphere is therefore continually varying from place to place, and from time to time, and the amount that a given quantity of air can contain depends almost entirely on the temperature of the air at the time. When the air contains all the vapour that it can hold at any given temperature, then the air is said to be saturated at that temperature, or to have reached the saturation point. If the temperature be raised, it will no longer be saturated. Thus if a volume of air containing water vapour be taken and the temperature gradually lowered, then a point will be reached where the air is saturated. The temperature so found is called the temperature of the dew point, or simply the dew point. Any lowering of the temperature below this value causes some of the water vapour to be precipitated in the form of dew, fog, cloud, or precipitation.

Absolute Humidity.—There are several ways whereby the quantity of water vapour present in the atmosphere at any given time may be indicated. The weight in grammes per cubic metre, or grains per cubic foot might be given, in which case the Absolute Humidity of the atmosphere would be determined. This method, though apparently simple, is unsuited for meteorology, because the time taken to obtain the value is too long and because the amount of water vapour present is continually varying with the temperature.

Relative Humidity.—Water vapour, as a gas, exerts a certain pressure, and if, from an enclosed space filled with moist air, the

water vapour be removed by phosphorous pentoxide, then the pressure in the space is diminished. This diminution of pressure varies according to the amount of water vapour originally present in the space, so that the quantity of water vapour present in a definite volume of air can be represented by the pressure which it can exert. This elastic force, or pressure, is a measure of the absolute humidity of the atmosphere, and may be expressed in inches or millimetres of mercury or in absolute units. Let this force be represented by f , and that when the air is saturated, so that the force has reached a maximum for the temperature under consideration, by F . The ratio f to F is then called the Relative Humidity. Now f and F are proportional to the absolute amounts¹ of water vapour present, and so the relative humidity is the ratio of the amount of aqueous vapour actually present in the atmosphere to the amount the air could contain at the temperature considered. If E represent this value,

$$E = f/F,$$

i.e. the relative humidity is expressed by the ratio of the pressures, and so this value would always be a fraction. In meteorology the percentage value of the relative humidity is always used, i.e. this fraction is multiplied by 100, so that if e express this percentage,

$$e = 100E = 100f/F.$$

As already stated, the amount of water vapour present in the atmosphere is always small, and the ratio of its weight to the weight of air containing it can easily be calculated. If W' denote the total weight of air per cubic metre, h the total pressure, and p the pressure of the aqueous vapour, the temperature of the air being θ on the absolute scale of temperature, then:

$$W' = \frac{1276 \times (h - \frac{3}{8}p)}{1000} \times \frac{273}{\theta},$$

while the weight of the aqueous vapour in the mixture is

$$w = \frac{1276 \times 0.623 \times f}{1000} \times \frac{273}{\theta}.$$

$$\therefore \text{the ratio} = \frac{w}{W'} = \frac{0.623f}{h - \frac{3}{8}f}$$

¹ A relation between the pressure and weight of the aqueous vapour is given by $w = \frac{1276 \times 0.623 \times f \times 273}{1000 \times \theta}$, where w = weight in grammes per cubic metre, and f is the pressure in millibars.

is a number which is always small, seldom reaching 0.05 and often less than 0.02.

Hygrometry and Hygrometers.—The study of the water vapour present in the atmosphere is termed Hygrometry, and instruments for determining either the absolute or the relative humidity are called Hygrometers. Hygrometers may be divided into two classes: those whereby the absolute humidity may be determined, and those whereby the relative humidity may be found. An example of the first type is the chemical hygrometer.

THE CHEMICAL HYGROMETER.—This instrument consists of a succession of U-tubes, some filled with pumice-stone moistened with sulphuric acid and others containing phosphorous pentoxide. When air is drawn through these tubes, the moisture is absorbed, and by weighing the tubes before and after the experiment, the amount of moisture present in a given volume of air can be determined. The method, however, is slow, as the air must be passed through very slowly to ensure complete absorption of the aqueous vapour, and also a considerable volume of air must be treated before any appreciable weight of moisture is absorbed. Further, it gives only the mean quantity of moisture present in the air during the time of experiment, and not the real quantity present at any particular moment. Consequently in meteorology the general practice is to use hygrometers whereby the relative humidity can be determined.

THE HAIR HYGROMETER.—An approximate value of the relative humidity (R.H.) can be obtained at any instant by using the Hair Hygrometer or Hygroscope. This consists essentially of a long human hair from which the oil has been removed by soaking it in alcohol. When so treated, the hair changes length with changes in the moisture in the atmosphere, and these changes in length are found to be directly proportional to the changes in the amount of moisture present. One end of the hair is rigidly fixed, while the other passes over a pulley and is kept taut by means of a weight attached to it. To the centre of the pulley is fixed a pointer which moves over a scale graduated from 0 to 100, these two points being fixed by trial. The relative humidity can then be read off at any instant. It requires to be standardized frequently, and when carefully attended will give the values correct to within 5 per cent. It has the advantage of recording with equal precision when temperatures are above or below freez-

ing-point. This instrument can be modified so that a continuous record of the relative humidity may be obtained. In this case the hair is fastened at both ends and kept taut in the middle by means of a hook. The changes in the humidity are magnified by means of a system of levers controlling a pen. The rise and fall of the pen is recorded on a chart placed on a revolving drum, the drum revolving once in seven days. The instrument is shown in fig. 53 (Plate I, facing p. 100).

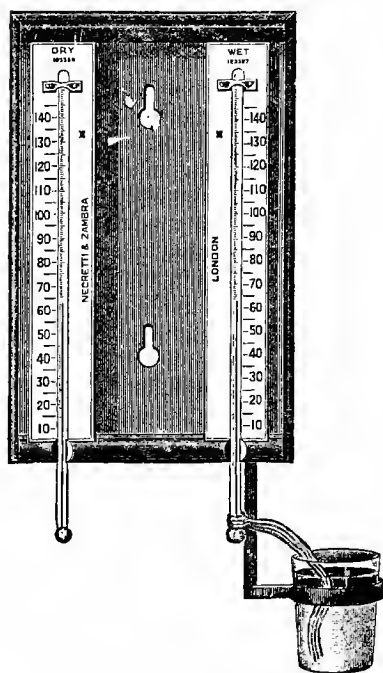

Fig. 54.—Wet- and Dry-bulb Hygrometer

fig. 54, consists of two ordinary thermometers, but round the bulb of one is tied a small piece of muslin, and from it extends a wick down into a vessel containing water. The evaporation from the surface of the muslin cools the bulb of the thermometer, so that the two thermometers indicate different readings. The less the moisture present in the air the greater the evaporation from the surface, and therefore the bigger the difference between the two readings. Pressure affects the readings only slightly, so that this effect is generally neglected. It is important that the psychrometer be properly exposed, and for this purpose it is placed in a ther-

DEW-POINT HYGROMETERS.—

Another type of hygrometer is the Dew-point Hygrometer, examples of which are the Dines, the Regnault, and the Daniell hygrometers. The principle in each of these is the same, a surface being cooled down until the temperature at which dew forms is determined. From this the pressure of the aqueous vapour present in the air is determined, and from the temperature of the air the maximum vapour pressure can be got, and hence the ratio of these two pressures gives the relative humidity. A description of these instruments is to be found in any textbook on physics.

THE WET- AND DRY-BULB HYGROMETER, OR PSYCHROMETER.

—This instrument, as shown in

nometer screen. Proper ventilation may also be secured by whirling the two thermometers, as is done in the case of the sling thermometer, or by means of the ventilation thermometer or Assmann psychrometer.

The last probably affords the best means of obtaining the correct difference between the dry- and wet-bulb temperatures.

For temperatures below 273° A. the wet bulb requires very careful attention. A thin layer of ice should be allowed to form on the bulb just before readings are taken, and, when the temperature of the wet bulb has become steady, the two thermometers should be read. If too thick a layer of ice be formed, the reading of the wet bulb will be too high. The instrument indicates neither absolute humidity, nor relative humidity, nor dew-point, but all three may be determined indirectly from its readings.

Glaisher's Relation.—Glaisher's hygrometric tables, which are in general use in the British Isles, are based on the determination of the dew-point from readings of the wet- and dry-bulb thermometers by the formula:

$$t - d = A (t - t'),$$

where t is the temperature of the dry bulb, t' the temperature of the wet, and d the temperature of the dew-point, the values being expressed in degrees Fahrenheit. The factor A was determined by many thousands of simultaneous observations of the dry and wet bulbs, and of a Daniell hygrometer. The values of A (Glaisher's factor) for different temperatures are given in Table XII.

Other Relations.—Another relation between the temperatures of the dry- and wet-bulb thermometers, and the vapour pressures at the temperatures of the wet bulb and of the dew-point, is obtained thus. If p be the pressure of aqueous vapour in the air at the time, p' the maximum pressure of aqueous vapour corresponding to θ' the temperature of the wet bulb, and h the barometric height, then the rate of evaporation will be proportional to $\frac{p' - p}{h}$.

But the rate of evaporation is also proportional to $\theta - \theta'$, where θ is the temperature of the dry bulb, θ and θ' being expressed in degrees absolute.

$$\therefore \frac{p' - p}{h} = A (\theta - \theta'),$$

where A is a constant depending on the ventilation to which the thermometers are exposed. Three cases are distinguished: (1) indoor

TABLE XII

GLAISHER'S FACTORS

Dry bulb. ° F.	Factor.	Dry bulb. ° F.	Factor.	Dry bulb. ° F.	Factor.
10	8.78	43	2.20	65	1.82
12	8.78	44	2.18	66	1.81
14	8.76	45	2.16	67	1.80
16	8.70	46	2.14	68	1.79
18	8.50	47	2.12	69	1.78
20	8.14	48	2.10	70	1.77
22	7.60	49	2.08	72	1.75
24	6.92	50	2.06	74	1.73
26	6.08	51	2.04	76	1.71
28	5.12	52	2.02	78	1.69
30	4.15	53	2.00	80	1.68
32	3.32	54	1.98	82	1.67
33	3.01	55	1.96	84	1.66
34	2.77	56	1.94	86	1.65
35	2.60	57	1.92	88	1.64
36	2.50	58	1.90	90	1.63
37	2.42	59	1.89	92	1.62
38	2.36	60	1.88	94	1.60
39	2.32	61	1.87	96	1.59
40	2.29	62	1.86	98	1.58
41	2.26	63	1.85	100	1.57
42	2.23	64	1.83		

readings without a fan or outdoor readings on occasions of a calm; (2) screen readings on occasions of light winds; (3) screen readings in moderate or strong winds or readings obtained with an Assmann psychrometer or sling psychrometer. Values corresponding to these three cases are 0.001200, 0.000800, and 0.000656. When the temperature is below freezing-point *and* the wet bulb covered with ice, the values used are slightly less, being 0.001060, 0.000706, and 0.000579 respectively. On this formula, known as Regnault's formula, and generally written in the form $e'' = e' - A. (t - t') B.$, are based the hygrometric tables used in other countries. B , e' , and e'' are measured in millimetres, and t and t' in degrees centigrade.

Diurnal Variation of Absolute Humidity.—This quantity is a mere number, and therefore the normal values can be found in exactly the same way as those for certain other meteorological elements, e.g. pressure. The normal hourly values, when computed for any particular month from data extending over a period of

years, show for a winter month a curve with one maximum and one minimum, following very closely the temperature curve. Thus, the minimum is found to occur about sunrise and the maximum in the afternoon between 14 h. and 15 h. In the summer-time the curve for an inland station shows two maxima and two minima. The first minimum, and the more important of the two, occurs about sunrise, while the second is found between 16 h. and 17 h. in the afternoon. The two maxima occur between 8 h. and 9 h. in the morning and between 20 h. and 21 h. in the evening. Over the sea and also at coast stations this double oscillation is not found. The amplitude of the variation is about double in summer what it is in winter.

Cause of the Diurnal Variation.—As the sun rises the rate of evaporation increases, and so the amount of water vapour in the air increases. This increase continues as long as the temperature increases, but after the period of maximum temperature is past, the rate of evaporation decreases but does not entirely cease. The water vapour in the lower layers, however, continues to diffuse more quickly to the upper layers than a fresh supply can evaporate from the earth's surface, so that the absolute amount in the lower layers decreases. At night evaporation often ceases altogether, and the absolute humidity is rendered still less by dew being deposited from the atmosphere.

The second minimum which occurs at inland stations in the summer-time in mean latitudes, and all the year round in tropical regions, is due to convection. By reason of the rapid convection in the middle of the day, the ascending air currents carry away the moisture from the lower layers more quickly than the rate of evaporation can supply moisture to the dry air coming in to replace the ascending moist air. Therefore, a decrease occurs in the absolute humidity, giving rise to a second minimum in the late afternoon. When convection becomes less active or ceases, then the absolute humidity begins to increase again, so that a second maximum takes place in the early evening. The supply of moisture from the ocean at island or coastal stations is always such as to prevent the second afternoon minimum.

Annual Variation.—The annual variation in absolute humidity can be found by plotting the mean monthly values. The minimum in general occurs in the winter season and the maximum in the late summer. This is due to the increase of evaporation during the

summer, and to the greater activity of plant and animal life at that season.

Variation with Latitude.—The variation in absolute humidity over the surface of the earth follows closely the variation in latitude. Over the Equator the amount is largest, and it decreases towards the poles. This is principally on account of the general decrease in temperature. Other factors, however, such as distance from the ocean and lack of vegetation, have a considerable influence, an example of which is afforded by the Sahara. In dry, desert regions such as these both the diurnal and annual variations in absolute humidity become very small.

Variation with Altitude.—The different layers of the atmosphere are often moving with different velocities and in different directions, and so there is apparently no regular variation of absolute humidity with height, but an irregular variation from one layer to the next. Yet when observations taken throughout a long period are examined, a regular diminution of vapour tension with height is found to exist. The law of decrease, according to Hann, is analogous to that of the decrease of pressure, or the tension of aqueous vapour decreases in geometrical progression as the height increases in arithmetical progression. The decrease, however, is much more rapid as the value of the tension for aqueous vapour is reduced to $\frac{1}{10}$ its value at a height of 1520 m., while that for the atmosphere is reduced to $\frac{1}{10}$ at 18,400 m.

Diurnal Variation in Relative Humidity.—The diurnal variation in relative humidity is approximately the inverse of that of the temperature. The maximum occurs near the time of sunrise and the minimum between 14 h. and 15 h. After sunrise the temperature of the air increases, and though the absolute amount of water vapour increases thereby, yet the capacity of the air for water vapour increases much more rapidly, so that the air becomes *relatively* drier. When temperature begins to fall in the afternoon, the capacity of the air for water vapour decreases, and even though the absolute amount of water vapour in the air decreases after the manner indicated above, yet the air becomes *relatively* damper. Saturation point is often reached in the early hours of the morning, especially if the night be calm and clear. Thereafter the curve given by a self-recording hygrograph continues nearly flat. The variation in the relative humidity at Aberdeen from 1st to 8th September, 1919, is shown in fig. 55.

The diurnal variations for Aberdeen and Kew have been computed from the hourly mean values, and are represented by fig. 56. The curves are for the months of January and July, and all show the features mentioned above, viz. a maximum near the time of sunrise and a minimum about 14 h. At Kew the minimum in summer is about 15 h. The range in summer is much greater than in winter, and less on the coast than inland, in both these respects closely following the temperature curves. These differences between the stations can be explained through the proximity of the Aberdeen station to the sea.

The reason for the connection between the temperature and relative humidity curves is at once apparent when we consider the expression for the relative humidity, viz. $e = 100f/F$. Now f varies but little during the day, so that $100f$ is approximately constant, whereas F varies directly with the temperature, so that the relative humidity varies almost inversely as the temperature.

Annual Variation.—The annual variation in relative humidity depends largely on

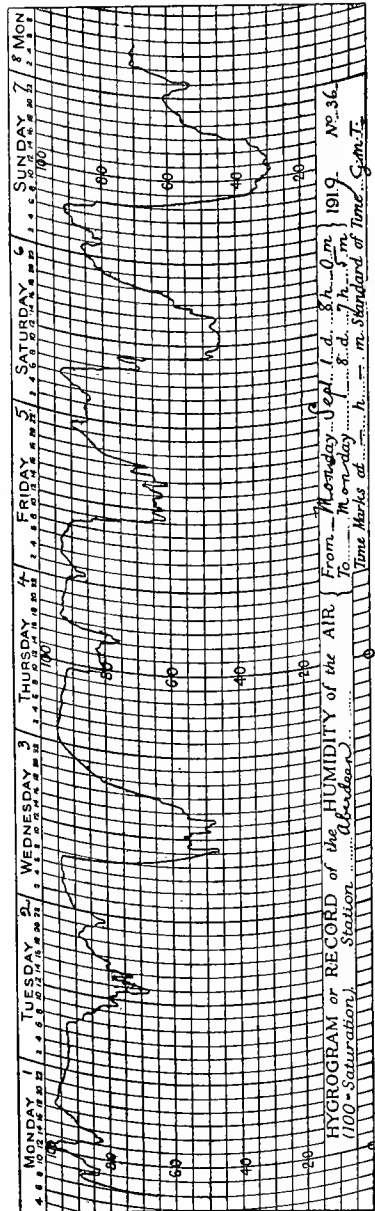

Fig. 55.—Hydrographic Record for One Week, showing Great Variation in the Humidity of the Several Days

the locality. The curves for Aberdeen and Kew in fig. 57 show a minimum in June for both cases, and a maximum in November, though the values for the months of October, November, and December are practically identical in the case of Aberdeen. In some countries where the winter is dry and fine, and where the rainy season occurs in summer, the maximum occurs in summer and the minimum in winter, thus resembling the absolute humidity. Such is the case at Pekin and in some other parts of Asia.

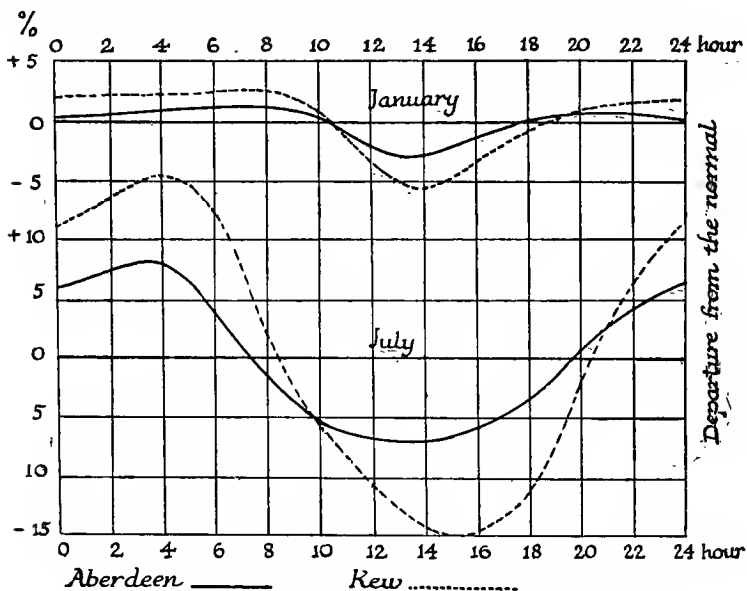

Fig. 56.—Diurnal Variation in Relative Humidity for the period 1886-1910

Mean values, January (Aberdeen), 80.3 per cent; (Kew) 84.7 per cent.

July (Aberdeen), 78.3 per cent; (Kew) 72.9 per cent.

The effect of the sea is again seen in the curves of annual variation, for though the mean value for the two stations is almost identical, yet the amplitude of the variation for Kew is nearly $3\frac{1}{2}$ times that for Aberdeen.

Variation with Latitude.—Unlike the absolute humidity, the relative humidity does not decrease from a maximum at the Equator to a minimum at the poles. Near the Equator it shows a relative maximum of about 80 per cent. Thereafter it decreases to about 70 per cent in the regions of the high-pressure belts in lat. 30° to 35° , and afterwards increases again to 80 or 90 per cent in the polar

regions. Local conditions, however, influence it considerably. Off Newfoundland, for example, where the warm air coming from above the Gulf Stream passes over the cold Labrador current, fogs are frequent, and the relative humidity often remains for long periods in the neighbourhood of 100 per cent.

Variation with Altitude.—The variation of the relative humidity with height is much less exact than that of the absolute humidity, and no definite law can be given in this case. In or near a cloud

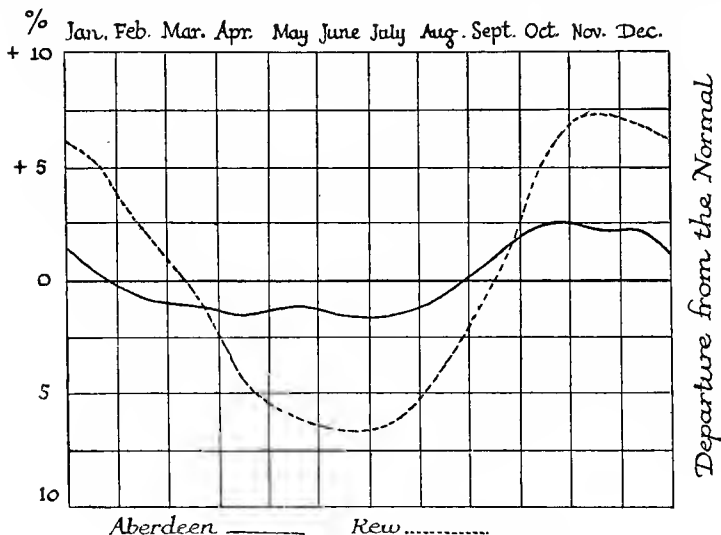

Fig. 57.—Annual Variation in Relative Humidity
 Mean values (Aberdeen) 79.8 per cent; (Kew) 79.3 per cent.

the value may be 100 per cent, and yet above or below the cloud layer, at a comparatively short distance from the first position, the relative humidity may be entirely different.

B.—CONDENSATION

We have seen that air containing water vapour when cooled down reached the point of saturation, and any cooling beyond that resulted in dew being deposited or cloud formed, i.e. a certain amount of the water vapour was condensed. Condensation, therefore, is the reverse of evaporation, and consists in the change of

a substance, in this particular case water vapour, from the gaseous condition to the liquid or solid state.

Methods of Causing Condensation.—Condensation may be brought about in two ways, either by compression or by cooling. The first method can only be performed in the laboratory, and cannot take place in the free atmosphere. We shall therefore consider the case of condensation by cooling only. This may take place in three ways: (1) by direct cooling, (2) by expansion, (3) by mixing. By direct cooling fogs are produced, either radiation fogs or fogs arising from the passage of warm, moist air over a cold surface. Large, billowy clouds, or roll clouds, show the effect of expansion, and the mixing of two air currents of different temperatures, and containing different amounts of water vapour, is shown in the production of cloud of the stratus type, or in a straight line of cloud stretching at times right across the sky. This method, however, is not very fruitful in the production of clouds.

Cooling by Expansion.—In Chapter IV we saw that temperature decreased with height at a rate of 1° A. for every 101 m., i.e. the adiabatic rate for dry air is 1° A. per 101 m. But if the air contains moisture the adiabatic rate varies according to the amount of moisture present, an average being 1° A. per 103 m. This holds so long as no condensation takes place, but immediately condensation sets in the law is quite different, as with the liberation of heat through condensation the rate of decrease of temperature with height, or the lapse rate, as it is generally called, is less, and is variable, depending entirely on the pressure and temperature at each instant. In the mean it is about 1° A. for every 180 m., as long as the temperature is above 273° A. Below this temperature water freezes, and the further liberation of heat due to freezing reduces the lapse rate still more. Thus the cooling of air due to expansion arising from reduced external pressure is considerably reduced through condensation.

Hertz Diagram.—In 1884 Hertz introduced a graphic method of following the changes taking place in moist air. He considered four stages in the process: first, the stage where the air is unsaturated and no liquid water is present; second, the air saturated, and water present also in the liquid form; third, the air saturated, and also water and ice present; and fourth, the air saturated, but only vapour and ice present; and these four stages he called the dry, the rain, the hail, and the snow stages. In the diagram

absolute temperatures were laid off as ordinates and pressures as abscissæ; but instead of the values themselves being used, which would result in a series of curves, the logarithms of the values are marked. The number of grammes of moisture present in each kilogram of atmospheric air under the various conditions is indicated by one series of lines. The adiabatics in the three stages—

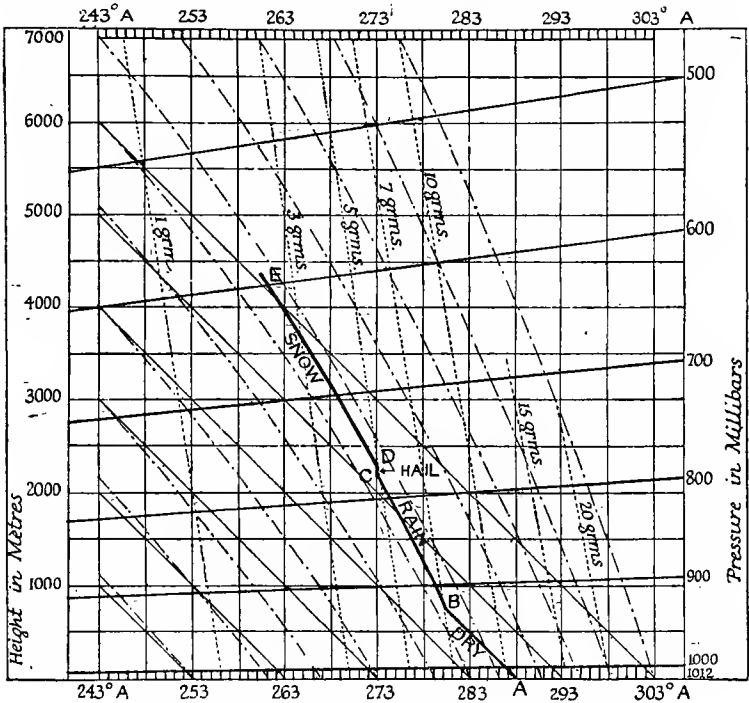

Fig. 58.—Adiabatic Diagram (modified from Neuhoff-Hertz)

dry, rain, and snow—are represented by three sets of parallel lines crossing the diagram; while in the hail stage the courses coincide with the 273° A. isotherm. By means of this diagram it is possible for one, on knowing the initial conditions of pressure, temperature, and humidity, to follow the changes that take place when a mass of air ascends or moves to a place of lower pressure, and to see where it enters the various stages.

The Modification of Hertz Diagram by Neuhoff.—In 1900 Neuhoff modified the Hertz diagram. In this new dia-

gram absolute temperatures are plotted as abscissæ, and heights as ordinates, while pressure is represented by slanting cross lines, and is read by scales on either side of the diagram. The dotted lines in the diagram, fig. 58, represent the constant quantity of moisture needed for saturation. The straight lines running parallel to the diagonals of the small squares represent the adiabatics in the dry stage, while those in the condensation stage are represented by the broken, slightly curved lines.

Neuhoff starts with the assumption that the amount of moisture will remain constant throughout the ascent, or that $(1 + x)$ kilograms of moist air will remain constant where x is the quantity of vapour mixed with 1 kg. of dry air. This quantity x is called the mixing ratio and for high altitudes is very small, amounting to 2 or 3 grm. only per kilogram of dry air.

Use of Adiabatic Diagram.—The following will serve as an example of the use of the diagram. Let a mass of air have an initial pressure of 1012 mb., initial temperature 288° A., and relative humidity 70 per cent. The amount of water vapour necessary for saturation would be about 10.2 grm., so that the amount actually present will be 7.1 grm. The point of saturation is then found by following the dry adiabatic until it intersects the saturation line representing 7.1 grm. at the point B. This is the dry stage. At the point B the pressure is 920 mb., the temperature 280° A., the vapour pressure 10 mb., and the height 800 m. The air is saturated, so that above this condensation begins and will continue until the temperature falls to 273° A. During this stage, which is the rain stage, the moisture condenses in the form of water, and when the point C is reached this stage ends. At this point the pressure is 780 mb., the temperature 273° A., the vapour pressure 6 mb., and the height about 2230 m. The quantity of vapour is 5 grm., so that 2.1 grm. have been formed into rain. In the third or hail stage the 2.1 grm. are frozen without reduction of temperature. This means that the whole mass is raised about 70 m. farther, so that at the point D the conditions are: pressure 760 mb., temperature 273° A., vapour pressure 6 mb., the amount of ice about 2.1 grm., and the height 2300 m. Further ascent and cooling will result in the formation of snow, i.e. we are in the snow stage. At a height of 4250 m. the pressure becomes 600 mb., temperature 261° A., the weight of the vapour 2.75 grm., so that the amount of snow = $(5 - 2.75) = 2.25$ grm.

One fault about the diagram is that it assumes all the moisture to be carried through all the stages, whereas the rain and snow generally separate out from the ascending air. This method of cooling by expansion is the method whereby large rainfalls are produced in comparatively short periods. The diagram also assumes that freezing takes place immediately under 273° A. But water-droplets often exist at temperature considerably below 273° A., and therefore the diagram does not represent what occurs in every case.

Condensation by Direct Cooling.—This takes place in two ways, either by warm air coming in contact with a cold surface, or by radiation. The warm air coming from lower to higher latitudes comes in contact with colder earth surfaces, so that it becomes cooled and condensation takes place. There is seen a similar effect off the coasts of Newfoundland, where the warm air coming either from the American continent or from off the Gulf Stream is cooled on passing over the cold waters of the Labrador current. These form examples of the first method of condensation by direct cooling. The second method, that by radiation, often results in the production of fogs over plains and in valleys on calm, clear nights. The cooling is confined to a shallow layer sometimes less than a foot thick.

Through the method of direct cooling a considerable quantity of rain can be produced, but the process is very slow.

Condensation by Mixing.—If two equal masses, temperatures 280° A. and 290° A., saturated with water vapour, be mixed, then the resulting temperature will be 285° A. approximately. The vapour pressures corresponding to 280° A. and 290° A. are 9.96 mb. and 19.2 mb. respectively, and that for 285° A. is 13.91 mb. Now

$$\frac{9.96 + 19.2}{2} = 14.58,$$

which is greater than 13.91 by 0.67, so that the vapour pressure would be greater than that for saturation at 285° A., and thus part of the vapour condenses out. The quantity of water actually condensed out is slightly less than the figures show, as the temperature of the mixture is a little higher than that indicated owing to small quantities of heat liberated on condensation taking place. The amount of rain produced by this method is very small.

CLOUDS

When water vapour condenses in the atmosphere by any of the methods indicated above, it remains at first suspended as small droplets, for if it commences to fall, the resistance offered by the air to the drop is sufficient to prevent its falling. Only when a number of droplets have coalesced to form a drop of sufficient weight to overcome this resistance does the moisture fall as rain. The resistance of the air for a given velocity is proportional to the surface of the drop, i.e. to the square of the radius, whereas the weight is proportional to the cube of the radius, and so a point is reached where the weight is greater than the resistance of the air for a given velocity and the drop falls to the ground.

Droplets Solid, not Hollow.—The nuclei of these droplets are dust particles or ions, and the drops are solid, not hollow. For if they were hollow the pressure inside, on account of their size, would be very much greater than that outside by reason of surface tension, and the drops would burst asunder.

When near the surface of the ground these drops go to form fogs, and when raised above the ground in the free atmosphere they form clouds. In the highest types of clouds, the particles consist not of water droplets but of ice crystals.

The particles within a cloud are continually in motion, and evaporation and condensation are continually going on side by side, so that though the cloud itself may appear practically unchanged in shape for some time, yet its constituent parts are changing unceasingly. This unceasing change is often quite apparent in a cloud that is moving quickly, but close attention will also show that it is at work in a cloud which is practically stationary.

Classification of Clouds.—The clouds formed one of the first meteorological phenomena to attract the attention of man, and frequent reference to them is to be found in the earliest writings. No classification of them was attempted, however, until the beginning of the nineteenth century, the first classification being made by Lamarck, a French naturalist, in 1801.

HOWARD'S CLASSIFICATION.—Two years later Luke Howard¹ set forth a classification which forms the basis of the present classification. He classified the clouds according to four fundamental types,

¹ *Phil. Mag.*, 1803.

and intermediate forms were denoted by combinations of these four fundamentals. These four types were: (1) nimbus, for rain clouds; (2) stratus, for widespread flat sheets; (3) cumulus, for clouds of a piled-up, rounded shape; (4) cirrus, for the high, feathery type. This classification found general acceptance, and his essay was reprinted in 1832, translated into various languages, and the classification adopted by the various official meteorological services.

CLAYTON'S CLASSIFICATION.—Several other classifications have been suggested since Howard's time, but the majority are really Howard's classification with slight modifications, and very few entirely new systems have been proposed. One of the latter was that proposed by Clayton¹ in 1889, and based on the origin of the cloud. He suggested five types:

- | | |
|--|--------------------------------------|
| 1. Clouds due to local vertical ascending currents, | Cumulus clouds. |
| 2. Clouds due to slow oblique ascending currents, | Stratiform clouds. |
| 3. Clouds due to chilling of lower air by radiation, | Fogs. |
| 4. Clouds due to evaporation of the thinner parts of clouds
already formed, probably caused by descent, - | } Alto-cumulus and
cirro-cumulus. |
| 5. Clouds due to differences in the direction and velocity
of air currents at different levels, | |

CLEMENT LEY'S CLASSIFICATION.—Clement Ley, in 1894, gave in his book *Cloudland* the following classification: (1) radiation clouds, fog types; (2) interfret clouds, horizontal current clouds; (3) inversion clouds, cumulus types; (4) inclination clouds, cirrus types.

THE INTERNATIONAL CLASSIFICATION.—In order to arrive at uniformity, the International Meteorological Conference agreed in 1890 to establish an international cloud classification, and ten types of clouds were agreed upon. In 1894 the committee appointed to prepare an atlas representing the forms, with the nomenclature proposed by Hildebrandsson and Abercromby, defined the ten types of cloud proposed, and in 1896 there was published the international cloud atlas by Hildebrandsson, Riggenbach, and de Bort. The definitions given below are those from the international atlas of clouds which was approved by the International Conference of Directors of Meteorological Institutes and Observatories at Innsbruck in 1905, and published by Gauthier Villars in 1910.

¹ *Annals, Harvard Obs.*, Vol. XXX, Part IV, 1896.

INTERNATIONAL DEFINITIONS AND DESCRIPTIONS OF
CLOUD FORMS

1. CIRRUS (Ci.); Plate II (a).—“Detached clouds of delicate appearance, fibrous (thread-like) structure, and feather-like form, generally white in colour.” Cirrus clouds take the most varied shapes, such as isolated tufts of hair, i.e. thin filaments on a blue sky, branched filaments in feathery form, straight or curved filaments ending in tufts (called *Cirrus uncinus*), and others. Occasionally cirrus clouds are arranged in bands, which traverse part of the sky as arcs of great circles, and, as an effect of perspective, appear to converge to a point on the horizon, and at the opposite point also if they are sufficiently extended. Cirro-stratus and cirro-cumulus also are sometimes similarly arranged in long bands.

2. CIRRO-STRATUS (Ci.-St.), Plate II (b).—“A thin sheet of whitish cloud, sometimes covering the sky completely and merely giving it a milky appearance; it is then called cirro-nebula or cirrus haze; at other times presenting more or less distinctly a fibrous structure like a tangled web.” This sheet often produces halos around the sun or moon.

3. CIRRO-CUMULUS (Ci.-Cu.) (Mackerel Sky), Plate III (a).—“Small rounded masses or white flakes without shadows, or showing very slight shadow; arranged in groups and often in lines.” French, *Moutons*; German, *Schäfchen-wolken*.

4. ALTO-STRATUS (A.-St.), Plate III (b).—“A dense sheet of a grey or a bluish colour, sometimes forming a compact mass of dull grey colour and fibrous structure.” At other times the sheet is thin, like the denser forms of cirro-stratus, and through it the sun and the moon may be seen dimly gleaming as through ground glass. This form exhibits all stages of transition between alto-stratus and cirro-stratus, but, according to its measurements, its normal altitude is about one-half of that of cirro-stratus.

5. ALTO-CUMULUS (A.-Cu.), Plate IV (a).—“Larger rounded masses, white or greyish, partially shaded, arranged in groups or lines, and often so crowded together in the middle region that the cloudlets join.” The separate masses are generally larger and more compact (resembling strato-cumulus) in the middle region of the group, but the denseness of the layer varies, and sometimes is so attenuated that the individual masses assume the appearance of sheets or thin flakes of considerable extent with hardly any



a. CIRRUS, true type, showing thread structure



b. CIRRO-STRATUS, in dense sheets

From photographs by G. A. Clarke, F.R.P.S. Copyright.



a. CIRRO-CUMULUS: globular and wavy forms



b. ALTO-STRATUS. uniform sheet with degraded cumulus below
From photographs by G. A. Clarke, F.R.P.S. Copyright.

shading. At the margin of the group they form smaller cloudlets resembling those of cirro-cumulus. The cloudlets often group themselves in parallel lines, arranged in one or more directions.

6. STRATO-CUMULUS (St.-Cu.), Plate IV (b).—“Large lumpy masses or rolls of dark-grey cloud, frequently covering the whole sky, especially in winter.” Generally strato-cumulus presents the appearance of a grey layer broken up into irregular masses, and having on the margin smaller masses grouped in flocks like alto-cumulus. Sometimes this cloud form has the characteristic appearance of great rolls of cloud arranged in parallel lines close together (*Roll-cumulus* in England, *Wulst-cumulus* in Germany). The rolls themselves are dense and dark, but in the intervening spaces the cloud is much lighter, and blue sky may sometimes be seen through them. Strato-cumulus may be distinguished from nimbus by its lumpy or rolling appearance and by the fact that it does not generally tend to bring rain.

7. NIMBUS (Nb.), Plate V (a).—“A dense layer of dark, shapeless cloud with ragged edges, from which steady rain or snow usually falls. If there are openings in the cloud an upper layer of cirro-stratus or alto-stratus may almost invariably be seen through them.” If a layer of nimbus separates in strong wind into ragged cloud, or if small, detached clouds are seen drifting underneath a large nimbus (the “*Scud*” of sailors), either may be specified as *Fracto-nimbus* (Fr.-Nb.).

8. CUMULUS (Cu.) (Wool-pack or cauliflower cloud), Plate V (b).—“Thick cloud, of which the upper surface is dome-shaped and exhibits protuberances, while the base is generally horizontal.” These clouds appear to be formed by ascensional movement of air in the day-time, which is almost always observable. When the cloud and the sun are on opposite sides of the observer, the surfaces facing the observer are more brilliant than the margins or protuberances. When, on the contrary, it is on the same side of the observer as the sun, it appears dark with bright edges. When the light falls sideways, as is usually the case, cumulus clouds show deep shadows.

True cumulus has well-defined upper and lower margins; but one may sometimes see ragged clouds—like cumulus torn by strong wind—of which the detached portions are continually changing; to this form of cloud the name *Fracto-cumulus* may be given.

9. CUMULO-NIMBUS (Cu.-Nb.) (the Thunder Cloud, the Shower Cloud), Plate VI (a) and (b).—“Great masses of cloud rising in the

form of mountains or towers or anvils, generally having a veil or screen of fibrous texture (false cirrus) at the top and at its base a cloud mass similar to nimbus." From the base local showers of rain or of snow, occasionally of hail or of soft hail, usually fall. Sometimes the upper margins have the compact shape of cumulus, or form massive heaps round which floats delicate false cirrus. At other times the margins themselves are fringed with filaments similar to cirrus clouds. This form is particularly common with spring showers. The front of a thunderstorm of wide extent is frequently in the form of a large low arch above a region of uniformly lighter sky. False cirrus detached from the parent *Cumulo-nimbus* cloud is shown in Plate VII (a).

10. STRATUS (St.).—"A uniform layer of cloud like fog, but not lying on the ground." The cloud layer of stratus is always very low. If it is divided into ragged masses in a wind or by mountain tops, it may be called *Fracto-stratus*. The complete absence of detail of structure differentiates stratus from other aggregated forms of cloud.

The following remarks are added in the international atlas as instructions to observers:—

(a) In the day-time in summer all the lower clouds assume, as a rule, special forms more or less resembling cumulus. In such cases the observer may enter in his notes *Stratus-* or *Nimbus-cumuliformis*.

(b) Sometimes a cloud will show a mammillated surface, and the appearance should be noted under the name *mammato-cumulus*.

(c) The form taken by certain clouds, particularly on days of sirocco, mistral, föhn, &c., which show an ovoid form with clean outlines and sometimes irisation, will be indicated by the name *lenticular*; for example, *cumulus lenticularis*, *stratus lenticularis* (Cu.-lent., St.-lent.).

(d) Notice should always be taken when the clouds seem motionless or if they move with very great velocity; also especially when different layers show marked differences in velocity.

In addition to the definitions of the ten types given above, the definition of a lenticular form of cloud is added.

11. LENTICULAR CLOUD BANKS, Plate VII (b).—"Banks of cloud of an almond or airship shape, with sharp general outlines, but showing, on close examination, fretted edges, formed of an ordered



a. ALTO-CUMULUS, in parallel bands



b. STRATO-CUMULUS, heavy masses

From photographs by G. A. Clarke, F.R.P.S. Copyright.



α. NIMBUS: a passing shower with a rainbow



β. CUMULUS: detached typical form

From photographs by G. A. Clarke, F.R.P.S. Copyright.

structure of cloudlets similar to alto-cumulus or cirro-cumulus, which is also seen in the bank itself when the illumination is favourable." Sometimes the body of the cloud is dense, and the almond shape is complete, fore and aft, but sometimes the bank thins away from the forward edge to clear sky within, so that the bank presents the appearance of a horse-shoe seen in perspective from below at a great distance. The bank appears nearly or quite stationary, while the cloudlets move rapidly into it at one side and away from it at the other.

Cloud Observation: their Height.—In order to measure the height of a cloud, simultaneous observations are made on the same point in the cloud at two stations a known distance apart. From the two angles so found, and the length of the base, the triangle can be solved trigonometrically. Observation shows that the clouds are higher in summer than in winter, and that on the average, for clouds of the same type, the height tends to decrease with increase in latitude. The following table, from measurements made during 1896-7,

TABLE XIII

Type.	Sweden (Upsala).	Germany (Potsdam).	France (Trappes).
	m.	m.	m.
Cirrus	8180	9050	8940
Cirro-stratus	6360	8090	7850
Cirro-cumulus	6460	5890	5830
Alto-cumulus	3430	3630	3680
Alto-stratus	2770	3290	3790
Strato-cumulus	1770	2160	1820
Nimbus	1200	1790	1080
Cumu- } Top	2000	2100	2160
lus } Base	1450	1640	1450
Fracto-cumulus	1830	1710	1400
Cumulo- } Top	3970	3990	5490
Nimbus } Base	—	2060	2530
Stratus	—	670	940

gives the mean heights for the various types. The range in the values is often considerable; thus, alto-stratus ranges from 3000 m. to 7000 m., and cirrus is found as low as 5400 m. and as high as 15,000 m.

Their Direction and Velocity.—The direction and the velocity of the clouds can also be measured in the same way as their height.

For if a second pair of simultaneous observations be taken at a known interval of time after the first, then the distance passed over in the time and also the direction of motion of the cloud is definitely established. The velocity and the direction of the current in which the cloud is moving may also be determined by means of a pilot balloon. As the cloud particles move with the same velocity as the air current, this method will also give the cloud direction and velocity.

For measurements in the manner described above, two observing stations are necessary, and also two observers. A much simpler method of determining the direction is by means of a nephoscope, of which two kinds are used, (1) reflecting nephoscope, (2) direct vision nephoscope.

The Fineman Nephoscope.—This affords an example of the first type. It consists of a circular plate of black glass mounted on a tripod, which permits of accurate levelling. A vertical pointer, on which a millimetre scale is marked, is attached to the edge of the plate by a brass ring, and this with the plate can be rotated about a vertical axis. The pointer can be raised or lowered as desired. On the disc are three concentric circles whose radii are in arithmetical progression, and four radii drawn at right angles to each other. The brass ring on which the plate is fixed is divided into degrees; and this ring rests on another fixed ring on which the cardinal points of the compass are marked. To make an observation the observer places the instrument with the north-south diameter of the plate in the proper meridian, and then adjusts the instrument until the tip of the pointer, the image of the cloud, and the centre of the disc are in one and the same straight line. He then moves his head so as to keep the tip of the pointer and the image of the cloud in the same straight line with his eye, and notes the radius along which the image appears to move. This gives the direction of the cloud drift.

The absolute velocity of the cloud cannot be determined by this instrument, but the velocity-height ratio can be determined. The plate is arranged so that the radius passing through the pointer is perpendicular to the direction of motion of the cloud, and the time that the image takes to travel from one circle to the next noted, the eye of the observer, the tip of the pointer, and the image of the cloud being kept in one straight line, while the observer keeps himself absolutely steady. If the distance between the circles be



a. CUMULO-NIMBUS: anvil-topped form associated with thunderstorms



b. CUMULO-NIMBUS: massive hail and shower clouds
From photographs by G. A. Clarke, F.R.P.S. Copyright.



a. FALSE CIRRUS, above small cumulo-nimbus cloud group



b. ALTO-CUMULUS, massed into lenticular banks
From photographs by G. A. Clarke, F.R.P.S. Copyright.

a and the height of the tip of the pointer above the surface be b , and the time taken by the image to travel be t seconds, then the value of the velocity-height ratio is a/bt . If now the cloud be assumed to be 1000 metres above the ground, the velocity in $m/s = 1000 \times \frac{a}{bt}$. Thus, assuming the average values for the cloud heights, the velocity for any cloud can be found approximately.

From the diagram, fig. 59, the velocity-height ratio can easily be calculated. For let AB represent the height of the pointer above

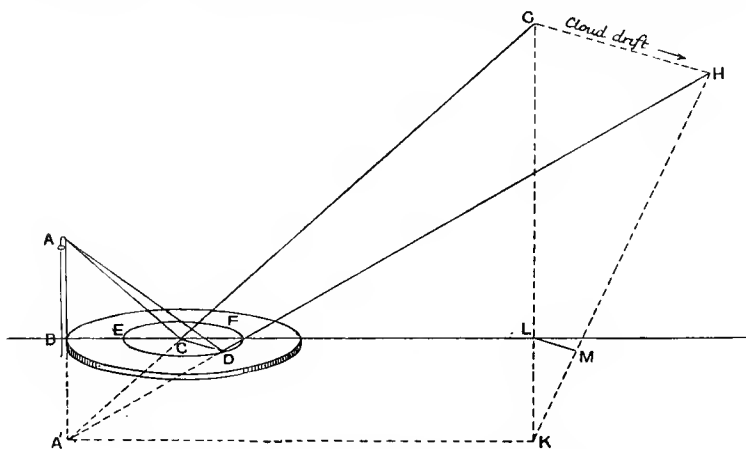

Fig. 59.—Illustrating the Theory of the Fineman Nephoscope

the plate. Then the image A' of A in the mirror is as far below the surface as A is above it, i.e. $AB = A'B$. C is the centre of the concentric circles on the plate, and CD is a radius of the circle DEF , this radius being parallel to the direction of the cloud GH . Let K be the point vertically below G , join KH , and let LM be the intercept on the horizontal plane through the plate made by the two lines GK and HK . Then CD and LM are both parallel to GH , and therefore

$$\frac{CD}{GH} = \frac{A'C}{A'G} = \frac{KL}{KG} = \frac{LM}{GH}$$

i.e. $CD = LM$.

Now the angle through which an observer at the point K follows the cloud is the angle GKH . To an observer at the point A , the ray from the first position of the cloud passes along the line GCA , and from the second position along HDA , so that the angular

motion is measured by the angle GA'H. Thus, the velocity-height ratio is given by

$$\frac{GH}{t \times GK} = \frac{LM}{t \times KL} = \frac{CD}{t \times A'B} = \frac{CD}{t \times AB} = \frac{a}{bt}$$

The Comb Nephoscope.—The Besson Comb Nephoscope serves as an example of the direct vision nephoscope. The principle is the same as in the reflection type, but instead of watching the image, the cloud itself is observed. The comb, which consists of a number of spikes placed at equal distances apart, is adjusted so that the cloud appears to travel along the line of the spikes. Thus, the direction is obtained. The velocity-height ratio is determined by noting the time taken to travel from one spike to the next. If a is the distance between the spikes, b the height of the tips of the spikes above the observer's eye, and t the time in seconds, then the velocity-height ratio = a/bt .

Formation of Clouds.—The various methods of condensation have been described, and we shall now consider briefly how the various types of cloud arise.

Cirrus clouds are explained as being formed by the difference in velocity of two upper air currents. In the layer in which the cloud finds itself the upper part will be moving with a greater velocity than the lower, and thus the top part of the cloud will move in advance of the lower, and the cloud will be drawn out into long thin fibrous streaks. The direction of these cirrus bands is generally from west to east, which is the general direction of the air currents at the cirrus level. Also as the top layers are moving more quickly than the lower, some reduction of pressure is likely to take place through the flowing away of some of the superincumbent air, whereby the whole atmosphere is rarefied as by the stroke of a pump. Then, in Shaw's opinion, condensation takes place in the damp layers or currents, producing thereby the characteristic fibrous structure.

Clouds caused by Wave Motion.—Cloud billows or undulations such as cirro-cumulus, alto-cumulus, and strato-cumulus, have a different origin from cirrus, and are formed by wave motion in the atmosphere. There are many examples in nature of the effect of wave motion. The ripples on sand are due to the passage of sea waves backwards and forwards. Helmholtz was the first to draw attention to the resemblance between ripples due to wave motion



a. STRATO-CUMULUS, upper surface, as seen from an aeroplane
From photograph by Capt. C. J. P. Cave, F.R.P.S.



b. CUMULO-NIMBUS, the summit of a thundercloud
From photograph by Capt. C. K. M. Douglas, R.A.F.

and the appearance of certain types of clouds. He suggested that the clouds also were due to wave motion caused at the junction of two air currents. If two air currents possess a different density, or different velocity, or both, then undulations arise at their junction. As this wave motion passes through the atmosphere, there is a continual rise and fall of the particles, and therefore expansion and condensation take place, followed by compression and evaporation. A series of clouds arranged in parallel lines should therefore be formed, and this is well marked at the strato-cumulus and alto-cumulus levels, where the clouds appear in long parallel rows. The effect is also apparent on stratus types at all levels, the stratus sheet being divided into lines or furrows, seen in ordinary stratus, alto-stratus, and in cirro-stratus. Very often two such trains of waves can be seen to meet and cross one another, the different systems being clearly marked by the clouds formed. This is very noticeable in the cirro-cumulus level.

Pilot balloon observations made early in the day often give an indication as to whether clouds due to this cause are likely to form later in the day; for if the pilot balloon record shows a marked change in the wind both in direction and velocity at a particular height, then very often clouds of this undulating type appear later in the day at that level.

The upper surfaces of clouds of this type present an undulating appearance like the waves of the sea. Plate VIII (*a*) shows the upper surface of an ordinary strato-cumulus layer.

Clouds of this type, however, form not only at the boundary of two different currents, but also within an air current, and Shaw has suggested¹ that these clouds are due to eddy motion propagated upwards from the surface of the earth. These clouds have a marked tendency to disappear after sunset, as one would expect on this theory, for after sunset the level reached by the turbulent motion becomes lower, and so condensation will no longer take place, the air within which the turbulent motion now takes place being no longer saturated.

Clouds caused by Vertically-ascending Currents.—When the surface of the earth becomes heated by the sun's radiation, evaporation and convection set in. As the mass of warm moist air is forced upwards the pressure on it becomes less, and it gradually expands and cools until at a certain point condensation begins.

¹*Manual of Meteorology*, Part IV, p. 49.

This sets free a certain amount of heat, and so convection goes on within the cloud itself, and the top of the cloud becomes dome-shaped. The under side of the cloud is flat, as it is on the plane where the ascending air becomes saturated and condensation sets in. The height of this under surface above the earth depends (1) on the original temperature of the air at the surface, (2) on the amount of moisture present in unit mass of air, and (3) on the rate of decrease of temperature with height, or the temperature lapse rate. If this lapse rate is small, then the convection currents will be feeble, and will not ascend far into the atmosphere, and the sky may remain cloudless. But, on the other hand, if the lapse rate is considerable, then the convection currents become very marked as temperature at the surface increases, and cumulus clouds develop rapidly, covering large portions of the sky. When convection becomes fairly active within the cloud, slight showers sometimes fall, but from a simple cumulus this is not common. Further development must take place, and convection within the cloud become very active so that the currents ascend to 4000 or 5000 m. before the real shower-cloud or cumulo-nimbus is formed. From the tops of those clouds stream out soft fibry cirrus-like clouds known as false cirrus, and these portions consist of ice crystals, as shown by the optical phenomena they exhibit. Sometimes the whole top spreads out like an anvil with this false cirrus streaming out in all directions, and from these clouds fall heavy rain or hail showers, and in them thunderstorms are developed. See Plate VI (b).

Both cumulus and cumulo-nimbus are day clouds, and generally disappear towards evening. The average heights of both base and top of these clouds are given in Table XIII. The average height of the base of cumulo-nimbus as given in the table appears, however, a little in excess of more recent measurements, which indicate a value near that for the base of the ordinary cumulus, or even slightly lower.

The cauliflower appearance of the upper surface of the cumulo-nimbus is well marked in Plate VIII (b).

Clouds formed by Obliquely-ascending Currents.—Stratus and nimbus clouds formed near the centres of low-pressure areas are explained as being caused by obliquely-ascending currents. When the air trajectories are drawn for a low-pressure centre, they show the air coming in towards the low centre from the south-west in the Northern Hemisphere. These currents are comparatively

warm and are moisture-laden, and, as they rise up over the colder currents coming in from the north-east, the air expands and cools, and clouds either of the stratus or nimbus type are formed. Eddy motion is also responsible for the formation of stratus clouds.

Stratus is often of the nature of a lifted fog, and its origin is the same as that of a fog caused by warm moist air passing over a cold surface. This type of stratus is often seen in the neighbourhood of Aberdeen when the wind is in the east, and the land warmer than the sea surface. When the fog reaches the coast-line the portion of the fog nearest the ground dissipates, and the fog passes over the city as a stratus cloud. In this case there is a decrease of temperature from the ground upwards to the cloud base, which does not take place in the case of fog (see later), and afterwards in all probability an inversion near the top of the cloud layer. The fall of temperature from the ground upwards is shown by the difference in temperature indicated by the thermometers in the screen 4 ft. above the ground and those in the screen 40 ft. above the ground, the difference being often as much as 3° A. This type of stratus is often very thin, the sun being visible through it.

Clouds of the stratus type often form in still air in cold anti-cyclonic weather in winter time, and this type, W. H. Dines has suggested, is due to radiation.

Cloud Amount.—A few observations suffice to show that there is a direct relation between the average amount of cloud and the amount of bright sunshine. If then a close examination of the sunshine records of a station be made, one is able to form some idea of the average amount of cloud probable on an average day during daylight in the neighbourhood of that station in any particular month of the year. Unfortunately little is known about night cloudiness, as few moonlight or starlight records are available.

The Sunshine Recorder.—Continuous records of bright sunshine are obtained by the sunshine recorder. Various types of recorder have been employed, some thermometric, others photographic. The type in general use in the British Isles is the Campbell-Stokes Sunshine Recorder, see fig. 60. It consists of a spherical glass lens, 4 in. focal length, which focuses the sun's rays on a strip of prepared paper held in a groove. There are three lengths of paper employed and a groove for each length, one for the summer period, 13th April to 31st August, one for the winter, 13th October to 28th February, and one for the two equinoctial

periods, 1st March to 12th April, and 1st September to 12th October. The instrument has to be adjusted for latitude, and the method of doing so is shown in fig. 60 (a).

A record of moonlight may also be obtained by means of this instrument by using a strip of not oversensitive paper in place of the sun-card. The paper so employed must be well protected from the weather, and the altitude of the moon must be known, so that the paper may be placed in the proper groove. In this way a satisfactory record of moonlight may be obtained, giving thereby an

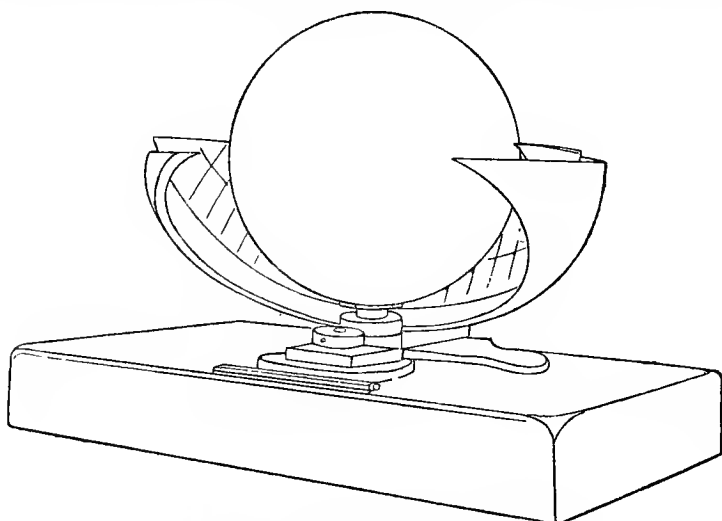

Fig. 60.—The Campbell-Stokes Sunshine Recorder

indication of night cloudiness. This method of observing night cloudiness is only possible when there is moonlight, and so a method depending on a less variable quantity than moonlight is desirable. For this purpose Pickering devised in 1885 an instrument for obtaining a photographic record of the pole-star, and this instrument was subsequently modified in 1904 by Fergusson. The instrument is so devised that it can run for a fortnight without the sensitive paper being changed. When the paper is developed a series of arcs of circles is obtained, the missing portions indicating where the pole-star became obscured by cloud. The night cloudiness in the pole-star region of the sky is thus indicated, but conditions in the other parts of the sky are not shown, though they may be inferred from this record and from a knowledge of the general meteorological

situation at the time. By means of an ordinary camera a record of starlight can be obtained by pointing the camera at the pole-star, and thus the other stars trace circular arcs on the plate as they move around the pole.

The sunshine records of a station afford an idea of the average amount of cloud likely to be found in the neighbourhood of that station, but they give very little indication of the type of cloud or the height thereof, and for purposes of aviation it is very essential that these things be known. The relative humidity combined with

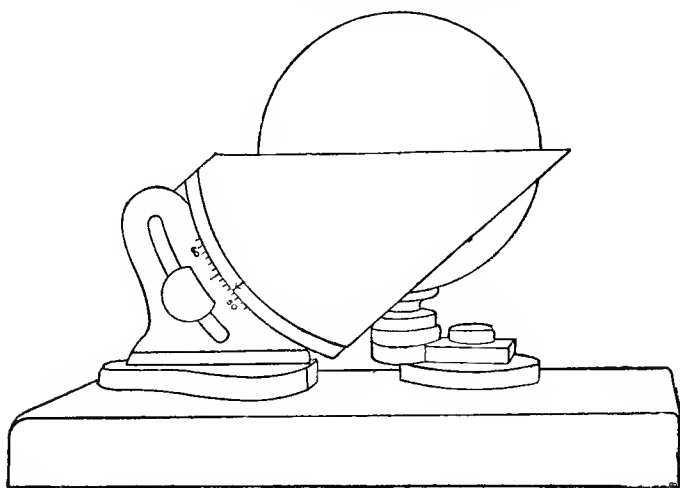

Fig. 60a.—Campbell-Stokes Sunshine Recorder (side view), showing Adjustment for Latitude

the sunshine records would afford a better idea of the general type of cloud to be met with, but the only sure way of obtaining a satisfactory record of cloud variation in type and amount at all hours is by eye observations.

A very interesting record of cloud observations was made by S. C. Russell¹ in Surrey, who maintained an hourly record for eight years, 1903–10, during which period over 100,000 observations were made. He divided his clouds into four groups, (1) upper clouds, (2) intermediate clouds, (3) lower clouds, and (4) clouds of diurnal ascending currents. Periods of cloudlessness are also considered. A large number of curves give the daily and annual variations of the different cloud amounts in his locality. For the conclusions

¹ *Quar. Jour. Roy. Met. Soc.*, Vol. XXXIX, p. 271.

arrived at by Mr. Russell, the reader is referred to the original paper in the *Quarterly Journal of the Royal Meteorological Society*.

Diurnal Variation of Cloud Amount.—The diurnal variation of cloud amount is irregular, but on the whole it shows a maximum just after midday, with a minimum in the late evening, about 22 h. The time of minimum is nearly constant throughout the year, but the period of maximum varies with the seasons occurring before midday in the winter and after midday in the summer. The afternoon maximum in summer is largely due to the formation of clouds of the cumulus type. During the winter the diurnal variation is not so well marked as it is in summer. If we consider the three-year period, 1916–18 for north-east France, the variation in cloud amount in January is 10 per cent of the possible, the minimum being 70 per cent at 20 h. and the maximum 80 per cent at 13 h. For the month of July the range is 24 per cent for the same period, a minimum of 54 per cent at 23 h., and a maximum of 78 per cent at 13 h.

The period of three years is sufficient to show the difference between summer and winter, but it is not sufficiently long to decide definitely the periods of maximum and of minimum, which are seen to differ from those given for average values extending over a number of years.

Annual Variation of Cloud Amount.—This depends considerably on latitude. In temperate zones the maximum occurs in winter and the minimum in summer, but any particular year may show large deviations from this general rule. The mean monthly values for 1916 for north-east France show a very distinct maximum in June, while the three-year period, 1916–18, indicates greater cloudiness in winter than in summer with a marked minimum in May.

TABLE XIV

Percentage of Total Cloud Amount over north-east France

Period	Jan.	Feb.	Mar.	Apr.	May	June	July	Aug.	Sept.	Oct.	Nov.	Dec.
1916	77	66	72	57	62	77	70	58	65	72	69	82
1916–18	76	67	69	71	57	67	67	67	65	70	77	74

In tropical regions on the other hand, the maximum is found to occur in July, whereas the minimum occurs in February. In India this is due to the south-west monsoons blowing from the Indian Ocean during the summer months, laden with water vapour. The ascent of the air on coming in contact with the land causes cooling, and hence condensation. On the other hand the dry north-east

monsoons prevail in the winter months, and the cold air coming down from the mountains to the plains is warmed in the process, so that very little cloud is formed.

Distribution of Cloud Amount over the Globe.—If the surface of the globe were uniform, then the cloud amount would be distributed very much in accordance with the pressure distribution. Over the Equator, where there is relatively low pressure and ascending moist air, there would be a cloud belt. This belt of cloud would diminish towards the regions of high pressure, where on account of the descending currents there would be very little cloud. Beyond these belts the moist warm air near the surface moving polewards would cause much cloud, until latitudes were reached where but little moisture remained in the atmosphere. In these polar regions, therefore, there would be comparatively little cloud, though probably some fog.

The unequal distribution of land and sea alters this theoretical cloud distribution, however, while the ocean currents also affect it considerably. On the whole there is more cloud over the oceans than over the continents. Over parts of North America, the Sahara, Arabia, and southern India, there are large tracts which are very cloudless. The same is found in the Southern Hemisphere over South Africa and Australia, the average cloud amount over these areas being about $\frac{2}{10}$ of the possible. Contrast this with the British Isles or north-eastern France, where the average amount is between $\frac{6}{10}$ and $\frac{7}{10}$. Coastal districts show a greater cloud amount than inland districts, a feature due to the lifting and consequent cooling of the moisture-laden air as it passes from above the sea to above the land.

The region of maximum cloud in the Northern Hemisphere is found over the North Atlantic and North Pacific oceans between lat. 50° and 70° N. In the Southern Hemisphere a belt of maximum cloud amount is found stretching round the earth between lat. 45° and 50° S.

FOG

Formation of Fog.—Fogs may be caused by smoke or by condensation of water vapour in the atmosphere or by a combination of the two. For smoke fogs there must be very little wind, and there must be a distinct inversion of temperature lasting over a considerable period of time so as to prevent convection. This

explains why smoke fogs are more common in winter than in summer, for during the winter-time the energy arriving at the earth's surface from the sun is not sufficient to destroy the inversion quickly, and the smoke screen once formed tends to maintain the inversion by preventing the radiation from reaching the surface of the earth. If, therefore, the general weather is of a quiet anti-cyclonic type, these smoke fogs may hang over a city for days, dispersing only when a more vigorous horizontal circulation of the atmosphere sets in.

Here, however, we shall consider rather the types of fog due to the condensation of water vapour. These arise through the direct cooling of the air which, as we saw, may take place in different ways; and first let us consider the formation of fog by the passage of a warm air current over a cold surface.

Fogs at Sea.—The diurnal variation of temperature at the surface of the sea is small, so that there is not a big temperature range in the air above it. But between two ocean currents, such as the Labrador current and the Gulf Stream, there is a considerable difference of temperature. Similarly, in the late spring and summer the difference in temperature between the continent of America and the cold Labrador current is very marked, so that air moving from above either the Gulf Stream or the American continent on to this Arctic current is moving from a warm area to a cold area, and the air near the surface is chilled and fogs result. A close study of the production of fogs in this area was made in 1913 by G. I. Taylor,¹ and he was able to trace the history of the air masses in which the fogs formed, and to show in the following way how these fogs were produced. He proved that the warm moist air coming in contact with the cold water surface was cooled down at the surface, so that the surface layer was coldest, and therefore densest, thereby preventing convection. But the cooling was gradually propagated upwards by eddy motion. The cooling at the surface, however, caused an inversion of temperature, and an observation by means of a kite in a thick fog on 25th July, 1913, showed that a maximum temperature of 292.5° A. occurred at 700 m. Above this height, temperature fell off according to the adiabatic gradient for dry air, 1° A. for 100 m. approximately, while below it, temperature fell to 284.7° A. on the surface, the temperature of the sea being 283° A. The humidity was 100 per cent from the surface

¹*Quar. Jour. Roy. Met. Soc.*, Vol. XLIII, p. 250.

to a height of 200 m., above which it decreased until 700 m. was reached, and thereafter remained constant at 85 per cent. The trajectory of the air, fig. 61, indicates that the mass of air which on 25th July was off Newfoundland, where the sea temperature was 283° A., was on the 19th July over a part of the sea where the temperature of the water was 300.2° A. This would indicate a

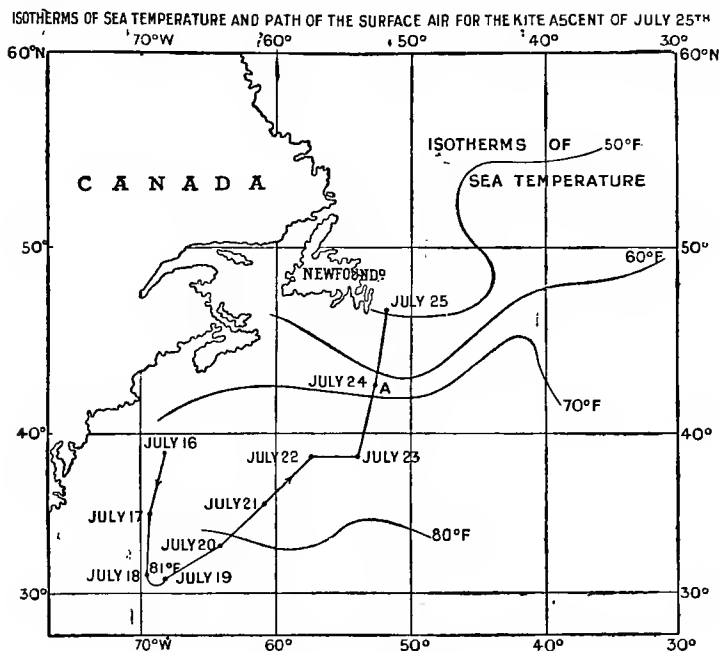

Fig. 61.—Isotherms of Sea Temperature, 25th July, 1913, and Path of Surface Air from 19th to 25th July (Taylor)

temperature of about 293° A. at 700 m., due to adiabatic cooling, and therefore the surface cooling in the period between 19th July and 25th July had extended only to 700 m. as the air mass moved northwards. The temperatures as found by Taylor are shown in fig. 62. The most general cause of sea fogs is this passage of warm moist air over a cold water surface, though cases have been noted of fogs occurring when the surface temperature of the sea is above that of the air in contact with it. The number of such fogs, however, is very much smaller.

Land Fogs.—Occasionally fogs drift in from the sea over the

land and, if the land is not warmer than the adjoining sea surface, the fog continues to rest on the surface, but, if the land be warmer than the sea, the fog rises and forms a stratus cloud. On the other hand, if the land be colder than the adjoining sea surface as in winter, a comparatively warm moist current coming in from the sea may cause a fog over the land. The explanation of the fog is similar to that where a warm moist current passes from a warm land area to a cold sea surface.

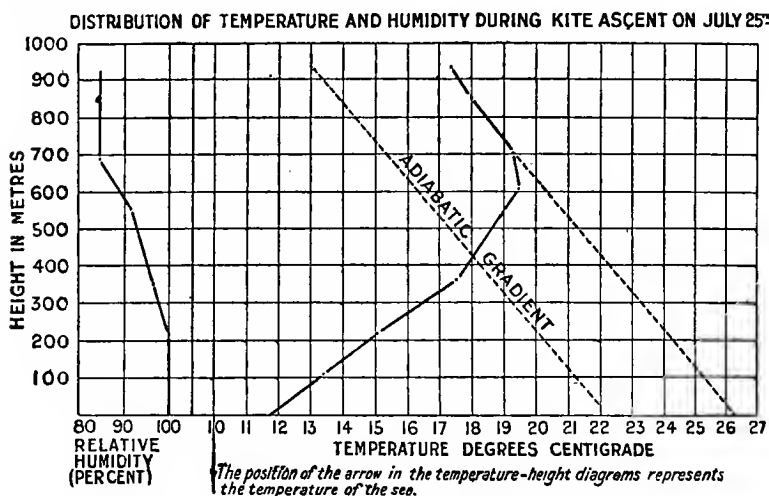

Fig. 62.—Distribution of Temperature and Humidity during Kite Ascent, 25th July, 1913 (Taylor)

Radiation Fogs.—Another type of fog which often occurs over land areas is the radiation fog. After a warm day on which the earth's surface has become heated, radiation sets in at night, and if the night be calm and clear, the surface cools rapidly so that the layer of air in contact with it falls in temperature. This cooling often extends only a very short distance up, especially on a wide flat plain. In valleys it extends farther, but this is mainly on account of the colder and therefore heavier air running down from the ridges into the valleys. Anyone who has motored over undulating country on a calm clear night is aware of the difference in temperature experienced on ridges and in valleys. As the air cools down, the saturation point is reached, and condensation takes place in the lower layers. Some of the condensed vapour is deposited on the ground as dew, and some of it continues suspended in the air as



Mist in the woods, the condensation of water vapour in the air

fog. This fog is often shallow, not exceeding 2 ft. in thickness over flat country. At other times it may extend to several yards above the surface, while in valleys it may be hundreds of feet thick. But in every case the temperature increases from the ground to a height well above the fog, the inversion thus formed preventing any convection currents. An example of fog or mist of this type is afforded by the photograph on Plate IX.

Conditions necessary for Radiation Fog.—(1) In order that fog may occur, the ground must not be too warm, otherwise the fall of temperature overnight will not be sufficient to cause the temperature of the air to fall below the dew-point. If the ground has been warmed up for several days on end, the chances of a fog occurring at night, even when all other conditions are favourable, is very much less. (2) The air must not be so dry that the cooling which takes place on a calm, clear night does not bring the temperature below the dew-point. (3) The wind must not exceed a limiting value. With a wind velocity greater than 3 miles per hour at midnight the chances of radiation fog are very small. (4) An inversion of temperature must be present.

Fog Prediction for Aerodromes.—As the result of an investigation of the occurrence of fog and of the weather conditions at the time, Taylor¹ has been able to devise a method of fog forecasting from the readings of the dry- and wet-bulb thermometers. The prediction is made by the aid of a diagram in which the abscissæ are the air temperatures and the ordinates are the differences between the dry- and wet-bulb thermometers. A neutral line runs across the diagram, and if the point obtained by observation falls above this line, the chances of fog during the night are very small, whereas, if it falls below the line, fog is very probable. The position of this neutral line varies according to the hour at which the observations are taken. In all cases the wind must be light, less than 5 miles per hour. Thus, if at 20 h. the temperature of the air is 45° F. and the difference between wet and dry bulbs be 4.0° F., the chances of fog during the night are small, whereas, if the difference be 2.0° F., fog is very likely to form, the critical temperature difference in this case being about 2.8° F.

Dew.—Large quantities of moisture are added to the atmosphere in the day-time on account of evaporation, particularly in the summer-time. With cooling at night the air reaches saturation-

¹ Loc. cit.

point, and any further cooling results in the amount of water vapour becoming greater than the air can contain, so that some of it condenses and is deposited as dew. A little moisture also comes up from the sub-soil and condenses as dew on the leaves of plants.

Conditions necessary for Formation of Dew.—As in the formation of radiation fog, a clear sky, and absence of wind are necessary. If the sky is overcast, radiation is prevented, and the earth's surface does not cool sufficiently. Much wind causes a mixing of the air, and so prevents any portion of it falling below the temperature of the dew-point. Before dew forms, an inversion of temperature almost always takes place just as in the case of fogs. Fogs form much more readily in valleys, both because the moisture in the air over the valleys is greater than over hills owing to the presence of rivers and lakes, and because the cold air drains down from the ridges into the valleys. So for the same reasons dew is formed much more frequently in valleys and in places where the air is still than on high and exposed ground where the air is in motion. Objects on which dew forms must be good radiators and bad conductors, so that they may radiate out their heat quickly to the sky and may not receive heat readily from the earth.

Frost.—Sometimes the temperature of the air has to fall below 273° A. before any of the water vapour in it is condensed. In that case the vapour passes directly from the gaseous to the solid state, and it is deposited as ice crystals. An examination of these crystals shows that they have not been deposited first as water drops, for they are not frozen drops of water. A deposit of this form is called *hoar frost*.

Hoar Frost and Rime.—Hoar frost must not be confused with *rime*, which is an accumulation of frozen moisture on trees, &c., and is *formed only during fog*. Hoar frost is the result of radiation at night. The writer can remember seeing an excellent example of rime at Hesdin, in north-east France, near Christmas time, 1917, during a spell of cold, foggy weather, when trees, telegraph wires, &c., became all covered with a thick layer of rime.

Glazed Frost.—In contrast to hoar frost and rime, which are white and opaque, *glazed frost* is a transparent smooth coating of ice covering trees, &c., and is usually caused by rain which freezes on falling to the ground. Another source is the moisture from a warm moist air current setting in suddenly over an area which has experienced intense cold for some time.

The corresponding terms for hoar frost, rime, and glazed frost, are in French, *rosée blanche*, *givre*, and *verglas*; and in German, *Reif*, *Duft*, and *Glatteis*, respectively.

C. PRECIPITATION

When a cloud forms through condensation of water vapour, minute droplets of water are first formed. These are kept in suspension or are carried higher up by the convection currents within the cloud, according to the activity of the currents. These droplets, through collision, coalesce to form larger droplets, and the stage is reached where the upward currents are no longer able to sustain them, whereupon they begin to fall downwards. As they descend they increase in size, as they are now passing through a layer saturated but warmer than they themselves are, and so more moisture condenses on them, their velocity depending on their size and the strength of the upward currents. When they issue from the base of the cloud they enter a layer which is no longer saturated, and where the temperature is higher, so that evaporation takes place. This evaporation may be so rapid as to prevent their reaching the surface of the earth, but if they are sufficiently big and numerous a certain number will reach the earth's surface, and then rain is said to be falling.

Size of Raindrops.—The size of the drops depends considerably on the temperature. Generally the drops are larger in warm countries than in cold climates, and also larger in summer than in winter. This is on account of the greater quantity of moisture present in the atmosphere under these conditions, and also by reason of the greater activity of the convection currents. The drops may be divided roughly into three classes—fine drops, medium drops, and large drops—the diameters of which are of the order 0.25 mm., 3 mm., and 6 mm. respectively. Raindrops of a larger size do not exist, for, according to experiments by Weisner, Lenard, and others, if a drop of 9 or 10 mm. diameter be allowed to fall from a height of even 22 cm. it breaks up into smaller drops.

Distribution of Raindrops in a Rainstorm.—All sizes of drops may be found in the same rainstorm, but the distribution of the various sizes is not generally uniform. Medium and large drops increase in frequency, according to observation, towards the centre of a storm, except in the case of thunderstorms. On the other hand

small drops appear to increase in frequency from the front to the rear of a storm. If the rain is falling from low, thin clouds, then small and medium drops are practically the only types present. Before drops of the large type are present the rain must fall from big complex clouds of the cumulo-nimbus order, so that they may have a considerable part of their path within the cloud, during which time they are continually increasing. According to W. A. Bentley, who has made a detailed study of various types of raindrops within rainstorms, the size of individual raindrops increases with the square of the mass of cloud passed through by the drop in its journey towards the earth.

Types of Rain.—Condensation, as we saw, took place through direct cooling, through expansion and consequent cooling, and to a less extent through mixing. Rain may also be divided into three main types: (1) rain due to the general circulation of the atmosphere and to diurnal convection currents; (2) rain due to obliquely ascending currents in cyclones; (3) rain due to the lifting of a mass of warm moist air by a mountain range. These types we shall consider separately.

Rain due to Convection.—At the Equator, where the air is damp and the convection currents active, there is a region of heavy rainfall. In the calm regions of the Horse Latitudes there is but little rainfall, as there the currents are mainly descending dry currents. These dry currents passing polewards over the oceans absorb at first large quantities of moisture, but as they are moving from a warmer to a colder area they become cooled down, and so they reach a point where precipitation takes place. This precipitation decreases in amount with increase in latitude, and within the polar circle the amount becomes comparatively small. The general circulation of the atmosphere therefore tends to produce a distribution of rainfall, showing a maximum at the Equator, two minima in latitudes 20° to 30° , maxima again in latitudes 40° to 50° , and thereafter a gradual decrease towards the poles. This general distribution, however, is considerably altered by the unequal division of land and sea. In mean latitudes the effect of diurnal convection currents is seen, in that it causes the maximum in the rainfall curve for the day to appear during the afternoon in the summer months, whereas in the winter months, when convection is very slight, no such marked maximum is to be found.

Rain due to Cyclones.—Rains of this type are mainly confined

to the temperate zones, as cyclones are of comparatively rare occurrence in equatorial regions. On this account, therefore, the rainfall distribution within the temperate zones may be entirely different from what would result from the general circulation of the atmosphere. The latter would indicate a greater rainfall over France than over the British Isles and Scandinavia. But as the main track of the depressions or cyclones coming from the Atlantic passes to the north-west of the British Isles, the amount of rainfall due to these cyclones outweighs this diminution, so that the annual rainfall on the western coasts of the British Isles and Norway is greater than that on the western coasts of France.

Rain of this type is apparently mainly due to the lifting up of the warm moisture-laden south-west currents by the colder north-easterly currents, thus causing condensation and precipitation.

Rain due to Mountain Barriers.—When a current of air, moisture-laden, strikes a mountain range it is forced upwards, a result which tends to cause condensation and precipitation, especially on the windward side of the mountain range. An example of this is afforded by the western highlands of Scotland, where the south-west currents from the Atlantic are forced upwards and precipitation produced. On the Pacific coasts of North America this effect is even much more marked. The air-current on descending on the other side of the mountain range is warmed by compression, and as part of its moisture has been precipitated it is much drier than when it approached the land. Districts on the leeward side of a mountain range are thus in general much drier than those on the windward side. The prairies of Western Canada serve as an example.

A mountain range does not alter the total amount of rainfall over a large area, but it tends to alter the distribution of that rainfall. Thus the distribution tends to follow the contours of the country, but with this difference, that the lines of equal rainfall are shifted windwards in relation to the contours.

Measurement of Rainfall: The Rain-Gauge.—In Chapter I reference was made to the invention of the rain-gauge in Europe, and also to the early rain-gauges used in Korea.

At the present day various types of rain-gauge are used. The type in general use at stations in the British Isles is the 5-in. gauge shown in fig. 63. It consists of three portions: the funnel, which can be removed; a cylindrical portion with flanged base, which is

let into the ground; and thirdly, an internal receiver. The whole consists of copper. Round the top of the funnel is a stout copper band to prevent deformation. The vertical portion of the funnel, which is 6 in. long, is intended to serve in the case of snow and also to prevent splashing in heavy rain. This pattern of gauge differs from the Snowdon gauge in that the receiver is of copper instead of glass. The height of the top of the funnel above the ground should be 12 in., and the gauge should be exposed in a position where the rainfall will not be affected by surrounding objects.

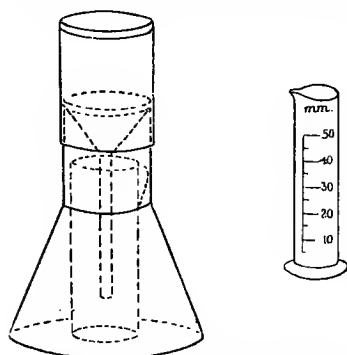

Fig. 63.—Rain Gauge and Measuring Glass

At climatological stations observations of rainfall are made daily at 9 h., and at telegraphic reporting stations twice daily at 7 h. and 18 h. The rainfall is measured by means of a measuring-glass of the type shown in the figure. At observatories the 8-in. gauge is commonly used in place of the 5-in. gauge.

Automatic Recording - Gauges.—These are used to obtain a continuous record of rainfall, and the Beckley gauge, which has a diameter of 11 in., will serve as an example. Here the rainfall is allowed to collect in a receiver, which is supported by a float in mercury. The receiver gradually sinks as the weight of water increases, until an amount equivalent to a rainfall of 5 mm. has been collected in the receiver, when, by means of a syphon, the whole is syphoned out, and the receiver rises to its zero position again. Attached to the float is a pen which traces a record on a chart placed on a revolving drum. When the receiver

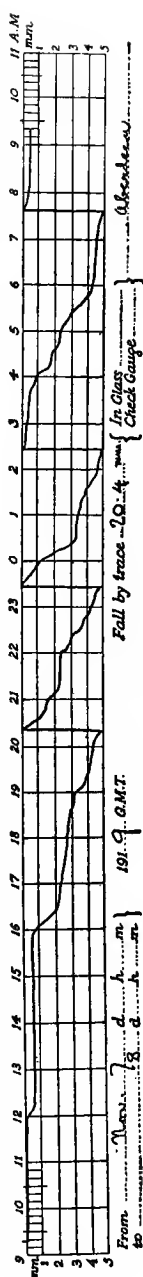

Fig. 64.—Rainfall Trace

empties and rises to its zero position, the pen traces at that instant a vertical line on the paper. A trace of the rainfall for 7th to 8th November, 1919, at Aberdeen, is shown in fig. 64.

Diurnal Variation in Rainfall.—By the measurement of curves, such as fig. 64 represents, the value of the rainfall for every hour can be obtained.

The mean values for the months of January and July, compiled from the observations of the forty-year period 1871–1910, are represented graphically in fig. 65. The curves represent the values for Aberdeen and Kew. The January curves are very flat, though there

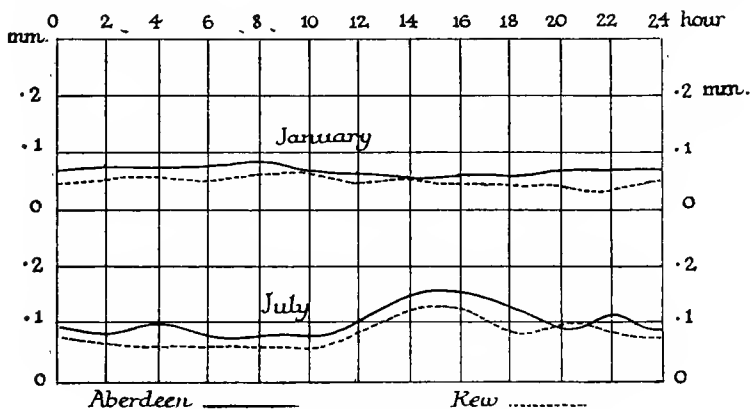

Fig. 65.—Diurnal Variation in Rainfall—Period 1871-1910

is a tendency, especially in the case of the Aberdeen curve, to show a greater rainfall at night than during the day. The outstanding feature on the July curves is the afternoon maximum. There is no sign of this maximum on the winter curve. The time of its occurrence is from one to two hours after the time of maximum temperature, a time at which convection is slackening down considerably. The maximum is, therefore, due to the rainfall from clouds arising from diurnal convection, the rain being largely of the thunder-shower type.

Annual Variation in Rainfall.—The curves showing the annual variation in rainfall indicate that for stations in the same latitude the distribution of rainfall depends very largely on the geographical situation. The stations of Kew and Valencia are practically on the same parallel of latitude, and yet the rainfall at the latter is every-

where more than double, and in several months treble, the amount at the former. The first five months of the year are comparatively

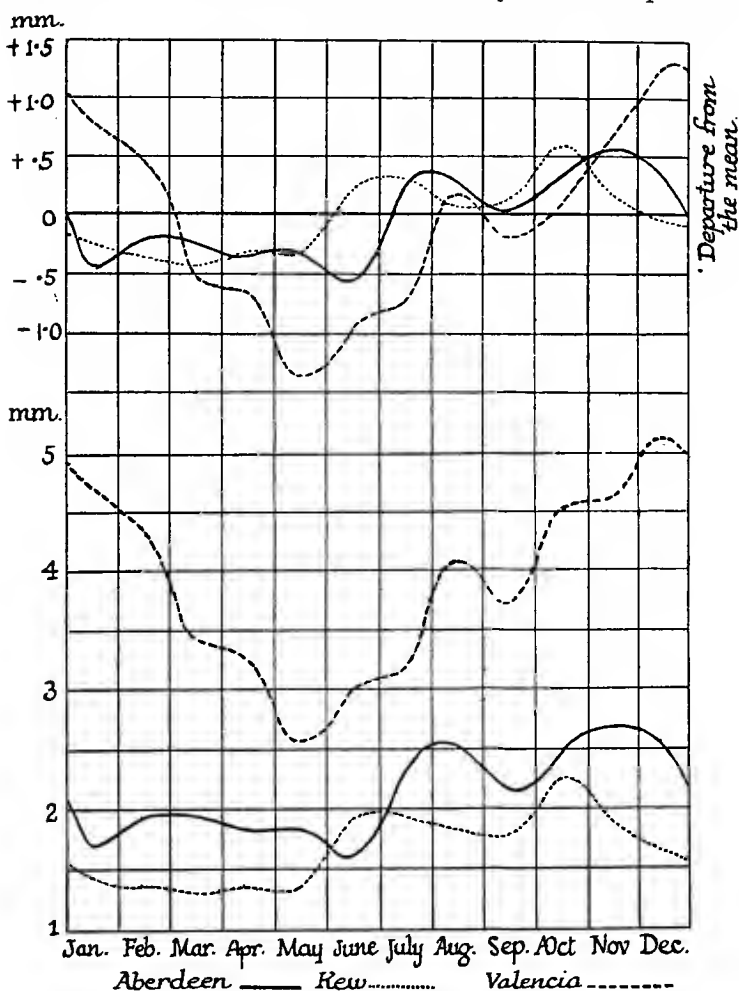

Fig. 66.—Annual Variation in Rainfall and Departure from the Mean

Mean values at Aberdeen, 2.13 mm. Mean values at Kew, 1.66 mm.
Mean values at Valencia, 3.91 mm.

dry months at Kew, and throughout the whole of that period the rainfall is below the mean for the year. At Valencia, on the other hand, there is a rapid decrease during these months, the minimum for the year occurring in May. The dry period at Valencia is from

March to July inclusive. The excessive rainfall at Valencia is due to the rains from depressions. In the winter season the mean path of the Atlantic depressions is farther south than in summer, and as the rainfall is greater nearer the centre of a depression than on its extreme edges, the amount of rain received at Valencia in winter is therefore much greater than in summer. Great similarity, however, exists between the curves for Kew and Aberdeen. Both show a dry period during the first five months, and a wetter period from July to December. Both stations are on the eastern side of the high ground which runs along the whole of the western coasts from north to south, and so the moisture from the south-west currents is precipitated to the westward of these stations. The increase during the months of July and August is apparently due to rainfall of the thunder-shower type, i.e. rain caused by diurnal convection currents. The increase in the late autumn months is accounted for by the precipitation, from the south-west currents on the southern side of the Atlantic depressions. The difference in temperature between land and sea is now considerable, and these south-westerly currents are heavily laden with water vapour on account of the temperature of the sea, so that when they reach land the rainfall from them is considerable. The high ground on the western coasts is in itself not now sufficient to precipitate the whole of the water vapour, and as the currents advance farther over the land, they become cooled down and yield further precipitation. At all three stations the month of September shows a minimum. This may be explained through the rainfall which is due to the diurnal convection currents of July and August having decreased considerably, and that due to the passage of cyclones not having commenced. September is on the whole, therefore, a very settled month.

Isohyets.—Just as lines of equal pressure and lines of equal temperature can be drawn over an area, so lines can be drawn over an area to include districts where the rainfall is equal. These are known as Isohyets, and they were the first method of representing rainfall distribution. Since then other methods have been introduced, and one method suggested by Mill was to use the cyclone as the unit.

The first rainfall map for Europe was published in 1845 in Berghaus's *Physical Atlas*, and the first chart for the world was drawn in 1882 by Loomis. This was later redrawn by Buchan.

The most complete set of rainfall maps for all parts of the world is to be found in Bartholomew's *Physical Atlas*.

Distribution of Rainfall over the British Isles.—The annual isohyets for the British Isles are represented in Chart IX. At a glance it is seen that the rainfall is much heavier on the western coasts than over the eastern districts. This is particularly noticeable in the western highlands of Scotland where the mean annual rainfall is over 2000 mm. This heavier rainfall is common to all the months, and is in great part due to the raising up and consequent cooling of the warm moist south-west currents from the Atlantic. Also the mean path of the cyclones from the Atlantic passes along the north-western coasts of these islands, so that the rainfall is accentuated thereby. On the eastern side of the mountain ranges the rainfall is very much less, the value on the Scottish coasts being between 750 and 1000 mm. annually, while over central England it lies between 635 and 750 mm. In the fen country the annual precipitation is less than 635 mm., and at the mouth of the Thames it is under 600 mm. The föhn effect as the winds descend from the mountain ranges on the western side to the eastern plains is therefore well marked.

A very accurate idea of the rainfall distribution over the British Isles has been obtained through the work of the British Rainfall Association now merged in the Meteorological Office. The work was organized by the late Mr. G. J. Symons, F.R.S., and Dr. H. R. Mill, who after the former's death assumed the direction of the investigation. The results are published each year in *British Rainfall*, and represent measurements made at over 5000 stations throughout the Kingdom.

Distribution of Rainfall over the Surface of the Globe.—The general distribution of rainfall over the globe is such as to give a maximum near the Equator with an irregular decrease towards the poles, but to this general rule there are many exceptions. In the Northern Hemisphere, over large tracts of Africa and Asia, the rainfall is very light, the mean annual value in the Sahara, Arabia, north-west India, the Desert of Gobi, and over regions north-east of the Caspian, being under 250 mm. Australia and south-west Africa in the Southern Hemisphere have a like rainfall. In America the dominating factor in the west is the mountain chain running from north to south of the continent. On the western side in British Columbia the rainfall decreases from 2000 mm. on the coast to

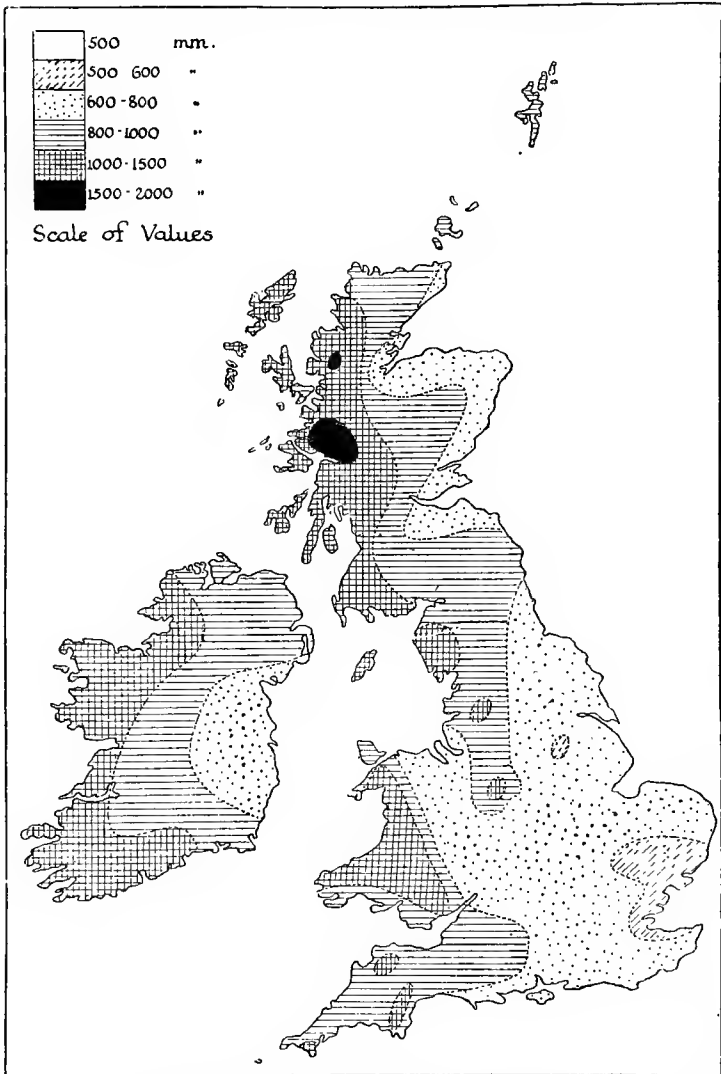

Chart IX.—Annual Mean Rainfall over the British Isles based on values for the period 1876-1910. Adapted from the chart in M.O., 214a, Appendix IV.

300 mm. on the mountain ridges. The same occurs on the coasts of Chile. Over the western Canadian prairies the rainfall is only about 350 mm. annually, while over Patagonia on the eastern side

of the Andes the annual rainfall is less than 250 mm. The moist currents coming from the ocean are deprived of their water vapour on passing over the mountains, and descend on the eastern side as dry winds. In Canada these winds are known as chinook winds, and have the same properties as the föhn winds descending over France from the Alps.

Areas where the rainfall is heaviest are found in the regions of the monsoons. Over Eastern India, Burmah, and Cochin-China the annual rainfall is between 3000 and 4000 mm.

If the prevailing winds over an area are blowing from a colder region to a warmer, then the rainfall over that area is comparatively light. Spain and north-west Africa serve as an example, for there the prevailing wind is from the west or north-west. Over the rest of western Europe the prevailing winds are south-westerly, and so the rainfall is much heavier. The rainfall over the north-west coasts of Europe is in great measure due to the passage of cyclones from the Atlantic.

On the coasts of Norway within the Arctic Circle the annual rainfall is 1000 mm., whereas in the same latitude in Siberia it is less than 250 mm.

South America, except in the regions dominated by the Andes, has on the average, a greater rainfall than North America. The whole of the valley of the Amazon has a rainfall amounting to 2000 mm. annually. This precipitation in the Amazon valley forms part of the equatorial belt of rains, and though part of it is due to the water vapour carried in from the ocean by the trade winds, the rich vegetation along the whole valley also supplies large quantities of vapour to the atmosphere.

Distribution over the Oceans.—Turning now to the oceans we find that over the Atlantic there are two areas of heavy rainfall, one along the Equator stretching from Africa to South America, and another between Newfoundland and the British Isles, each with an average rainfall of over 2000 mm. annually. The rainfall over the first region is due almost entirely to convection, whereas the rainfall over the second region is mainly of cyclonic origin. In the Indian Ocean the region of heavy rainfall stretches between Madagascar and Australia, the amount there being also of the order of 2000 mm. annually. This is the region in which tropical cyclones of the southern Indian Ocean occur. The mean annual rainfall for the globe is shown on Chart X.

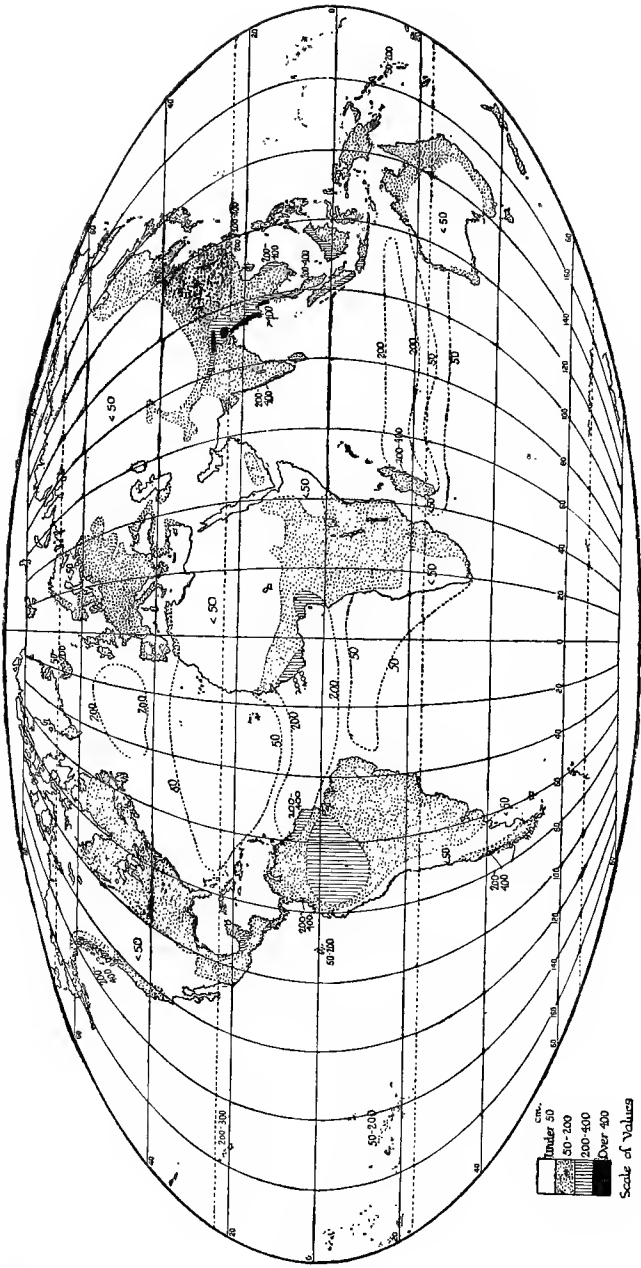

Chart X.—Mean Annual Rainfall (after Herbertson and Supan)

Snow.—In the adiabatic diagram we saw that cooling below the temperature of 273° A. resulted in the production of snow, i.e. the water vapour passed directly from the vapour condition to the solid state. The vapour solidifies in crystals more or less regular, either simple or complex. Examples of the framework of these crystals are shown in fig. 67.

Snow Crystals and Snowflakes.—When the temperature is very low, under 250° A., then the snow falls in crystals, each crystal being separate. Above this temperature the crystals unite to form snowflakes, which appear very irregular, but when closely examined

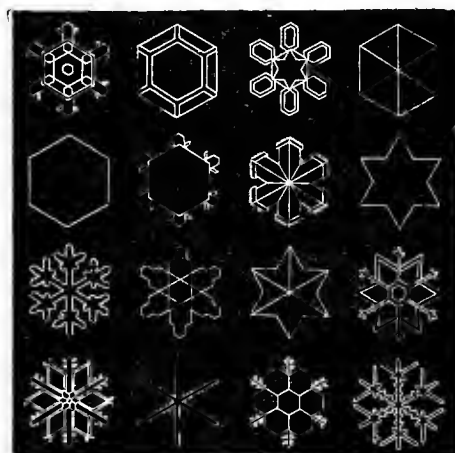

Fig. 67. — Snow Crystals

are seen to consist of a large number of snow crystals. In the flakes the crystals are often incomplete, as parts become melted off on account of the temperature at which the snow is falling. The most detailed study of snow crystals is perhaps that of W. A. Bentley, who has obtained over 1000 microphotographs from observations extending over a period of 17 years. He divides them into two main classes,

columnar and *tabular*, and further into various subclasses. He uses the term *lamellar* to denote solid tabular forms, and *fern stellar* to denote those with an open structure resembling ferns, but with a solid tabular nucleus. Long needle-shaped columnar forms he calls *spicular*, while columnar forms in which two tabular forms are connected by a spicule are designated *doublets*.

Water Equivalent of a Snowfall.—In order to obtain an idea of the water equivalent of a snowfall, the depth of the snowfall may be measured. This method, however, gives only a rough approximation, for large quantities of air are included in the interstices between the crystals, and the size of these spaces depends largely on the size of the snowflakes. On an average newly fallen dry snow gives a water equivalent of about $\frac{1}{10}$ its own depth.

Snow that has lain for some time may give a yield as high as $\frac{3}{10}$ its thickness. If the temperature of the air be near 273° A. during a snowfall, then often rain is mixed with the snow, so that no idea of the real amount of precipitation can be obtained through measuring the depth of the snow. Before an accurate value can be obtained, therefore, it is necessary to melt all the snow that has been caught in the gauge, thus obtaining its value in millimetres of water.

Snowfall Distribution.—Between the Equator and lat. 30° snow is practically unknown at sea-level, though it is quite common at high altitudes in these latitudes, and even perpetual snow is found on the Andes in lat. 0° . Between lat. 30° and 40° it is of rare occurrence at sea-level, but snow does occasionally fall on the northern coasts of Africa, in Florida, and at Athens. Farther inland and on high ground it is quite common, as in Palestine, Mesopotamia, and the southern states of America. In these latitudes are found also the perpetual snows of the Himalayas. Between lat. 40° and the poles, snow is common at all levels during winter, with perhaps the exception of the northern shores of the Mediterranean, where it is but seldom experienced. Its distribution over areas where it is of common occurrence is similar to the distribution of rainfall. Over eastern Canada it is a maximum on the Atlantic border and decreases towards the western prairies. Over Europe the snowfall is heavier on the western shores than over the central regions, though, on account of the differences in air temperature, the coastal regions are not covered with snow for the same length of time as the central regions are. In general, therefore, the snowfall is greatest over areas bordering on the oceans, and least over continental areas.

Perpetual Snow.—An interesting point in the study of snowfall distribution is the limit of height above which the snow never disappears from one year's end to another. This limit is known as the limit of "perpetual snow". At first one is apt to think that there must be a direct relation between the annual mean temperature and this limit of perpetual snow, but a closer examination shows that this is not so. In some districts where the annual mean temperature is below 273° A., perpetual snow does not exist, e.g. in parts of Siberia where the annual mean temperature is 257° A., whereas it is found in certain regions where the annual mean temperature is above 273° A. The annual *range* of temperature, therefore, seems to play a considerable part in the determination of

the limit of perpetual snow, though there are a number of other causes affecting this limit. The amount of the snowfall is a large factor in determining this limit. On the side of a mountain range on which the fall is heavier, the limit is lower than on the other, even though this side is the side nearer the Equator. Similarly, in districts where the humidity is high and the precipitation large, the snow-line is lower than in dry regions. The snow-line advances and retires with the seasons over those regions where seasonal variation of temperature takes place, but over the Equator, where the temperature is practically constant all the year round, the snow-line shows very little change. There appears also to be a slow secular change in this limit of perpetual snow, but, as observations have only been taken over a comparatively short time, and at comparatively few stations, very little can be stated definitely about this change.

Hail.—Another stage in the adiabatic diagram was designated the hail stage. During this stage the water vapour which had condensed into waterdrops was frozen, while the temperature remained at 273° A. These frozen drops of water constitute "fine hail", and act as nuclei for the larger "hail" or "hailstones". The small type of hail consists of small masses of ice, white and opaque.

This opaqueness is due to the inclusion of air in the mass. When the raindrop freezes, the air it contains separates out, filling the interstices in the hailstone between the particles of ice, and so rendering it opaque.

TYPES OF HAIL.—Fine hail, where the diameter of the hailstone lies between 1 and 3 mm., is for the most part spherical, but larger hailstones, though often showing a spherical form, exhibit a variety of shapes and sizes. The cone-shaped hailstone is a very common type in this latitude. It appears to be due to the bursting of a larger mass more or less spherical in shape. Hailstones of this type have a diameter of 4 or 5 mm. Sometimes a regular crystalline form is exhibited by hailstones, as in fig. 68, and in this form they have at times diameters as large as 9 cm. Occasionally large masses of ice fall weighing several pounds, but the occurrence of such is very rare.

SECTION OF A LARGE HAILSTONE.—If the section of a large hailstone be examined, the central portion is generally found to consist of a fine hailstone acting as nucleus to the rest. Round this central portion is an envelope either of opaque ice or of concentric shells

consisting alternately of opaque ice and transparent ice. The larger types are often covered on the outside with a layer of regular ice crystals. Some hailstone sections are shown in fig. 68, and the crystalline form of the outer covering is well seen in No. 4.

LIFE HISTORY OF A HAILSTONE.—An examination of the cross-section of a hailstone enables one to determine the approximate temperatures of the layers of the atmosphere through which the hailstone has passed. The opaque layers indicate that the water vapour has condensed as water drops, and the water drops become supercooled. When the small hailstones enter such a layer and

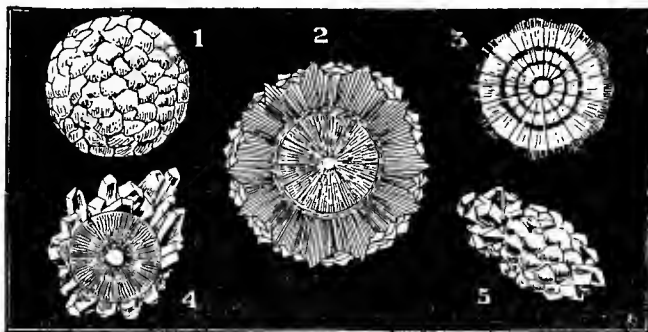

Fig. 68.—Hailstones

1, Soft hail. 2 and 3, Sections of hailstones showing the cores of snow. 4 and 5, Remarkable types of crystalline forms. 1, 2, and 3 are enlarged.

come in contact with the waterdrop, sudden freezing takes place and small quantities of air are included in the layer, rendering it opaque. The transparent crystalline layer, on the other hand, is built up gradually from the vapour in the atmosphere, through the hailstone remaining a considerable time in a layer of air where the temperature is considerably below 273° A. As the convection currents alter in strength, the hailstone may be carried up and fall back several times through such layers of air as indicated above, each passage adding to its size, until by its weight it is able to overcome the upward force of the convection currents and to fall to the earth. Strong convection currents are, therefore, essential for the production of hail, and so hail often accompanies thunderstorms. In these storms the convection currents are sufficiently strong to maintain the drops of water in a region where they become frozen,

and afterwards increase in weight until they finally fall to the earth.

Distribution of Hail over the Globe.—Fine hail practically never occurs in equatorial regions, as the temperature of the surface layers is too high. In mean latitudes it is comparatively common in winter-time, but it is met with most frequently in the polar regions and particularly during the winter period. In this respect it differs from hailstones or hail of the large type, for the latter is scarcely ever found within the polar regions. Hail of this type occurs most frequently in mean latitudes, and its greatest frequency is during the late spring and summer, i.e. during the period of thunderstorms. Large hail falls also in tropical latitudes, though its frequency at sea-level is small. This is due to the temperature of the lower layers of air, which causes the hailstones to melt so that the precipitation falls as rain. But at altitudes in these regions where the temperature is much lower, hail showers are by no means infrequent.

CHAPTER VII

The Minor Circulations of the Atmosphere

In studying the general pressure distribution at the surface of the earth, we found that pressure was permanently lower in the neighbourhood of the Equator than in lat. 25° to 30° on either side of it. Two other areas of permanently low pressure exist, one in the vicinity of either pole. In mean latitudes there is a gradual diminution of pressure from the high-pressure belts near the tropics to these low-pressure centres round the poles.

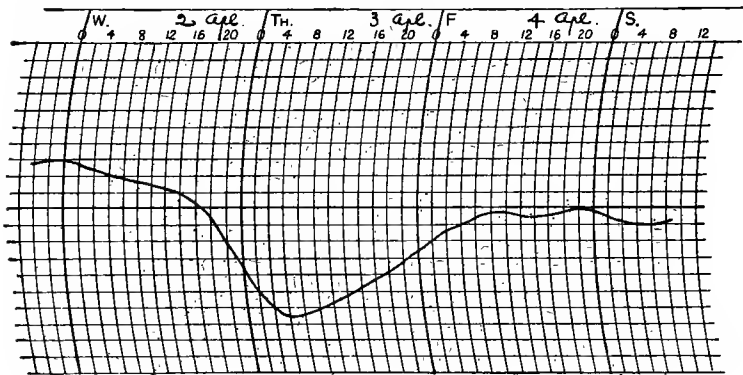

Fig. 69.—The Passage of a Depression

Also a diurnal variation in pressure was shown to take place, very pronounced in equatorial regions, gradually decreasing in intensity with increase in latitude, and practically vanishing in polar regions. This, however, does not represent the whole variation of pressure which takes place especially in mean latitudes.

A Barometric Depression.—If a continuous record of pressure be maintained by means of a barograph, it is found, particularly in mean latitudes, that the pressure is continually rising and falling, and that the variations are very large compared with the

regular diurnal pressure variations. Such a variation is shown in fig. 69, which indicates the rise and fall of pressure at Aberdeen from 2nd April to 4th April, 1919. This rise and fall of pressure is due to the passage of what is known as a Barometric Depression or a Cyclone. The term cyclone was first given by Piddington, and was used with reference to the tropical storms occurring in the Bay of Bengal and the Arabian Sea. The name is derived from the Greek word $\kappa\upsilon\kappa\lambda\omicron\varsigma$ = a circle, and it was meant by Piddington to convey the idea, not that the motion in these storms was exactly circular, but that the air moved spirally round the centre. Piddington always insisted that the air in these tropical cyclones tended to flow inwards on the surface towards the centre; but this fact seems to have been lost sight of, and some of the earlier writers, in treating of cyclones, regarded the motion as taking place in circles.

Cyclones.—The study of Cyclones became possible after the introduction of synoptic charts by Brandes, who published in 1820 the results of his investigations obtained by means of these charts from the observations of weather conditions made during the year 1783. The conclusions arrived at by Brandes may be summarized under four heads as follows: (1) The direction of the wind at any instant is determined by the barometric distribution in such a way that the air is drawn in towards the centre of a depression, with a deviation to the right of the direction strictly centripetal. (2) Depressions move in general from west to east across Europe. (3) The changes in weather are bound up with the variations in pressure and the direction of the wind. (4) For the study of depressions and storms associated with them, he proposed the organization of a meteorological service.

In America Redfield was the first to publish a series of papers demonstrating what was then called the Law of Storms. This was in 1831, and since that time many investigators, among whom may be mentioned Dove, Piddington, Espy, Ferrel, Hann, Bigelow, and Shaw, have written much regarding both tropical and extratropical cyclones, and various theories have been advanced regarding their origin, maintenance, and motion. Cyclones may be divided into two main classes, tropical and extratropical, the general features of both being similar, though there are very marked differences in detail. In both, the pressure decreases from the outside towards the centre, and the strength of the wind is

dependent on the rate of this decrease. The wind circulation is the same in both, counter-clockwise in the Northern Hemisphere and clockwise in the Southern Hemisphere. Round the centre of low pressure the air moves in spirals after the manner shown in fig. 47, page 133. As it approaches the centre it tends to rise up, but this vertical component is very small as a rule compared with the horizontal components. The effect of this vertical motion is to cause expansion and consequent condensation and precipitation, and the energy liberated through this condensation goes towards the maintenance of the cyclone. First let us consider extratropical cyclones or cyclones of mean latitudes, generally called "depressions".

A. EXTRATROPICAL CYCLONES OR DEPRESSIONS AND ANTICYCLONES

CYCLONES

Characteristics of a Depression.—These have been indicated in part already, viz. a low barometric pressure near the centre, with winds blowing spirally inwards towards the centre, counter-clockwise in the Northern Hemisphere and clockwise in the Southern. Depressions are generally accompanied with much cloud and precipitation, though this is not invariably the case. They are always warmer in front than in the rear, as the front is fed by currents moving polewards, whereas the rear is supplied by currents moving towards the Equator. For the same reason the precipitation is greater in the front half than in the rear half. The air in front of a depression is close and muggy, whereas, behind it, it is clear and bracing.

Extent of a Depression.—Depressions vary considerably in size, but the diameter of an average cyclone is about 1000 miles. Some have a diameter as large as 2000 miles, and others may extend to only 100 miles across. As the height of the troposphere is only 8 or 9 Km., i.e. 5 or 6 miles, while at 20 Km., or $12\frac{1}{2}$ miles, above the surface pressure is everywhere uniform, it is at once evident that the thickness of a depression is very small compared with its lateral dimensions.

Distribution of Pressure in a Depression.—If simultaneous observations of pressure be made over an area across which a depression is passing, and these observations be reduced to a common level, say sea-level, and thereafter be plotted on a chart,

it is found that a system of isobars can be constructed showing a limited area over which the pressure is a minimum. From this point the pressure increases outwards in every direction to the boundary of the depression, though the increase is not necessarily uniform in all directions. Such a system is shown in Chart i, fig. 76 (p. 219); which represents the pressure distribution over the British Isles at 18 h. on 12th November, 1915. At that time the pressure at the centre was less than 960 mb. At 21 h. on the same evening the distribution of pressure is indicated on Chart ii, and the central isobar was then 965 mb. Thus as the centre moved from position No. 1 to position No. 2, the minimum of pressure had also changed, indicating that the system not only moved as a whole but that the distribution of pressure within the system was also continually changing. If the pressure at the centre is continuing to decrease, the depression is said to be "deepening", whereas if the pressure be increasing, as in the case considered, the depression is said to be "filling up".

The line joining the successive points of minimum pressure is called the "path of the centre". This line is seldom a straight line, for there are a variety of causes which tend to alter the direction of motion of a depression, and occasionally this line curves back on itself. A line drawn perpendicular to the path of the centre at any instant and passing through the centre is known as the "trough" of the depression, so that at the instant this line passes over a station, the barograph at that station shows a minimum. Fig. 69, which gives the continuous record of pressure at Aberdeen from 2nd to 4th April, 1919, indicates that the trough of that depression passed over the station at 7 h. on Thursday, 3rd April. All stations, therefore, which find themselves on the trough-line at the same time will also show minimum pressure at the same time. Behind the trough pressure begins to rise again, and the rate of rise in any given depression will depend on the distance of the station from the centre.

The portion of the depression in front of the trough is called the "front", and the section behind, the "rear". These two portions are again divided into the "front right" and the "front left", the "rear right" and the "rear left", the direction of the path of the centre acting as the dividing line. The depression is so divided because there are considerable differences in the weather experienced in the four quadrants.

Intensity of a Depression.—In mean latitudes pressure seldom falls below 955 mb., and even this value is rare, occurring perhaps only once or twice in a year. Lower pressures, however, have been recorded. On 26th January, 1884, a depression crossed the British Isles in which the pressure fell to 925 mb., but such values are extremely rare. The depth of a depression does not, however, in reality measure its intensity. This depends upon the closeness of the isobars to each other, so that the intensity is measured by the difference in pressure between the centre and the boundary, divided by the distance between these points. The intensity differs in different parts of the depression, being generally greater in front than in the rear. In a normal depression the difference in pressure for 69 miles or 1° of a great circle, i.e. the horizontal pressure gradient, is about 5 mb. This value is frequently surpassed, and in very intense depressions reaches 15 mb. or 16 mb.

Distribution of Wind round the Centre of a Depression: GEOSTROPHIC WIND.—In the general circulation of the atmosphere with the wind moving in great circles, the relation between the pressure gradient and the velocity of the wind to a first approximation was found in Chapter V to be

$$\gamma = 2 \omega VD \sin \phi,$$

where γ = the barometric gradient, V = the velocity of the wind, ω = the angular velocity of the earth, D = the density of the air, and ϕ = the latitude. This relation arises on account of the rotation of the earth,

and in consequence has been called the geostrophic relation, and the wind caused by the force the geostrophic wind.

But the curvature of the path of motion of the air in a depression is considerable, especially near the centre, so that for a complete solution of the problem, account must be taken of the centrifugal force caused by the motion, as well as the force due to the earth's rotation. The deviation of the direction of the wind from that of

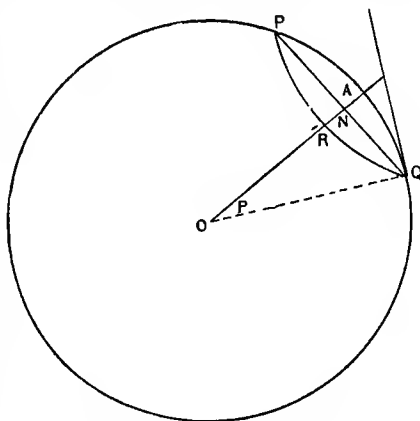

Fig. 70.—Effect of Curvature of Path

the isobars is comparatively small, so that the centrifugal force due to motion can easily be calculated to a first approximation.

For let PQR, fig. 70, represent an isobar of the cyclonic system of which A is the centre, and let PQ meet OA in the point N. Then the acceleration of a particle moving with uniform velocity V on the circumference of the circle PQR is V^2/PN along PN, or $V^2/R \sin \rho$, where R is the radius of the earth, and ρ the angular radius of the small circle representing the path. The component of this acceleration along the tangent, i.e. along the surface of the earth, is $\frac{V^2}{R \sin \rho} \times \cos \rho = \frac{V^2}{R} \cot \rho$.

CYCLOSTROPHIC WIND.—If the motion in a depression is taking place in very small circles, then the gradient is practically balanced by this centrifugal force, and the wind caused by this centrifugal force is known as the “cyclostrophic wind”.

GRADIENT WIND.—Now in depressions in mean latitudes the pressure gradient is balanced partly by the force due to the earth's rotation and partly by that due to the motion in the depression. Consequently if the air is to continue moving along the isobars, the following relation must hold,

$$\frac{\gamma}{D} = 2 \omega V \sin \phi + \frac{V^2}{R} \cot \rho.$$

This relation gives the “gradient wind” in a depression.

In large depressions in mean latitudes the curvature of the isobars is small, and also V and V^2 are small in comparison with R, the radius of the earth. Hence the second term on the right hand side of the above equation is small, and in comparison with the first term may be neglected without causing any serious error. The geostrophic wind is in consequence very often regarded as the gradient wind in such depressions.

For regions in the neighbourhood of the Equator, however, ϕ is small and hence $\sin \phi$ is small, so that the first term becomes negligible in comparison with the second. Storms in tropical regions are generally much smaller in diameter than those of mean latitudes, so that the curvature of the isobars is greater, and the velocity of air in the storm is much greater, and therefore the second term is no longer a small quantity. The pressure gradient in such storms is then practically balanced by the force which the second term expresses, and the cyclostrophic wind is in this case a close approximation to the gradient wind.

Deviation from Geostrophic Wind in Direction.—As already stated the relations considered above have been arrived at on the assumption that the direction of motion of the air is perpendicular to the direction of the pressure gradient. Now observation of wind direction at the surface of the earth shows that this is not the case, but that the wind tends to blow in towards the centre of low pressure. Careful investigations have been carried out both in Europe and in America with a view to determining the amount of this deviation, both at the surface and in the upper layers of the atmosphere. As a result it is found that the deviation from the gradient wind direction is on an average from 20° to 25° on the surface, being slightly greater in front of the depression than behind it. But this deviation is by no means constant throughout the day. It is larger at night than during the day-time especially over the land, for reasons already set forth in Chapter V.

Deviation over the Sea.—Over the sea the deviation from the gradient wind direction is less than over the land, mainly on account of the greater force of friction experienced in passing over land areas. Also the diurnal variation of temperature is less over the sea than over the land, so that the diurnal variation in the deviation is likewise smaller. Over the North Sea the deviations of the surface winds from the directions of the geostrophic winds, as given by Shaw, are set forth in the following table.¹

TABLE XV

Relation of Surface Wind to Geostrophic Wind (between 8.5 m/s and 18 m/s)
over the North Sea

Percentage frequency of points in the Veer of the Geostrophic Wind from the
Surface Wind

Deviation in Points	-4	-3	-2	-1	0	+1	+2	+3	+4	+5	+6	+7
	%	%	%	%	%	%	%	%	%	%	%	%
N.W. Quadrant	0	1	0	2	21	32	<u>33</u>	14	1	0	0	0
S.W. "	0	2	4	0	23	<u>30</u>	<u>19</u>	14	7	2	2	0
S.E. "	2	2	2	2	16	<u>29</u>	16	19	9	1	1	0
N.E. "	0	2	2	0	2	<u>31</u>	27	22	3	0	3	3

The underlined numbers indicate the deviations which have a maximum percentage for the quadrant.

Deviation over the Land.—For a land system the average deviation is between 3 and 4 points. The values for Pyrton Hill and Southport, given by J. S. Dines in the Fourth Report on Wind

¹ *Manual of Meteorology*, Part IV, p. 22.

Structure, are 32° and 44° respectively. If the different quadrants be considered they give the following deviations.

TABLE XVI

RELATION OF SURFACE WIND TO GEOSTROPHIC WIND AT PYRTON HILL AND SOUTHPORT

Geostrophic Wind Direction	N.W.	S.W.	S.E.	N.E.
Deviation in degrees (Pyrtton Hill)	39°	38°	32°	19°
" " " (Southport)	43°	56°	46°	31°

The deviation therefore varies considerably from one station to another, and much depends on the situation and exposure of the station.

Deviation from the Geostrophic Wind in Velocity.—Not only does the observed wind differ in direction from the gradient or geostrophic wind, but it also differs in velocity, and this difference varies throughout the day, by reason of the mixing of the various layers by convection. No simple rule can be given which will enable one to determine accurately the surface wind at any given time from the gradient wind velocity. A rough guide is that for fresh or strong winds the wind over the surface of the land is $\frac{1}{3}$ the gradient wind and over the sea $\frac{2}{3}$, so that the wind over the sea is double that over the land for the same pressure gradient. Here, however, arises the difficulty of the nature of the land, for if the surface be rough the diminution will be greater than in the case of flat open country. For the purposes of forecasting in both velocity and direction it thus becomes necessary for the forecaster to be familiar with the nature of the surface.

The effects of land and sea on wind velocity at the surface are very noticeable in the results obtained on the east coast of Great Britain, at Aberdeen, Spurn, and Yarmouth respectively. For winds coming directly from the sea the ratio of the velocities of the observed wind and of the geostrophic wind is much larger than for quadrants not so exposed. The following values, computed from the figures given by Shaw,¹ show that at all three stations the quadrants exposed to the sea give a much higher value than those enclosed by land. At Spurn Head, where the exposure to the sea is much better than at the other two stations, the ratio W/G is much higher, but yet the effect of the land to the west is marked by a diminution, particularly in the south-west quadrant.

¹ *Manual of Meteorology*, Part IV, p. 20.

TABLE XVII

RELATION OF SURFACE WIND TO GEOSTROPHIC WIND FOR ABERDEEN,
SPURN, AND YARMOUTH

W = surface wind and G = geostrophic wind, and W/G is expressed as a percentage. The winds are grouped into the four quadrants. The highest and lowest percentages for each station are underlined.

Quadrant.	N.W.	S.W.	S.E.	N.E.
W/G (Aberdeen) ...	45	33	42	<u>52</u>
„ (Spuru) ...	79	51	62	<u>74</u>
„ (Yarmouth) ...	<u>47</u>	36	55	<u>67</u>

The Aberdeen station is much opener to the north-west than to the south-west, for to the south-west lies the city, while to the north-west is the valley of the Don, and just as is to be expected, the ratio in the south-west quadrant is much smaller than in the north-west. Another point affecting all three stations is that winds coming from the south-west have to pass over a longer land path than winds coming from any other direction, and therefore we should expect the ratio for this quadrant to be smallest in every case. Observation shows that this is so, and the difference between this quadrant and the others is very marked, as the table shows.

Taylor's Relation. — Taylor in his investigations of eddy motion in the atmosphere has obtained a relation between the surface wind and the geostrophic wind in the form

$$W/G = \cos \alpha - \sin \alpha,$$

where α is the deviation in direction between the observed wind and the geostrophic wind. With suitable exposure and strong winds, the observed values and the calculated values of W/G show very good agreement, but if α is greater than 45° the ratio does not permit of being calculated in this way.

Though the observed wind at the surface differs both in direction and velocity from the gradient wind, yet at certain distances above the surface agreement is found both in direction and velocity. As a rule, the gradient velocity is reached before the gradient direction, the gradient velocity agreeing with the observed wind about 300 m. above the surface, while the gradient direction is not attained until the 800-metre level is reached. Above these heights the velocity, especially in westerly winds, tends to increase, and the direction changes more and more from that of the gradient, so that in the upper layers the air has a component of motion outwards from the centre of a depression.

Change of the Surface Winds during the Passage of a Depression.—When a depression is approaching an area, the surface wind changes gradually in direction, counter-clockwise in the Northern Hemisphere, and clockwise in the Southern, i.e. it begins to back. If the direction before the approach of the depression has been westerly, it changes through south-west to south, then to south-east, and perhaps to east, according to the position of the station with regard to the centre of the depression. As the depression advances and the pressure gradient increases, the wind velocity increases, and if the low-pressure centre passes to the north of the station, the wind gradually changes from south-east towards south and south-west, i.e. it veers as the trough approaches. When the trough passes it veers farther towards the west or north-west, following the alteration in the direction of the gradient wind. On the other hand, if the centre passes to the south of the station, the wind, instead of veering, continues to back through east to north-east, then to north, and finally to north-west.

Round a depression therefore the wind system is generally quite definite, and if the pressure distribution in the system be known, and the velocity and direction of motion of the centre, the various changes in velocity and direction which are likely to take place can be forecasted with great accuracy.

Distribution of Weather round a Depression.—As no two finger-prints are identical, so no two depressions have the same weather associated with them. Even when the pressure and the wind distributions at the surface of two depressions are almost identical, the weather associated with the two may be entirely different. There are several reasons for this. Depressions in the same latitude but in different parts of the world have different kinds of weather associated with them. In the same locality, the season of the year has a great influence on the type of weather. Again, at the same season of the year, the type of weather that may have been prevailing for a time plays a part in determining the weather likely to be experienced in any particular depression, i.e. the meteorological conditions at any time influence to a certain extent those that are coming. So to determine beforehand the weather likely to be associated with an on-coming depression, it is necessary to know more than the general surface conditions. The conditions in the upper air often give an excellent indication of the weather likely to be experienced, especially so far as pre-

precipitation is concerned. If the upper air is cold in front of the depression, the depression is almost invariably a "rainy" one: whereas if the upper air temperatures be relatively high, or show

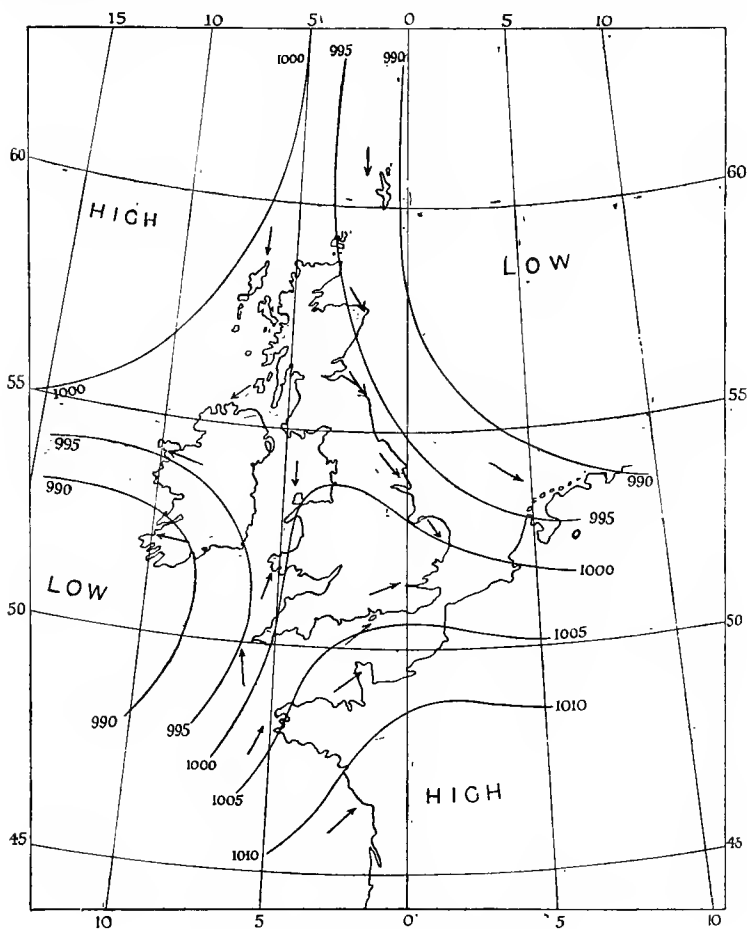

Fig. 71.—Depression approaching the British Isles

inversions, very little precipitation is likely to be associated with the system.

It is only possible therefore to give a general idea of the weather associated with a low-pressure system.

Suppose that fig. 71 represents a depression approaching the

western coasts of the British Isles. If the trajectories of the air entering the system be drawn, it is found that the air currents entering the various quadrants have different origins. The air entering the front right comes from the south or south-west; that entering the rear right from the west or north-west; the rear left is fed by currents mainly northerly. The trajectories do not appear to throw the same light on the origin of the air in the left front, for often on the edge of the depression in the north-east quadrant the winds are light, whereas the air in passing across the trough line shows a strong easterly current inclined towards the centre.

Fig. 72, which gives the trajectories for the depression 11th to 13th November, 1915, affords an idea of how the air enters a depression. The air entering the north-east quadrant appears to come down from the upper layers of the atmosphere, while the south and south-west currents on approaching the centre are lifted up over this descending current. This seems to indicate that the air does not rise within a depression in mean latitudes, uniformly in all quadrants.

The air entering on the right front is comparatively warm and contains much moisture, while that entering on the rear left is cold and contains little moisture, though the relative humidity in the two quadrants may not differ largely by reason of the difference of temperature. The result is that the front is muggy and close, causing an oppressive feeling; whereas in the rear the effect is bracing and exhilarating. This difference is largely due to the difference in absolute humidity in the two quadrants even more than to the difference in temperature.

Cloud Distribution.—Cirrus clouds often give the first indication of an approaching depression even before there is any alteration of the pressure or of the direction of the surface winds. Following the cirrus comes cirro-stratus, covering the whole sky with a veil in which appear halos and mock suns. The barometer now shows a downward tendency, and the wind backs to south or south-east. Nearer approach of the depression brings a sky covered with alto-stratus, through which the sun shines dimly, and which produces what is known as a "watery" or "weak" sky. It is at this stage that the air has a close muggy feeling. Very often within twelve hours after this appearance rain begins to fall, at first light, but gradually increasing in intensity as the storm advances, heavy

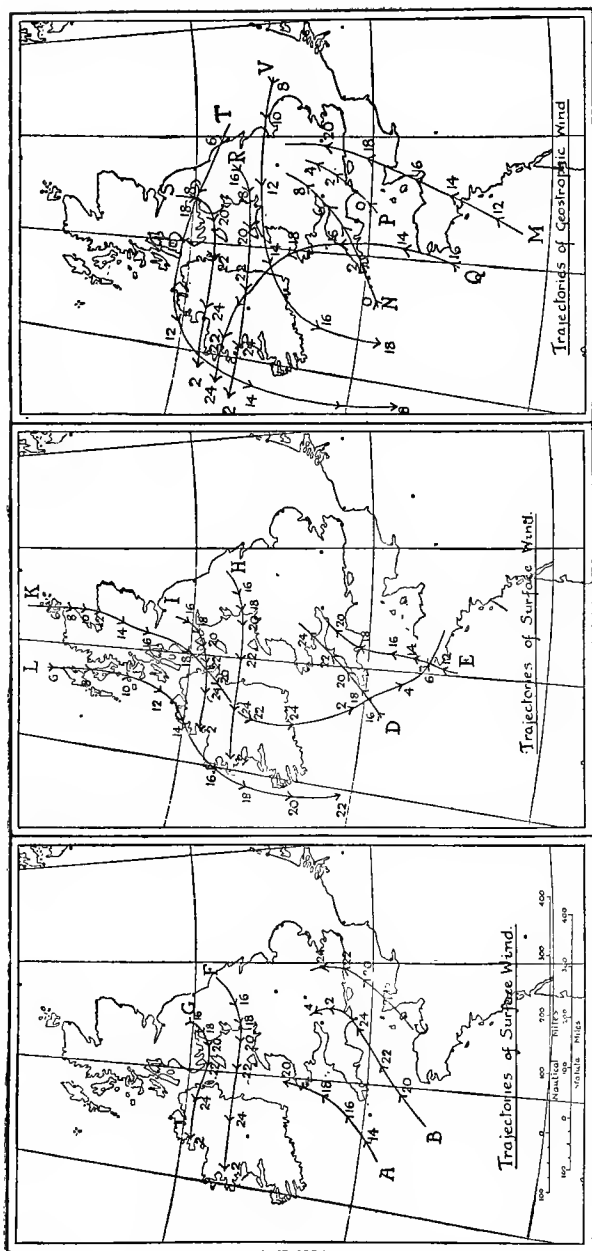

Fig. 72.—Air Trajectories in the Depression 11th to 18th November, 1915 (Geddes)

driving rain from low nimbus clouds falling in front of the trough. The passage of the trough is often attended with heavy squally rain, succeeding which the clouds begin to break, and though frequent squally showers occur at first, these become less frequent and less heavy, the nimbus clouds becoming less heavy, decreasing and breaking while the temperature falls. As the wind veers towards north-west or north the air clears, visibility often becomes excellent, and only some fracto-cumulus are seen to cross the sky. Such are the conditions in the front right and in the two rear portions.

The cirrus and cirro-stratus clouds appear over the whole front of the depression, and likewise the alto-stratus; but on approaching near the trough line in the front left the south-west current, rising over the north-east, is cooled down, and the sky becomes covered with heavy threatening clouds of the strato-cumulus type, which degrade into nimbus and give oftentimes heavy rain. This rain is often not so continuous as the rain in the right-hand quadrant, though the total amount is sometimes as great. It appears to be due to the dynamical cooling of the south-west current, and not to have its origin in the north-east current.

The front of a depression is therefore the portion in which the greatest amount of low cloud is found. In the right section the low-cloud sheet is nearly uniform, whereas in the left section the low cloud shows occasional breaks. The front is also the portion in which the greatest amount of precipitation falls. The trough is marked by heavy squally showers, often called "clearing showers", while over the whole of the rear are broken clouds and cold squally showers, the showers becoming less frequent and the clouds less heavy with increase in distance from the centre.

Fig. 73¹ shows the distribution of weather with reference to the centre of the depression of 11th to 13th November, 1915. Noticeable are the wide extension of the rainfall area in front of the depression, and the snow experienced in the north-east

¹Fig. 73 was prepared by marking on an outline map the pressure distribution at 18 h. on 12th November, when the centre of the disturbance was just off Scilly. This map was then superposed on each of the synoptic charts in turn with the marked centre over the position of the centre at the epoch of the map, and all weather observations shown on the chart traced upon it. The map was so oriented that the west-east line through the centre was parallel to the path. The international symbols ● and ✱ have been used to denote rain and snow respectively.

quadrant. Another striking feature is that in the north-east quadrant there are certain portions where neither rain nor snow is found, but instead portions of blue sky. This, however, seems to be peculiar to this storm, for similar diagrams prepared for

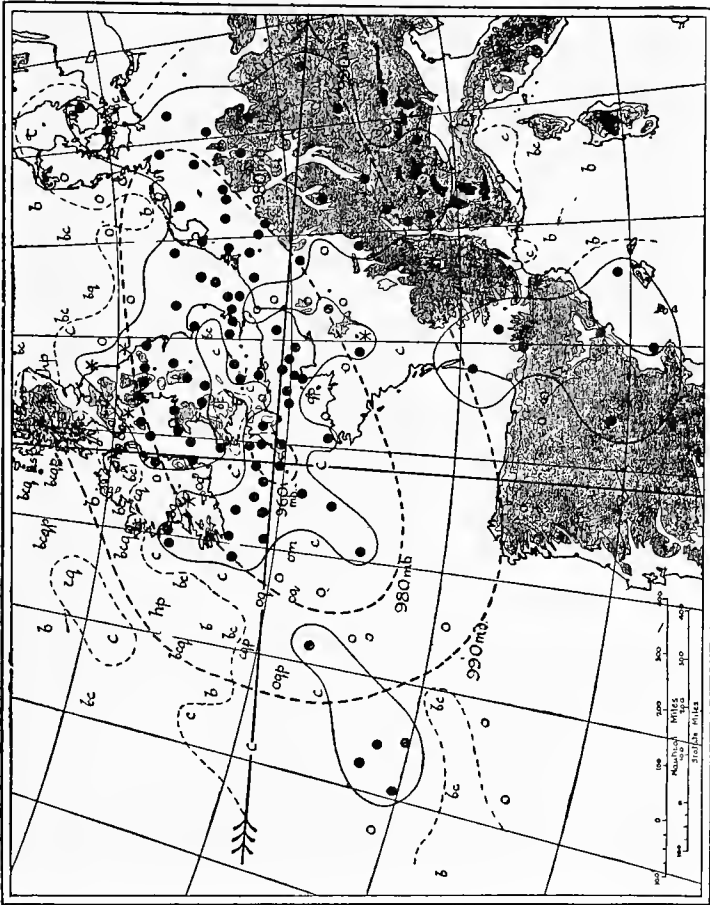

Fig. 73.—Distribution of Weather with reference to the Centre of the Depression 11th to 13th November, 1915 (Geddes)

the depressions examined by Shaw and Lempfert in the *Life History of Air Currents* do not show this peculiarity.

Movements of Depressions.—Not only must the meteorologist have a knowledge of the types of weather generally associated with depressions, but he must be familiar with the tracks

which depressions in mean latitudes generally take. By the aid of synoptic charts it has been made possible to follow depressions in their paths, and, as a result of investigations, it is found that for depressions approaching western Europe, the motion in a large majority of cases is from west to east with a tendency towards the north, especially on approaching the land. As the high-pressure belt over the Atlantic advances farther north in summer, depressions are found centred farther to the north, while in winter, as the high-pressure belt recedes, the disturbances move on a more southerly track. This represents only in very general terms the direction of motion and the principal paths of the Atlantic depressions affecting western Europe.

Rykatcheff's Diagrams.—Many efforts have been made to ascertain whether definite paths can be located, but hitherto all attempts have proved fruitless. Rykatcheff, formerly chief of the Russian Meteorological Service, prepared a chart showing the paths of all cyclones which passed over Europe in the month of October during the years 1872–87. Paths cross each other in all directions in this diagram, so that it is practically impossible to indicate a path which could be regarded as the mean path of the depressions. The majority of paths, however, are included in the regions between lat. 55° N. and 70° N., but within this region the number of north and south paths is almost as great as the number from west to east, though the number from east to west is very small. Very little can be gained, therefore, from a study of all the individual paths that depressions may take.

Van Bebber's Charts.—On the other hand one may group together all paths which bear a certain resemblance to one another, and in this way considerably reduce the numbers to be dealt with. This was the method adopted by van Bebber, and he has constructed a chart for Europe from data for the period 1876–80 showing the principal paths followed. This chart shows that the general direction is from west to east, with an inclination of two or three points towards the north. In the majority of cases depressions keep to the sea areas as long as possible, avoiding the land. Two main avenues of approach of depressions from the Atlantic are indicated, one to the north-west of the British Isles, which is the main one, and another which passes to the south of Ireland, across England and the North Sea, and thence to the Continent. Only in one direction is a land path evidently

preferred to a sea path, and that is by depressions forming near the entrance of the English Channel, which are shown to pass south-eastwards across France.

Köppen's Charts.—The tracks of depressions across the Atlantic, and even from the Rocky Mountains to the Urals, have

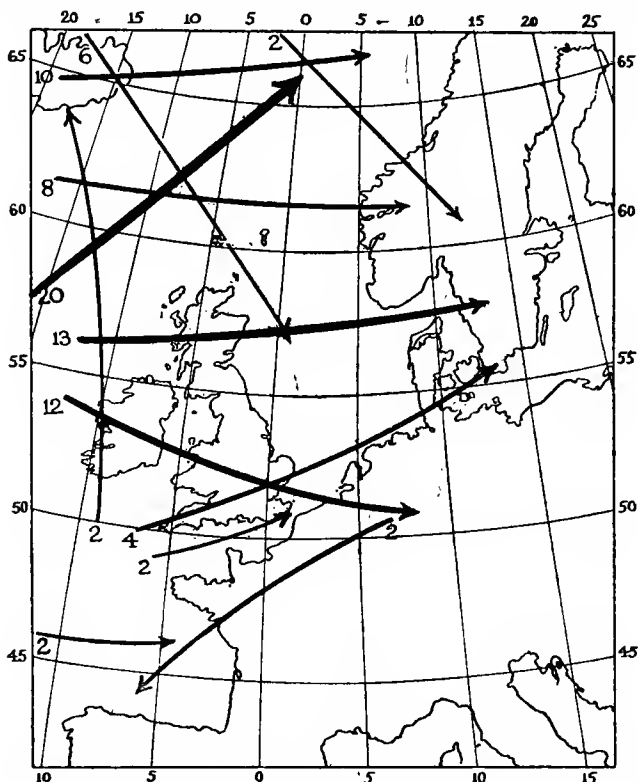

Fig. 74.—Movements of Depressions for year 1918. Figures indicate number of depressions with tracks approximating to those shown

been computed in a similar way by Köppen. The areas showing minimum pressure in that region have been found and the whole charted. This chart enables one to see that practically none of the American depressions ever cross to Europe, these on leaving the American coast taking a course mainly between north and north-east, and disappearing in the polar regions. The majority of depressions arriving on the western coasts of Europe have their origin

either on the Atlantic or on the edge of the permanent low, which stretches from the Pole to the neighbourhood of Iceland. Fig. 74 shows the tracks of depressions approaching Europe during 1918. It is representative, and indicates the principal avenues of approach. It will be observed that the path showing the highest frequency lies to the north-west of the British Isles.

Charts such as these give us certain general ideas of the paths followed, but they afford comparatively little help in determining in a particular case the path likely to be pursued by a depression. So far it has not been possible to formulate rules which will act as an infallible guide in this matter, and a forecaster, in dealing with the movements of depressions, must rely very much on his own experience and treat each case on its own merits.

Isallobars.—As the charting of the pressure distribution seemed to afford no definite clue to the motion of cyclones, Ekholm, of Stockholm, devised the method of plotting the pressure differences since the preceding observation in place of the actual pressures, thus obtaining charts of Isallobars instead of isobars. When successive charts of isallobars are drawn, the groups move very much after the same manner as the groups of isobars. Ekholm contends, however, that the movement of isallobaric groups is on the whole more regular than that of the isobaric groups. But a difficulty arises in the interpretation of what the exact physical meaning of these charts is. Evidently very different charts would be obtained if the charts were drawn for different intervals of time, and as Shaw suggests, the only real basis for the formation of these charts would be "*the rate of change taking place at the time of observation*".

Conditions Determining the Direction of Motion of a Particular Depression.—The forecaster, in determining the way a depression is to move, must have considerable information regarding both the conditions at the surface and those in the upper air.

SURFACE CONDITIONS.—It is essential that he should know the rate of fall of pressure in various directions, for this is even more important than the actual pressures, so far as direction of motion is concerned at least. Suppose that a depression is advancing from the Atlantic, and that observations from two stations on the west of Ireland, say Valencia and Blacksod, show that pressure is lower at Valencia than at Blacksod, but that the fall of pressure is increasing at Blacksod, i.e. that the rate of fall is

greater at the time of observation than it was at the previous time, while that at Valencia is decreasing. Then the forecaster may infer that the centre is likely to move in a north-easterly direction and not in an easterly. So, over districts where depressions are well developed and which border on the sea so that there are but small temperature differences at the surface, great attention must be paid to the direction of greatest fall of pressure, or the direction of steepest gradient, as in that direction low-pressure systems tend to move. If the wind at the surface in the front part of the depression be very strong from the south, it tends to destroy the gradient in that part, so that a depression which has moved for a time from west to east takes up a more north-easterly course, in this way following again the line of steepest gradient.

Over continental areas the pressure distribution in depressions is generally less well defined than over the ocean or on districts adjoining the ocean, such as the British Isles, and then much depends on the temperature differences. A depression then tends to move to the area which shows the biggest change in temperature from the time of the previous observation. This temperature change appears to precede the pressure change.

UPPER AIR CONDITIONS.—A close watch on the motion of cirrus clouds should always be maintained. These show the direction of motion of the currents in the upper air, and from these currents an idea of the temperature distribution at that level can be formed. Now a knowledge of the temperature distribution at all levels is very essential in determining how a depression is to move. From temperature observations, which should be taken in the upper air at least once in every twenty-four hours above stations suitably placed, the forecaster is enabled to see how the isotherms at the various heights are distributed and how they are changing. The number of observations of this kind hitherto made has been comparatively small, but from the information available, the conclusion seems to be that the depressions tend to move along the isotherms, or perhaps more accurately along the dividing line between a mass of cold air and a mass of warm air.

It is very evident how essential it is to be able to determine accurately how a depression will move. On the right of the path the winds are from the south or south-west and the weather mild,

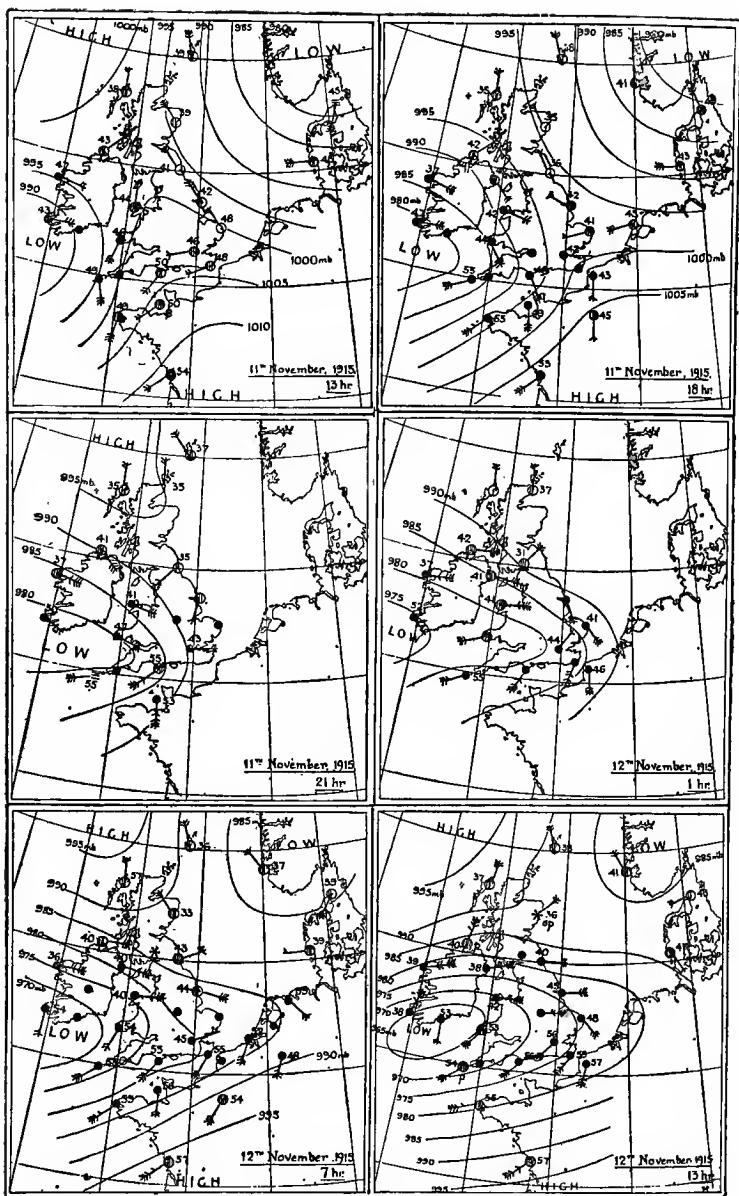

Fig. 75.—The Passage of the Depression 11th to 13th November, 1915, over the British Isles (Geddes)

even though much rain may be experienced. On the left the winds in front are north or north-east and have a cold origin. The moist warm south-west current has been raised up and cooled by this north-east current, so that the precipitation is much colder than on the right side, and in winter very often consists of sleet or snow,

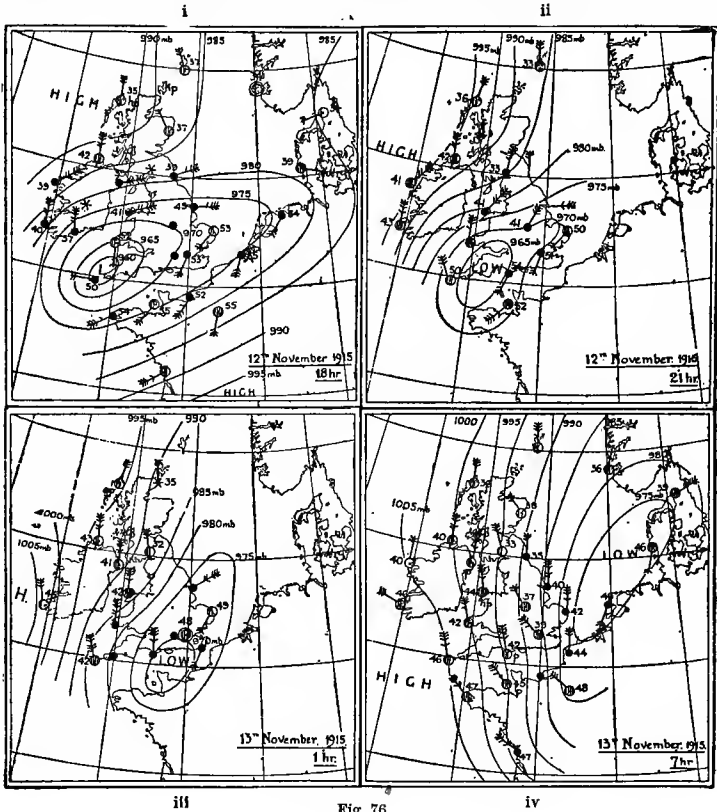

Fig. 76

while that on the right side consists of rain. The direction of the path with reference to any station may therefore mean for that station the difference between a storm of rain and sleet from the south-west and a snowstorm from the north-east.

The passage of the depression of 11th to 13th November, 1915, across the British Isles is set forth in figs. 75 and 76. The path of the centre lies over the sea almost throughout the whole course,

exemplifying the tendency of the centre to move over the sea rather than over the land.

The differences in temperature between the two sides of the depression are very well marked, showing the difference in origin of the currents. In the north the temperature ranges from 35° F. to 38° F., in the south from 49° F. to 55° F., a difference of about 15° F. When the cold northerly current became established behind the depression the temperature over the whole country fell to 40° F. approximately, the difference between north and south being now only about 4° F.

Velocity of Translation of the Centre of a Depression.—

As there are no definite paths along which the centres of depressions pass, so there are no definite velocities with which these centres move. On the average, however, depressions move more quickly in winter than in summer, and intense depressions move more quickly than shallow depressions. Also in different parts of the world depressions move with different velocities. The following values have been given for America, Japan, Russia, North Atlantic, and western Europe, 26 miles per hour, 24 miles per hour, 21 miles per hour, 18 miles per hour, and 16 miles per hour respectively, showing that in the United States depressions move more rapidly than in any other country in the Northern Hemisphere. These are average velocities for the year. The velocities in winter are almost double those of summer.

Though the forecaster must have a knowledge of these average velocities, yet he is compelled to examine each depression on its own merits. For no depression moves with uniform velocity, and therefore averages will not assist him much in any particular case. It is only through long and careful study of weather-charts from day to day that a forecaster is enabled to determine what the behaviour of any particular depression will be.

ANTICYCLONES

The term anticyclone was first coined by Sir Francis Galton,¹ and it was intended to convey the idea not only of an area of high pressure as compared with an area of low, but that the meteorological conditions in the two systems were very much opposed to each other.

¹ *Loc. cit.*

Extent of an Anticyclone.—Anticyclones may be divided into three groups. First, when the temperature over a large tract of land, such as Siberia, falls very low, then an area of high pressure forms, which remains almost stationary over the country throughout the cold period, and disappears during the warm period. This anticyclone occasionally spreads over Europe during the winter, causing severe frosts. Such was the case during January, 1917. Anticyclones of this type have been already considered in Chapter V. Second, during the winter, and to a less extent during the summer, areas of high pressure form over western Europe, and remain almost stationary for days, or even weeks, on end. These average in diameter over 2000 miles. They form slowly, have no apparent direct connection with depressions, and decrease gradually, just as they formed. Third, between two depressions there exists an area of relatively high pressure. Sometimes this area is small, in which case it is called a wedge of high pressure, but at other times it reaches large dimensions, with a diameter in the neighbourhood of 2000 miles. This type is more common in America than in Europe. Often with a depression near the Atlantic and another near the Pacific, there is a large area of high pressure between the two. High-pressure areas of the first type exist over land areas only in the cold period. The other two types are, on the average, larger in winter than in summer.

Pressure in an Anticyclone.—The pressure at the centre of an anticyclone is generally in the neighbourhood of 1035 mb., but it occasionally rises above 1040 mb. in a large high-pressure area. The decrease towards the boundary is much less regular than in a cyclone, so that the isobars often form very irregular curves round the centre. This makes it often very difficult to measure the pressure gradient. In almost all cases, however, the pressure gradient is small on account of the great extent of the anticyclone.

Wind in an Anticyclone.—The position of highest pressure is at the centre, so that the direction of the wind within this system is opposite to that in a depression, i.e. it is clockwise in the Northern Hemisphere and counter-clockwise in the Southern. Also the air moves outwards from the centre, the deviation from the direction of the isobars being very irregular, due largely to the feebleness of the winds in the system. This deviation is greatest in the south-west quadrant. As the pressure gradient is small, only light or moderate winds are to be expected in the system, especially in the

neighbourhood of the centre. Further, the curvature in an anticyclone is in the opposite direction to that in a cyclone, so that the expression for the gradient wind in this system becomes

$$\frac{\gamma}{D} = 2 \omega V \sin \phi - \frac{V^2}{R} \cot \rho,$$

indicating that the geostrophic wind and the cyclostrophic wind are now in opposition. Gold¹ has shown that if this equation be solved as a quadratic for V corresponding to a given value of γ , that the roots become imaginary if

$$\omega^2 \sin^2 \phi D - \gamma \frac{\cot \rho}{R} \text{ is negative, or } \frac{1}{r} > \sqrt{\omega^4 \sin^4 \phi \frac{D^2}{\gamma^2} + \frac{1}{R^2}}$$

where r is the radius of curvature of the path. The curvature, therefore, cannot exceed a certain limiting value. Near the centre of the anticyclone, where the curvature is relatively great, the wind velocity cannot then exceed the limiting value $\frac{R \omega \sin \phi}{\cot \rho}$. Also in this region $\cot \rho = \frac{R}{r}$ approximately, whereby $V = \omega \sin \phi r$ to a first approximation. Light airs or calms are therefore frequent near the centre of an anticyclone, especially at night.

Weather and Cloud in an Anticyclone.—The common belief is that the weather associated with anticyclones is always fine, and the sky cloudless. This, however, is not always the case. In anticyclones of the second type the sky often remains overcast for days on end, a comparatively thin, low layer of stratus forming over the whole sky. Above this layer the sky is clear, and the mountains and hill-tops are in bright sunshine. This layer of cloud forms about 3000 ft. above the earth, and temperature observation in the upper layers shows in such cases an inversion of temperature about that level. Though this sheet of cloud forms, practically no rain is ever experienced in such an anticyclone. Should this cloud layer disappear before the anticyclone breaks up, then the sky remains thereafter clear and the weather fine until the high pressure begins to give way. In an anticyclone between two depressions the behaviour is different. The front or eastern side still contains cloud of the fracto-cumulus type which was associated with the depression just gone. Behind this and in front of the centre is found an area of fine weather and almost cloudless sky. On the western side of the centre, cirrus and cirro-stratus connected with

¹ M.O. Publication No. 190, 1908.

the oncoming depression begin to appear, and gradually increase in density as the edge is reached.

Rain in an anticyclone is very rare, though occasionally small showers of rain in summer, or slight snow showers in winter occur through rapid convection during the middle of the day. When the sky clears in a high-pressure system the weather in summer becomes warm, and in winter, cold, often with intense frost. This is due to radiation and insolation. The period of sunshine in summer is long, and the ground becomes heated, whereas the period of nocturnal radiation is short, and thus little cooling takes place. In winter the opposite takes place, and if an anticyclone remains stationary over an area for a long period, intense frosts are likely, as happened over north-east France in January–February, 1917. Radiation fogs are frequent in anticyclonic weather, especially in the autumn.

Over western Europe the eastern side of an anticyclone is colder than the western, and more so in winter, for on the eastern side the air passing over the earth's surface is cooled down in its path, apart from the fact that in its origin it is colder than the air feeding the western side. On the western side the air, warmer than that on the eastern side, on reaching the earth's surface is less cooled, because part of its surface-path is over the sea and part over land surface where the temperature is not so low as on the eastern and northern sides.

In the region between a cyclone and anticyclone the weather is often capricious, especially when the cyclone is on the polar side of the anticyclone. Under the latter conditions, rain in summer, snow and sleet in winter are met with in this region equally with fine weather. This variable type of weather is largely accounted for by the difference in temperature of the air currents, and while an area is under the influence of such a distribution of pressure, fair weather for any long period cannot be expected.

Direction and Velocity of Translation of an Anticyclone.—Anticyclones of the first type advance and recede, having therefore no real direction and velocity. The second type moves very slowly, remaining almost stationary for days, but the general tendency is to move from west to east. An anticyclone between two lows, which is really after the nature of a wedge, moves with approximately the same velocity as that of the lows with which it is associated, and the direction of the path is nearly the same. In the United States, where this type of anticyclone is more frequent

than in Europe, the mean paths of anticyclones are closely related to those of depressions, and the mean velocity of translation is reduced only slightly.

In Europe the paths followed are much more erratic than those of cyclones, as the type of anticyclone between two depressions is not so frequent. For the same reason the average velocity is much smaller than that of cyclones.

DIFFERENT GROUPINGS OF ISOBARS

In dealing with depressions we have considered the isobars as forming almost regular closed curves round a central point. This regular distribution of pressure is seldom found, however, even in well-developed cyclones, and instead we find the isobars arranged in various formations. These formations or distributions of pressure have been arranged in classes largely on the basis of the weather associated with them.

A Wedge.—Between two depressions there may be an area of high pressure which is very limited. As the first depression moves away pressure rises quickly behind it for a time, then ceases, and after a short time begins to fall again, thus indicating the approach of a new depression. This region of high pressure, which is small compared with an average anticyclone, is known as a "wedge" or "ridge" of high pressure. It is almost invariably accompanied by good visibility and a very fine interval, the duration of which depends on the size of the wedge and the velocity of translation of the system.

Straight Isobars.—Round a centre of high pressure the curvature of the isobars is in the opposite sense from that round a low. If the depressions are moving along the edge of an anticyclone which is almost stationary, there is a region between the two systems where the isobars are almost straight. This distribution is known as a region of straight isobars. The weather associated with such a distribution, as already stated, is very variable.

The Col.—If two highs and two lows be grouped alternately on a chart, then the saddle-shaped area enclosed by them is known as a Col. The weather associated with such a pressure distribution is very uncertain, and in summer-time it is often the seat of thunderstorms.

Sinuosity and Secondary Depressions.—If the irregularities in the isobars round a low-pressure centre cause only slight altera-

tions in the direction of the wind, then these distortions are called *Sinuosities* in the *Isobars*. Very often rain is associated with these sinuosities, so that a forecaster in examining his chart must be careful to note any hint that the wind direction would give him as to the likelihood of such being present, in an otherwise apparently straightforward chart. Should the distortion become great a separate low centre often forms, and such a centre is called a *Secondary Depression*. Often violent winds and heavy rain are associated with these secondaries, and also thunderstorms, especially in the summer-time. The velocity of translation of the centre is generally much greater than that of the original depression, and in this way they sweep counter-clockwise round the primary depression, so that the centre, from being behind that of the primary, may pass to a position in front of it. Sometimes the secondary increases, deepening and extending as it moves forward, until finally it coalesces with the primary, and the two forming at first a "dumb-bell" depression revolving counter-clockwise, ultimately form one depression, and as such pass from off the area of the chart.

The V-Shaped Depression.—Midway between the sinuosity and the secondary depression, with its detached centre, comes the *V-shaped depression*. It is so called on account of the shape of the *isobars*, which present a *V-shaped* appearance easily recognizable. As the *V* passes over an area, there is a sudden change of wind direction and of temperature. A moderately warm south-west current—for the *V*, like the secondary, is practically always on the equatorial side of a depression—is suddenly replaced by a cold north-west one. This sudden change of wind-direction often takes place in a squall, with which there is associated rain or even hail and sometimes thunder. The wedge is sometimes regarded as an inverted *V* so far as the pressure distribution is concerned, and in the matter of weather it might with equal reason be regarded as the direct opposite.

The arrangement of the *isobars* in the various groupings is set out in fig. 77.

The Surge.—Sometimes a general diminution of pressure takes place over a whole chart in a short time. The usual movements of cyclone and anticyclone take place, but at the same time there is found a general lowering of pressure as though a part of the atmosphere had been removed from over the whole area. Such an effect is known as a *Surge*.

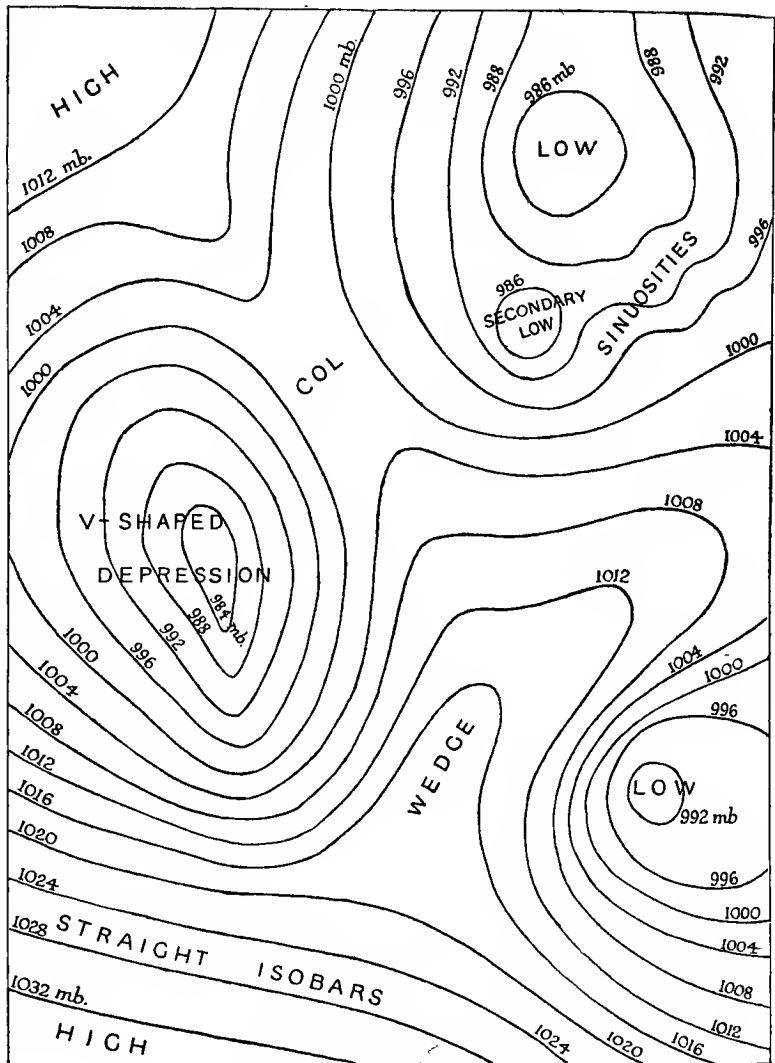

Fig. 77.—Various Groupings of Isobars

WINDS ASSOCIATED WITH CYCLONES AND ANTICYCLONES

Föhn Wind, Chinook Wind.—When a depression is passing over central Europe from west to east, and a high is situated over northern Italy, the air from the high is drawn across the Alps into the low-pressure system, descending on the northern side

as a warm dry air current. For the air by being forced up the southern slopes is cooled down by expansion and brought below the point of condensation, so that quantities of moisture are precipitated on the windward side of the mountains. The air therefore obtains a considerable potential temperature, and when it begins to descend on the northern side, it rises above its original temperature, for on the south or windward side of the Alps the fall of temperature was about 1° A. for every 200 m., whereas the rise on the northern side is about 1° A. for every 103 m. The air on reaching the plains becomes cooled again by contact with the cold earth, so that it is only in close proximity to the mountain range that the full effect is felt. There the rise of temperature may be as much as 12° A., causing thereby large quantities of snow to disappear by evaporation. The process is not so simple as it at first appears, for the cold air in the valleys must first be got rid of before the warm air can take its place. Shaw is of the opinion that the cold air in the valley is first excavated by the eddy motion in the current caused by the ridge. This results in a current of air on the lee side of the mountain range extending in thickness from above the ridge to the bottom of the valleys in which the entropy is everywhere equal. As the air passes over the cold surface the layers nearest the ground become cooled, and the distribution is thereby rendered more stable.

Exactly the same effect is found on the eastern side of the Rocky Mountains. There the warm dry winds are called Chinook Winds. And so practically everywhere that geographical conditions similar to the above exist, winds of the föhn type are experienced, e.g. the Santa Anas of California and the hot winds of the Plain States of America. To a slight extent the effect is felt on the eastern side of the mountains in the United Kingdom.

Cold Winds: THE BORA.—As an example of a current of air flowing from a high towards a low the Bora of the Adriatic will serve. It is so named because it is a cold northerly wind. When pressure is high over southern Austria and low over the Adriatic a flow of air takes place towards the sea. This occurs only in winter, and at that time the land is very cold compared with the sea. The air in its passage over the land is being continually cooled down, so that though a slight warming takes place on account of the descent of the air, it is not sufficient to raise the temperature of the air to that of the sea, and so the wind arrives as a

cold dry wind. On the western shores of the Adriatic occurs the "tramontana", a similar cold northerly wind. In Malta the "gregale" is due to the same cause, and the "williwaus" of Tierra del Fuego is apparently of the same origin. On the eastern side of the Black Sea similar winds are encountered.

THE MISTRAL.—When pressure is high over northern and western France and low over the Gulf of Lyons, then there is a flow of air from the north-west towards the low centre. To the north the country is comparatively open, but the air current on approaching the south finds itself constricted on both sides, on the left by the Alps, and on the right by the Cevennes. In this way it is confined almost entirely to the valley of the Rhone. The velocity is thereby increased considerably, and as the wind is northerly and the air has been moving over the land for a considerable distance, it arrives at the Mediterranean as a violent cold northerly wind.

Similar winds are the cold north winds in the United States.

Other cold winds are the "buran" or "purga", which occurs over Russia and Central Asia, and flows from the north-east; the "pamperos", a cold south-west wind of Brazil and the Argentine; and the southerly "buster" of New Zealand.

Warm Winds: THE SIROCCO.—This is due to a low over the Mediterranean and a high over northern Africa. Under these conditions a strong wind from the south or south-west blows off the African coasts and arrives over Sicily, southern Italy, and Greece as a warm moist southerly wind called the Sirocco. The moisture in the air current arises from evaporation as the air sweeps over the Mediterranean. Often this wind is found to carry with it fine dust from the Sahara. On the African coast it is warm and dry, and at that point it contains but little moisture, coming as it does from the desert. Starting from there with a high temperature, the air has this temperature further increased by its descent from the inland plateaux to the coastal regions. Similar winds are the "solano", a warm south-east wind on the eastern coast of Spain; the "leveche", a hot, dry south-west wind also occurring in Spain; and the "leste", a hot parching wind, which occurs in Madeira and northern Africa.

On the other sides of the Sahara are the "khamsin" in Egypt and the "harmattan" in Senegal. The former blows from between south and south-east, and lasts from twenty to fifty days in the

course of the year; the latter is a hot, dusty east wind bringing much sand with it. It is most common during the months of December, January, and February.

The wind in Palestine, Arabia, and Syria corresponding to these winds is the "simoom", which is hot, dry, and sand-laden. The name signifies "poison wind", but there are no poisonous gases associated with it.

In the Southern Hemisphere the hot, dry, northerly winds blowing over southern Australia from the central deserts are known as the "brickfielders"; while the "zonda" of the Argentine is a hot northerly sirocco.

All these winds are associated with the passage of highs and lows, while certain of their characteristics are due to the nature of the surrounding regions.

The Origin of Cyclones and Anticyclones of Mean Latitudes: THERMAL THEORY.—When a mass of air is heated it expands, and volume for volume becomes lighter, so that it is forced up by colder denser masses of surrounding air. When a circulation of this type is once started it tends to reduce the pressure over the heated area. All depressions were therefore at one time regarded as being due to the heating of air near the surface. This appears to be the origin of shallow thunderstorm depressions which occur in summer during the hot part of the day, and tropical cyclones also are probably in great part due to this cause. But when the theory is applied to depressions of mean latitudes, it is found to be inconsistent with the observed facts. If the thermal theory were correct, then depressions should be more frequent during summer than during winter. The opposite is the case, for the number of depressions crossing Europe during the winter is much greater than that during the summer. Also the temperatures of the lower layers of the depressions should be higher than those at the same level in the anticyclone, even after allowance is made for the difference in pressure. But this is contrary to observation, for up to about 9 Km. above the surface of the earth temperature is lower in the cyclone than in the anticyclone. The thermal theory, as first propounded, cannot therefore be accepted as an explanation of the origin of cyclones and anticyclones of mean latitudes.

EDDY THEORY.—Up to the height of the cirrus clouds and also within the stratosphere, the general circulation of the atmosphere in mean latitudes is from west to east, the wind veering

in direction with increase in height. Now as the different layers of the atmosphere have different velocities, it is conceivable that eddies may be started in the upper layers which would make themselves felt at the surface in a reduction of pressure. In winter the circulation of the atmosphere is more vigorous than in summer, and so this theory would account for the greater number of depressions in winter. The eddies would start with equal likelihood in either direction, but owing to the earth's rotation, clockwise eddies would disappear in the Northern Hemisphere and counter-clockwise eddies in the Southern. This theory, however, does not explain why the temperature difference changes between the cyclone and the anticyclone in passing from the troposphere to the stratosphere.

COUNTER-CURRENT THEORY.—According to the counter-current theory of origin, depressions arise from the juxtaposition of two air currents of very different temperature. On account of the unequal effect of solar radiation on land and on water, the general distribution of pressure is not regular, and the upper air currents are in consequence not steady but become broken up, so that a mass of cold air coming from the direction of the pole finds itself in juxtaposition to a mass of warmer air coming from lower latitudes. The result according to the theory is that a whirl is set up in the atmosphere, counter-clockwise in the Northern Hemisphere and clockwise in the Southern, thus causing a lowering of pressure within the whirl and so the production of a low. The height at which the conflicting masses are regarded as coming in contact is from $1\frac{1}{2}$ to 2 Km. above the surface. Below this the air spirals in towards the centre, and above this height the two currents run more or less side by side, drawing off the air rising near the centre of the whirl.

This theory, however, does not appear to be in agreement with wind observations as determined by pilot balloon ascents, nor does it afford an explanation of the temperature differences between cyclone and anticyclone within the troposphere and the stratosphere respectively.

Origin due to the Stratosphere.—In the troposphere practically three-fourths of the atmosphere is found, yet the disturbances found at the surface of the earth appear to have their origin in the stratosphere, or, in other words, the stratosphere with its quarter of the atmosphere dominates the troposphere.

Up to the boundary line between the two, but within the troposphere, the pressure gradient *and* the temperature gradient are in the *same* sense. Above the bounding surface and within the stratosphere the temperature gradient is in the *opposite* sense to the pressure gradient. Within the troposphere, therefore, the cyclone is colder than the anticyclone, and vice versa within the stratosphere. There comes therefore a critical layer at the bounding surface, i.e. at a height of about 9 Km. above the surface. Shaw has shown¹ that at this height the air is moving horizontally, i.e. that no vertical component exists, and so no air is passing from the troposphere to the stratosphere. Also at this height the wind velocity is a maximum, and the direction is generally from west to east, though not invariably so. Within the stratosphere the wind velocity decreases, and as the temperature gradient is in the opposite sense from that below the critical layer, at great heights an easterly current may result.

Dines has calculated the standard deviations of pressure from the normal for all levels up to 9 Km., obtaining the following results:—

Height in kilometres,	8	7	6	5	4	3	2	1	0
Standard deviation in millibars,	11.0	11.4	11.5	11.5	10.9	10.7	10.5	10.5	10.8

Thus at all levels within the troposphere pressure is subject to changes of the same order of magnitude, although the normal values at the top and bottom are very different. On the other hand, the correlation coefficient between the deviations of pressure at the surface and the mean temperature of the 9 Km. column is small, so that the mean temperature of this air column has very little to do with the distribution of pressure at the earth's surface.

But a very close relation is found to exist between the pressure at 9 Km. and that at the surface. If the pressure in this critical layer is low, the pressure at the surface is low; if it is high, the pressure at the surface is high. So the distribution of pressure in the upper layers of which that at 9 Km. is typical, is transmitted to the surface, and defines the distribution of pressure there. In other words the stratosphere dominates the troposphere, and the origin of cyclones and anticyclones is to be found not in the lower layers of the atmosphere but in the upper layers.

¹ *Proceedings Royal Society, Edinburgh*, Vol. XXXIV, 1914.

By observation it has been found that the pressure at 20 Km. above the surface is practically constant (the value being about 55 mb.) all over the globe and at all seasons. This pressure distribution is determined by the mean temperature of the air column from the surface to 20 Km., so that this mean temperature must be the same everywhere and at all seasons. There is a difference in the mean temperature of the troposphere from summer to winter in mean latitudes, and therefore there must be a difference in the stratosphere in the opposite sense. Circulation is thereby likely to be more vigorous in the stratosphere in winter than in summer. so that the number of depressions in these latitudes will be greater in winter than in summer.

The Energy in a Depression.—In every depression there is present a tremendous amount of kinetic energy, and as a depression may persist for days and sometimes even for a week, on end, it must draw its energy from some source. In the thermal theory of origin, the energy was looked on as being supplied by the heat liberated through condensation. Though this source may contribute a certain amount of energy to the system, it is not the prime source, for often depressions are experienced in which there is a tremendous amount of energy with but very little precipitation. On the other hand depressions in which there is considerable precipitation are sometimes comparatively inactive.

Another source of energy is found in the general circulation of the atmosphere, and in the eddy theory this source was regarded as the main source.

The mean temperature of the atmosphere from the surface to the 20 Km. level is constant in all places and at all seasons. But though the mean temperature is constant the distribution of temperature from layer to layer is by no means constant, and in the adjustment of these differences in temperature is found a source of energy for the maintenance of the depression.

B.—TROPICAL CYCLONES

Within the tropics pressure variation is largely confined to the diurnal and annual variations, but certain well-defined storms occur, and it was to these storms that the name cyclone was first applied. The whirling nature of these storms was recognized as early as 1650 by Varenus in his *Geographica Generalis*. Dampier has

given his experiences of them in the China Sea in 1687. It was not, however, until the beginning of the nineteenth century that these storms were studied in detail. Redfield in America, Reid in England, Piddington in India, all contributed to our information regarding them, and were able through their investigations to formulate the laws of motion of these storms, and to suggest rules which sailors should observe in order to avoid the extreme violence of these hurricanes, should they find themselves at any time in their neighbourhood. These rules as given by Piddington in his *Horn Book for Mariners* were: first, "to avoid running before the wind, particularly when the centre of the cyclone is to the westward as this would bring the vessel towards the centre and across the track of the coming cyclone; and second, to direct the vessel so as to avoid as far as possible the 'dangerous half' of the cyclone." Since the days of these pioneers many investigators have added to our knowledge, among whom may be mentioned Dove, Espy, Mel-drum, and Ferrel.

Regions of Tropical Cyclones.—These storms are chiefly confined to five definite regions on the earth's surface, three in the Northern Hemisphere and two in the Southern. These are (1) the West Indies, the Gulf of Mexico and the coasts of Florida, where they are called hurricanes; (2) the seas on both sides of India, i.e. the Arabian Sea and the Bay of Bengal; (3) the China Sea and the coasts of Japan, where they are known as typhoons, and over the Philippine Islands, where they are called baguios; (4) the Indian Ocean to the east of Madagascar and Mauritius; (5) the Pacific Ocean to the east of Australia and Samoa. All these regions, it will be observed, are on the western side of oceans, and no region of tropical cyclones is found on the eastern side of an ocean. All the paths originate over the sea, and if a cyclone passes on to the land, the path over land is short, for the storm soon loses its characteristic violence, behaving thereafter like a depression of mean latitudes, or else disappearing altogether.

Some Features Peculiar to Tropical Cyclones.—In many ways tropical cyclones and depressions of mean latitudes are similar, but there are also marked differences between the two. The direction of the wind in both systems is the same, i.e. counter-clockwise in the Northern Hemisphere and clockwise in the Southern, but the intensity of the wind is very much greater in the tropical than in the extratropical. This is accounted for

largely by the difference in pressure gradient. The average pressure at the centre of a cyclone is 960 mb. and on the periphery 1020 mb. Now the diameter of these storms ranges from 300 to 600 miles, giving a mean value of about 450 miles, whereas the extratropical cyclones have a mean diameter of 1000 miles. Pressures lower than 960 mb. are met with in depressions of mean latitudes, but such low pressures are by no means common, and a depression in which the pressure descends to this value is accompanied by violent gales, as in that of 11th to 13th November, 1915, where the value fell below 960 mb. So with the same difference in pressure over half the distance the gradient is doubled, and this in comparison with the most intense type of depression, and the wind is increased accordingly. Another peculiarity is found near the centre of low pressure. The transition period when the wind changes from one direction to another is much more marked in the tropical cyclone than in the extratropical. In the central area of about 25 miles diameter of the tropical cyclone there is little wind. The violent winds of the cyclone give place at first to moderate winds, and then for a space of about 5 miles diameter a dead calm takes place. Beyond this the wind again becomes moderate from the opposite direction, and then outside the 12 miles radius it increases again to a hurricane as suddenly as it fell off.

This central, comparatively calm area, is known as the "eye" of the cyclone on account of the peculiar weather conditions experienced in it. There the torrential rain associated with the cyclone ceases, the clouds become much thinner, sometimes even breaking and showing patches of blue sky, but this is only on rare occasions. The temperature shows an increase and the humidity a decrease. After the passage of the cyclone normal conditions are re-established.

Passage of a Tropical Cyclone.—As in a depression of mean latitudes, so in a tropical cyclone the sky in front becomes covered with cirrus and cirro-stratus in which halos appear. The air becomes sultry and oppressive, the wind falls almost to a calm, and on the ocean a heavy swell rolls up. At this stage the barometer shows an upward tendency or remains steady at a period when the diurnal variation would cause a fall. In the second stage a breeze begins to spring up, the clouds become lower and heavier, and pressure begins to fall. In the third stage heavy rain-clouds, appearing first on the horizon, advance across the sky, the wind

increases rapidly, and the barometer falls quickly. As the rain-clouds pass overhead, the rain falls in torrents, the wind rises to a velocity of 100 miles per hour or more, the sea is lashed into foam, and this continues until the centre of the storm arrives. Here there is a short interval of calm, but following the passage of the centre, the wind increases to hurricane force again but from the opposite direction, the torrential rain is renewed, and the barometer rises as quickly as it fell. As the end of the storm approaches the rain-clouds break and disappear, leaving only cirrus, and the wind falls. Finally the sky clears, the wind drops, pressure becomes normal, and everything is as before the storm except for the swell on the ocean, and the destruction wrought.

Distribution of the Meteorological Elements round a Tropical Cyclone.—Round a tropical cyclone the distribution of the meteorological elements is much more regular than round a depression of mean latitudes. The isobars are only slightly oval, and the direction of motion of the centre is generally along the longer diameter. The wind blows in spirally towards the centre and subtends on the average an angle of about 30° with the direction of the gradient wind. The variation in wind velocity within the storm has already been considered in the previous paragraph.

The cloud distribution round the centre is very uniform. Cirrus and cirro-stratus are found on the outside. These give place to clouds of a lower type, cirro-cumulus and strato-cumulus, while nearer the centre come the heavy nimbus clouds from which fall torrential rains. In the eye of the storm these nimbus clouds thin off considerably and sometimes break, revealing patches of blue sky. This cloud distribution is in marked contrast to what is found in the extratropical cyclone where practically each quadrant shows its own peculiarities of cloud distribution.

Temperature and humidity are nearly identical in all four quadrants. The temperature falls from the outside towards the centre, slowly at first, then very rapidly as the rain begins to fall. It reaches a value at which it remains nearly constant during the period of rainfall, and then increases temporarily as the eye passes. On the opposite side of the centre, the temperature curve repeats itself, but in the opposite sense. The average temperature on the outside of the storm is 85° F. or 303° A., and during the period of rainfall 72° F. or 295° A. The curve showing the variation in relative humidity is almost the image of the temperature curve,

rising when the temperature falls and falling when the temperature rises.

Reason for the Central Eye.—As the air approaches the centre, the curvature of the path becomes greater, the velocity increases, and thus a condition is arrived at where the air no longer flows in towards the centre at the surface. Any air entering this region must therefore descend from the upper layers, and in its descent it is warmed. Evaporation takes place, and instead of a cloudy area in the centre one would expect diminution of cloud and occasionally clear patches of sky with a rise of temperature and fall in humidity, the amount of clearance depending on the intensity of the storm. This clear region should also be a calm region, as it is a region of descending air. Observation shows that all these conditions are fulfilled in the central eye.

Trajectories of Tropical Cyclones.—When the trajectories of these cyclones are drawn in any of the five localities where they are encountered, it is always found that they commence in the calm areas or doldrums near the equatorial borders of the trade winds, with the exception of those on the Bay of Bengal and the Arabian Sea. These present certain differences which shall be referred to later. The cyclone once commenced, the trajectory of its centre passes westwards and slowly polewards, due to the earth's rotation, until it crosses over the belt of the trade winds and enters the horse latitudes. Here it still passes polewards, arriving thereby in the current of the prevailing westerlies, and by reason of the earth's rotation and the prevailing winds it is turned eastwards, though it still possesses its poleward component. The curve is therefore parabolic in shape, with its vertex in the horse latitudes. Over the West Indies, in the Southern Indian and Pacific Oceans, the trajectories are on the whole regular, but in the China Sea, mainly on account of the land areas, they are much more irregular. The trajectories in the different areas are given in Chart XI.

In the neighbourhood of India the general circulation of the atmosphere is altered on account of the large mass of land to the north, and there we have for one half of the year the north-east monsoons and for the other half the south-west. At the times of change between the monsoons there are periods of calm, and the cyclones form at these times and owing to the rotation of the earth move northwards. There is no strong westerly or easterly

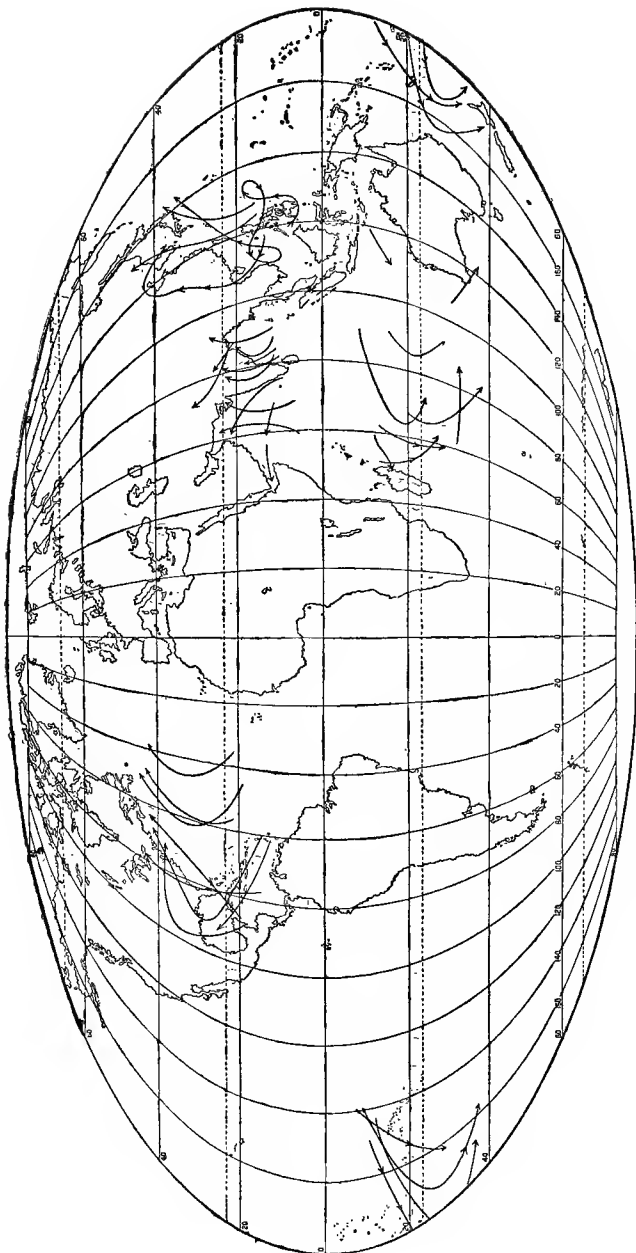

Chart XI.—Regions and Trajectories of Tropical Cyclones

component of the general wind circulation to carry them along, and so the average path is north or north-east.

These cyclones are all found to originate in calm areas, and their absence over the South Atlantic is therefore not a matter for surprise, for on that ocean the south-east trades cross the geographical equator, so that the doldrums do not there pass to the Southern Hemisphere.

The Velocity of Translation of Tropical Cyclones.—This velocity is, in the mean, less than that of depressions of mean latitudes. The average velocity also differs for different regions. In the West Indies the value is 15 miles per hour and in the China Sea 9 miles per hour, though the velocity varies considerably for individual cases, in this resembling extratropical cyclones. The velocity also varies during the passage of the cyclone; thus the cyclone which passed through the Bay of Bengal from 29th October to 1st November, 1876, began with a velocity of $7\frac{1}{2}$ miles per hour, but on reaching the land had a velocity of 20 miles per hour.

The Seasons of Tropical Cyclones.—The time of the year when these storms are most frequent is always at the end of the hot season. The time of the storms round India again forms an exception to this. In the other regions of the Northern Hemisphere about 80 per cent occur from July to October inclusive, and in the Southern Hemisphere an even greater percentage occurs between January and April inclusive. The percentage in December in the south is rather higher than in June in the north. In both hemispheres, therefore, the main period commences just after the time of the summer solstice, and when the thermal equator has ceased moving polewards. Around India there are two periods of maximum frequency corresponding with the times of change of the monsoons, a long period from April to June inclusive, and a short period during October and November. The behaviour on the two sides of India is rather different. In the Bay of Bengal 35 per cent of the storms occur in the first period and 43 per cent in the second, whereas in the Arabian Sea 63 per cent take place in the first, and 23 per cent in the second period. This difference between spring and autumn frequencies in the Arabian Sea arises from the fact that the air which has been brought to this area from the south-west in the autumn has passed over the hot, dry continent of north-east Africa, and in consequence contains very little moisture when it first reaches the sea. The

following table, according to Angot, gives the relative frequency in the different regions throughout the year.

TABLE XVIII

RELATIVE FREQUENCY OF TROPICAL CYCLONES

	Jan.	Feb.	Mar.	Apr.	May.	June	July	Aug.	Sept.	Oct.	Nov.	Dec.
1. Antilles ...	2	1	3	—	—	2	13	27	24	19	6	3
2. China Sea ...	1	—	—	2	4	6	19	22	26	11	6	3
3. { Bay of Bengal ...	2	—	1	8	18	9	3	3	5	27	16	8
{ Arabian Sea ...	3	—	1	15	20	28	—	2	5	7	16	3
4. Southern Indian } Ocean ... }	24	25	18	12	4	1	—	—	—	1	5	10
5. Southern Pacific } Ocean ... }	29	19	28	5	4	—	—	—	1	1	4	12

Origin of Tropical Cyclones.—The times and the places of their occurrence, together with their general behaviour after development, seem to point to a thermal origin for tropical cyclones. If they are of thermal origin certain conditions must be fulfilled, though it does not necessarily follow that the origin is entirely thermal should these conditions be fulfilled. Let us consider first the conditions necessary for thermal origin.

(1) The regions in which they form must be regions of comparative calm. If this were not so, then the air would be continually mixing in a horizontal direction, and vertical convection on a large extent would not be possible. As the air near the surface in these calm regions becomes heated, then it expands and forces up the air above it, causing the pressure on its two flanks to increase, so that the air near the surface flows in from both sides. This in its turn is warmed and ascends, and a convection system is thereby started. Now if the air flowed radially in towards the centre, there would be no cyclonic motion. This would be the case if the convection were taking place only on the Equator. But the belt of equatorial calms is not centred on the geographical equator, and further it changes its position with the seasons. The hurricanes of the West Indies have their origin on the equatorial side of the north-east trade winds in lat. 10° N. of the Equator. Now the air from the north-east entering an area where rapid convection is taking place will not move straight towards the centre, but will have its course bent towards the right on account of the earth's rotation. Similarly air coming from the Southern Hemisphere on passing to the Northern will

have its course changed towards the right, though the deviation will not be so great as that of the northern current, as the deviation depends on the latitude. This explains why the cyclone, once formed, tends to move away from the Equator. These two currents are then moving counter to one another over a region where pressure is diminishing on account of rapid convection, and they will therefore tend to accentuate the diminution of pressure.

The regions on the earth's surface where the formation of tropical cyclones is possible on the thermal theory are therefore to be looked for in the doldrums near the borders of the trade winds, and in the regions of the monsoons. An examination of Chart XI (p. 237) shows that these are the only regions they do occur in, and that they do not occur in the South Atlantic because the belt of equatorial calms does not invade that region.

Calm areas are found in the horse latitudes as well as at the Equator, but the former are centres of high pressure belts, and so there is no general ascending current as there is in the region of the doldrums. Hence cyclones of the tropical type are not likely to originate in these regions.

(2) A source of energy must be accounted for. The air in the calm region of the doldrums is moisture-laden, and when the masses of air ascend through pressure from the denser air on the flanks, expansion, cooling, and condensation take place. An immense amount of heat is thereby liberated which helps to maintain circular motion. If no condensation took place, then the energy obtained from the heated surface would be mainly used up in expanding the air, and any circular motion would be slight on account of the friction between the air masses. With the formation of cloud the insolation which would otherwise reach the surface of the earth is largely absorbed into the system, adding to its energy, while a third source is to be found in the general circulation of the atmosphere.

The main source of energy seems to be the condensation of the water vapour, in this differing from extratropical cyclones. We should therefore expect cyclones to form only in regions where the air contains the greatest quantities of moisture, i.e. on the western sides of oceans, and at a time of year when evaporation has reached its maximum. Both these conditions we find fulfilled. The storms in the Bay of Bengal and in the Arabian Sea do not contradict the general statement, for they occur at the periods

of calm between the monsoons, and when the air is full of moisture. At the summer solstice the air in the regions where they occur is no longer still, the south-west monsoon prevailing at the time, and so we should not expect storms to develop at that period. On the eastern side of the oceans the winds are coming off the land, and are not sufficiently moisture-laden to establish these cyclones.

(3) If of thermal origin they will be comparatively shallow. They never originate over land, and are generally speedily destroyed on passing from the sea to the land. If they do continue their course on land or pass from tropical regions to mean latitudes, they lose all the characteristics of a tropical cyclone and assume those of an extratropical cyclone. That they are shallow appears from the fact that a ridge of even a few thousand feet is sufficient to arrest and destroy them. In this they are different from depressions which, though they do prefer following the sea in their path, yet frequently pass from sea to land and traverse large areas of land without being destroyed.

These considerations seem to point to a thermal origin, but comparatively few observations have hitherto been obtained within these storms, and so the conditions from the surface up to and in the stratosphere over these cyclones are not known with the accuracy that those in extratropical cyclones are. Should observation show that the temperature within the cyclone is less than that in the surrounding air at the same level, and that this difference is greater than can be accounted for by the difference in pressure, then the thermal theory of origin would require to be modified.

But the general behaviour, time, place, and frequency of occurrence all tend to point, if not to a different origin, to at least a different position of origin from that of extratropical cyclones, and to a different method of maintenance.

C.—TORNADOES, WHIRLWINDS, WATERSPOUTS

TORNADOES

The word tornado is of Spanish origin and was originally applied to storms occurring off the African coast in which a quick change of wind took place, but it has now come to be used almost exclusively for certain violent storms occurring in the United States of America. In America they are principally confined to the

southern states and to the flat country there, the valleys of the Mississippi and the Missouri being the home of the tornado. In the mountainous districts of the Rockies and Appalachians they are not met with at all.

CHARACTERISTICS.—These storms are very small in lateral dimensions, but they are the most violent and destructive of all storms. They occur on the southern side of a depression in the Northern Hemisphere, and average about 1000 ft. in diameter. One of the chief characteristics of a tornado is the funnel-shaped cloud stretching from the heavy storm-cloud down to the surface of the earth. A tornado therefore may be defined as an extremely violent vortex with a funnel-shaped cloud and a small diameter.

FREQUENCY OF OCCURRENCE.—These storms occur most frequently in the spring and summer, and during the afternoon from 15 h. to 17 h. Their life is very short, lasting at most only a few hours. Tornadoes experienced during the evening have been prolonged from the afternoon. They are scarcely ever experienced during the morning.

PROBABLE CAUSES.—They appear therefore to be caused by rapid convection and by the juxtaposition of warm and cold masses of air. With cold air in the upper layers the atmosphere becomes very unstable on the heating of the lower layers, and when convection sets in, the whole system breaks down with almost explosive violence. Thus several tornadoes may exist in close proximity and move along parallel paths, for some time maintaining their identity. In some of the depressions where they occur, there is a V-shaped bulge in the isobars on the southern side, so that there is a very distinct wind-shift line causing a quick transition from a south wind to a west or north-west wind. The temperature difference between these two currents is very marked, so that the isotherms are grouped closely together. This type of chart is associated with line squalls accompanied by thunderstorms in Europe. These characteristics, however, are not in themselves sufficient to determine when a tornado will occur and when it will not, for they have been found to occur even when several of these characteristics are wanting.

As they occur on the southern side of a depression, they move eastwards or north-eastwards. Violent thunder and lightning always attend them, and the funnel-shaped cloud is usually associated with the front of the thunderstorm. Little rain falls in front

of the funnel cloud, the rain coming with the cloud, and behind it there is generally hail.

EFFECTS.—The destruction wrought by a tornado is enormous. Owing to the excessively violent winds, pressure diminishes very rapidly within the storm. No record has ever been obtained of the pressure in the centre, as all instruments have been destroyed which have come in its path; but from records of stations near the path, it appears as though within the storm pressure became reduced to half its normal value. Now the average diameter is only about 1000 ft. and the velocity of translation is between 30 and 40 miles per hour, so that the reduction of pressure at any one spot is exceedingly rapid. By this rapid reduction in pressure everything coming in the path of the tornado appears to burst with explosive violence; for example, houses are not blown in, but apparently burst asunder. The whole effect of a tornado is weird. Trees are uprooted and split into fragments; feathers are stripped off birds; straws are driven through boards, and boards through iron gates, so great is the momentum owing to the violence of the wind, in spite of the small mass of these articles. Human beings, cattle, and horses have been lifted and carried some hundreds of feet, sometimes escaping almost without injury, but more often being dashed to death. A description of a tornado, in which nearly a whole family of six were destroyed, is given by Professor Ward in the *Quarterly Journal of the Royal Meteorological Society*.¹ This storm occurred on 30th May, 1879. Others of historic interest are the tornado of 26th July, 1890, which occurred at Lawrence, Mass.; another at St. Louis on 27th May, 1896; a third at Omaha on 23rd March, 1913. The velocity of the air near the ground in the storm of 27th May, 1896, exceeded, according to the calculations of Bigelow, 250 m. per second.²

WHIRLWINDS

The whirlwind of the desert is similar to the tornado of the United States. Over a desert region there is not sufficient moisture to form the cloud that accompanies a tornado, and there is no funnel cloud, no precipitation, and no thunderstorm. But the intense heating of the surface layers over a desert are sufficient to cause very rapid convection, and thus very violent winds arise and a big local reduction of pressure. The sand from the

¹ *Quart. Jour. Roy. Met. Soc.*, Vol. XLIII, p. 321.

² *Monthly Weather Review*, Aug., 1908,

desert is whirled into the air, and everything in the path of the whirlwind is destroyed. Diminutive whirlwinds may be seen on a hot summer day on a dusty, country road, the dust rising in a whirl from the roadway.

Occasionally a sandstorm moves across the desert in a long front. This is due to a line squall passing across the country, but as the air contains very little moisture, no precipitation and no thunderstorm accompany it.

WATERSPOUTS

When a tornado passes over a water surface the water becomes very agitated, and is drawn up some 8 or 10 ft., and of course the spray is drawn much higher, by reason of the great reduction of pressure at the centre. The same phenomenon is occasionally seen, but in a less degree, in this country, when a line squall passes from the land to the sea. Such phenomena are known under the name of "waterspouts". Plate X (*a*) represents a typical waterspout. Three miniature waterspouts occurred off Aberdeen associated with a line squall which passed over the city on 14th October, 1912. Before they passed from the land to the sea, all light objects, such as leaves and straws, over which they passed were raised off the ground and whirled upwards to considerable heights. When they passed to the sea the water below became violently agitated, indicating the effect of the motion of the air within the vortices. But though waterspouts tend to churn up the water surface, large quantities of water are *not* drawn up into the clouds. The water that falls from a waterspout is always fresh water, and is the result of condensation.

In all cases of tornadoes, whirlwinds, waterspouts, and allied phenomena, a large temperature gradient is essential. This produces rapid convection, without which these phenomena cannot occur. Another proof is thereby given of how essential it is for a forecaster to have as complete information as possible regarding upper air temperatures.

D. LINE SQUALLS

CAUSE.—When the trough of a depression passes, the wind on the southern side of the centre veers rapidly towards west or north-west, pressure begins to rise, and temperature falls quickly, accom-



a. A Waterspout



b. A "Line Squall" Front

From pastel drawings by G. A. Clarke, F.R.P.S.

panied by a shower of rain. Sometimes the wind falls away for a time after the veer, and then increases again. Behind the trough the gradient is generally slightly less than in front of it.

These changes which take place on the passage of the trough are attributed to the invasion of the moderately warm south-west current by a cold north-west current. If the depression is V-shaped the changes take place with much greater violence, and the veer is often attended with violent squalls of wind accompanied by heavy showers of rain and hail, and sometimes by thunder and lightning, indicating great atmospheric instability. Such a phenomenon is known as a "line squall", and it occurs at the junction of the two currents, between which there is a considerable difference of temperature.

Often the junction of the two currents is not along the line of the trough of the depression, but in advance of it. In such a case the warm current may be advancing from between south and south-west, and the cold current from between south-west and west. Consequently after the veer, which takes place on the passage of the squall, the wind may back again to south-west, a permanent veer towards north-west not taking place until later, when the trough passes.

CHARACTERISTICS.—When the squall bursts over a station, a sudden increase of pressure amounting to 1 or 2 mb. or more takes place. After this sudden increase, pressure generally falls slowly again as the squall line is often in front of the trough of the depression, afterwards showing a steady rise when the trough line has passed. The duration of the fall before this steady rise sets in depends on the position of the squall front with reference to the trough line. Along with the increase in pressure, a rapid veer of the wind takes place together with a very marked fall in temperature, the fall amounting often to several degrees.

The currents causing the squall meet along a front almost regular, extending sometimes to over a thousand miles in length, so that the squall advances across a country with a very wide front. The depth of the squall is very small compared with its length, however, so that in the passage of the squall a long, narrow strip of country is affected at one and the same time. The squall line extends almost right up to the centre of the depression, but practically never beyond it. There have been occasional slight evidences of the effect extending beyond the centre, but they are exceptional,

and in general it may be stated, therefore, that line squalls are confined to the equatorial side of a depression.

Each line squall, like each depression, has its own rate of advance, and these velocities range from 20 to 50 miles per hour.

The results of a detailed investigation of several line squalls have been given by Messrs. Lempfert and Corless in the *Quarterly Journal of the Royal Meteorological Society*.¹ The sudden increase

in pressure, the rapid veer of the wind, accompanied by heavy showers, are shown taking place along a line moving parallel to itself across the country. In the line squall of 8th February, 1906, the squall front travelled in twenty-four hours from the Hebrides almost to Clermont-Ferrand in central France. As the squall passed over Kew, the sudden increase of pressure amounted to 3 mb., the temperature fell 4° A., the wind changed suddenly from south-west to north-west in a squall of 45 miles per hour, thereafter decreasing to below its previous value, and precipitation amounted to 3 mm. Over south-east England the passage of the squall was attended by thunderstorms and hail.

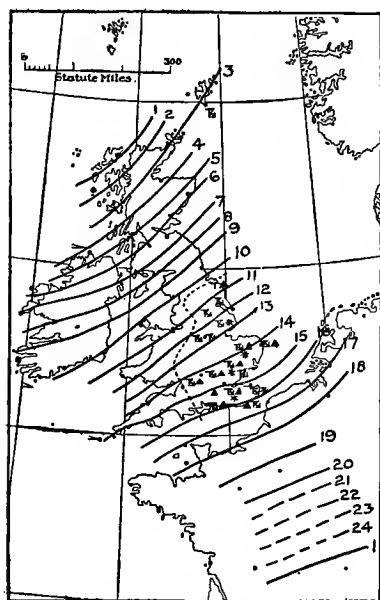

Fig. 78.—Progress of Line Squall of 8th February, 1906 (Lempfert and Corless)

The hourly positions of the squall front and the area of hail and thunderstorms are set forth in fig. 78.

In this squall a cold north-west current replaced a warm south-west one, the north-west current advancing right across the British Isles in less than twenty-four hours.

A similar squall of historical interest is the "Eurydice Squall", which took place on 24th March, 1878, when H.M. training ship the *Eurydice* was capsized. A day of brilliant sunshine was suddenly transformed into wintry weather accompanied by a snow

¹Line squalls and associated phenomena, *Quart. Jour. Roy. Met. Soc.*, Vol. XXXVI, pp. 135-170.

squall. Here again we have the cold north-west current replacing the warm south-westerly current.

Air Motion in a Line Squall.—The colder current which is invading the warmer is denser, and therefore tends to force the lighter current upwards all along the line where the two meet. There is thus a quick transition from the conditions within the one current to those within the other, and in this abrupt change is found the cause of the squall.

The two currents are in general associated with the front and the rear of a depression, but not always, as after the rapid veer of the wind to north-west it sometimes changes back again to south-west for a time, indicating that the two currents must be moving in almost parallel lines, with the squall taking place at their junction.

When the warm air is raised up it cools, condensation takes place, and the precipitation connected with the squall is produced. The heat liberated by the condensation helps to maintain the upward motion, and so the process continues if there is a sufficient supply of warm air. To render this possible the component velocity of the south-west current perpendicular to the front must be less than the velocity of propagation of the squall front. If these are equal, no vertical motion can take place, and therefore no squall.

Lempfert and Corless¹ have shown that the component of velocity of the cold current normal to the front is generally less than the velocity of propagation of the front, so that downward motion must take place behind the front to supply the deficiency in air. Thus in a squall there is upward motion in front and downward motion in the rear, and this air which is descending cannot be that ascending in front, otherwise the following current deprived of its moisture would descend as a current warmer than when it left the earth's surface. This, however, would be contrary to observation, so that circulation about a horizontal axis does not take place. The down current must therefore be drawn from the cold current, and the rising current joins the upper following currents. These rising currents are not retarded to the same extent by friction as the surface currents, and the top of the squall moves in consequence more quickly than the lower part. A phenomenon analogous to the breaking of waves is therefore to be expected, and may be connected with the recrudescence of the phenomena of the squall which occurs in certain cases.

¹ *Loc. cit.*

For steady motion the component velocities perpendicular to the front in front and rear of the squall will be equal. Let these velocities be each represented by u , and let the components of the gradient winds in the same direction be each equal to v . The squall front, as indicated above, must travel more quickly than the surface component, so that it gains upon the wind in front, and leaves behind the following wind, which must therefore be augmented by air descending from above. Let the velocity of the squall front be U where $v > U > u$. Then the squall front is moving forward "through the air" at a velocity $(U-u)$.

Such a circulation as this explains the various phenomena associated with a squall, the mass of colder, denser air replacing

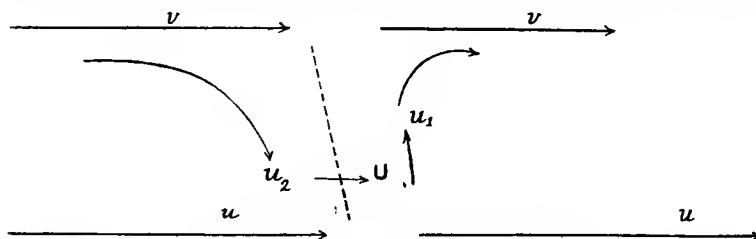

Fig. 79.—Circulation of Air in a Line Squall

the warmer, and bringing about the sudden increase of pressure and the rapid fall in temperature, together with the sudden veer in the wind. The precipitation arises from the elevation and consequent cooling of the warm moist current in front. At the junction of the two currents the isobars, as barograph records show, are very much distorted, and thereby are brought into close juxtaposition along the squall line. An impulsive flow of air is thereby produced, as Shaw points out, which may account for the violent squall along the line of separation. The thermograph records during the passage of a line squall often show successive rapid falls of temperature accompanying a general fall. Such successive "steps down" of temperature can be accounted for by the upper part of the squall breaking like waves on the sea.

Evidence of the uprising current in front is seen in the formation of the squall cloud, for small fragments of cloud come into being some distance below the main cloud and then rush up to join it.

Fig. (b), Plate X (p. 244) represents the cloud associated with

a line squall which passed over Aberdeen on 14th October, 1912. Mr. G. A. Clarke, King's College Observatory, gives the following description of its passage from notes made at the time. "Rain had been falling all the morning up to seven o'clock, after which the nimbus cloud cleared away, showing a sheet of grey altostratus above. The temperature was rising, and stood at 59° F. at 10.20 a.m., and a gentle moderate wind was blowing from south-south-west. At about 10.24 a.m. a sudden puff of wind followed by sharper gusts came from the west-north-west, and a patch of cloud formed rapidly in the south-west, lying along a line from south-south-west to north-north-east. . . . By 10.26 a.m. the cloud had become a long band of cumulus cloud stretching right across the sky and followed in the rear by a sheet of dark-grey cloud. The cloud-band and sheet passed rapidly eastward, and as it reached the coast-line the cumuliform appearance gave place to a ragged form. At 10.28 a.m. the cloud-bank had passed out over the sea, and almost suddenly a large number of wisps of cloud formed beneath the cloud-bank and rose up rapidly into the main cloud mass. Following the formation of these wisps of cloud, the whole cloud front at 10.30 a.m. appeared to be a mass of vapour whirling in vortices, while three waterspouts formed over the sea, moving downwards from the cloud but not reaching the water, which latter, however, showed their influence by the disturbance of its surface. At the same moment there came the heavy squall of 53 miles per hour from west-north-west, and the temperature dropped to 48° F., a fall of 11° F. A sharp shower accompanied the squall. North of Aberdeen the squall was evidently heavier, for factory windows were blown in, and whirlwinds of dust and dead leaves occurred. After the squall had passed, the upper cloud was seen to be moving from the south-west."

E.—THUNDERSTORMS

CAUSE.—Thunderstorms arise through instability in the atmosphere, and the thunder and lightning which accompany these storms are not the cause of the storms but simply the result. They are the inevitable consequence of the rapid condensation taking place in a huge cumulo-nimbus cloud, and play little, if any, part in the mechanism of the storm.

Under suitable conditions of temperature and humidity rapid

convection and condensation take place, forming thereby large cumulo-nimbus clouds, and it is in the formation of these clouds that we must look for an explanation of thunderstorms.

TYPES.—Thunderstorms may then be divided into two classes according to the cause whereby the instability of the atmosphere arises, and these two classes are heat thunderstorms, and thunderstorms associated with depressions.

Heat Thunderstorms.—In the hot season of the year the layers of air in contact with the ground become heated during the early part of the day, and if the temperature gradient be large, rapid convection results, forming large cumulo-nimbus clouds. If the temperature gradient be small, or if there be an inversion of temperature in the upper layers, the convection currents will be feeble, and if clouds form at all they will only be small cumulus clouds. A large temperature gradient is therefore essential. Under these conditions cumulo-nimbus clouds rise to great heights, and so violent is the up-rush of air within these clouds that they often become fringed with false cirrus as in Plate VII (*a*) (p. 168), spreading out at the same time into an anvil shape.

When the cloud forms, a descending air current begins to arise behind and beneath it, for the air above, being colder and denser than the air on the surface, forces the surface air upwards and then rushes down to take its place. This cold current has a forward velocity in the direction in which the storm is moving. The ascending current on the other hand has a small velocity at the surface in the opposite direction, through the air above it being drawn backwards into the advancing storm-cloud. This explains the sudden shift in the wind direction which takes place as the storm breaks over a station. At some distance in front of the storm the wind is nearly calm or has a direction nearly the same as the following wind. Two wind shifts therefore take place, one in front of the storm and the other just as the storm begins.

Between the ascending and the descending currents a turbulent motion is often seen to arise, but the air which reaches the surface of the earth is cold air, and must therefore be drawn from the cold upper layers and not from the warm ascending air, so that the turbulent motion is not a simple motion about a horizontal axis.

Warm, moist, and rapidly ascending air currents are necessary for the formation of these thunderstorms, and consequently they occur with greatest frequency in the summer-time and during the

afternoon, over land areas from which sufficient moisture can be drawn. Storms of this type are never experienced over the open ocean outside the tropics because the surface temperature does not rise sufficiently high to give a rapid temperature gradient; neither are they found to occur over deserts because there the air is too dry for the formation of cumulo-nimbus clouds. Over inland districts where there is sufficient moisture, they are much more frequent than on the coast.

Rapid rise in temperature causes a small local depression, and therefore in a certain sense these storms are depression thunderstorms. But these depressions are very shallow, seldom extending far into the atmosphere, so that the case is entirely different from that of thunderstorms due to regular depressions.

These storms are often very local, and occur with great frequency over mountainous districts. Over some of the mountainous islands in the tropics they are of almost daily occurrence. The ascending moisture-laden air generates huge cumulo-nimbus clouds during the forenoon, the thunderstorm breaks forth in the afternoon, and then towards the evening the sky clears through the descent of the air, not a trace of cloud being visible in the starlit sky at night. The clouds form at comparatively low altitudes, the mountain tops often being visible above the storm-cloud. This is due to the large amount of moisture in the atmosphere. In districts such as the Alps, the clouds form at greater heights, as there the amount of moisture is much smaller and greater elevation is required before condensation takes place, but in both regions the phenomenon is exactly the same. Occasionally through the drift caused by currents in the upper layers of the atmosphere, several of these local thunderstorms unite over a region such as the Alps, so that the storm embraces quite a wide area at one and the same time.

Thunderstorms on the Coast.—These may be regarded as a subdivision of heat thunderstorms. If after a warm spell a colder current sets in from the sea, fog is often experienced on the coast, but occasionally instead of the fog forming, a belt of cumulus cloud forms. This occurs frequently on the north-east coasts of France when a westerly wind is blowing up the Channel, and the cloud is probably due partly to the rising air currents and partly to lifting caused by the land. Occasionally these clouds become sufficiently developed to cause thunderstorms. Such storms, though

attended with violent squalls on the coast, often dissipate rapidly on moving inland. A thunderstorm of this type occurred in August, 1918. On the coast the squall was exceedingly violent, causing damage to tents and hangars. 15 Km. inland it was still sufficiently violent to break branches from trees and strip off leaves, but at 50 Km. inland it had entirely disappeared.

Thunderstorms Associated with Depressions.—Instability in the atmosphere can be brought about by a cold current undercutting a warm current, as shown in the section on line squalls. In every depression there is present on the equatorial side of the centre this dividing line between the warm current and the cold current. If then condensation is sufficiently active along this line, thunderstorms may arise. The sudden rise of pressure, the rapid veer of the wind, and the fall in temperature as the squall advances have all been dealt with in the previous section. On the barograph trace the rise of pressure appears as a line practically vertical, and amounts to 1 or 2 mb., and at times to more. As thunderstorms are often associated with this rise, it has been termed by the French a "crochet d'orage" and by the Germans a "Gewitternase". It takes place along the whole line dividing the two currents, thus reaching from the edge of the depression right up at times almost to the centre. This line along which the initial squall or "grain" takes place is termed a "ligne de grain". It is often sinuous, as the velocity of the two currents at the surface is in part determined by the nature of the ground over which they are moving.

The phenomenon of the line squall is not present on every occasion, but it is very frequent in big thunderstorms, and the storm always begins with the passage of the line. That the thunder and lightning are due to the storm and not the cause of the storm is evidenced by the fact that these occur only where the conditions are such as to produce abundant condensation. If these conditions are absent, there occur only the wind squall and perhaps some slight precipitation, but no electrical phenomena. Thunderstorms are likely to occur, therefore, with greatest frequency after the warmest part of the day. But their frequency will also depend on the number of depressions, and as depressions are most frequent in winter and are more confined to the sea than to the land, these storms should show their highest frequency in winter and over the ocean. In winter, however, temperatures are much lower, and

therefore the quantity of moisture in the atmosphere is often insufficient to produce thunderstorms, so that the ratio of their winter and summer frequencies is less than that of the frequencies of depressions.

Distribution of Thunderstorms.—In high latitudes where the temperature remains low all the year round, heat thunderstorms are practically unknown. Depression thunderstorms are also rare because the amount of moisture in the air is small. The total number in these latitudes is therefore small, and those that do occur take place in winter, the season when depressions are most frequent. Thus in Iceland, over a period of 14 years, only 33 thunderstorms occurred, and of these 22 were experienced in winter.

In mean latitudes heat thunderstorms occur everywhere on the continents in summer, but are much less frequent on the coasts. Depression thunderstorms on the other hand are much more frequent on the coasts than inland, and have their greatest frequency in the winter. This difference in behaviour takes place within very narrow limits. At Brest the total number of thunderstorms is much smaller than at Paris, but the frequency of the winter thunderstorms is much greater at the former station than at the latter.

In equatorial regions thunderstorms are much more frequent than in other latitudes, except over desert areas where there is insufficient moisture to produce these storms. All tropical thunderstorms are heat thunderstorms, for storms associated with tropical cyclones are not of the type of line-squall thunderstorms. Nearly all the rains of tropical regions are accompanied by thunder and lightning, and at certain seasons of the year these thunderstorms occur almost every day.

In all latitudes thunderstorms occur with greatest frequency between midday and 18 h. Their number diminishes until after midnight, and the period during which they are least frequent is between 3 h. and 6 h., i.e. at the time when surface temperature is at its minimum.

Rainfall in Thunderstorms.—The rain does not fall continuously during these storms, but generally in very heavy showers. Often the rain, after almost ceasing, renews itself with great violence after a lightning flash, large drops falling at first and then smaller drops. But the velocity of a drop

through the air depends on its size, and so, though both large and small drops were formed at one and the same time, the large drops would naturally reach the earth first. It has been suggested that the sudden increase in rain is due to the lightning flash, but it appears rather that the lightning flash is due to the shower. For if several small drops unite to form larger drops, precipitation will take place and the air will become more conducting through the passage of the raindrops. The reason that the rain falls to the ground *after* the flash has been seen is that the time taken by the drop to fall is much longer than the time taken by the light to travel, which is infinitesimal.

The rainfall in a thunderstorm is therefore distributed in an entirely different way from that generally associated with a depression. Instead of the rain commencing with small drops, and the drops increasing in size towards the centre of the storm and then decreasing again, the heaviest drops in a thunderstorm fall at the commencement, and the size decreases towards the end. Also frequent renewals of very heavy drops occur during the passage of the storm, a phenomenon peculiar to thunderstorms. The size of the drops is accounted for by the cumulo-nimbus cloud and the large convection currents within it.

Hail in Thunderstorms.—Large hail is always associated with thunderstorms. The upward currents within a cumulo-nimbus are very strong, so that they reach to great heights, 4000 to 5000 m. At these heights temperature is always below freezing-point, and especially under conditions necessary for the formation of these clouds. Within the cloud the water-drops become supercooled. Such a condition is an unstable one, and if these drops come in contact with a small ice particle, some of them will immediately freeze, and the temperature will rise to 273° A. The number of drops that freeze out depends on the original temperature, the lower that temperature the greater the number frozen out. If these drops now remain in a layer of air under 273° A., they will finally all freeze out.

By reason of the violent upward currents in the cumulo-nimbus some of the water vapour is carried into regions where it passes directly into the ice stage, and the cloud becomes fringed at the top with a veil of thin cloud consisting of ice particles, and known as false cirrus, shown in Plate VII (*a*) (p. 168).

In the cumulo-nimbus there exist, therefore, under these con-

ditions, ice crystals formed at the top and supercooled water-drops formed lower in the cloud. When these come in contact, the supercooled drop immediately freezes out, the two uniting to form one. Then through the currents within the cloud these small hailstones may be carried several times through the super-saturated layer, and each time a new layer of ice is added to each. There is a certain amount of air within the water drops, and when they freeze out the air is retained in the interstices between the ice crystals, rendering the hailstones opaque.

Finally, as the hailstones grow, the upward currents are no longer able to sustain the weight, and so they fall to the earth. Hail is generally confined to a small area of the storm, often covering only a few hundred square yards, whereby at any particular station hail frequency is low.

The velocity of hail, like that of raindrops, depends on its size, and so large hailstones often cause great damage. Several methods have been tried to overcome the hail danger, but these are practically all based on the assumption that the hail is produced by the electrical phenomena. Now the hail has its origin in the convection currents and not in the electrical phenomena at all, consequently these methods are unlikely to afford any practical results.

CHAPTER VIII

The Free Atmosphere

With the invention of the barometer, thermometer, &c., in the seventeenth century it became possible to make comparatively accurate observations of the meteorological elements at the earth's surface, and as these instruments became more perfect the accuracy of the observations increased. From these observations, made in reality at the bottom of a vast ocean of air, all theories regarding the general circulation of the atmosphere, formulated during the eighteenth and the greater part of the nineteenth centuries, arose. Towards the end of the nineteenth century, and especially during the last decade of that century, greater attention began to be paid to the upper or free atmosphere. The present century has seen a great development in that direction, and the result has been that certain theories, especially those regarding the origin of depressions of mean latitudes, have had to be abandoned and new theories developed.

In the investigations of the free atmosphere, kites, free manned balloons, captive balloons, ballons-sondes, pilot balloons, and more recently aeroplanes, have all been pressed into the service.

The first attempt to find the temperature in the free atmosphere was made by means of thermometers attached to kites. Professor Wilson, of Glasgow, in 1749, raised a number of paper kites, one above the other, thermometers being attached to the most elevated.¹

Early Investigations.—In 1752, three years later, Franklin obtained electrical discharges from a thundercloud by means of a cord carried by a kite. In the winter of 1822–3, Captain Sir Edward Parry and the Rev. G. Fisher obtained upper-air temperatures in the Arctic regions by using self-registering thermometers attached to kites. Espy used kites in 1840 to verify

¹ *Trans. Roy. Soc., Edin.*, Vol X, pp. 284–6.

his calculations regarding cloud heights and humidity, and at Kew kites were used in 1847 by Birt for the measurement of the changes of wind, temperature, and humidity with height.

Glaisher, at the instigation of the British Association, began in 1862 to explore the free atmosphere by means of manned balloons. This work was spread over the period 1862-6. One of the earliest and most notable ascents took place in 1862, on 5th September, when an estimated height of 11,200 m. was reached. Both Glaisher and his companion, Coxwell, fainted, however, at a height of 8900 m., so that the exact height could not be determined. Subsequently Glaisher supplemented these free balloon ascents by observations made in 1869 by a captive balloon at Chelsea.

In 1883, E. D. Archibald, of Tunbridge Wells, made observations of the wind by means of anemometers of the Biram type. These anemometers were suspended by means of kites in the different layers of the atmosphere, four anemometers being suspended at different levels at the same time. Archibald appears to have been the first to employ steel wire in kite-flying.

These early observations showed that the temperature of the free atmosphere decreased with height at the rate of about 1° F. for 300 ft., or 0.6° C. for 100 m., so that even near the Equator the summits of the high mountains are above the snow-line.

Investigation by Kites.—Systematic observations of the upper atmosphere were commenced at Blue Hill by the late Professor Lawrence Rotch in 1894. His original method was to send up self-recording instruments attached to the wire of a kite. A train of kites was used, the wire consisting of fine piano wire, and a steam winch being employed to wind in the kites. By this means Rotch was enabled to obtain records of temperature and humidity up to a considerable height. A report on the work was presented to the International Meteorological Conference in Paris in 1896, and in 1898 the International Aeronautical Committee recommended the kite and the kite-balloon to be included among the apparatus of all principal observatories. A kite station was equipped during that year by Teisserenc de Bort at Trappes. In the few following years kites were used in various quarters. Three series of observations were made over the Atlantic by Hergesell, de Bort, and Rotch between 1904 and 1906, and regular observation stations were established in England from 1907 onwards at Pyrton Hill, Glossop, and Ditcham Park. In 1902

W. H. Dines carried out a series of observations from a small steam vessel on the west coast of Scotland, as well as observations over land. 1905 saw observations carried out in India at the request of the International Committee, and a similar station was established in 1907 in Egypt.

De Bort in 1902-3 also carried out a series of observations at Hald, in Jutland, kites being flown day and night whenever possible over a period of nine months. Later he continued his investigations over the Baltic, and during this period a height of 5900 m. was reached.

Ballons-sondes. — Several suggestions were made during last century to use small, free balloons to carry self-recording instruments, but no satisfactory instruments were devised until near the end of the century. In 1894 a silk balloon, the "Cirrus", of 250 cu. m. capacity, was constructed, and between 1894 and 1897 made eight ascents from Berlin, the highest ascent being made in September, 1894, when the balloon rose to 18,500 m. All the instruments attached to the "Cirrus" were enclosed in an aspirated tube designed by Assmann.

In order that uniformity might be obtained in the methods of investigation a committee was appointed by the International Meteorological Conference in Paris in 1896, to arrange for international ascents. The result was that four manned and four registering balloons were sent up from France, Germany, and Russia on the same dates in 1896. Austria and Italy joined in these ascents in 1898, Belgium in 1899, and England in 1901.

In addition to these international ascents, de Bort carried out a large number of ascents between 1898 and 1902 with small free balloons or ballons-sondes, the number of balloons released being 258. This method of observation extended to other European countries and also to America, where Rotch made the first series of registering balloon ascents in 1904. From 1901 the international ascents had taken place on the first Thursday of each month, and from 1907, at the instigation of the International Committee, which at their meeting in Milan in that year determined to carry out observations on a more extended scale, all European countries which had previously taken part in the monthly ascents now participated in the new series which included ascents of several balloons on successive days at stated periods. In addition some special ascents have been made, such as the ascents

made at Manchester when balloons were liberated every hour over a period of twenty-four hours.

Pilot Balloons.—Pilot balloons were first used in 1809 by Thomas Foster, but were apparently discontinued until their use was revived by Le Verrier in 1874. In 1877 a series of small balloons were sent up from Paris to investigate the changes of wind direction with altitude, and to determine the height of the clouds. This method soon came to be adopted in other countries, and in 1877 it was decided to use these small rubber balloons regularly in Arctic work. They are now used extensively at all meteorological stations for determining, with the aid of one or two theodolites, the velocity and the direction of the wind in the different layers of the atmosphere. They are very much handier than kites, and also they can be sent up in calm weather when it is impossible to fly a kite. Kites are also limited in the heights to which they reach, whereas pilot balloons are not so limited.

Cave, in *The Structure of the Atmosphere in Clear Weather*, has shown how soundings with pilot balloons can be employed to reveal the strength and direction of the currents in the upper air in the various pressure systems. From these soundings the distribution of the isobars and the isotherms at different levels can also be determined by a method given by Shaw in his *Principia Atmospherica*.¹

A. INSTRUMENTS

It soon became apparent that ordinary barometers and thermometers were not suitable for work with kites and balloons by reason of the sudden shocks and jars to which they were subjected, and so light, self-recording aneroid barometers, Bourdon tube-thermometers, and hair-hygrometers were substituted instead. The record was made by levers on smoked paper wrapped round a revolving drum. Glaisher's experiments indicated that the fall of temperature decreased considerably in the upper layers, but this result was soon shown to be in error through the thermometers being insufficiently shielded from insolation. So methods were devised whereby the instruments should be properly shielded from the direct rays of the sun, and at the same time properly ventilated. In 1898 the Assmann psychrometer was recommended

¹ *Proc. Roy. Soc., Edin.*, Vol. XXXIV, pp. 77-112.

as the only suitable instrument for recording temperature and humidity in manned balloons. It was further recommended that it should be hung 5 ft. below the car of the balloon. At a meeting of the International Committee in Berlin in 1902, a compact instrument for use with ballons-sondes and weighing only 500 grm. was exhibited by Assmann. Other instruments were exhibited at the same time by de Bort and Hergesell. A different type of instrument was at this same time being evolved by Dines in England. Finally two types of self-recording instruments were evolved, one employed on the Continent and in America, the other in the British Isles and in some of the colonies. These instruments are known as meteorographs.

Kite Meteorographs.—The Kite Meteorograph used on the Continent is a baro-thermo-hygro-anemograph. There are different modifications of these instruments, the Richard Frères' meteorograph, the Marvin instrument, and the Bosch-Hergesell meteorograph. In the Richard Frères' instrument the barometer is a double aneroid, the thermometer a Bourdon tube filled with alcohol, the hygrometer a bundle of hairs, and the anemometer one of the Robinson cup type. Each part of the instrument records separately on a sheet wound round a revolving drum. Ventilation is obtained by means of an opening in front of the case and holes in the back, while the instrument is kept head on to the wind by a vane.

The Dines Kite Meteorograph is entirely different. The frame is a wooden tray in the middle of which a flat, circular disk is caused to rotate by means of a small clock. The pressure and humidity are recorded on one half of this cardboard disk, and the temperature and wind velocity on the other half. The barometer is a single aneroid and the thermometer a long, thin copper spiral filled with alcohol. The hygrometer consists of a bundle of hairs placed in a ventilation tube, while the anemometer consists of one or more light spherical balls suspended from a lever by about 40 ft. of thread. The pull on the balls is balanced by a spring in such a way that the deflection is proportional to the wind velocity. The whole instrument is suspended within the kite, as the thread is sufficiently long to allow of the balls being outside the influence of the kite. The continental instruments, on the other hand, are hung some distance below the kite so that the anemometer may not be influenced by it. This method does

not afford the same protection to the instruments on ascending and descending as the Dines method affords.

Ballons-sondes Meteorographs.—The first instrument used by de Bort was a baro-thermograph consisting of an aneroid barometer and a Bourdon tube alcohol thermometer. This was abandoned, however, and the instrument finally used by him was a Bourdon tube barometer, a bimetallic thermometer, and a hair hygrometer. The thermometer consists of a strip of brass and steel soldered together, the end fixed to the instrument being insulated from the frame by a block of rubber to prevent conduction of heat from the frame. The thermometer tube and the hairs of the hygrometer are exposed during an ascent, the rest of the instrument being enclosed in a cork case.

With this instrument the scale is:—

1 mm. of mercury	=	about 0.08 mm. deflection
or 1 mb.	=	„ 0.06 mm. „
and 1° C.	=	„ 0.04 mm. „

The type of instrument used by Assmann in Germany is somewhat different, but like the de Bort meteorograph, it records the elements all separately. The barometer is a multicellular aneroid barometer, and the thermometer a bimetallic thermometer consisting of copper and invar strips soldered together. This thermometer and the hairs of the hygrometer are enclosed in a ventilation tube. The record sheet is wound round two cylinders, with their axes parallel. The expansion and contraction of the aneroid causes one cylinder to rotate, and the record sheet together with the other cylinder move with it. This movement of the sheet enables the pressure to be recorded. The temperature is recorded by a pen moving across the sheet parallel to the axes of the cylinders, the pen being connected by a thread and a system of levers to the bimetallic thermometer. Humidity is indicated in the same way. The instrument weighs in all about 620 grms.

In England a very much smaller instrument is used, viz. the Dines Meteorograph. Originally it was a baro-thermograph, recording only pressure and temperature. The barometer consists of a partially exhausted German silver aneroid, and the thermometer of a strip of German silver and a rod of invar. In this system the barometer and the record sheet remain fixed, while the thermometer moves bodily. In the later system the record con-

sists of a pressure-temperature diagram and a pressure-humidity diagram scratched on a small piece of thin metal, the size of a postage stamp, electroplated with silver, the whole weighing about 2 oz., i.e. about 57 grms. The record is very minute, and must be deciphered by a microscope, so that great care must be exercised in the calibration and in the use of the instrument.

Fig. 80 (Plate XI) gives a general view of the meteorograph arranged to read temperature and pressure. The barometer is the aneroid A, which, being only partially exhausted, opens under the reduced pressure, and the two parts of the frame BB, which are held together by the spring C, move apart. One side carries the plate, and the other the scratching point, so that when they move a scratch is made on the plate, which is practically the arc of a circle. Alteration in temperature causes a movement perpendicular to this arc, and is recorded by the expansion and contraction of the strip of German silver M. The thermometer consists of M and H, the bar of invar. The latter ends in a short spring, and both are soldered to the lever EFD, which gives a magnification of about 10. The control exerted by the aneroid box is sufficiently powerful to make the friction of the scratching points negligible. The whole is protected by a thin aluminium cylinder, with axis vertical, allowing the system to be ventilated by a stream of air passing over it as it ascends.

A second scratching point on the arm not carrying the plate gives a fiducial mark, and this shows whether the plate has moved in the holder between the calibration and the ascent. If movement has taken place, the scratch by the fixed point will be duplicated.

For the hygrograph a third scratching point is arranged to scratch about 4 mm. inside the temperature scratch, and the point is held by a short hair against a light spring.

A copy of a record is shown in fig. 81 (Plate XI), in which the trace is seen to cross the calibration lines from left to right.

For an ascent the instrument, fixed in the aluminium cylinder, is placed inside a bamboo frame, which is attached to the balloon. The bamboo frame is known as the bamboo "spider frame". To the instrument there is also attached a label instructing the finder to place the instrument, which is the property of the Meteorological Office, in a place of safety and to communicate at once with the Director of the Meteorological Office. A reward of five shillings is offered.

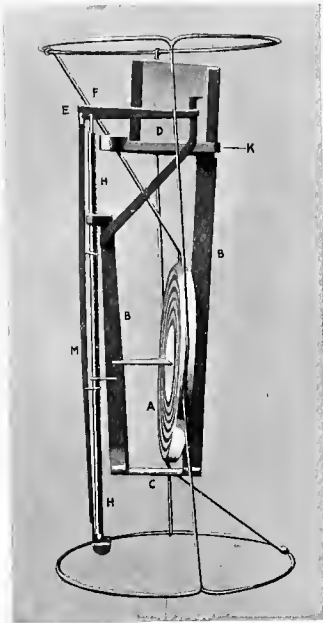

Fig. 80.—Meteorograph: general view

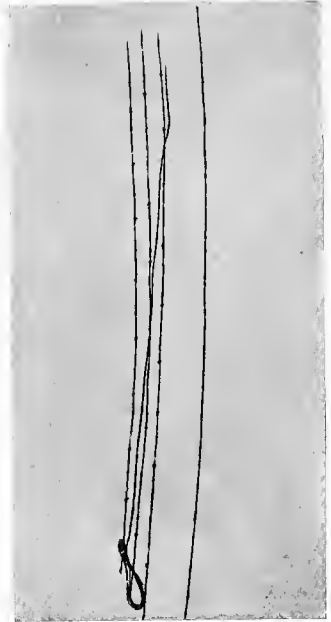

Fig. 81.—Record

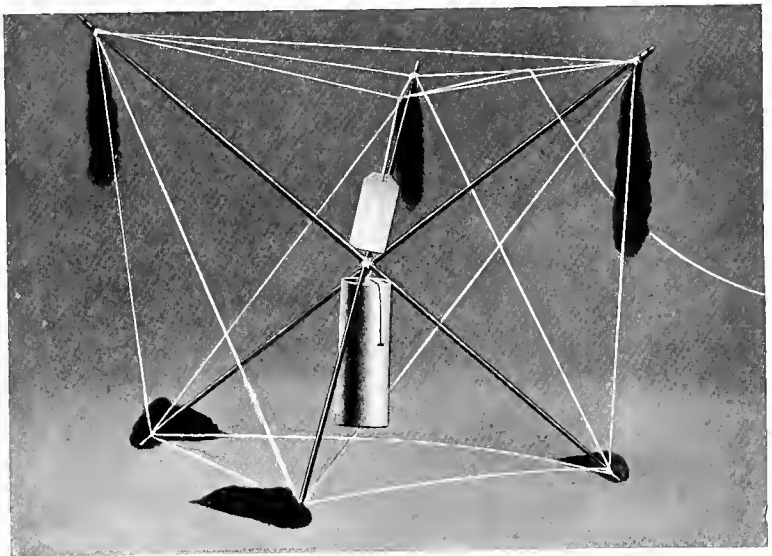

Fig. 82.—The "Spider"

Ballons-sondes Apparatus

The "spider", with the instrument attached, is shown in fig. 82 (Plate XI). This frame is hung 40 m. below the balloon. The angle that this distance subtends at the focus of a theodolite telescope enables an observer to calculate the distance the balloon is from him at any given time, and hence he can estimate the rate of ascent and the velocity of the wind.

TESTING OF INSTRUMENTS

Messrs. Gold and Harwood, on whose report to the British Association in 1909¹ the foregoing description of instruments is largely based, also in the same report indicate the methods of testing these instruments. The reliability of the results obtained by these meteorographs is likewise dealt with. For a full description of the testing of a Dines Meteorograph the reader is referred to the "Computer's Handbook, M.O. 223, Section II, Subsection II", from which the following is mainly culled. The instrument is placed in a brass cylinder filled with petrol, into which it fits easily. This cylinder is surrounded by a copper tube into which liquid CO₂ is run so that the temperature can be lowered to any desired value. The temperatures at which calibrations are carried out are 280° A., 250° A., and 220° A.

By means of an air-pump attached to the brass cylinder any desired pressure can be obtained. Three observations of pressure are first made at 280° A., the points being distributed over the whole range of pressure likely to be met with. As the end of the scratching point does not press on the metal disk during calibration, the three pressure points referred to are made by means of an electric striker which taps the thermograph. The striker and its armature are inside the vessel and the electromagnet outside. Temperature is then reduced to 250° A., and other three points marked in a similar way at the same pressure values as the first set, and finally three corresponding points at a temperature of 220° A. are found. The temperature of the petrol bath is determined by means of an air thermometer, graduated down to 210° A. Three parallel calibration lines appear on the record (fig. 81), with points corresponding to definite pressures marked on them.

New instruments should be calibrated some time during the

¹ Report to British Association, Winnipeg, August, 1909.

week previous to their being used. If a meteorograph is to be used a second time, it must be tested again before use.

On the Continent the method of testing is somewhat different. Thus in Germany the whole apparatus is put under the receiver of an air-pump, and the pressure reduced to various values. The receiver of the pump has triple cavity walls through which carbonic acid gas can circulate, and the temperature is thus reduced, and the temperature correction of the barometer determined for different pressures. An electric fan inside the receiver keeps the air in motion, and the temperature is indicated by a standard thermometer viewed through a window in the side of the receiver. The temperature correction for the barometer is thus obtained. The calibration of the thermometer is carried out at the same time. The hygrometer is calibrated by comparison with an aspiration psychrometer.

De Bort calibrated his barometer by placing it under the receiver of an air-pump, but made no temperature correction. His thermometer he placed in an alcohol or petrol bath, which he cooled to 203° A. by solid CO₂, and compared it with a standard thermometer.

B. RESULTS OF OBSERVATION

Dines, in a recent publication, *The Characteristics of the Free Atmosphere (Geophysical Memoirs, No. 13)*, gives an account of the material available at present regarding the conditions in the free atmosphere. According to him 90 per cent of the observations so far made have been carried out in Europe, where fifteen stations have participated in the investigation. Outside Europe observations have been carried on in the United States of America, Canada, Australia, and at Batavia. In all probability 2000 observations up to 10 Km. have been made, and of these England has contributed 450. These observations have been all carried out by ballons-sondes. For heights up to 3 and 4 Km. observations are much more numerous, as for these heights kites have been largely employed. Aeroplanes are also now being employed to obtain observations of temperature up to 5 and 6 Km. A meteorograph may be carried by these machines, so that a continuous record of the meteorological elements in the upper layers up to a certain height can be obtained in a much shorter time than by ballons-sondes.

But the region of greatest interest lies beyond the reach of aeroplanes, and ballons-sondes are the only means at present available for obtaining information regarding this region. Consequently the number of ascents made by these is steadily increasing, and so a large amount of information is steadily accumulating. This information is such that it has revolutionized to a large extent the ideas formerly held regarding the circulation of the atmosphere, and especially the ideas regarding the origin of cyclones and anticyclones of mean latitudes.

RELIABILITY OF THE RESULTS OBTAINED

As already indicated, the methods of observation adopted on the Continent are quite different from those in use in England; the magnification is produced in the first case by a system of levers, and in the second is obtained through examination of the record by a microscope. Yet though these methods are very different, the results obtained agree within the limits of experimental error. Also records from stations close together, such as Pyrton Hill and Ditcham Park, show very good agreement, so that if the records were incorrect this agreement would not always be found.

Dines shows that direct proof is afforded in two ways that the instrumental error is not greater than 1° A. on any particular occasion.

The first proof is afforded by two series of hourly observations carried out at Manchester, and extending over a period of twenty-four hours each. These observations show that *if* the temperature curve at each height is a smooth curve, then the probable instrumental error on these occasions was less than 1° A. Now perhaps the curve is not exactly smooth, but if the thermometers were at fault, the errors likely to arise would not tend to make it more smooth, but rather to make it rougher.

The second proof is afforded from certain very close and intimate relations existing between the pressures and temperatures in the upper air. If the results of the observations were wrong, such relationships could not exist. These relationships also lead to the conclusion that the probable error in the temperature is not greater than 1° A., and perhaps less.

The mean values have probably about the same accuracy. For only comparatively few observations are made every year, and as

some of these might be made on days when conditions were abnormal, then the mean values are probably in error to the amount of 1° A.

Method of working up a Record. — To work up a record obtained by a Dines apparatus, the plate with the trace is fixed to the stage of a microscope. The movement of this stage in one direction is measured by means of a micrometer attached to it. Another micrometer fixed at the focus of the eye-piece of the microscope has its divisions parallel to the calibration lines. The distance between the divisions of the latter correspond to 1° A.

The readings of the micrometer on the stage corresponding to the points on the calibration lines are first obtained. These values correspond to known temperatures and pressures. A series of readings on the stage micrometer, corresponding to a series of absolute temperatures as determined by the micrometer at the focus of the eyepiece, is now found from the actual trace. Both of these sets are plotted on squared paper with absolute temperatures as abscissæ and stage micrometer readings as ordinates. The second series gives the actual trace. From the first set a series of lines crossing the trace is found, each line corresponding to a definite pressure. Between these lines may be interpolated a series corresponding to pressures of 1000 mb., 900 mb., 800 mb., From the intersection of these lines with the trace, the temperatures corresponding to these pressures are determined. The heights corresponding to the pressures are now found with the help of semi-logarithmic paper, taking into account the temperature prevailing at the time. For if h be the vertical distance in kilometres between two points where the pressures are p_0 and p , then, neglecting the effect of humidity and variation of gravity,

$$h = .06740T \log \left(\frac{p_0}{p} \right),$$

where T is the mean temperature of the layer in degrees absolute. On semi-logarithmic paper this expression is represented by a straight line, having a definite slope for each value of T , and hence the graph may be drawn in sections, and the heights determined. The temperatures may then be written against the heights, and in this way the temperature at each kilometre above the surface is found for any individual observation. Mean values may then be determined in the ordinary way.

MEAN TEMPERATURES AND TEMPERATURE GRADIENTS

The most important meteorological element to be investigated in the free atmosphere is the temperature. From it and the pressure at the surface the distribution of pressure at the various levels can be determined, so that though dynamical meteorology is based on the distribution of pressure and density, yet it rests ultimately on the distribution of temperature. Gold¹ has given the mean temperatures for the different layers compiled from observations carried out between 1904 and 1909. The following table given by Dines is from Gold's values, with the exception of the temperatures for the British Isles, which refer to the period 1908-15. The values are also arranged according to latitude.

TABLE XIX
MEAN TEMPERATURES

Height in Km.	Petrograd.	Scotland.	Berlin.	England, S.E.	Paris.	Vienna.	Pavia.
	Deg. A.	Deg. A.	Deg. A.	Deg. A.	Deg. A.	Deg. A.	Deg. A.
14	223.5	220.0	218.7	218.9	219.1	219.6	217.7
13	23.4	21.8	19.3	18.7	19.3	19.6	16.4
12	20.7	21.6	18.3	18.8	19.5	18.3	16.1
11	20.0	20.5	19.2	19.6	20.2	18.4	18.5
10	21.3	21.2	21.9	22.2	24.3	21.8	22.7
9	24.4	24.8	26.8	27.5	30.0	26.9	27.3
8	29.8	30.2	33.1	33.6	36.9	33.6	33.9
7	37.1	38.0	40.8	40.7	44.3	41.2	41.2
6	43.3	45.0	47.9	47.8	51.4	48.8	49.4
5	49.8	52.0	54.8	54.8	58.1	55.6	56.2
4	55.7	58.4	61.0	61.7	64.3	61.9	62.9
3	61.3	64.0	66.9	67.7	69.8	67.6	69.2
2	66.7	70.3	71.7	73.2	74.5	73.0	75.1
1	271.0	275.3	276.8	278.0	278.5	277.6	280.7

The values are based on a comparatively large number of observations in each case, the smallest numbers being 31 and 29 for Petrograd and Scotland respectively, and the largest 167, for England, S.E.

The next table gives the temperature gradients for the same stations. The first thing noticeable from these tables is that at a certain height above the surface temperature ceases to fall. This

¹ Gold: *International Kite and Balloon Ascents*, M.O. Geophysical Memoirs, No. 5.

height is approximately constant for the same parallel of latitude, but varies with the latitude being greatest over the Equator and least over the Arctic regions. Below this level temperature falls with increase in height above the earth's surface, though the amount of decrease per kilometre is not exactly the same at all heights, the maximum value being found about 7 Km. Above and below this height the decrease per kilometre falls off slightly. Above the level where temperature ceases to fall there is practically no vertical temperature gradient, and when it is encountered, it has generally a small negative value.

TABLE XX
MEAN TEMPERATURE GRADIENTS

Height in Km.	Petrograd.	Scotland.	Berlin.	England, S.E.	Paris.	Vienna.	Pavia.
	Deg. A.	Deg. A.	Deg. A.	Deg. A.	Deg. A.	Deg. A.	Deg. A.
13.5	-0.1	-0.2	0.6	-0.2	0.2	0.0	-1.3
12.5	-2.7	-0.2	-1.0	0.1	0.2	-1.3	-0.3
11.5	-0.3	-1.1	0.9	0.8	0.7	0.1	2.4
10.5	1.3	0.7	2.7	2.6	4.1	3.4	4.2
9.5	3.1	3.3	4.9	5.3	5.7	5.1	4.6
8.5	5.4	5.4	6.3	6.1	6.9	6.7	6.6
7.5	7.3	7.8	7.7	7.1	7.4	7.6	7.3
6.5	6.2	7.0	7.1	7.1	7.1	7.6	8.2
5.5	6.5	7.0	6.9	7.0	6.7	6.8	6.8
4.5	5.9	6.4	6.2	6.9	6.2	6.3	6.7
3.5	5.6	5.6	5.9	6.0	5.5	5.7	5.9
2.5	5.4	5.7	4.8	5.5	4.7	5.4	6.3
1.5	4.3	5.0	5.1	4.8	4.0	4.6	5.6

Teisserenc de Bort was the first to discover this isothermal region, he having first noticed it in June, 1899, and again in March 1902. He found that the average height of its under-surface above the earth was about 11 Km., and later observations, from which Table XIX is compiled, agree with this value for mean latitudes. The table of temperature gradients indicates that the temperature gradient is greatest between 6 and 8 Km.; at 9 Km. it begins to fall off, and it ceases between 11 and 12 Km. In any individual sounding this gradual diminution is not generally met with. The decrease in temperature almost invariably ends abruptly, often an inversion of temperature occurring where the decrease stops. The reason for the apparent gradual diminution is that the values are mean values,

and the height at which each individual sounding shows the cessation of temperature-fall is not constant, but varies from 8 to 13 Km. Thus the mean values show a gradual decrease in the region of the dividing line.

As there is no vertical temperature gradient in the isothermal layer there can be no vertical convection, and in consequence the behaviour of the air masses in the two regions is entirely different. Several names have been suggested for the two regions, but those now commonly adopted are (1) the Stratosphere, denoting the region of no vertical convection, and (2) the Troposphere, denoting the region of vertical convection.

Annual Variation of Temperature.—The number of observations hitherto made with ballons-sondes is comparatively small, so that great accuracy is not yet possible in the values showing the annual variation of temperature. An approximation to the true value for any month in which there are but few observations may be arrived at by taking into consideration not only the records obtained for that month, but also those belonging to the two months, the one preceding and the other following the month under investigation. By adopting such a method, it is found that the annual range of temperature extends from the surface up to 8 or 9 Km. with but slight variation. Above this the range decreases, and from 12 Km. upwards it is only about half the surface value. There is a difference between continental and coastal climates, the former giving a maximum range at the surface, the latter at 7 Km. above the surface.

Diurnal Variation of Temperature.—If the information available for determining the annual range is small, that for determining the diurnal is much more meagre. Two series of observations extending over twenty-four hours each, carried out at Manchester, have already been referred to, and the number of records recovered from both series was large. But until a large number of such ascents is carried out, only approximate values can be given. From the information available, it appears that the diurnal variation of temperature as known at the surface disappears altogether between 1000 and 2000 m. Gold finds for the Berlin values an amplitude of 0.85° C. at 1000 m. Observations at Drexel in United States of America show an amplitude of 0.7° C. up to 3000 m. These numbers, however, are very small, and thus it is certain that if any range does occur above 2000 m. it is very small.

H_c, the Height of the Troposphere.—The height at which the temperature ceases to fall varies with latitude. It also varies with the seasons, being less in winter than in summer. Further, over a cyclone it is less than over an anticyclone. The thickness of the troposphere is generally denoted by H_c, and the term “tropopause” has been suggested to denote the place where the vertical temperature gradient ceases.

Generally the dividing line between the two regions, the troposphere and the stratosphere, is quite definite, but not invariably so, and in consequence the Meteorological Office has given the following instructions for defining the value of H_c:

“1°.—When the stratosphere commences with an inversion, H_c is the height of the first point of zero temperature gradient.

“2°.—When the stratosphere begins with an abrupt transition to a temperature gradient below 2° C. per kilometre without inversion, H_c is the height of the abrupt transition.

“3°.—Where there is no such abrupt change of temperature gradient, the base of the stratosphere is to be taken where the mean fall of temperature for the kilometre next above is 2° C. or less, provided that it does not exceed 2° C. for any subsequent kilometre.”

The variation in H_c due to latitude may be seen from the following figures:

Scotland 9.8 Km.	Petrograd 9.7 Km.
Manchester ...	10.3 „	Berlin ...	10.4 „
England, S.E. ...	10.7 „	Italy ...	11.0 „

Within the stratosphere in mean latitudes the difference in temperature between 14 and 20 Km. is less than 1° A. for average values, a fact which indicates at once that the temperature distribution is entirely different from that in the troposphere. The distribution of temperature in the troposphere and also in the stratosphere is represented in the coloured diagram, Plate XII. The different tints represent temperatures within certain limits, as indicated by the scale of tints, so that there are no abrupt changes in temperature corresponding to the abrupt change from one shade to the next. In the stratosphere the temperature decreases from the Pole to the Equator in a direction parallel to the earth's surface. In the troposphere the direction of decrease of temperature is perpendicular to the earth's surface. The portion of

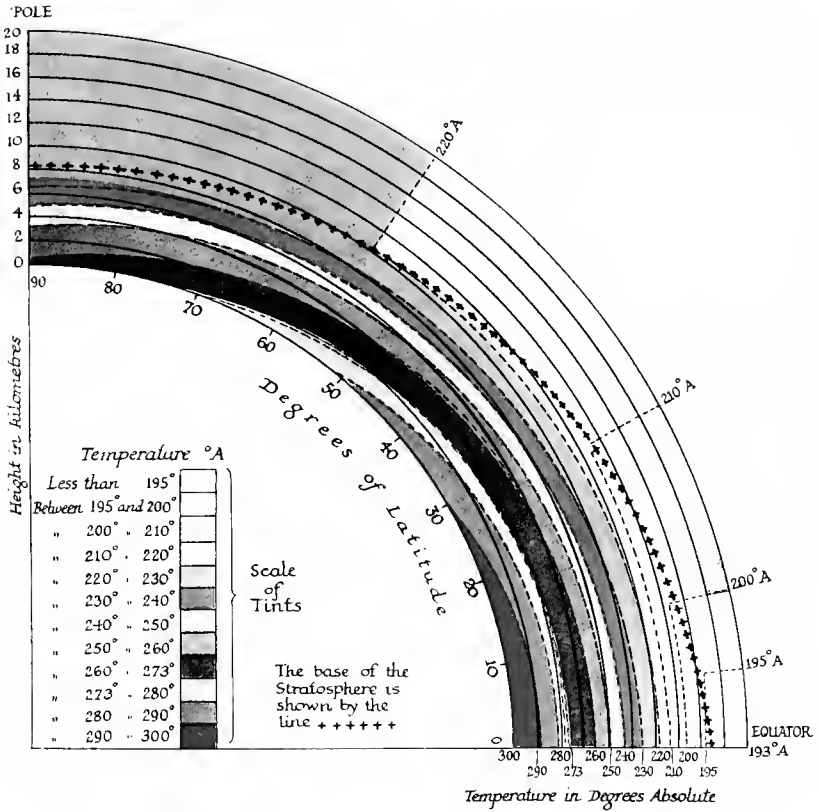

Diagrammatic Representation of the vertical distribution of air temperature

The Diagram shows the relatively small layer of air with a temperature above freezing-point (273° A.) that surrounds the earth in a belt

the atmosphere where the mean temperature is 273° A. and over is comparatively small, but as air is denser near the surface than at great heights, this mass is greater than the diagram appears to indicate. The base of the stratosphere is represented by the line of crosses. Data concerning the height of the base above the surface are at present limited, and in consequence it has been represented as a smooth curve. Over the Equator the height is more than double what it is over the poles

MEAN PRESSURE AND PRESSURE GRADIENTS

The method whereby the heights corresponding with the pressure values obtained from a meteorograph record are calculated, has been considered earlier in this chapter. In this method the value of the mean temperature in each layer is required, so that if the pressure at the top of this layer be p and at the bottom p_0 , while T is the mean temperature, then the thickness of the layer in kilometres is got from the relation

$$h = .06740 T \log \left(\frac{p_0}{p} \right).$$

If instead of the pressures, the values of h and T be known, the values of the pressures corresponding can be determined, and so in this way the mean pressures can be obtained from the mean temperatures given in Table XIX. The differences in pressure per kilometre increase slightly with latitude, as may be seen from Table XXI, up to 6 or 7 Km., and the differences are large. The variation of pressure difference between 2 and 10 Km. is comparatively small, however, for at the Equator the mean values for these heights are 803 mb. and 283 mb. respectively, and at Petrograd the corresponding values are 787 and 255 mb., the falls being 520 mb. and 532 mb. respectively. Above 12 Km. the pressure differences fall off rapidly, and also the decrease over the Equator is now greater than in higher latitudes. As a result the pressure at 20 Km. is practically uniform over the whole globe. The following table gives the mean values of the pressures up to 20 Km. for a number of stations arranged according to latitude. The values are those given by Dines.

The Paris values, it will be observed, differ slightly at all heights from the others. This, as Dines suggests, is probably due to the larger type of balloon used. For there is always some

TABLE XXI
MEAN PRESSURES

Height in Km.	Petrograd.	Scotland.	Berlin.	England, S.E.	Paris.	Vienna.	Pavia.	Equator.
20	55.0	55.0	54.8	54.9	56.0	55.0	54.8	53
19	64.0	64.2	64.0	64.1	65.6	64.4	64.0	63
18	74.5	74.8	74.8	75.0	76.6	75.2	75.0	75
17	87.0	87.3	87.4	87.5	89.6	88.0	87.6	90
16	101	102	103	102	105	103	103	107
15	118	118	120	120	123	121	121	128
14	138	138	140	140	143	142	142	152
13	161	161	164	164	167	165	165	178
12	187	187	192	192	195	193	194	209
11	218	219	225	224	228	226	227	244
10	255	256	262	261	266	263	264	283
9	297	299	305	303	309	306	307	327
8	346	348	354	352	357	354	356	376
7	400	402	408	407	412	409	412	430
6	461	464	470	469	473	471	474	491
5	529	532	538	538	541	539	542	558
4	606	608	614	615	617	615	618	632
3	692	694	699	699	701	700	703	713
2	787	787	795	795	796	795	797	803
1	896	894	900	900	900	900	901	903

The values are expressed in millibars.

heated air in the wake of the balloon as the balloon becomes heated by the solar radiation, and so the larger the balloon, the higher the temperature at any definite distance below the balloon. If the mean temperature of the underlying air-layers be 1° A. too high, then this would cause a difference of .6 mb. in the calculated pressure for 20 Km. This is of the order of difference between the Paris results and the other results, so that Dines' suggestion affords a satisfactory explanation of the apparent discrepancies.

Annual Variation of Pressure.—The values given in Table XXI are mean values. If instead of these the values for the individual months be taken, then it is found that there is an annual variation of pressure, the maximum occurring in summer and the minimum in winter. The variation extends all the way up through the atmosphere, and the range is almost the same at 2 Km. as at 14 Km., being about 11 mb. at both heights. It rises to a maximum of about 18 mb. between 7 Km. and 8 Km. Above

14 Km. it decreases farther, and at 20 Km. the annual range is probably about 5 mb.

Though the range at 2 Km. and 14 Km. is almost the same, yet the variation regarded as a percentage of the mean pressure is very much greater at the latter height than at the former, for the mean pressure at 2 Km. is more than $5\frac{1}{2}$ times that at 14 Km.

MEAN DENSITIES.

From a knowledge of the mean pressures and temperatures it is an easy matter to calculate the mean densities at all heights to a first approximation at all events. For if the water vapour in the atmosphere be neglected and also the variation of g with height, then the quantities are connected by the relation $p = R \rho T$, where p is the pressure, T the absolute temperature, and R a constant. As the quantity of water vapour in the atmosphere is small and mainly confined to the lower layers, the values obtained by the above method do not differ greatly from the true values.

PRESSURES AND TEMPERATURES IN CYCLONES AND ANTICYCLONES

According to the old theories of cyclones and anticyclones, the temperature of the air within a cyclone was regarded as being higher than that within an anticyclone. But when observations of temperature began to be made in the free atmosphere, it soon became apparent that the explanations hitherto given of the formations of cyclones and anticyclones of mean latitudes would have to be abandoned, or at least considerably modified. The following table shows the average temperatures and pressures within cyclones and anticyclones up to 14 Km.

The mean value of H_c for the cyclone is 8.7 Km. and for the anticyclone 12.3 Km., giving a difference of 3.6 Km.

So when a cyclone approaches an area, both temperature and pressure decrease from the surface up to 9 Km., while the temperature of the air from 11 Km. to 20 Km. rises or remains nearly constant. At 20 Km. pressure is practically uniform over both cyclones and anticyclones, and thus a cyclone remains a cyclone up to 20 Km., and an anticyclone remains an anticyclone to the same height. But from 2 Km. to 9 Km. the *pressure differences* fall off only slightly, whereas above this height they fall off rapidly.

TABLE XXII

MEAN PRESSURES AND TEMPERATURES IN CYCLONES AND ANTICYCLONES

Height in Km.	Cyclone = 989 mb.		Anticyclone = 1026 mb.		Temperature Difference.
	Temperature.	Pressure.	Temperature.	Pressure.	
14	224° A.	135 mb.	215° A.	143 mb.	+ 9° A.
13	25	158	15	168	+ 10
12	25	184	17	197	+ 8
11	24	214	20	231	+ 4
10	25	249	25	269	0
9	26	289	31	313	- 5
8	28	337	38	362	- 10
7	34	390	46	417	- 12
6	42	451	53	478	- 11
5	49	519	59	547	- 10
4	56	594	65	623	- 9
3	63	678	71	708	- 8
2	70	772	76	802	- 6
1	276	875	279	908	- 3

This table is represented diagrammatically in fig. 83. There the temperature values have been extended up to 20 Km. on the assumption that temperature within the stratosphere remains constant in a vertical direction.

The Cause of the Temperature Difference.—The question then arises how this difference in temperature between the cyclone and the anticyclone comes about. Evidently it can only be due to dynamic heating and cooling, for radiation cannot account for it, as the amount of solar radiation received at the outer limits of the atmosphere is not sufficient to raise the temperature of the atmosphere 3° A., much less to cause a difference of 10° A. or more per day, which is often found to take place with changing conditions of pressure. For changes which take place adiabatically we have $pv^\gamma = c$, where γ is the ratio of the specific heats of air and is equal to 1.4. Also $pv = RT$, and so

$$v^\gamma = R^\gamma T^\gamma / p^\gamma$$

$$\text{or } p^{\gamma-1} = AT^\gamma ;$$

$$\text{i.e. } (\gamma - 1) \frac{\delta p}{p} = \gamma \frac{\delta T}{T},$$

$$\text{i.e. } \frac{\delta T}{T} = .29 \frac{\delta p}{p}.$$

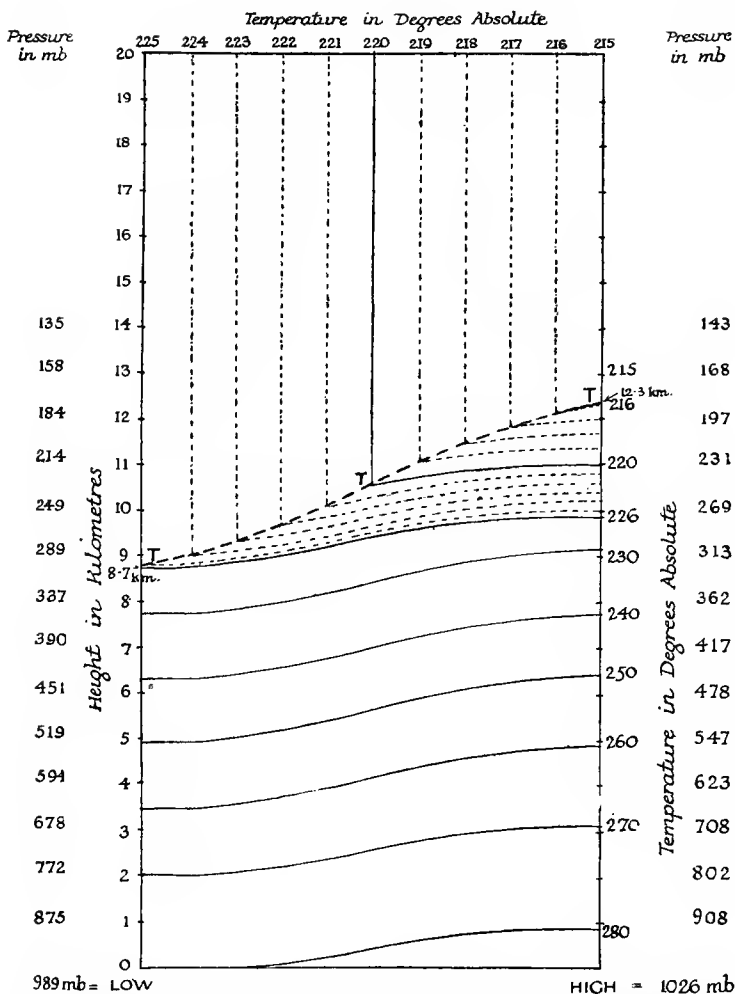

Fig. 83.—Diagram showing vertical distribution of temperature in the troposphere over centres of high and low pressure: also horizontal slope of temperature in the stratosphere from over a low centre to above a high centre. The base of the stratosphere is shown by the line TTT. (According to data quoted by W. H. Dines in *Characteristics of the Free Atmosphere*.)

By taking the mean values of T and p and calling $\delta p = 1$ mb., we find the corresponding changes in temperature to be:

Ht.	0	2	4	6	8	10	12	14	16	18	20
δT	.08	.10	.12	.15	.19	.25	.33	.45	.65	.85	1.15° A.

If the pressure differences indicated in Table XXII be used, the changes in temperature due to adiabatic change alone would be:

Ht.	0	2	4	6	8	10	12	14 Km.
	3.0	3.0	3.5	4.0	4.7	5.0	4.3	3.6° A.

Thus part of the temperature difference shown in Table XXII is accounted for in the lower layers, but in the upper layers the differences are accentuated, and therefore the temperature differences must be mainly due to vertical motion. If no water vapour were present, the difference for a rise of 1 Km. would be nearly 10° A., and so, using the gradients given in Table XX, we see that the differences between 10° and the numbers given indicate the number of degrees that air rising 1 Km. will find itself below the mean temperature of the new position. The height that air must rise in passing from an anticyclone to a cyclone below the troposphere, and the distance through which it must fall above the troposphere, can therefore be easily calculated. The currents at the surface flowing in towards the centre of a cyclone show that there is an upward component of velocity near the surface, but, says Dines, it is rather difficult to see how the cold heavy air, which one would expect to be falling, is forced upwards.

The Law of the Temperature Difference. — Shaw in his *Principia Atmospherica* has shown that at 9 Km. above the surface the wind blows horizontally, that no mass of air passes from the troposphere to the stratosphere, and consequently that no mixing of the air in the two regions takes place. Also if the methods of correlation be applied, it is found that the correlation coefficients between T_c , the temperature at the tropo-pause (and thus virtually the temperature of the stratosphere over the point considered), and the quantities p_o , p_s , T_m , are all large and negative, so that it necessarily follows that the law is that where the upper strata are warm, the lower strata are cold and vice versa. This is bound to follow from the uniformity of pressure at 20 Km., for this uniformity of pressure depends almost entirely on the mean temperature of the air from the surface to 20 Km. The mean temperature, therefore, must be the same, not only for cyclones and anticyclones of mean latitudes, but also for all parts of the globe, so that the temperature in the stratosphere over the Equator must be very much lower than in high latitudes, which is in agreement with observation.

Connection between Pressure and Temperature. — The close connection between pressure and temperature in cyclones and anticyclones is at once evident when the methods of correlation are applied. Between the surface pressure and surface temperature there is but little connection, but between the surface pressure and the temperatures at the other heights there is a comparatively close relation, and also between the various pressures and temperatures from 1 Km. to 9 Km.; but the closest connection is found between the pressure at 9 Km. and the mean temperature T_m , the value of the correlation coefficient being .95. There is also a close connection between the surface pressure and the pressure at 9 Km., indicating that the conditions at the surface are apparently dominated by the pressure at 9 Km.

Dines has been able to show further that the height H_c is also almost entirely dependent on the pressure at 9 Km., the mean temperature of the atmosphere playing but a small part. Thus if the pressure at 9 Km. is high, then H_c is large, if the 9 Km. pressure is low, then H_c is small.

The following table serves as an example of the values of some correlation coefficients as determined by Dines.

TABLE XXIII
CORRELATION COEFFICIENTS

	T_0 and P_0 .	T_1 and P_1 .	T_2 and P_2 .	T_3 and P_3 .	T_4 and P_4 .	T_5 and P_5 .	T_6 and P_6 .	T_7 and P_7 .	T_8 and P_8 .	T_9 and P_9 .	T_{10} and P_{10} .	T_{11} and P_{11} .	T_{12} and P_{12} .	T_{13} and P_{13} .
Jan.-Mar.	-.02	.54	.82	.79	.86	.85	.84	.87	.91	.81	.35	-.32	-.38	-.37
Apr.-June	.14	.28	.49	.79	.89	.89	.92	.87	.81	.45	.20	-.12	-.24	-.01
July-Sept.	-.02	.31	.56	.72	.75	.81	.83	.87	.87	.88	.43	-.08	-.41	-.19
Oct.-Dec.	.33	.56	.76	.77	.83	.87	.85	.85	.86	.78	.29	-.24	-.34	-.50
Mean	.11	.42	.66	.77	.84	.85	.86	.86	.86	.71	.32	-.19	-.36	-.28

Also P_9 and T_0 .28 $T_{.5}$.60 T_1 .68 $T_{1.5}$.73 T_2 .74 T_3 .82 T_5 .82

	P_0	P_9	T_m	H_c	T_c	T_0
P_068	.47	.68	-.52	.16
P_9	.6895	.84	-.47	.28
T_m	.47	.9579	-.37	...
H_c	.68	.84	.79	...	-.68	.30
T_c	-.52	-.47	-.37	-.68
T_0	.16	.2830

Here T_0, T_1, \dots and P_0, P_1, \dots represent the temperatures and pressures at the surface, 1 Km. above the surface... T_m is the mean temperature of the air up to 20 Km. H_t is the height of the tropopause and T the temperature at that height.

WIND VELOCITY AND DIRECTION IN THE FREE ATMOSPHERE

The wind velocity in the free atmosphere can be recorded by an anemometer, attached to a kite, in the various layers through which the kite rises. The anemometer used in such cases generally forms part of the baro-thermo-hygro-anemograph already referred to. These anemometers are of the Robinson type inverted, and measure the total mileage run during the time the kite is in the air. The wind direction in the different layers can be obtained from the direction of the wire at the ground, as the kite remains in each layer sufficiently long to permit of the direction in the layer being determined.

Similar methods can be adopted with a captive balloon. The anemometer, which may be either of the Robinson type or of the type possessing a propeller with light blades, as in the air-meter, can be lowered by the observer sufficiently far below the basket of the balloon to be free from eddy currents caused by the balloon. An electrical connection enables a bell to be rung after a given number of revolutions, thereby enabling the observer to determine the distance passed over in a given time, the instrument having been previously calibrated in a wind channel. As with the kite, the direction of the wind is determined from the direction of the wire at the ground.

But the range of the kite and also of the captive balloon is very limited, and it is impossible to get wind data above 4 or 5 Km. by this method. The usual method of obtaining wind data in the free atmosphere is to observe the ascent by means of theodolites, of a ballon-sonde, or more commonly, of a pilot balloon. The position of the balloon is determined after definite intervals of time, and so both the velocity and the direction of the wind can be found in any layer. As the position of the balloon is determined, its height above the surface is known, and therefore the pressure as given on the meteorograph record can be read off directly. This is the only direct method of obtaining the pressure at the different levels.

Methods of Observation.—A very complete account of the methods of observing by balloons-sondes and pilot balloons has been given by Cave in his *Structure of the Atmosphere in Clear Weather*. The following short description will enable the reader to understand how some of the observations are carried out.

METHODS OF OBSERVATION OF PILOT BALLOONS

Two-Theodolite Method.—In this method two theodolites are employed, one at each end of a base line. The type of theodolite used is shown in Plate XIII. The horizontal circle enables the

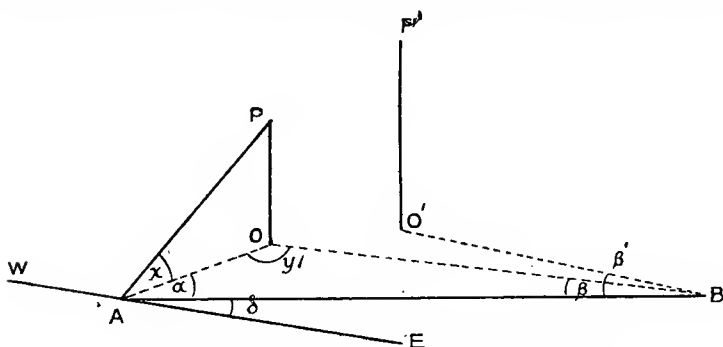

Fig. 85.—Diagram showing Method of Calculation of Balloon Ascent

azimuth of the balloon to be determined, and the vertical circle, the elevation or altitude. Readings of azimuth and altitude are taken at the end of each minute, and the path determined from the readings in the following way.

Let A and B , fig. 85, be the ends of a suitable base line. This line should be chosen in such a way that the direction of motion of the lower or intermediate clouds is perpendicular to the line. By this means the balloon travels in a direction more or less perpendicular to the base, at least until considerable heights are reached. The angles subtended at A and B are thus both fairly large, and both less than 90° , so that the third angle of the triangle is also of reasonable dimensions. Communication is established between A and B by telephone or by morse signalling. When the theodolites have been levelled and adjusted for the meridian, then the bearing of the one station with regard to the other is determined. Also if the two stations are not at the

same height above the sea-level, the elevation of the one above the other is read on the vertical circle of the theodolite.

If wind data only are required, a pilot balloon, of which an example is also shown in fig. 84, Plate XIII, alone is required. The balloon is a small rubber balloon filled with hydrogen and from 18 in. to 20 in. diameter when inflated. The weight of the balloon when empty is about 12 grm., and when inflated the free lift should be about 60 grm.

For the sake of simplicity let us suppose that A and B are on the same horizontal plane. The end A we will term the "home" station, and the end B the "field" station. From the end B the balloon is released at a given instant by an observer as indicated in fig. 84, and then observations of azimuth and altitude are made at both stations simultaneously at the end of each minute. As considerable irregularities often exist quite close to the surface, a reading should be taken whenever possible at the end of the first half-minute.

Calculation of Results of Observation.—In fig. 85 let P be the position of the balloon at the end of the first minute and O the foot of the perpendicular drawn from P on the plane AOB. Then if α and β be the azimuths of the point P, and χ the altitude with regard to A, in the Δ AOB since α and β are known,

$$\therefore \angle AOB = 180 - (\alpha + \beta) = \gamma \text{ (say);}$$

also

$$\frac{AO}{AB} = \frac{\sin \beta}{\sin \gamma} \quad \text{i.e. } AO = AB \frac{\sin \beta}{\sin \gamma} \text{, which determines } AO.$$

Now AO is the horizontal distance gone in the first minute, and so if AO be measured in metres, the average horizontal velocity in metres per second in the layer through which the balloon has passed can be obtained by dividing AO by 60.

If, instead of the actual velocities, the component velocities in two directions perpendicular to one another be desired, this can easily be obtained. For if δ be the angle between the direction AB and the west-east line, then the angle between AO and W.E. is $(\alpha + \delta)$, and the components of AO along and perpendicular to W.E. are $AO \cos (\alpha + \delta)$ and $AO \sin (\alpha + \delta)$. Hence the component velocities in metres per second can be determined.

Again in Δ AOP, $\frac{OP}{OA} = \tan \chi$, and $\therefore OP = OA \tan \chi$, i.e. the height of P above the horizontal plane through A is



Fig. 84.—Theodolite and Pilot Balloon

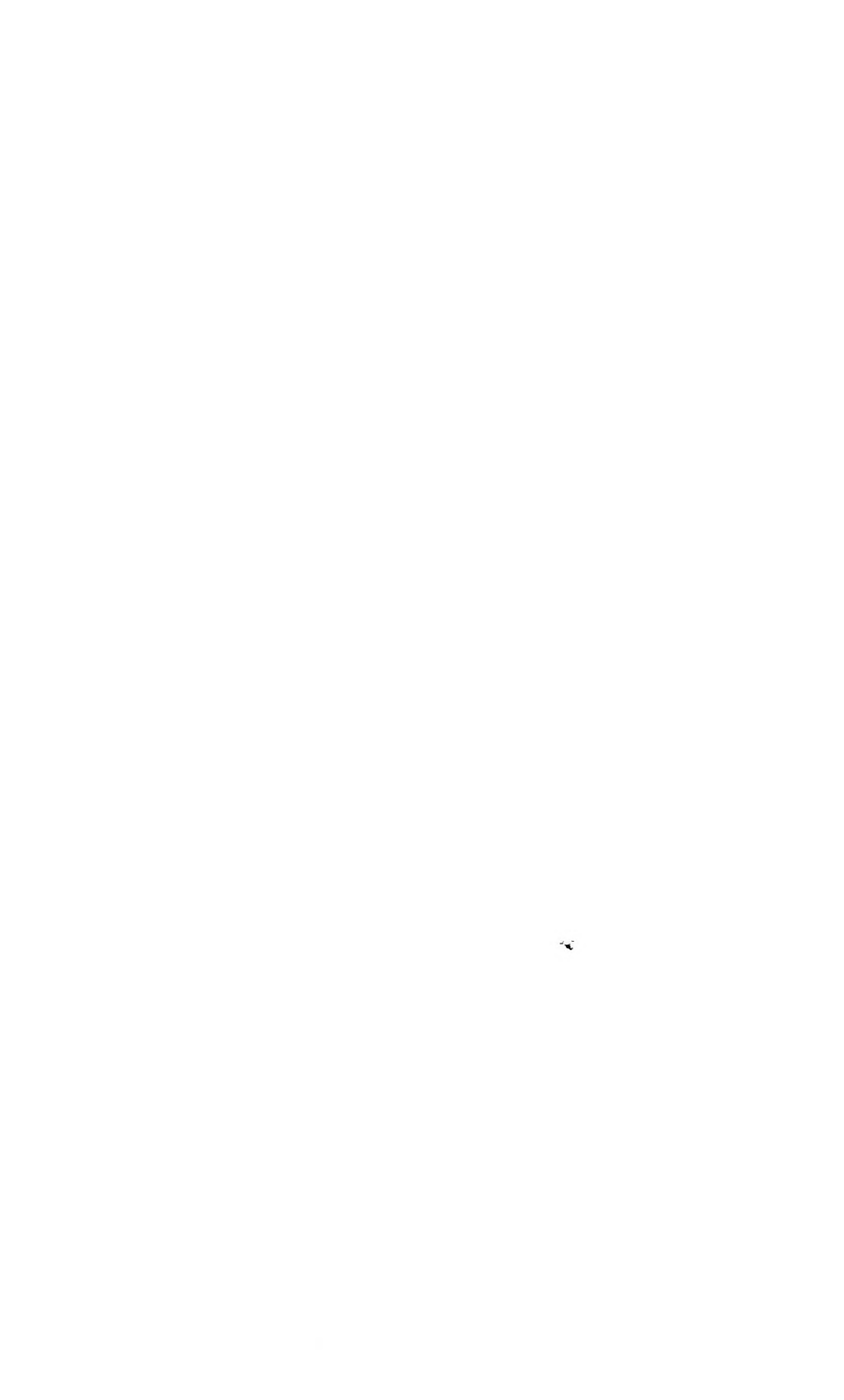

determined. The distance OP divided by 60 will give the average rate of ascent in metres per second for the layer up to the level of P.

At the end of the second minute the balloon has come to the point P' vertically above O' in the plane through A. Let the azimuth angles and the altitude from A be now α' , β' , and χ' .

Then as before $AO' = AB \frac{\sin \beta'}{\sin \gamma'}$ and $O'P' = OA' \tan \chi'$.

Thus the vertical velocity during the second minute in metres per second is given by $(O'P' - OP)/60$.

The components of AO' are:

$$\begin{aligned} \text{W.E. component} &= AO' \cos(\alpha' + \delta), \\ \text{S.N. component} &= AO' \sin(\alpha' + \delta); \end{aligned}$$

therefore the components of the horizontal velocity during the second minute are, in metres per second:

$$\begin{aligned} \text{W.E. component} &= \frac{AO' \cos(\alpha' + \delta) - AO \cos(\alpha + \delta)}{60} = W, \\ \text{and S.N. component} &= \frac{AO' \sin(\alpha' + \delta) - AO \sin(\alpha + \delta)}{60} = S. \end{aligned}$$

By combining these two quantities, the direction of motion and the resultant velocity in metres per second during the second minute can be found; for if R is this resultant velocity, then

$$R = \sqrt{W_1^2 + S_1^2};$$

and if θ is the angle between the direction of motion and the W.E. line, then $\tan \theta = S_1/W_1$, and also $R = S_1 \sin \theta = W_1 \cos \theta$.

The same process can be applied to the 2nd, 3rd,nth minutes, and therefore the horizontal and vertical velocities can be determined accurately at any point on the path, and likewise the direction of motion.

It will be observed that use has been made of the altitude readings of one station only. In practice it is well to read both altitudes so that a check can be put on the work at any point, and any doubtful reading verified. Also it may happen that a reading is missed at one station on account of clouds, and values may therefore have to be calculated from the readings taken at the other station.

The One-Theodolite Method.—Where two theodolites are employed, the calculations are very laborious, and for most pur-

poses for which wind values in the upper air are required, sufficient accuracy can be obtained by using one theodolite. A base line and a field station are no longer required, the balloon being released and the observations made from the home station.

Rate of Ascent Assumed.—In this method, however, the vertical velocity has to be assumed. The two-theodolite method has shown that the rate of ascent for any particular flight is nearly uniform, especially after the balloon is beyond the disturbing influence of objects on the earth's surface. This vertical velocity can be expressed in the form:

$$V = \frac{Q}{60} \cdot \frac{L^{\frac{1}{2}}}{(W + L)^{\frac{1}{2}}} \text{ metres per second,}$$

where L is the free lift of the balloon in grammes, and W its weight before inflation. From experiments carried out at South Farnborough in 1911, J. S. Dines found that the constant Q in still air has a value 81.¹ If there are considerable convection currents, then these tend to raise the balloon at a greater velocity, and therefore attention ought to be paid during any particular flight to the general condition of the atmosphere at the time. The effect of convection currents will be seen from the vertical velocities in the following example where two theodolites were used. These velocities were as follows:

Height in kilometres	0.5	1.0	1.5
Velocity in metres per second	5.7	5.2	6.2. ²

The vertical velocity calculated from the formula is 2.4 m. per second, but the sounding was carried out at 11 h. on 10th May, 1912, at a time when cumulus cloud was forming rapidly and convection very active.

The downward current behind a squall can also be seen from velocities obtained with two theodolites from a balloon released as a squall burst over the home station at Aberdeen on 12th December, 1913.²

Height in kilometres	.25	.35	.5	.75
Velocity in metres per second	1.8	0.6	2.0	2.2

In addition to these variations, Q also appears to vary slightly

¹ Later experiments give a value of 84 for Q in southern England.

² Geddes: *Quar. Jour. Roy. Met. Soc.*, Vol. XLI, p. 129.

with the situation of a station. For Aberdeen the average value of Q is nearer 90 than 81.

Calculations from One-Theodolite Readings.—By assuming the vertical velocities, however, we assume the heights OP , $O'P'$, in fig. 85, and as we read the angles χ , χ' , on the altitude circle of the theodolite, the distances OA , $O'A$, are at once found from the relations, $OA = OP \cot \chi$, $O'A = O'P' \cot \chi'$, The azimuth angles α , α' , give the azimuths of the points P , P' from the S.N. or the W.E. line. Suppose that these angles are the angles made with the W.E. line, then the components are given by

$$\begin{aligned} \text{W.E.} &= AO \cos \alpha, AO' \cos \alpha' \text{} \\ \text{S.N.} &= AO \sin \alpha, AO' \sin \alpha' \text{} \end{aligned}$$

From these values the component velocities in a horizontal direction for any minute can be calculated, and thence the resultant velocity and the direction of motion in exactly the same way as in the other method.

$$\text{For } \tan \theta = S/W \text{ and } R = S \sin \theta = W \cos \theta, \text{ \&c.}$$

This method is very suitable for the calculations being carried out by slide-rule. The distances $OP \cot \chi$, can be read off at once from the tangent scale, and then the angles α , being known, the components $AO \cos \alpha$, , $AO \sin \alpha$, are obtained from the sine scale. The differences between these values are found by subtraction, and with these minute values the various values of θ are arrived at, from which the resultant velocity at once follows by the relation $R = S \sin \theta$, All these manipulations can be carried out by means of the slide-rule, with the exception of the subtractions.

The resultant velocity and the direction may be obtained even more expeditiously from the components by using a table such as is indicated in fig. 86, than by the use of the slide-rule.

The Tail Method.—A third method of observing is the tail method. Two balloons are tied together by a piece of string of known length, and one balloon having a greater free lift than the other, the string between them is vertical. By means of a moveable cross wire within the eye-piece of the telescope, the angle subtended by this constant length of string can be read, and so the distance of the balloons determined.

Methods Compared.—The two-theodolite method gives the greater accuracy in determining the velocities near the surface. In the lower layers the vertical velocities are by no means so constant as they are in the layers where the surface influences are much less. But at great heights and at great distances from the point of origin, the one-theodolite method is perhaps better than the double-theodo-

		Component velocity in metres per second								
		1	2	3	4	5	6	7	8	
Component velocity in metres per second	1	45 1.4	27 2.2	18 3.2	14 4.1	11 5.1	9 6.1	8 7.1	7 8.1	-----
	2	45 2.8	34 3.6	27 4.5	22 5.4	18 6.3	16 7.3	14 8.2	-----	
		3	45 4.2	37 5.0	31 5.8	27 6.7	23 7.6	21 8.5	-----	
	4		45 5.6	39 6.4	34 7.2	30 8.1	27 8.9	-----		
		5	45 7.1	40 7.8	36 8.6	32 9.4	-----			
	6		45 8.5	41 9.2	37 10.0	-----				
		7	45 9.9	41 10.6	-----					
	8		45 11.3	-----						

Fig. 86.—Calculating Table

Resultant direction in degrees in small type. Resultant velocity in metres per second in large type.

lite method. For as the base line must be comparatively small, then when the balloon is distant from the origin several times the base length, the angle subtended by the base at the balloon is very small. Consequently, if even a small error of a few minutes be made in reading the azimuth angles, a considerable error may be introduced in calculating the horizontal distance of the balloon. More accurate values will therefore be obtained by using one theodolite and assuming the vertical velocity at great distances.

SOME RESULTS OF OBSERVATION

From observations of the wind in the free atmosphere, carried out by the aid of pilot balloons and ballons-sondes, it has been found that the velocity of the wind at a height of from 300 to 500 m. above the surface approaches closely to that of the gradient wind. Above this height the general tendency is for the wind to surpass the gradient velocity except in easterly winds. The gradient velocity is reached rather sooner than the gradient direction, which on an average is not attained until 800 or 1000 m. above the surface. Higher up the wind direction tends to depart more and more from the direction of the gradient wind.

Cave's Analysis.—An analysis of results obtained from ascents of pilot balloons and ballons-sondes has been carried out by Captain C. J. P. Cave,¹ and he has classified his observations into the six following groups, five groups for winds within the troposphere, and one for winds in the stratosphere:

- (a) 1. "Solid" current; little change in velocity or direction.
2. No current up to great heights.
- (b) Considerable increase in velocity.
- (c) Decrease of velocity in the upper layers.
- (d) Reversals or great changes in direction.
- (e) Upper wind blowing outward from centres of low pressure; frequently reversals at a lower layer.
- (f) Winds in the stratosphere.

In the first group, "solid" currents, the gradient direction and velocity are reached quite early. Beyond this height both velocity and direction are nearly constant, so that the distribution of pressure in the upper layers must be similar to that at the surface. In general also there exists at the time of the observation practically no temperature gradient over the area. Cases where no current is met with up to great heights occur mainly near the centre of anti-cyclones.

Group (b), where the velocity increases considerably with height, and where there is also a tendency for the wind to veer with height, is associated with a marked temperature gradient over the area. Such winds occur when a cyclone is situated to the north or west of the observing station, and would therefore seem to represent the normal conditions when depressions are passing eastwards across the north of the British Isles.

¹ Cave: *Structure of the Atmosphere in Clear Weather*, 1912.

His third group (*c*) deals with winds, which, after reaching the gradient velocity at about 500 m., decrease with further increase in height. These winds are practically confined to easterly winds, and the distribution of pressure in such cases shows an anticyclone to the north, with a low-pressure centre to the south. The gradient direction is generally reached a little above the point of maximum velocity, and thereafter the wind often backs towards north-east or north, though not invariably so, the easterly current persisting at times to great heights.

In group (*d*) are given "reversals". "The explanation of the reversal", says Cave, "is not always easy to determine, and probably different causes are at work in different instances." The surface wind in this group is almost always an easterly wind, and the upper wind a westerly or south-westerly. We have, therefore, a warm current passing over the top of a denser easterly current, and such a condition is generally followed by rain. In summer-time a surface south-easterly and an upper south-westerly current are very often associated with shallow thunderstorm depressions, the moist south-west current supplying the water vapour for the formation of the cumulonimbus.

Winds blowing out from the centres of low-pressure areas are dealt with in group (*e*), and a large number of individual cases are considered. In nearly all instances it is found that the depression from which the upper current is flowing out advances in the direction of the upper current. This is in agreement with Guilbert's rules with regard to the motion of cirrus and depression centres. Also if one considers these currents in the light of the method developed in the next section of this chapter, it is possible to see why these currents should arise from the difference of temperature in the different currents flowing round the various low-pressure centres. This is particularly the case with north-westerly upper winds. When the upper wind is south-westerly we have conditions very similar to those considered under group (*d*), and in this case thunderstorms very frequently follow, especially in the summer-time.

Group (*f*) deals with winds where the stratosphere was entered, and it was found in practically all cases that the maximum wind velocity was met with in the troposphere immediately below the base of the stratosphere. Within the stratosphere the wind velocity fell off, often quite rapidly. The direction of the wind within the stratosphere was also almost invariably from some point

on the west side of the south-north line, i.e. the air within the stratosphere up to at least 5 or 6 Km. above its base possessed a westerly component.

Cave has constructed a large number of models representing these various types of currents, which enable one to see at a glance how the currents change with height, both as regards velocity and direction. Models similar to these may be easily constructed by any teacher, and he is likely to find them of the greatest assistance in class demonstration.

DISTRIBUTION OF PRESSURE AND TEMPERATURE IN THE FREE ATMOSPHERE AS REVEALED BY PILOT BALLOON SOUNDINGS

In his *Principia Atmospherica* Shaw has developed a method of determining the pressure and temperature distributions in the free atmosphere from the observations of wind obtained by pilot balloons.

The relation for the geostrophic wind, as already established, is:

$$\gamma = 2\omega V D \sin \phi \text{ or } 2\omega V \rho \sin \phi,$$

where the symbols have their usual meanings. If the pressure at any point in the atmosphere is p , and that at another point on the same horizontal plane at a distance L , where L is measured in hundreds of kilometres say, is $p + \Delta p$, then the gradient between these two points can be written as $\Delta p/L$.

Also the characteristic gas equation is:

$$pv = RT, \text{ or, } p = R\rho T,$$

and therefore,

$$\Delta p/L = 2\omega V \frac{p}{RT} \sin \phi,$$

or

$$V = \frac{R}{2\omega \sin \phi} \cdot \frac{T}{p} \cdot \frac{\Delta p}{L} = K \frac{T}{p} \cdot \frac{\Delta p}{L},$$

where K is a constant for each separate latitude.

This enables the pressure differences at all levels to be calculated, provided the ratios p/T and the wind velocities are known. As it is often more useful to have the components of these pressure differences in two directions, the south-north and west-east components can be obtained directly from the wind components, for

$$V_{(WE)} = K \cdot \frac{T}{p} \cdot \frac{\Delta p_N}{L}, \text{ and } V_{(SN)} = K \cdot \frac{T}{p} \cdot \frac{\Delta p_W}{L},$$

where $V_{(WE)}$ and $V_{(SN)}$ are the components of the wind in a west-east and south-north direction respectively.

Then

$$\Delta p_N = \frac{1}{K} \cdot \frac{p}{T} V_{(WE)}, \text{ and } \Delta p_W = \frac{1}{K} \cdot \frac{p}{T} V_{(SN)},$$

where Δp_N and Δp_W are the pressure gradients per 100 Km. northwards and westwards respectively. These quantities are reckoned positive in the direction in which pressure is *decreasing*.

Having obtained the pressure differences, one can by their aid arrive at the temperature differences.

For

$$\begin{aligned} p &= R\rho T, \\ \therefore \frac{\Delta p}{p} &= \frac{\Delta \rho}{\rho} + \frac{\Delta T}{T}, \\ \text{i.e. } \Delta \rho &= \frac{p}{RT} \left(\frac{\Delta p}{p} - \frac{\Delta T}{T} \right). \end{aligned}$$

The decrease of pressure on ascending a height, δh , is

$$\begin{aligned} \delta p &= -g\rho\delta h \text{ over one position,} \\ \text{and } \delta(p + \Delta p) &= -g(\rho + \Delta\rho)\delta h \text{ over the other position,} \\ \therefore \delta(\Delta p) &= -g\Delta\rho\delta h = -\frac{g p}{RT} \left(\frac{\Delta p}{p} - \frac{\Delta T}{T} \right) \delta h \\ &= \frac{g p}{RT} \left(\frac{\Delta T}{T} - \frac{\Delta p}{p} \right) \delta h. \end{aligned}$$

If $\delta h = 1 \text{ m.},$

$$\delta(\Delta p) = .0342 \frac{p}{T} \left(\frac{\Delta T}{T} - \frac{\Delta p}{p} \right),$$

$$\begin{aligned} \text{i.e. } \frac{\Delta T}{T} &= \frac{\text{change in pressure difference per metre of height} + \frac{\Delta p}{p}}{.0342 \times \frac{p}{T}} \\ &= \frac{\text{change in pressure difference per kilometre of height} + \frac{\Delta p}{p}}{34.2 \frac{p}{T}} \end{aligned}$$

The following table is an example of the application of the method of determining the pressure and the temperature distributions in the free atmosphere. The observations were made at Aberdeen on 22nd, 25th, and 28th May, 1914, by the aid of one theodolite.

Pressure and Temperature Distributions deduced from the Observed Winds.—On the 22nd a strong south-west to west wind prevailed, which increased rapidly with height. The wind on the 28th was from nearly the same direction, but was much lighter. There was in both cases a slight tendency to veer with height. On

TABLE XXIV

COMPUTATION OF PRESSURE AND TEMPERATURE DISTRIBUTIONS FROM PILOT
BALLOON ASCENTS ON 22ND, 25TH, AND 28TH MAY, 1914

Height in Km.	Vel. m. p. s.	Direc- tion.	W.-E. Com- ponent.	S.-N. Com- ponent.	Δp_N .	Δp_W .	ΔT_N .	ΔT_W .	$\frac{100}{\Delta T_N}$.	$\frac{100}{\Delta T_W}$.
3	24.8	238°	+21.2	+13.1	+2.35	+1.45	+4.26	+3.56	+23	+28
2	10.4	250°	+10.0	+3.6	+1.24	+.45	-1.54	-1.90	-65	-53
1	16.4	238°	+14.2	+8.7	+1.96	+1.20	+3.07	+9.2	+32	+109
0	1.96	240°	+1.7	+1.0	+.98	+.98
8	12.8	316°	+8.8	-9.2	+.57	-.59	+.64	-1.79	+156	-56
7	8.3	299°	+7.1	-4.0	+.51	-.29	+.72	+.16	+139	+625
6	6.9	312°	+5.1	-4.6	+.41	-.37	+.53	-.54	+189	-185
5	4.8	310°	+3.7	-3.1	+.33	-.28	+.72	+.29	+139	+345
4	4.4	337°	+1.7	-4.0	+.17	-.40	+.82	+1.72	+122	+58
3	8.8	3°	-0.5	-8.8	-.06	-.98	+1.15	-3.21	+87	-31
2	3.6	90°	-3.6	+0.03	-.45	+.004	-2.70	-2.30	-37	-43
1	7.0	240°	+3.5	+6.1	+.48	+.84	+.55	+3.18	+182	+31
0	1.0	270°	+1.0	0.0	+.32	-.32
4	8.9	263°	+8.7	+1.1	+.87	+.11	+1.32	-1.18	+76	-85
3	7.0	231°	+5.3	+4.4	+.59	+.49	+.95	+1.96	+103	+51
2	2.9	288°	+2.8	-0.9	+.35	-.10	+.48	-.09	+208	-1111
1	1.7	291°	+1.6	-0.6	+.22	-.08	-.89	-.23	-112	-435
0	0.0	...	-0.0	+0.0	+.60	0.0

All velocities are in metres per second, pressure differences in millibars, and temperature differences in degrees Absolute.

The last two columns give the distance apart in kilometres of the 1° A. isotherms.

the 25th the wind up to 3.5 Km. was mainly light and variable, but above that height a definite north-westerly current was encountered, which increased with height and veered, passing definitely to north-west at 8 Km. On the previous day the current from the surface up to 3 Km. was between north and north-west.

Except at heights of 2 and 3 Km. on the 25th, all show a decrease of pressure towards the north, and this decrease increases with height. On the other hand, the west-east distribution varies much more from day to day. The temperature, like the pressure, indicates an almost regular decrease towards the north, but the west-east component is very irregular, even on the same day the variation from height to height being considerable. The difference in behaviour in the two directions is borne out well in the last two columns of the table. From over fifty observations taken during the year 1913-4 the results arrived at are similar. On the whole, therefore, these observations show a decrease of both pressure and

temperature towards the north, while the west-east distribution is irregular. Only in easterly types is an increase of pressure towards the north encountered. Occasionally in such types a decrease of temperature towards the north accompanies an increase of pressure, but such cases are rare. As a result of these observations it appears that the west-east isobars and isotherms in the free atmosphere are comparatively regular, and tend to follow or lie parallel to one another, but that the south-north isobars and isotherms are very irregular, and often are in the opposite sense. An examination of the pressure distribution at the surface on the three days for which the values in the table are given enables us to see why these differences should arise.

The ascents were made about an hour after the time at which the pressures on the charts were read.

Surface Pressures and Currents in Upper Atmosphere:
PRESSURE DISTRIBUTION AT THE SURFACE, 21ST TO 30TH MAY, 1914.—At 7 h. on the 21st the high-pressure area over the Atlantic had advanced across the southern half of the British Isles, France, and northern Spain, while a depression was centred just south of Iceland, the barometer falling between Iceland and Scotland. The distribution on the morning of the 22nd, just before the ascent was made, showed that the low had moved towards Spitzbergen, and that a strong cold northerly current was blowing behind it southwards into the Atlantic from Iceland. The sounding indicated that the south-westerly current was still prevailing over Aberdeen. The temperature of this current, however, was much above that of the northerly current, as indicated by the surface temperatures. The difference in temperature between Iceland and north-east Scotland amounted to more than 20° F., i.e. a considerable temperature gradient existed between these two regions. The results of the sounding show this quite well, and at 3 Km. the fall of temperature both towards the north and towards the west is large. Between 1 and 2 Km. the south-north component of the south-west current was almost destroyed, the components at 1.5 Km. being west-east, 5.9 metres per second, and south-north, 0.7 metres per second, and in the same neighbourhood the temperature gradient was reversed, so that the cold northerly current was apparently already invading the south-west current at that height. During the day the northerly current gradually replaced the south-westerly, and by the following morning the northerly current had become general,

with the result that the surface temperature at 7 h. over the north of Scotland was 10° F. lower than on the previous day. The sounding on the 22nd, therefore, pointed to this mass of cold air to the north-west of the station, for the velocity in the layers above the surface was much in excess of the gradient wind. Consequently a cold northerly current over the north of the British Isles, such as was experienced on the following day, was to be expected.

On the 23rd and 24th a depression, which was indicated to the north-west of Iceland at 7 h. on the 23rd, moved slowly eastwards, and at the same time the high over the Atlantic spread eastwards across the British Isles. On the morning of the 25th a shallow secondary lay between Iceland and the Faroe Islands, but the British Isles were dominated by an anticyclone, being almost encircled by the 1025 mb. isobar. One would therefore expect in the neighbourhood of Aberdeen light, variable winds at the surface, but higher in the atmosphere the conditions to be different. To the west there was a moderately warm south-westerly current being drawn into the depression south of Iceland, while to the east there was still the cold northerly current on the eastern side of the anticyclone. Thus there ought to have been a north-westerly wind produced by this temperature gradient, and the sounding showed that this current existed, increasing and veering with height above 3 Km.

On the 26th the region of the British Isles and the Faroe Islands was an area of high pressure, and though the centre of the area receded southwards during the day, yet at 7 h. on the 27th there was no pressure gradient in the neighbourhood of Aberdeen, and the surface wind was calm. Yet at that time at 1 Km. above the surface there was a moderate wind from north-west, increasing with height and veering rapidly. The pressure distribution indicated at the same time a depression to the north of Iceland. Temperature rose in Iceland during the next twenty-four hours until, at 7 h. on the 28th, it was over 50° F., so that the south-west current must have been a very warm one. This current was therefore the cause of the rise of temperature towards the west whereby the north-west current of the morning of the 27th arose.

The northerly wind had disappeared by the morning of the 28th, the wind, up to 4 Km., being between west and south-west. But the temperature continued to remain higher towards the west at

4 Km. even on the 28th, and so the depression moved north-eastwards, as shown by the charts of the 29th and 30th, and did not descend over the British Isles.

During this period we find, as already stated, that temperature is almost always lower towards the north, and at the same time the paths of the centres of the depressions lie all north of these islands. The fluctuating temperature gradients towards west and east are accounted for by the different currents in front and rear of the depressions as they move eastwards. Without the aid of the charts, therefore, the soundings enable us to form a mental picture of what is taking place, and to forecast to a certain extent what the ensuing conditions, at least so far as wind is concerned, are likely to be.

ADVANTAGE FOR FORECASTING.—So, when the forecaster has, in addition to his chart showing the pressure distribution at the surface, a number of observations made by pilot balloons at various points over the area of his chart, he can either draw the pressure and the temperature distributions at various levels, or, if time does not permit of performing the necessary calculations, he can form a mental picture of these distributions. Such knowledge is of the greatest service to him, for on the distribution of temperature especially depends the changes in the weather conditions likely to be experienced.

CHAPTER IX

Atmospheric Electricity

Through the ether, that all-pervading medium which fills the universe, the energy from the sun reaches the earth. This energy streams through space in electric waves according to the electromagnetic theory, and therefore this medium must be the seat of electric and magnetic forces. All electrical phenomena of the atmosphere must in consequence have their origin in the operation of these forces.

Early Investigations.—Franklin was able to prove by his famous experiment in June, 1752, that the electricity of thunderstorms was identical with that produced by machines in the laboratory. This experiment was repeated by De Romas in France soon afterwards, and also by Richmann in Petrograd, the latter losing his life through approaching too near the end of the conducting wire. Towards the end of the eighteenth century Coulomb endeavoured to unravel the laws governing atmospheric electrical phenomena. In the middle of the nineteenth century, Lord Kelvin (then Sir William Thomson) contributed largely to our knowledge of the theory of the subject, and invented several instruments suitable for the investigation of the phenomena. In more recent times Elster and Geitel have introduced new methods of attack. The great development in the subject since their methods were introduced arises from two recently developed branches of physics, electrical conductivity of gases, and radioactivity.

Soon after Franklin's experiment, Le Monnier proved by insulated rods that the air was charged, even in fine weather, and in 1800 Beccaria of Bologna made regular observations in fine weather of atmospheric electricity, which he termed "fine weather electricity". By the use of insulated rods and an electroscope, Beccaria found the difference in electrical pressure, or the potential difference, as it is called, between the top of the rod and the earth. He came to the conclusion that in fine weather the air is charged positively

relative to the earth, and that the potential increased regularly with height above the earth's surface.

To explain this, Peltier assumed that the earth's surface had a negative charge upon it. This charge, however, is not a free charge, as originally supposed, but an induced charge, and one of the chief problems in atmospheric electricity is to explain why this negative charge is always present on the surface of the earth. There are certain terms constantly occurring in the treatment of electrical phenomena, and before entering farther into the subject, let us consider some of these terms.

Electrical Density, Electrical Force, Electrical Potential.—The Meteorological Congress at Vienna in 1878 published the three following definitions of these terms:

1. The electrical density at a point in the air is the quantity of electricity per unit volume with which the air is charged.

2. The electrical force at a point is the force with which a unit of positive electricity would be acted on if brought to the point without altering, by its inductive action, the previously existing distribution.

3. The electrical potential at a point is the work which would be done by electric force upon a unit of positive electricity passing from the point to the earth, the movement of this unit being supposed not to disturb the pre-existing distribution.

To these may be added the definition of electrical surface density. The surface density of the electrical distribution on the earth is the quantity of electricity on each unit area of the surface.¹

(a) ELECTRICAL POTENTIAL OF THE ATMOSPHERE

Equipotential Surfaces.—In the atmosphere there exists an electric field, and if the surface of the earth were uniform, then the equipotential surfaces would consist of a series of concentric shells surrounding the earth, and the lines of force in this field would be perpendicular to these surfaces and to the surface of the earth. But objects on the earth's surface cause the equipotential surfaces near the ground to become irregular, so that

¹If V denote the potential at a height h above the surface, then the electrical force is represented by $\frac{dV}{dh}$. The relation between the surface density and this electrical force is $\frac{dV}{dh} = -4\pi\sigma$, where σ denotes the surface density.

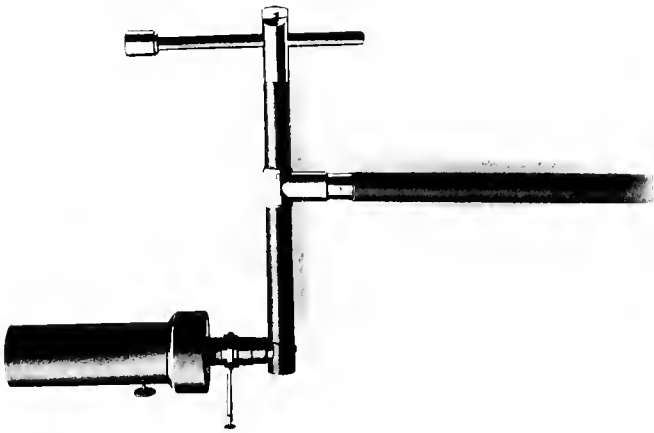

Fig. 88.—Collector

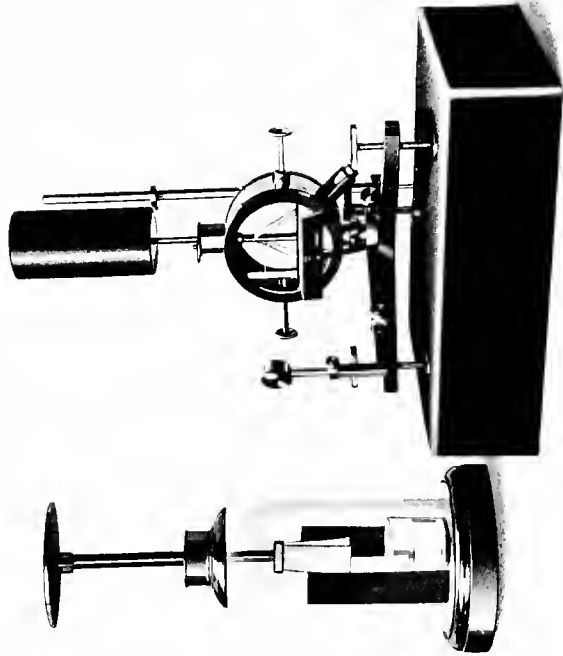

Fig. 89.—Two Electroscopes

a. Simple Gold Leaf Electroscope. *b.* Exner Electroscope with Dissipation Cylinder as used by Elster and Geitel



instead of being parallel, the surfaces become distorted as in fig. 87.

A and B are objects, such as houses or trees, on the surface of the earth. The result is that the equipotential surfaces near the top of a building become crowded together, whereas near the base they are spread out. In any measurements of electrical potential, therefore, it is essential that this fact be borne in mind, otherwise conflicting values will result.

Measurement of Electrical Potential of the Air.—To find the potential at any point above the surface a collector and an electrometer are necessary.

Collectors: THE FLAME COLLECTOR.—As a collector a small lamp (fig. 88, Plate XIV), placed on an insulating stand will serve

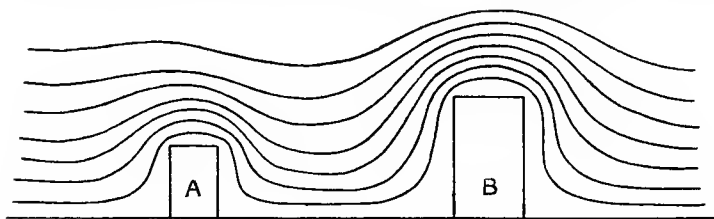

Fig. 87.—The Distortion of Equipotential Surfaces

The flame of the lamp causes convection currents, which continually carry away the induced charge, so that the lamp becomes charged with electricity of the same kind as the air surrounding it, and the potential will be that of the surrounding air. The lamp is connected by a wire to an electroscope or electrometer, and thereby the potential of the air at the point where the lamp is placed is determined.

THE KELVIN WATER-DROPPER.—Lord Kelvin devised another form of collector, the water-dropper. This consists of a copper vessel placed on an insulating support, and from the vessel there projects a long narrow nozzle, 2 or 3 ft. long, ending in a fine jet. From this the water is allowed to fall in fine drops, and the action of the water is like that of the convection currents caused by the flame. The collector quickly takes the potential of the surrounding air, the time required being about 30 seconds.

RADIOACTIVE COLLECTOR.—A more recent form of collector than either of the two above mentioned consists of a preparation

of a radioactive substance. Ionium serves the purpose best, as the effect produced by it remains practically constant. The ionium is precipitated on a metal plate, which is then placed on an insulating stand, with the prepared surface underneath to protect it from precipitation. The time required by this collector to take the potential of the surrounding air is rather longer than that required by either of the other two.

As the distribution of the equipotential surfaces is affected by buildings, trees, &c., the collector should be placed in an open space. If the Kelvin collector is fixed within a building with the nozzle projecting outside, then the measurements obtained are *relative* measurements, and ought to be adjusted by comparison with measurements taken in an open space.

Electrometers.—For the measurement of the potential differences an electroscope or an electrometer is necessary. For rough measurements the gold-leaf electroscope (*a*) in fig. 89, Plate XIV, will serve. The electroscope (*b*) which is used in the Elster and Geitel apparatus has a scale and microscope attached, and is suitable for much finer measurements. The leaves in this instrument are of aluminium foil.

In place of an electroscope a quadrant electrometer may be used. This instrument consists essentially of a light aluminium needle, suspended in a shallow cylindrical box, which is divided into four quadrants. These quadrants are then connected alternately.

Two types of quadrant electrometer are (1) the Thomson Quadrant Electrometer and (2) the Dolezalek Quadrant Electrometer.

THE THOMSON QUADRANT ELECTROMETER.—In the Thomson electrometer the needle is suspended by two silk threads, which carry a small mirror, whereby the deflections of the needle may be read with the aid of a lamp and scale. The needle itself is kept at a constant potential by a platinum needle dipping from it into sulphuric acid contained in the inside of a Leyden jar, which forms the base of the instrument. The jar is charged by means of an electrophorus, and this charged jar maintains the needle at a constant potential.

THE DOLEZALEK ELECTROMETER.—In the Dolezalek electrometer, which is shown in fig. 90, Plate XV, the supporting fibre is a single quartz fibre. It is rendered conducting by being moistened

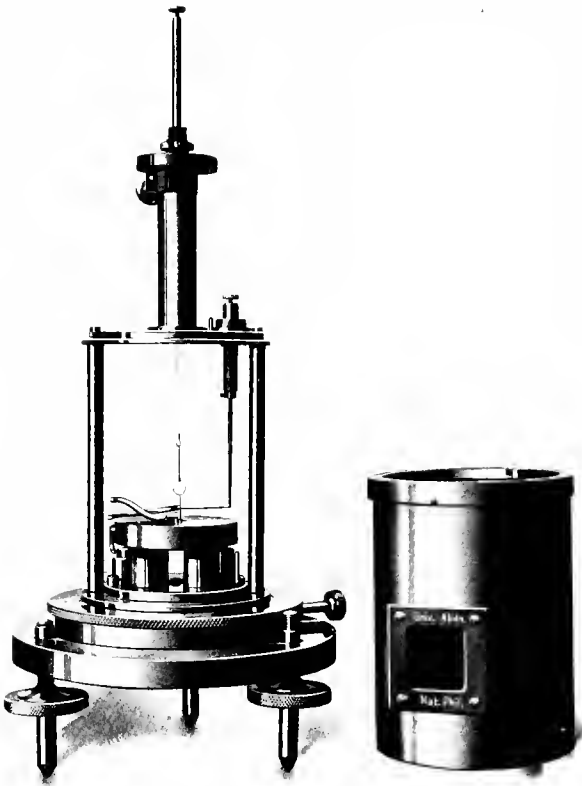

Fig. 90.—Dolezalek Electrometer with cover removed

with a little calcium chloride. To this fibre the small mirror is attached. The needle in this case is kept at a constant potential by being attached to one pole of a battery of cells. In this way the potential can be raised to any desired amount. Contact is made through the supporting fibre.

The quadrants, which are insulated by means of amber pillars, are connected alternately, and then one pair is connected with the collector, while the other pair is "earthed". There is thus a difference of potential between the two pairs of quadrants, and a deflection of the needle, proportional to this difference of potential, takes place. The sign of the charge on the collector will also be indicated, for if it be the same as that on the needle the latter will be repelled; whereas if it be the opposite, it will be attracted.

To calibrate the instrument the pair of quadrants to which the collector is to be attached is first connected to a battery of known voltage, and the deflection of the needle noted. By altering the voltage different deflections are obtained, and so one arrives at the calibration curve of the instrument.

With an arrangement of collector and electrometer, therefore, the potential at any point in the air can be determined.

The Earth's Normal Electric Field.—It is of prime importance to know what the earth's normal electric field is both as regards sign and absolute value, and also what regular variations take place in it. As observations have been carried out at only a limited number of stations, the information regarding the earth's field is rather limited. Also many of the earlier observations were only relative, thereby reducing still farther the information at our disposal.

From information available, however, it is found that the fall of potential near the earth's surface and at approximately sea-level is about 100 volts per metre. With increase in height above sea-level, though still near the earth's surface, this value diminishes. In the free atmosphere it is by no means constant, but decreases rapidly with altitude. It also differs from one part of the globe to another.

The values at any particular station undergo variations, some of which are regular, such as the annual and diurnal variations, while others are large and irregular. The latter are very closely connected with the meteorological conditions of the atmosphere.

Annual Variation. — In the Northern Hemisphere in mean latitudes the strength of the earth's field is greatest in winter and lowest in summer. Thus Kew shows a maximum in December and a minimum in July. On the whole, spring shows higher values than autumn. Observations in the Southern Hemisphere are less numerous than in the Northern, but from results obtained at Samoa, the behaviour appears similar to that in the Northern Hemisphere. On the other hand, in the Antarctic a distinct maximum has been found in February, which corresponds to late summer. During the *Discovery* Expedition to the Antarctic the maximum was found in December and the minimum in June. But with the exception of the Antarctic, the behaviour in both hemispheres is apparently the same.

Diurnal Variation.—In the summer-time the diurnal variation shows a double period, like the barometric variation. The first minimum occurs in the morning between 3 h. and 4 h.; the first maximum about 8 h.; the second minimum occurs during the afternoon, the whole period from 12 h. to 18 h. showing but little variation; thereafter the value rises to a second maximum about 21 h., and then gradually falls again.

At Kew this double oscillation is found all the year round, and also at places near the Equator, such as Batavia. At the latter station the field often becomes reversed during the afternoon.

But at an inland station, such as Potsdam, the double oscillation occurs only in summer. In winter there is but one oscillation, a minimum about 4 h. and a maximum about 18 h. December and January show this in particular. From April to September a double oscillation takes place, while the two intervals between these periods are transition periods.

The morning minimum remains nearly constant in time at any one station all the year round, and at all places on the earth's surface it occurs at the same local time. The second minimum is deeper in summer than the morning minimum, while in winter, especially at inland stations, it is almost missing. Its time of occurrence is not so definite as that of the morning minimum. The morning maximum is the greater of the two maxima in summer. Its time of occurrence varies with the season, being earliest in June, while in winter it almost disappears.

In general the diurnal variation is such that in tropical regions there is a double period over the land and a single period over

the ocean. At the poles the period is a single one. In mean latitudes there is a double period in summer and a single period in winter. This double period is confined to the lower layers of the atmosphere, for even at the top of the Eiffel Tower there exists but a single period, the minimum occurring about 4 h. and the maximum in the early afternoon.

The natural period, therefore, is apparently a 24-hr. period with a minimum about 4 h. and a maximum about 14 h. But the warming of the earth by the sun's rays in summer brings about the maximum at the surface early in the day. Then the effects of the ultra-violet light and of the friction between dust particles produce negative electricity in the atmosphere, and therefore there occurs a second minimum during the afternoon. In the winter-time sunlight has a much less effect, and thus the maximum which occurs in the free atmosphere at about 14 h. does not reach the surface until late afternoon or evening, and no second minimum occurs as in summer.

Variations due to the Meteorological Elements.—Unlike the variations hitherto considered, these variations are very irregular.

(a) **TEMPERATURE.**—At any particular station the highest values of potential difference occur at the coldest time of the year, and vice versa. This, however, appears to be due to the action of the ultra-violet rays, rather than to the temperature, for the minimum often occurs in the period May-June, whereas the period of maximum temperature is July-August. Also stations far apart do not show the same range of potential difference for the same temperature range. The connection between potential fall and temperature cannot be regarded therefore as a very close one.

(b) **PRESSURE.**—The connection between pressure difference and potential difference, though at first sight apparently close, is, on further examination, found to be but slight. Near the surface the potential curve shows a double oscillation like the pressure curve, yet at a short distance above the surface this double oscillation disappears from the potential curve, whereas it remains in the pressure curve. The oscillations in the potential curve cannot be attributed therefore to the pressure oscillations.

(c) **WIND.**—Both the direction and the strength of the wind influence the potential fall, but usually indirectly. It is mainly on account of the particles of dust carried by the wind that the

change arises, though such winds as the föhn and the bora appear in themselves to affect the potential difference.

(d) HUMIDITY.—The absolute humidity changes with the temperature, and the alteration in absolute humidity affects the potential difference in the same way as the alteration of temperature. The potential difference is also influenced by the change in relative humidity, and in places where ground mist forms easily, the normal potential variation is considerably affected. Thus, on low ground, in a calm, clear night, the normal variation is often considerably influenced, while on high ground no alteration from the normal variation may be experienced. Increase in relative humidity is on the whole accompanied by an increase in the fall of potential. Haze produces the same effect. As both haze and mist diminish visibility, we have as a general rule that with increase in visibility there is a decrease in the potential difference, and vice versa.

(e) CLOUDS.—In addition to the ground mists, certain clouds also affect the potential fall. Fine weather clouds, such as cirrus and cumulus, have but little influence on the earth's field. Even though one would expect cumulus, from its proximity to the earth and from its formation, to influence the field, experiment has shown that this is not the case.

On the other hand, cumulo-nimbus, or big thunder clouds, influence the field considerably, the latter often changing sign as the clouds pass across, even when no rain is falling. Strato-cumulus and stratus clouds also affect the potential fall, and the direction of the field is occasionally changed by them.

(f) PRECIPITATION.—But the biggest changes in the earth's field take place through precipitation, very slight rain often causing a negative potential fall amounting to 1000 volts per metre. The most violent changes take place during thunderstorms, when often in a very short interval of time, so short at times that the self-recording apparatus has not time to properly adjust itself, rapid successive changes from large positive to large negative values are met with. In such cases the potential may rise to 10,000 volts per metre, which is very much in excess of the normal value in fine weather.

Lenard Effect.—Rain-drops, on striking the surface of the earth and breaking up, become positively charged, while the air in their neighbourhood becomes negatively charged. This is known as the Lenard Effect. Snowflakes, on the other hand, often possess

a negative charge caused through friction between them and the air, so that the latter is left with a positive charge. With sleet the field alters rapidly from the one sign to the other. With hail the effect is similar to that with rain.

Extra Terrestrial Influences.—The variations hitherto considered are caused by alterations in the atmospheric conditions near the earth's surface. One influence outside the earth's atmosphere, which may probably affect the earth's field, is that due to sun-spots. As these affect the number of the sun's rays and have their frequency closely related to that of magnetic storms, they probably also alter the electric field. Attempts have also been made to find the effect of an eclipse of the sun on the earth's field, but no definite results have hitherto been arrived at.

Alteration of the Earth's Field with Height.—If the negative charge on the earth's surface were the only charge present, then the field would be constant, i.e. the potential difference would be the same for all heights. But measurements made in the free atmosphere during the nineteenth century showed that the fall of potential changed with height, and a negative charge on the earth's surface alone does not explain this. Rather must the air have the charge, and this charge must be positive, otherwise the potential fall would increase with height. Kelvin held the idea that the air itself possessed a charge, and, further, was of the opinion that the earth was electrically neutral.

In the first kilometre the fall of potential changes considerably from time to time and from place to place for reasons already stated, but on an average it remains positive, and, at the surface, has a mean value of 100 volts per metre. At a height of 1 Km. the average value is 25 volts per metre, while between 4 and 6 Km. the value falls as low as from 5 to 10 volts per metre. Practically no measurements have been made beyond this height, but from the results obtained, one can, with fair accuracy, assume that the positive charge in the air is confined to the 5-Km. layer in contact with the earth's surface.

(b) THE CHARGE PER UNIT VOLUME OF THE ATMOSPHERE

With the aid of Poisson's equation¹, the charge per unit volume can be calculated. For at the surface the fall of potential is 100 v./m., and at 1000 metres it is 25 v./m.

$$\therefore \frac{100 - 25}{100 \times 1000} = -4\pi\rho;$$

$$\begin{aligned} \therefore \rho &= \frac{75 \times 10^8 \times 7}{10^6 \times 4 \times 22 \times 100} = \frac{525 \times 10}{88} \\ &= \frac{525 \times 10}{88 \times 3 \times 10^{10}} \text{ e.s.u.} \\ &= 2 \cdot 10^{-9} \text{ e.s.u. per cubic centimetre.} \end{aligned}$$

Also between 1 Km. and 5 Km. the average value is $0 \cdot 2 \times 10^{-9}$ e.s.u. per cubic centimetre. If then the earth has no free charge upon it, the charge in the 5-Km. layer must annul an electrical surface density $\sigma = -2 \cdot 6 \times 10^{-4}$ e.s.u. per square centimetre on the earth's surface. Now the total charge in the 5-Km. layer is $2 \cdot 0 \times 10^{-9} \times 10^5 + 0 \cdot 2 \times 10^{-9} \times 10^5 \times 4 = 2 \cdot 8 \times 10^{-4}$ e.s.u., which is practically the value of the charge on the earth's surface. Thus the negative charge on the earth's surface is accounted for in this way.

(c) THE ELECTRICAL CONDUCTIVITY OF THE ATMOSPHERE

Coulomb's Law.—When a conductor is charged, insulated, and left to itself in the air, it gradually loses its charge. Coulomb investigated this phenomenon experimentally in 1785, and found that it obeyed a definite law. He also found that the rate of loss was dependent on the weather. The law has consequently been called Coulomb's Law. It is an exponential law and may be expressed in the form

$$E_t = E_0 e^{-\alpha t},$$

where E_0 and E_t are the quantities of electricity present at the beginning and after a time t respectively, and α is the coefficient of "dissipation" of the charge, this coefficient changing with changes in the weather.

¹ According to Poisson's equation $\frac{d^2V}{dx^2} + \frac{d^2V}{dy^2} + \frac{d^2V}{dz^2} = -4\pi\rho$ where ρ = charge per unit volume. Now the horizontal components $\frac{d^2V}{dx^2}$ and $\frac{d^2V}{dy^2}$ may be neglected in the present problem, and so $\frac{d^2V}{dz^2}$ or $\frac{d^2V}{dh^2} = -4\pi\rho$.

From the equation above, α may be expressed in the form

$$\alpha = \frac{1}{t} \log \frac{E_0}{E_t} \text{ or } = \frac{1}{t} \log \frac{V_0}{V_t},$$

since the quantities of electricity are directly proportional to the potentials.

Coulomb's explanation of the dissipation of the charge was that the molecules of air, on coming in contact with the charged body, themselves became charged and so gradually carried away the charge. He concluded also that the loss was greater in damp air than in dry air, but this was disproved in 1888 by Linss, who showed that the opposite was really the case. The greater loss in Coulomb's experiment in damp weather arose from the fact that the insulating stand became partially conducting on account of the moisture.

Determination of α .—The problem was not pursued much farther until Elster and Geitel in 1899 again took it up. They used as a dissipating body a black cylinder 10 cm. long and 6 cm. diameter. This they attached by a short stem to an Exner electro-scope (see fig. 89 (b), Plate XIV, page 296). The dissipating cylinder was surrounded by a black metal cylinder 17 cm. wide and 14.5 cm. deep. On the top was placed a black metal lid, and the whole of this outer casing earthed so that it shielded the inner cylinder from the earth's field and also from the sun's rays. A cylinder of wire-netting shielded the electro-scope. In the investigation the inner cylinder was charged, the voltage being indicated by the divergence of the leaves. After fifteen minutes the position of the leaves was read again, the fall indicating the loss of charge. The experiment was then repeated without the inner cylinder in order to eliminate the effect of the electro-scope. The computation was afterwards carried out in the following way. If the potentials in the first case were V_0 and V_t , and in the second case V_0' and V_t' , and the capacities of the cylinder and of the electro-scope c_1 and c_2 respectively, then they found

$$\alpha = \frac{100}{t} \cdot \frac{1}{1-n} \cdot \log \frac{V_0}{V_t} \\ - \frac{100}{t} \cdot \frac{n}{1-n} \cdot \log \frac{V_0'}{V_t'}$$

where $n = \frac{c_2}{c_1 + c_2}$, and the whole is multiplied by 100 to make the numbers more convenient.

This they regarded as giving the complete solution for α , but with good insulation the second term on the right-hand side of the equation may be neglected.

Ions.—Elster and Geitel found that a discharge took place whether the dissipating cylinder was charged positively or negatively, thus showing that both positive and negative charges were present in the air. For positive charges they used the symbol α_+ and for negative α_- , while the ratio of the two they expressed as $q = \frac{\alpha_-}{\alpha_+}$. The charged particles of air they called "ions". Each of these ions has always the same definite quantity of electricity on it. These particles have also been called "electricity carriers".

The values of α_+ and α_- have been found for different parts of the earth's surface by Elster and Geitel's method, and at the surface q shows a value in most places slightly greater than 1. At Kew this value is as high as 1.47, and this high value is probably due to the proximity of the sea. When rain-drops strike the earth's surface they break up and become positively charged, while at the same time the air becomes negatively charged. But on account of the salt in solution in sea-water, both positive and negative charges are given to the air by the breaking up of sea-water, the sea-water itself being left negatively charged. Hence, in all probability, the large value of q obtained at Kew.

The Vertical Current in the Air.—As there are both positive and negative ions in the atmosphere and as the earth has a negative surface charge, the positive ions will be attracted towards the earth where they will give up their charge, and the negative ions will be repelled from the surface. Besides this movement of the ions, the whole air is continually in motion through convection, so that there is a mechanical transport of ions as well. The total current in a vertical direction, therefore, consists of two parts, (1) i_1 that due to the motion of the ions alone, and (2) i_2 that due to convection. If i be the total current, then

$$i = i_1 + i_2.$$

But i_1 is proportional to the strength of the field or $i_1 = \lambda$ (strength of the field), where λ is the conductivity. Both positive and negative ions are present, and so

$$\lambda = \lambda_+ + \lambda_-.$$

Also λ is proportional to the charge on each ion, to the number of ions in unit volume, and to the velocity of the ions;

$$\begin{aligned} \therefore \lambda_+ &= e \cdot n_+ \cdot v_+ \text{ and } \lambda_- = e \cdot n_- \cdot v_-, \\ \therefore \lambda &= e (n_+ \cdot v_+ + n_- \cdot v_-). \end{aligned}$$

As i_2 is proportional to the velocity of motion of the air in the convection current, and also to the charge per unit volume, ρ , then $i_2 = \rho V$.

But this value is very small compared with i_1 , so that to a first approximation

$$i = i_1.$$

When the fall of potential and the conductivity of the air are known, then the vertical current in the atmosphere can be calculated.

Determination of λ .—To determine λ , Schering used a long thin copper wire surrounded by a wire gauze which was earthed. If the wire be raised to a potential of not more than 300 volts, then by Coulomb's law on writing $4\pi\lambda$ for a ,

$$\lambda = \frac{1}{4\pi} \frac{c_1 + c_2}{c_1} \frac{1}{t} \log \frac{V_0}{V_t},$$

where c_1 = the capacity of the cylinder, and c_2 = the capacity of the enclosed portion of the wire, &c.

$$c_1 = \frac{1}{2} \cdot \frac{l}{\log \frac{R}{r}},$$

where l = length of wire, r its radius, and R the distance between the central wire and the wire gauze.

In this way both λ_+ and λ_- can be found.

Observations taken in different parts of the world show that though the absolute values of λ_+ and λ_- vary from place to place, yet the ratio λ_+/λ_- remains comparatively constant in all places. In the Antarctic only does there appear a big difference between the two. A few of the values expressed in electro-static units are given in Table XXV.

Variations in the Conductivity: ANNUAL.—The annual variation curve for Europe has a maximum in June and a minimum in January. In the Southern Hemisphere the maximum is also in summer and the minimum in winter, except in the Antarctic, where the maximum occurs in winter and the minimum in summer, thus showing the same peculiarity as the potential variation.

TABLE XXV

ELECTRO-STATIC UNITS $\times 10^{-4}$

Locality.	λ	λ_+	λ_-	$\lambda_+/\lambda_- = q.$
Iceland,	3.0	1.6	1.4	1.2
Atlantic,	2.1	1.1	1.0	1.14
Pacific (Kidson, 1909-10),	3.4	1.8	1.6	1.17
Antarctic,	4.2	2.6	1.6	1.6

DIURNAL.—The diurnal variations are also similar to those of the potential. In winter there is in general a single period with a maximum in the early morning about 4 h., and a minimum in the afternoon. In summer the oscillations are doubled; a first maximum occurs in the early morning, and a second in the late afternoon, the minima occurring in the forenoon and in the late evening. On comparing the conductivity curves with the potential curves one finds that they are to a large extent the images of one another. Especially is this the case as regards the maximum and minimum of the early morning.

Meteorological Effects.—The effect of the meteorological elements on the conductivity is large, irregular, and in the opposite sense to what it is on the fall of potential. The stronger the sun's rays the greater the value of λ ; the greater the visibility the greater the conductivity, and vice versa. So generally a maximum potential fall is accompanied by a minimum value of the conductivity, and vice versa, though many exceptions are found to this general rule.

Effect of Dust and Heavy Ions.—The dust raised by the wind alters the conductivity but little, for the particles are too large and their velocity is too small to have any great influence. The difference in behaviour between light and heavy ions has been investigated in the laboratory by Sir J. J. Thomson and Lenard. In 1905 Langevin showed that heavy ions were present in the atmosphere in addition to the light ions. These, by reason of their charge, alter the fall of potential, but on account of their comparatively small velocity do not affect the conductivity.

Effect of Clouds and Haze.—Clouds and mist cause considerable variation in the value of λ . In haze λ sometimes changes several hundreds per cent. The ratio λ_+/λ_- is greatest in mist and

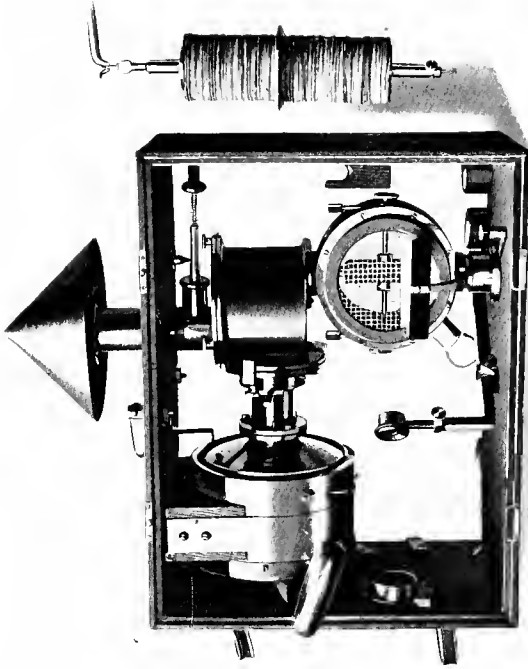

Fig. 91.—Ebert Aspiration Apparatus with Zamboni Pile

haze, q reaching at times a value as high as 1.8. The lowest values of q are found on clear days in summer and days of stratus clouds in winter. Abnormal values occur during squalls and thunderstorms.

(d) IONS

Ions—Their Charge, Number per cubic centimetre, and Velocity.—The conductivity λ is the product of three quantities, e , n , and v . Sir J. J. Thomson has determined the value of e by a method evolved from the discovery of C. T. R. Wilson that these ions serve as nuclei for condensation when no dust particles are present in the air. When vapour condenses on these ions they become visible droplets, and can be counted, and the total charge carried by a number can be measured by an electrometer. As a result Thomson found in 1901 that $e = 3.4 \times 10^{-10}$ e.s.u. A later value determined by Millikan in America is 4.9×10^{-10} e.s.u., and this value is now generally adopted.

To determine n , the Number of Ions per cubic centimetre.—For this purpose Ebert, in 1901, devised the apparatus shown in fig. 91, Plate XVI, and known as the Ebert Aspiration Apparatus or Ion Counter. This instrument measures the product $n \cdot e$, and as e is known, n can be determined. It consists essentially of a cylindrical condenser, inside axis 30 cm. long and $\frac{1}{2}$ cm. diameter; outer cylinder 36 cm. long, and distance between inside and outside 3 cm. The inner axis is connected to an electroscope of the Exner type; the outside is earthed. A fan attached to the end of the condenser enables a definite volume of air to be drawn through the apparatus in a given time. A Zamboni pile, shown beside the instrument in the figure, is used to charge the inner axis to a potential of about 200 volts.

If a quantity M of air be drawn through the apparatus in time t , and the voltage fall from V_0 to V_t , the capacity of the condenser being C , then

$$E = n \cdot e = \frac{C(V_0 - V_t)}{M \cdot 300} \text{ e.s.u., as 1 volt} = \frac{1}{300} \text{ e.s.u.}$$

Both positive and negative ions are present, so that E_+ , E_- , and the ratio $E_+/E_- = Q$ can all be determined.

It must be borne in mind that only the quickly-moving ions are counted by this method.

Variations in E ($= n \cdot e$).—Measurements have been carried

out at several places on the earth's surface, and results similar to those found for the dissipation and the conductivity have been found. Summer shows a maximum and winter a minimum. The diurnal variation follows closely that of the conductivity. The effect of the meteorological elements is the same as it is on the total conductivity, a proof that the quickly-moving ions determine almost entirely the conductivity. The higher the temperature the higher the value of E , and the higher the relative humidity the lower the value of E . In squalls and thunderstorms the values are abnormal; generally the values are high, and often the ions have nearly all the same kind of charge.

Near the surface E has a value of from 0.2 to 0.4 e.s.u. per cubic metre or 0.2×10^{-6} to 0.4×10^{-6} e.s.u. per cubic centimetre, while n varies from 400 to 800 per cubic centimetre. But in the free atmosphere balloon observations show that both the conductivity and the number of ions increase with height. For the first kilometre or so the variation is rather irregular, but above 3 Km. the increase in both quantities becomes quite marked and regular. Thus at 6 Km. an observation gave a value for λ of 20×10^{-4} e.s.u. as opposed to 1.8×10^{-4} e.s.u. at the surface at the same time. This increase is due to the increase in the number of ions, for between 4 and 6 Km. the average value of n is greater than 2000 per cubic centimetre. At the same time the values of E in this region are mostly greater than 1 e.s.u. per cubic metre. No values have hitherto been found at heights greater than 6 Km., but in all probability the conductivity increases still farther by reason of the ultra-violet rays of the sun ionizing the air.

To Determine the Velocity of the Ions.—The velocity of the ions may be determined by drawing air through a cylindrical condenser by means of a fan. The velocity of the air through the condenser can be altered, and also the potential difference between the two sides of the condenser, and so, from a series of deflections obtained thereby on an electrometer, the velocity of the ions can be calculated. As a result it is found that the negative ions have a greater velocity than the positive. The mean values, according to Gerdien, are:

$$v_+ = 1.3 \text{ to } 1.4 \text{ cm/sec for 1 volt/cm.}$$

$$v_- = 1.5 \text{ to } 1.8 \text{ cm/sec for 1 volt/cm.}$$

Ebert's apparatus can also be used for determining the velocity of the ions by the addition to it of an extra condenser known as a

Mache condenser. The values obtained in this way are not very exact, but they show that on the average $v = 1$ cm/sec, and that $v_-/v_+ = 1.1$, i.e. that v_- is greater than v_+ .

(e) THE ELECTRIC CURRENT IN THE ATMOSPHERE

Indirect Method of Measurement.—Under normal conditions of weather the flow of electricity in the air in a vertical direction can be calculated when the fall of potential and the conductivity of the atmosphere are known. But as the equipotential surfaces alter on passing over houses and hills, it is necessary that all values obtained should first be reduced to correspond with those values that would be obtained on an open plain. This is the indirect method of measuring the current.

Direct Method of Measurement.—The direct method of measurement was, however, employed before this indirect method, and Ebert in 1901 was the first to carry out exact measurements of the current. He placed pieces of turf over an insulated metal plate about 2 sq. m. in size, the plate standing 4 m. above the ground. The plate was first earthed and then insulated for a definite time, and afterwards discharged through a galvanometer. Dividing the amount of electricity thus measured by the galvanometer, by the time and the area, Ebert found that

$$i_+ = 1.7 \times 10^{-16} \text{ amp. per square centimetre,}$$

and therefore that the total current was just twice this value.

Wilson's Apparatus.—In 1906 C. T. R. Wilson employed a method of measurement whereby certain errors in Ebert's method were eliminated. The arrangement he used is shown in fig. 92. P is a circular metal plate surrounded by a guard ring G. The plate P is attached to an electrometer or gold-leaf electroscope E. A variable condenser C, the outer plate of which is kept at a constant negative potential by being in contact with the inner coating of the Leyden jar L_1 , is placed in the plate-electroscope circuit. The inner casing of the electroscope is kept at a definite potential through being in contact with the inside of the Leyden jar L_2 , the jar being charged through the point F.

The plate and gold leaf are momentarily earthed, then insulated, and the top, D, removed. This causes a deflection in the gold leaf owing to the rise of potential. The potential is at once brought back to zero by adjusting the variable condenser or compensator C,

and thereby the charge on the test plate is measured, i.e. the charge that would exist on the surface of the test plate if it were earth-connected. The surface density is thus obtained.

The cover, D, is then kept removed for a definite time, the compensator, C, being adjusted to keep the test plate at zero potential. On replacing the cover, D, the

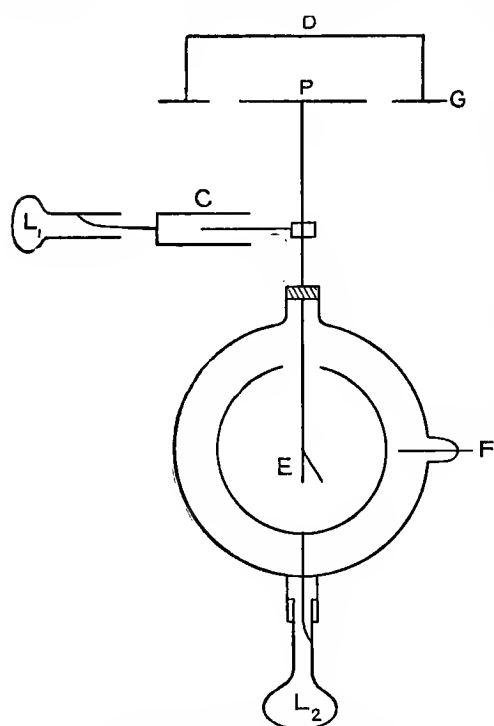

Fig. 92.—Diagram of Wilson's Apparatus (original arrangement)

charge that has entered the plate from the air during the interval can be determined. As the test plate was in the same condition as an earth-connected body during the time that the cover was removed, the normal current in a vertical direction in the atmosphere is thereby determined. Wilson found that the average value of this current was

$$i_+ = 2.22 \times 10^{-16} \text{ amp. per square centimetre,}$$

or a total current of $i = 4.44 \times 10^{-16}$ amp. per square centimetre.

Later measurements in 1909 gave a value of 2.9×10^{-16} amp. per square centimetre, which is in good agreement

with values found in other parts of the world.

In Wilson's experiment the test plate was placed practically on a level with the ground.

At Simla, in India, Simpson, using a much larger test plate and a method differing in certain details from that of Wilson, has found a value of 3.6×10^{-16} amp. per square centimetre.

Values for the Antarctic are in the neighbourhood of 7.1×10^{-16} amp. per square centimetre, which is from two to three times as large as for any other part of the globe.

(f) ELECTRICITY OF THE CLOUDS

Charge on Rain-drops.—Elster and Geitel first attempted to measure the electric current in the atmosphere due to precipitation by catching the rain in a shallow insulated zinc pan which was connected to a quadrant electrometer. But several errors arose in this method, e.g. through the alteration of the earth's field, through the striking of the drops on any object, or from the drops splashing out of the receiver. Later they improved the apparatus by surrounding it with a metal cylinder and covering this with an open wire netting which was earthed. Inside the cylinder a zinc cone was placed to prevent any drops coming in contact with the cylinder from reaching the receiver.

The first continuous photographic record was obtained by Ardenne in 1902. In place of obtaining the record by a photographic method, a Benndorff electrometer may be used. This method has been adopted in Potsdam since 1908, and it has also been employed by Simpson in India.

At first it was supposed that the rain had a negative charge. This hypothesis had been advanced by Peltier, but observations at Simla and at Potsdam, and later in France and at Dublin, showed that the positive sign prevailed. The results for Simla gave 5 per cent of all rains as positive. Also it has been found from observation that the sign of the charge does not alter during ordinary rainfalls, but in squalls and thunderstorms repeated changes in sign take place. The strength of the current during rain is only slightly greater than that of the normal current, being of the order 10^{-16} amp. per square centimetre, but in thunderstorms it may reach values of the order of 10^{-15} or 10^{-13} amp. per square centimetre.

Quantity of Electricity accompanying Rainfall.—Little connection is found between the amount of rain and the quantity of electricity, or the strength of the current. Ordinary rain, even in large quantities, often brings but a small quantity of electricity, whereas a small quantity of rain in a thunderstorm or squall may be accompanied by a comparatively large current.

From the amount of rainfall the mean charge per cubic centimetre can be found, a mean value being 1 e.s.u. per cubic centimetre. Much larger values than this are occasionally found, and the highest values are met with in the slight rainfalls of

squalls and thunderstorms. As a rule the lightest rains have the highest charge per cubic centimetre. Simpson found for a rainfall of

0.14 mm. per minute, a charge of 2.0 e.s.u. per cubic centimetre,
and for 0.42 " " " " " 0.4 " " " " "

Charge on Snow.—Elster and Geitel found that the charge on snow was of fluctuating sign, but the Potsdam observations show a predominance of the negative sign. On the other hand, from observations at Simla, Simpson¹ finds that snow possesses as a rule a positive charge. Snow is in general more highly charged than rain, weight for weight. With sleet great fluctuation in the sign of the charge is experienced. Hail affords results similar to those obtained from rain squalls.

The general conclusion from all these measurements is that the normal vertical electric current in the atmosphere brings positive electricity to the earth, and that precipitation tends to increase this current.

Charge on Precipitation and the Earth's Field.—There is no direct connection between the charge on precipitation and the strength of the earth's field at the surface, and, further, they are very often of opposite sign. The fall of potential often shows greater fluctuation in sign than does the electricity of precipitation, several changes in the direction of the field occurring at times without any change in the sign of the precipitation. Thus often in a squall of *short* duration the precipitation brings down electricity of one kind only, whereas the earth's field at the surface changes sign repeatedly. The greater number of changes of sign of the earth's field as compared with the number of changes of sign of the precipitation is not to be wondered at. For the sign of the earth's field is dependent on a number of things, such as the charge on the air molecules, the charge on the earth's surface, the charge on the precipitation in the air, and the charge on the clouds, together with the induction due to the clouds. On the other hand, the precipitation having once become charged retains that charge till it reaches the earth.

From measurements of the electricity present in precipitation one deduces that the clouds possess peculiar charges, though it is very difficult to explain how these charges arise. Ordinary rain

¹ Simpson, *Proc. of Roy. Soc.*, Series A., Vol. LXXXIII, 1910, pp. 394-404.

clouds are mainly positively charged, but snow clouds are in general negatively charged. Cumulo-nimbus clouds have apparently charges of both signs present, the central mass of the cloud often possessing a charge of a different sign from that of the charges on the surrounding masses.

The Origin of Electricity on Water-drops (Simpson's Theory).—The origin of electricity on water-drops presents considerable difficulty, and several theories regarding it have been set forth. According to Simpson,¹ water-droplets in a rising air current where the velocity of the current is greater than 8 metres per second become broken up, and by the Lenard effect become positively charged, leaving the air negatively charged. Such an effect is seen when a fluid evaporates. Simpson endeavoured to prove the process experimentally, but found difficulty in obtaining simply the effect between the air and the water-drops. However, more recently it has been shown experimentally in Heidelberg that individual drops on breaking up, even without striking an object, become positively charged, and that the charge per cubic centimetre of water is greater when the drops are small than when they are large. This is evidently because smaller drops present a greater surface for the same volume of water. Observation also shows that precipitation of relatively small intensity possesses the greater charge per cubic centimetre. The Lenard effect could very well be regarded as the origin of electricity on water-drops therefore, and also it would explain the excess of electricity of the positive sign on precipitation. But though Simpson's theory is the generally accepted theory at the present day, it cannot be regarded as giving the whole explanation concerning electrical charges on water-drops, and the strong negative charges experienced in squalls and thunderstorms must be due to some other cause or causes.

Visible Electrical Discharges.—When a gas is subjected to a strong electric field, then the gas becomes lit up by the passage of the electrical current through it. In the lower layers of the atmosphere two examples of this phenomenon are met with.

If a body with a sharp metal point be charged, then a current flows out from the point into the air, and this current becomes visible by a shimmering light proceeding from the metal point. If the potential be raised, a brush discharge takes place. With further

¹ *Phil. Trans. of Roy. Soc.*, Series A, Vol. CCIX, pp. 379-413.

increase of potential this continuous brush discharge gives place to a heavier but broken discharge consisting of a spark, as appears when a Wimshurst machine discharges.

St. Elmo's Fire.—This is an example of the brush discharge. It may be seen issuing from lightning-conductors, mast-heads, &c. during squalls and thunderstorms. In mountainous districts it is occasionally observed rising not only from buildings but even from individuals. By the nature of the discharge one can tell whether the electricity in the discharge is positive or negative, and, except in snow, observation shows that in this type of discharge positive electricity predominates. The amount of electricity in the discharge is in general very small, the current on an average being about 1 amp. per square metre of surface.

Lightning.—A better-known form of discharge is the lightning discharge which resembles the spark from an induction machine.

ZIG-ZAG OR FORKED LIGHTNING.—The commonest form is the zig-zag discharge, the irregular path being due to the nature of the air mass through which the discharge is taking place. This irregularity in the path is shown in the two photographs in Plate XVII (*a*) and (*b*). In the first photograph the discharge is seen taking place between the earth and the cloud, and also from cloud to cloud. In this case the discharge appears as a single ribbon of light, but in general this is not so, the discharge appearing as a rule like a river with a large number of tributaries. This branching is visible in the more distant flash in the first photograph, and also more clearly in the second photograph. The next figure, Plate XVII (*c*), which is from a photograph of lightning during a thunderstorm in northern Rhodesia in November, 1904, will enable the reader to form an idea of the difference between a tropical thunderstorm and one occurring in our latitude. The flash in the centre, which is partially obscured by heavy rain, is particularly heavy. The branching is very well developed in the discharge on the right.

SHEET LIGHTNING.—A second form of lightning is sheet lightning. This is sometimes regarded as the reflection of a line discharge, which is itself hidden by the clouds. But though the two resemble one another, yet true sheet lightning is itself a particular form of discharge, as it shows an entirely different spectrum from that of a line discharge. It is a form of discharge inside the clouds or from cloud to cloud, and often occurs at great heights. The duration of a discharge of either of these types is very short,



a. Lightning flash from cloud to cloud :
then to ground



b. Twin flashes of lightning

From photographs by H. Hargrave Cowan, London. Copyright.



Lightning flashes in a tropical thunderstorm (Northern Rhodesia, November, 1904)

amounting to only two or three hundredths of a second. But sometimes the discharge takes place in a series of steps from cloud to cloud. In this way the total time of discharge is considerably increased beyond the time just stated.

BALL LIGHTNING.—A third form of lightning is ball lightning, a form which is very seldom seen. The ball appears to be of the size of a clenched fist or thereby, and moves with moderate velocity. Such a ball bursts with explosive violence, and more than one case is known where a ball has entered a house, causing considerable damage. The explanation of ball lightning presents considerable difficulty, and though various theories have been advanced, no satisfactory explanation has hitherto been given.

Colour of Lightning.—Lightning flashes appear in the majority of cases as white in colour, but red, yellow, and blue lightning flashes have been observed. The colour is due to the gases of the atmosphere through which the discharge takes place. A line discharge produces a line spectrum, in which the lines of nitrogen, hydrogen, and oxygen have been identified. Occasionally there appear also those of some of the rarer gases, argon, krypton, &c. The colour of the discharge appears to be dependent on its direction. Elster and Geitel found that for lightning discharges on the *Sonnblick*, if the earth were the anode, the discharge appeared reddish, whereas if it were the cathode, the discharge was bluish in colour.

Thunder.—The crash or rolling of thunder is due to sound waves set up in the air by the passage of the lightning discharge. These sound waves travel through the air much more slowly than light waves, and thus the sound reaches an observer after the impression due to the light waves, the interval between the two impressions depending on the distance between the observer and the discharge. Sound waves travel at 1090 ft. per second at a temperature of 273° A., and if the time between the flash and the thunder peal be 10 sec. or less, then the discharge has taken place within a radius of 2 miles. A thunderstorm in which this is the case is regarded as a *near* thunderstorm, whereas if the time taken be greater than 10 sec., the storm is regarded as a *distant* thunderstorm.

Lightning-Conductors.—The discharge takes place across the place where the resistance is least, and so chimneys and high buildings are in greater danger than low buildings in the neighbourhood of the former. The best protection against lightning is the lightning-conductor, provided that it is well earthed. A good earth is

absolutely essential. A lightning-conductor badly earthed, instead of being a protection to a building, is a source of great danger. The conductor must not be allowed to corrode at any point, for then the portion above the corroded part is in the position of being badly earthed, thereby becoming a source of danger.

If lightning-conductors were sufficiently numerous over an area, they would practically discharge any cloud passing over that area. But as a sufficiently large number for this purpose is scarcely possible of attainment, those that are in use afford an easy passage to earth for the discharge, so that no damage ensues to the building. As rain helps to increase the conducting power of all substances, there is much less danger to buildings after rain has begun to fall than when it is not raining.

The damage caused by thunderstorms is often very considerable. On the Continent it is, as a rule, much greater than in the British Isles, where, on account of the proximity of the sea, the heat thunderstorms do not develop to the extent that they do on the Continent. Trees are occasionally split from end to end through being struck by lightning, and spires and buildings have from time to time been destroyed. Fig. 93 (Plate XVIII) shows a window-pane with a hole, almost circular, pierced through it. The hole is 6.4 cm. by 6 cm. Beyond the edge of the hole no shattering of the glass can be observed. The glass has been pierced as a thin glass plate is when a battery of Leyden jars is discharged through it, only in this case the hole is very much bigger. The very high temperature of the discharge may be estimated from the fused appearance of the glass at certain points round the edge of the hole.

(g) ORIGIN OF ATMOSPHERIC ELECTRICITY

Old Theories.—Many theories have been advanced as to the origin of atmospheric electricity, but, until comparatively recently, no satisfactory explanation had been given. The old theories, of which there were at least thirty, confined themselves mainly to an endeavour to explain thunderstorm phenomena, and were based very largely on speculation. Of these old theories, Peltier's is the one which has proved of most service in the development of the subject. But, according to it, water vapour rising from the earth should have a negative charge, and therefore the clouds ought to have a negative charge. But investigations, carried out by balloons



Fig. 93.—Effect of lightning on window pane

towards the end of the nineteenth century, proved that the clouds, in the majority of cases, possess a positive charge. Peltier's theory does not, therefore, give a true explanation of the origin of the electricity present in the atmosphere.

Condensation Theory.—In the beginning of the twentieth century, C. T. R. Wilson carried out a number of experiments on condensation, with ions as nuclei. From these experiments a theory of atmospheric electricity was built up by him and Sir J. J. Thomson in this country, and by Gerdien in Germany. Wilson was able to show that condensation could take place without dust particles acting as nuclei, the ions alone serving this purpose, provided that the air was sufficiently saturated. Condensation was found to take place, first, on negative ions, and then on positive. But for condensation on negative ions the air must be 400 per cent saturated, and for positive ions 600 per cent. According to the theory, therefore, condensation took place on dust particles in the lower strata of the atmosphere. For the false cirrus of cumulo-nimbus clouds the negative ions acted as nuclei, while at still greater heights the positive ions served this purpose. But conditions of 400 per cent and 600 per cent saturation are practically unknown in the free atmosphere. Also if separation of the positive and negative ions took place in this way, precipitation ought to bring down more negative electricity than positive, whereas the opposite is the case.

This theory also fails to explain all the facts of observation.

Radioactive Theory.—Attacking the problem in a different way, Elster and Geitel sought to explain the negative charge on the earth's surface as due to the greater velocity of the negative ions. They assumed that the negative ions were absorbed more readily by bodies on the earth's surface than were the positive ions. But if an uncharged body be placed in a badly conducting field, it takes on only a very small negative charge. Consequently Ebert altered the theory and ascribed the effect, not to the free air, but to the air in the ground. In this way, the source of atmospheric electricity is found in the radioactive substances present in the earth's crust. The air rising through the capillaries of the earth's surface gives up more negative electricity, on account of the greater velocity of the negative ions, than positive, and so passes into the free atmosphere with an excess of positive electricity. The earth may therefore be said to impart to the free

METEOROLOGY

atmosphere an excess of positive electricity by a process of breathing. Over the ocean no such breathing can take place, but the wind carries the positively charged ions to all quarters.

To prove the theory, Ebert drew a quantity of conducting air through a bundle of needles connected with an electrometer, and found that the bundle was left negatively charged.

The air issuing from the earth's capillaries has a surplus of positive ions in it. Also it has been proved that the nature of the uppermost layer of the earth's crust has a considerable influence in determining the ratio of the positive to the negative ions issuing from the earth. Therefore this radioactive theory is able to account for the positive electricity present in the atmosphere to which, as already shown, the negative charge on the surface of the earth is due.

(h) THE AURORA

The Aurora most frequently takes the form of an arch of light above a dark segment of the sky, and at right angles to the magnetic meridian. It is seldom seen in low latitudes or at the Equator, but is very common in high latitudes. In the Northern Hemisphere it is called the aurora borealis, and in the Southern Hemisphere the aurora australis.

According to Loomis the belt of greatest frequency in America is between lat. 50° and 62° N., while in Europe and in Asia the belt of greatest frequency is farther north, being situated between lat. 66° and 75° N. Auroral displays are in consequence more common in America than in Europe. The reason for this, in all probability, is to be found in the position of the magnetic North Pole, which is situated in Canada and not at the geographical North Pole.

Streamers.—The inner or lower edge of the arch is well defined, but from the upper edge bright rays of light shoot up towards the magnetic zenith. (See Frontispiece.) These are known as Streamers, or merry dancers, and have a wavy quivering motion. Often the lower edge is ribbon-shaped, as shown in the frontispiece, a form which, in all probability, is a modification of the normal arch.

Curtains and Draperies.—In the Arctic and Antarctic regions magnificent displays are witnessed in which the rays appear like the folds of a curtain, and the brighter, more continuous portions at the bottom like frilled draperies.

Corona.—One of the most beautiful forms which the aurora takes is the Corona. It has a dark centre, surrounded by a crown of light which breaks into radial rays.

Often, however, the only indication of the presence of the aurora is the fact that the northern sky (or in the Southern Hemisphere, the southern sky) is more brightly illuminated than usual.

Connection between the Aurora and Terrestrial Magnetism.—That these two are connected, is shown by the manner in which the magnetic needle is affected during an auroral display. During a sun-spot period also the magnetic needle becomes greatly agitated, so that the three phenomena are apparently all connected.

The curves for the sun-spot numbers flow almost parallel with those representing the horizontal and the vertical intensities of the earth's magnetism, and one would expect that a curve showing auroral frequency would be similar to these.

Observations made at Aberdeen by Mr. Clarke during the past seventeen years show that the variation in the number of auroral displays follows fairly closely the variation in the sun-spot numbers, i.e. a year showing a large sun-spot number shows also a large number of auroral displays. The period of observation, however, is comparatively short, and further information is necessary on the subject before definite conclusions can be arrived at from that point of view.

The Cause of the Aurora.—The height of the aurora varies considerably, but an average height of the base is about 80 Km. At this height pressure is very small, less than two-hundredths of a millimetre, so that the display is taking place in a highly rarified gas. When an electric discharge passes through a rarified gas, the gas is lit up by the passage of the cathode rays, and these rays can be deflected by magnetic forces.

Birkeland's Experiment.—In order to test if the auroral display was similar to that caused by cathode rays in a vacuum tube, Birkeland fixed a sphere, magnetized in a manner similar to the earth, in a vacuum chamber, in such a way that he could send cathode rays towards it. He found that it was possible in this way to obtain a cathode glow round the poles of the magnet. This experiment appears to indicate, therefore, that the aurora is caused by rays, similar to cathode rays, emitted by the sun, and that these rays are emitted in greatest quantity during the time of sun-spots.

METEOROLOGY

Vegard's Conclusions.—Vegard,¹ however, considers that the aurora is produced by rays of the α -type rather than by rays of the β -type, in this differing from Birkeland. "Thus," says Vegard, "as far as our investigations have been carried, the ordinary α -rays are found to possess the right charge, scattering, stiffness, and penetrating power which are necessary to explain most characteristic properties of a great number of auroræ."

However, he is careful to state later in the same paper that it is quite possible that certain forms of auroræ may be produced by rays other than α -rays. Further investigation is therefore necessary before a complete solution can be given to this problem.

Spectrum of the Aurora.—When the discharge in a vacuum tube is examined by a spectroscope, the spectrum consists of a number of lines, the number and position of the lines depending on the nature of the gas. In the same way the spectrum of the aurora shows a number of bright lines and bands. No sign of polarization, due to reflection, is indicated, and consequently the aurora is not due in any way to reflected light. Some investigators have sought to identify argon, neon, and krypton in the auroral spectrum, but it is doubtful if these, especially krypton, are present at these heights on account of their density. The wave length of the chief auroral line is 5578.05° A.U., which approaches closely to the value of the green line of krypton, 5570.5° A.U. Hence the reason that, before the wave length was determined accurately, early investigators regarded krypton as forming one of the gases in the upper atmosphere. But as the above numbers show, later determinations prove that the lines are quite distinct from one another.

¹L. Vegard, *Phil. Mag.*, Vol. XXIII, 6th Series, 1912, pp. 211-237.

CHAPTER X

Atmospheric Optics

Light coming from the sun, moon, and stars, in order to reach the surface of the earth must pass through the atmosphere surrounding the earth, and in the present chapter we shall consider some of the effects produced by the atmosphere and the particles in it on these light rays. The phenomena may be conveniently grouped under three heads: (*a*) phenomena due to the gases of the atmosphere alone, e.g. refraction, mirage, looming, and the twinkling of the stars; (*b*) phenomena due to particles occasionally present in the atmosphere, e.g. halo corona, rainbow; and (*c*) phenomena due to particles always present in the atmosphere, e.g. the blue colour of the sky, sunrise and sunset colours, twilight, and the purple light.

(*a*) PHENOMENA DUE TO THE GASES OF THE ATMOSPHERE ALONE

Refraction.—When a ray of light passes from one medium to another, the densities of the two media being different, the ray, unless it be normal to the dividing surface, is bent or refracted at the common surface of the two media. In passing from a rarer medium to a denser, the ray is bent towards the normal to the dividing surface, and so a ray of light entering the atmosphere from space is continually bent away from its original direction unless that direction pass through the centre of the earth. As the result of this, an object near the horizon, but beyond the earth's atmosphere, appears higher above the horizon than it actually is. At the horizon refraction has its greatest value, this value amounting to 35' of arc. Now, the diameter of the sun and also that of the moon subtend each an angle of about 30' at the earth, and therefore both the sun and the moon appear above the horizon before they have risen geometrically. This means

that the day is lengthened from four to eight minutes in mean latitudes.

The effect of refraction falls off rapidly just above the horizon, amounting to 29' only at an altitude of half a degree. The lower limb of the sun or moon is in consequence raised much more than the upper, so that the disc appears oval instead of circular, the flattening amounting to about one-fifth of the diameter.

The Size of the Sun or the Moon while Rising or Setting.

—To an observer on the earth's surface the sky does not appear as a hemispherical vault at the centre of which he himself is, but as a depressed vault. In other words, the horizon appears farther away than the zenith. The extent of this apparent depression varies according to the manner in which the sky is lit up. In bright sunlight it has been found that the apparent central point of the arc, horizon to zenith, has an altitude of 22°; by moonlight the value is 26.5°; and by starlight, when the moon is absent, 30°. Accordingly, for an angle whose true value is 5°, it has been found that the mean value of the estimated angle on the horizon is: in bright sunlight, 13.3°; by moonlight, 11.1°; and by starlight, 9.6°. At an altitude of 30° to 35° above the horizon the estimated values are for the same 5° angle, 4.9°, 5.1°, and 5.2° respectively. Above this altitude the estimated values for a 5° angle are all less than 5°.

Hence, on the horizon the sun or moon appears larger than the true value; at 30° to 35° above the horizon the disc in either case appears at its true value, while above 35° the disc appears smaller than the true value.

Consequently the estimated diameter of the sun on the horizon is $148/55 = 2.7$ times the true diameter, while that of the moon is $123/57 = 2.2$ times its true value.

This phenomenon is due, therefore, not to refraction, but to the manner in which the angular distances on the sky are estimated by the human eye.

Mirage.—When the air near the surface of the ground becomes heated through contact with the hot surface of the earth, it becomes lighter or less dense than the air above it. Now, light rays in passing from a denser medium to a rarer are bent away from the normal. If the angle of incidence be gradually increased, a point is reached where the ray no longer passes from the denser medium, but is reflected back from the boundary of the two media. So in the case of heated air, where the density increases from the surface

upwards, a ray of light will not pass directly from a distant object to the eye of an observer, but will pursue a curved path. The surface, the angle between the normal to which and the direction of the incident ray is greater than the critical angle, will be tangential to this curve. In other words, the ray will be reflected from this surface. The observer, therefore, from his position in one of the denser layers, sees an inverted image of the object as in a mirror, and the phenomenon gives him the impression that the object is reflected from the surface of water. Hence the term *mirage*, meaning reflection. The phenomenon occurs chiefly during the hot hours of the day, and mainly in hot desert regions. It is also very often seen on tarred road surfaces on warm days.

Looming.—In the mirage the path of the ray is concave upwards, but if the lower layers are colder than the upper, then a ray of light will pass in a path convex upwards, so that to an observer some distance from the object an inverted image of the object will be seen in the sky. Thus the inverted image of a ship which is nearly below the horizon may be seen above its actual position. If the density falls off only very slightly in the surface layers, the only effect may be to lift the object slightly above the horizon. A double image, one part inverted, the other part erect, is occasionally seen above the slightly raised image of the object in the lower layer of air. This takes place when there is a layer of air in which the density falls off quickly above the surface layer just referred to. Rays of light from the object become totally reflected in this second layer, and if the rays from the top of the object cross those from the bottom before total reflection takes place, then an inverted image of the object is seen. If, on the other hand, total reflection takes place without the rays first intersecting, then an erect image is seen immediately above the inverted one. The whole of this phenomenon is known as *looming*, and is just the opposite of the mirage.

Fata Morgana.—This phenomenon differs from the mirage and from looming in the great multiplication of the images and in their fluctuation and distortion. If the image of a lamp be observed in running water, then not a single image but a series of images is seen. Each image will be distinct if the distance between the waves is sufficiently great, compared with the distances from the water to the observer and to the lamp. But if the waves are close together then all the images run into one

long streak of light. The same effect is found when layers of air of different density are not exactly parallel to each other. The rays of light coming from an object at different angles reach the eye of the observer by different paths, and therefore the observer will see a number of images of the object.

The fluctuation and the distortion of the images are both due to the same cause. If the density of the different layers of air becomes altered through mixing by a very light wind, so that only slight differences arise in the original density distribution, then only a quivering is observed. But if the wind is stronger and causes considerable mixing, then objects appear to alter their position repeatedly and to become at the same time distorted. This phenomenon, common in Italy, and of which many records exist dating from the second half of the sixteenth century, is also known in Lecce under the name of "Mutate", i.e. changing pictures, and in Apulia as "Lavandaja".

Scintillation.—When the fluctuations take place quickly and are small, so that they are more like a quivering, then the phenomenon is called "scintillation" or "twinkling". This quivering is seen on a hot day above a bank on the roadside, above a roof, over trees, &c. Another form of the phenomenon is seen in the scintillation of reflected sunlight from distant windows. But the best example is that of the stars.

This scintillation of the stars was studied in ancient times, and Aristotle knew that the fixed stars twinkle, affirming at the same time that the planets do not. Ptolemy was aware that the stars show a greater twinkling on the horizon than when high in the heavens. The change of colour during twinkling was first observed by Kepler.

The three essentials in the scintillation of the stars are (1) the change in position, (2) the change in colour, and (3) the change in brightness. The twinkling or apparent change in position of the stars is greatest near the horizon, and is practically nil near the zenith. The table on following page from Pernter and Exner's *Meteorologische Optik* shows the variation in the intensity of the twinkling for different altitudes.

The Twinkling of the Planets.—Occasionally it is affirmed that the planets do not twinkle, but many observers have been able to see the twinkling of the planets. The phenomenon is not so marked as in the case of the fixed stars, but it does exist, and the

TABLE XXVI

INTENSITY OF TWINKLING

Zenith Distance.	Intensity.	Zenith Distance.	Intensity.
0-10°	0.30	45°	1.36
15°	0.41	55°	2.83
25°	0.54	65°	5.09
35°	0.80	75°	7.89

conditions under which it takes place are given by Kämtz as follows: (1) if the twinkling of the fixed stars is very marked; (2) if the planets are near the horizon. Mercury and Venus show the phenomenon best. Kepler gives the results of two observations—one in December, 1602, and another in June, 1603—in which he observed the marked twinkling of Venus. Both sun and moon show the phenomenon of twinkling at rising or setting, when only a very minute portion of the disk is visible, or during an eclipse, when the eclipse is almost, but not entirely, a total one.

The change in colour during twinkling has long been known to be confined to stars comparatively near the horizon, and Montigny, who was the first to indicate the true explanation of the phenomenon, found no change in colour in stars 40° or more above the horizon. Exner, who developed Montigny's theory, and obtained a complete solution of the problem, found that change in colour took place mainly below an altitude of 34°, and never above 51°.

Cause of Scintillation.—The continual alteration in the density of the air causes the stars to alter their apparent positions, just as takes place in the phenomenon of the *fata morgana*. But to explain the change in colour and brightness it is necessary to investigate this change in density. Accordingly Montigny, in 1878, suggested that there were small air layers or pockets in the atmosphere of different temperature and density to that of the air surrounding them. Later, Exner was able to prove the presence of these layers, and to show that their length was from 1 cm. to 20 cm. These air layers act as concave and convex lenses, dispersing or collecting the rays. Further, these layers are continually in motion as the air is moving. In this way the image of the star is continually altering its position, giving rise to the effect of twinkling. Also, the number of rays reaching the eye is continually varying from moment to

moment, whereby the intensity or brightness of the star is continually varying.

The variation in colour arises on account of these small air layers crossing the paths of the rays where the distance between the extreme rays, red and violet, into which the white light has been resolved by the refraction of the atmosphere, is sufficiently great to permit of these extreme rays being refracted, the one after the other. This can only arise with starlight when the stars are comparatively low, and for light reflected from objects on the earth's surface when the objects are distant at least 10 to 12 Km. If the distance between the extreme rays is not sufficiently great, as happens when a star is high in the heavens, then no colour-effect arises, as all colours will be refracted together.

The colour-effect is therefore confined to stars having an altitude of not more than 51° as an outside limit, and in the majority of cases not more than 34° , whereas the apparent change in position and in intensity takes place at all altitudes, though in and near the zenith it is very feeble.

This theory of scintillation is known as the Montigny-Exner theory.

The non-twinkling of the planets at times can also be explained by this theory. Since the planets subtend at the earth a larger angle than the distant fixed stars, which on account of their distance are mere points of light, the individual points of the surface scintillate independently of each other. For mean values of these small air layers or pockets, therefore, the result is that the surface appears as a uniform bright disk, no scintillation being apparent.

It is also evident that the best night for studying the stars astronomically is a night on which twinkling is at a minimum.

(b) PHENOMENA DUE TO PARTICLES OCCASIONALLY PRESENT IN THE ATMOSPHERE

Particles occasionally present in the atmosphere are ice crystals and droplets of water, which become visible in the form of clouds or rain. To ice crystals are due halos with all the accompanying phenomena of parhelia or mock suns, paraselenæ or mock moons, sun and moon pillars, &c., which appear round the sun and moon. The colours exhibited are generally comparatively slight.

Colour-effects are produced to a much greater extent by water-



a. Solar Halo with arc of contact and a Parhelion

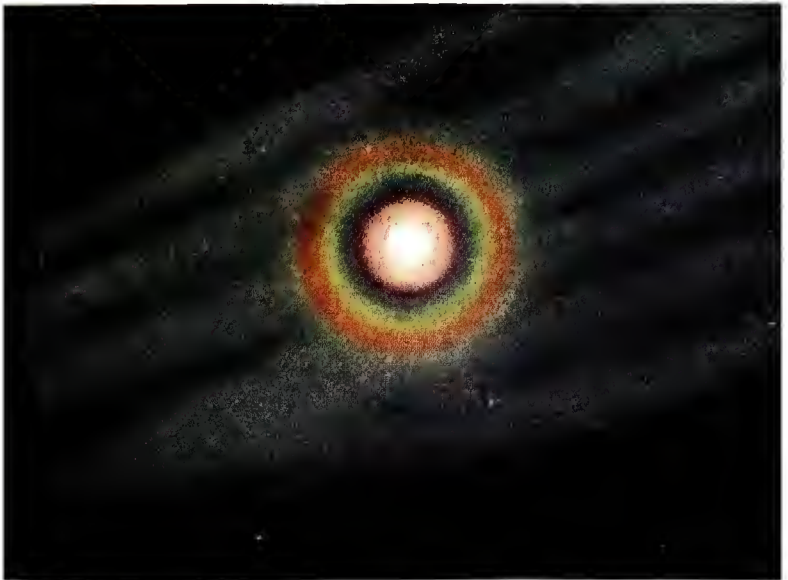

b. Lunar Corona

droplets. These cause coronæ round the sun and moon, though it has been shown that ice crystals can produce these also. At times, instead of the sun or moon forming the centre of the corona, the shadow of the observer is seen on a cloud, with his head surrounded by a corona. Such a phenomenon is known as a "glory" or "Brocken Spectre". To falling water-drops and water-droplets in the clouds are due the different rainbows.

These various phenomena may be grouped under three heads:

1. Phenomena caused by refraction and reflection—halos, &c.
2. Phenomena caused by diffraction—coronæ, &c.
3. Phenomena caused by diffraction in conjunction with refraction and reflection—rainbows.

Halos.—Under the phenomena of halos are included: (1) rings with the sun or moon as centre; (2) the horizontal ring parallel to the horizon, and passing through the sun or the moon; (3) tangent arcs to the first rings; (4) parhelia and paraselenæ; (5) sun and moon pillars and crosses.

The following details, though given with reference to the sun, apply equally in the case of the moon:

THREE HISTORIC HALOS.—All the phenomena are very seldom seen at one and the same time. There are, however, three historic examples in which all the phenomena mentioned above, together with certain others, appeared at one and the same time. These are: (1) the halo display seen at Rome in 1630; (2) the halo display seen at Danzig on 20th February, 1661; and (3) the halo display seen at Petrograd on 18th July, 1794. For a full description of these the reader is referred to Pernter and Exner's *Meteorologische Optik*.

As a rule, however, only fragments are seen. The part which appears most often is the inner ring of 22° radius.

The rings with the sun as centre are in general two, one with an angular radius of 22° (more exactly $21^\circ 50'$), and a second with an angular radius of 46° (more exactly $45^\circ 46'$). A third with an angular radius of 90° has been observed, but it is of extremely rare occurrence.

THE 22° HALO.—The halo of 22° , which is shown in Plate XIX (*a*), is coloured in the inside, the red colour appearing nearest the sun. The blue on the outside is practically lost, largely on account of the light reaching the eye from ice crystals not in a position to produce minimum deviation, so that only the red and yellow are visible. By

moonlight, by reason of the feeble light, the ring appears almost white, no colour being distinguishable. Between the inner edge of the ring and the sun the sky appears very dark. This arises from the fact that the rays forming the inner edge are the least refrangible rays, and are at the position of minimum deviation, and consequently no light will reach the eye from inside the circle. On the outside, on the other hand, light will reach the eye from ice crystals not in a position to produce minimum deviation on the light rays, and therefore the edge is no longer sharp, but fades away gradually. Further, the breadth of the ring would be equal to the apparent diameter of the sun if the light rays were all of the same colour, but owing to the different refrangibility of the light rays the red is less deviated than the violet, whereby the ring is broadened.

THE 46° HALO.—The ring of 46° radius is similar to that of 22°, but is generally much fainter. The colours are arranged in the same order, and there is a similar dark space with a sharp edge on the inside of the ring.

THE 90° HALO.—The 90° ring shows no colour, appearing always as a white ring. Very few observations of its breadth have been made, but it is generally regarded as of the same breadth as the sun's disk or as the horizontal ring.

Horizontal Circle.—The horizontal circle, or circle of parhelia, passes through the sun, and is at a height above the horizon equal to the altitude of the sun. On it are situated, as its name shows, the different parhelia. It is white, showing no colour except at the parhelia. Situated upon it, exactly opposite to the sun, is the counter-sun. In breadth it is equal to the diameter of the sun's disk. Very often only fragments of this ring are visible.

Tangent Arcs.—Vertically above and below the sun on the 22° and 46° rings are small tangent arcs. These arcs take various forms, but the most common form is that shown in fig. 94. The ends of the arc in this case bend upwards at the top and downwards at the lower edge. The lower tangent arcs are seldom seen, even on the 22° halo. For the 22° ring the sun must be at least 25° above the horizon before the tangent arc is visible, and as the sun must be 50° above the horizon before the lower tangent arc of the 46° halo could be seen, it has never been visible. The arcs are coloured in the same way as the rings to which they are tangential, i.e. with the red next the sun. Though the 46° halo is almost always fainter in colour than the 22° halo, yet at times the upper tangent arc of the

46° halo is exceedingly brilliant, far surpassing in brightness that of the 22° halo. At other times, however, it is quite faint.

Instead of bending upwards at the top of the halos, the tangent arcs occasionally bend downwards as forming part of an ellipse whose minor axis is equal to the diameter of the halo in question. A few cases have been observed where this ellipse was complete. Another form that the arc takes resembles the horns of cattle. In this form the arc at the top first bends upwards, and then becomes nearly horizontal or has a slight inclination downwards

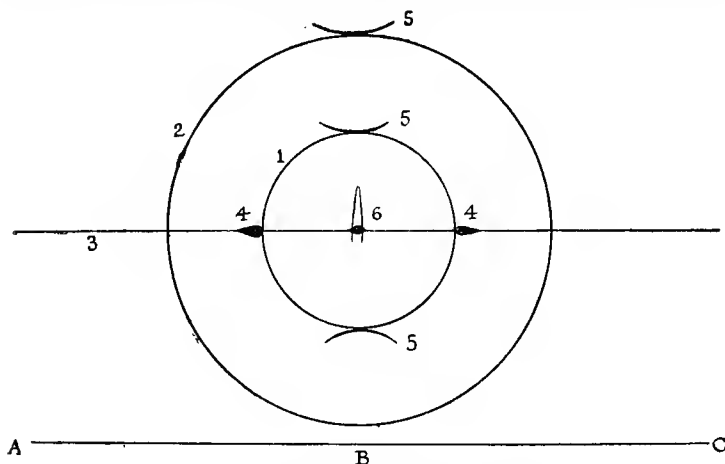

Fig. 94.—Halos and accompanying Phenomena

A, B, C, Horizon. 1, Halo of 22°; 2, halo of 46°; 3, white horizontal circle parallel to the horizon and passing through the sun; 4, parhelia; 5, tangent arcs; 6, sun pillar and cross.

Parhelia, Paraselenæ.—Parhelia appear near the points where the horizontal circle cuts the 22° halo, but the position of these parhelia varies with the altitude of the sun above the horizon. The following figures show the position of the sun and of the parhelia:

TABLE XXVII

Altitude of Sun.	Angular distance of Parhelia.
3° 40'	22° 4'
9° 15'	22° 26'
20° 39'	23° 6'
30° 33'	25° 13'
37° 54'	27° 12'

This table shows that the higher the sun, the greater the distance of the parhelia from the sun. The vertical diameter of these parhelia is about the same as, or perhaps slightly greater than, that of the sun.

Vertically above and below the sun on the 22° halo are two other parhelia, but they differ from those just mentioned in that they possess no definite boundary, but appear simply as two bright spots where the tangent arcs touch the ring.

The 46° halo also possesses parhelia in positions similar to those of the 22° halo, but the horizontal parhelia are not nearly so bright as in the first case, and seldom show any distinct colouring. The lower of the two vertical parhelia has never been observed, but at the junction of the upper tangent arc the colouring is often exceedingly brilliant.

Besides the parhelia mentioned there are present on the horizontal circle the counter-sun and two counter-parhelia. The mean distance of these counter-parhelia from the sun is $121^\circ 15'$, and they show no coloration, appearing always white. No ring except the horizontal circle has been observed passing through them. Occasionally parhelia are observed on the 90° halo, but as this halo is very seldom seen these parhelia are very uncommon.

Sun Pillars and Crosses.—Sun pillars are bright columns of light stretching up from the sun to a height of 15° to 20° . They are always single coloured. If the sun is well above the horizon the sun pillar appears as a dazzling white column, but if the sun is on the horizon it appears red, especially when the sun is going down. Sometimes the pillar stretches below the sun also, but the length below is very much shorter, amounting to a few degrees only. When the horizontal circle appears at the same time in the neighbourhood of the sun the two form a cross. This is the only combination that forms a cross. The intersection of any of the ring halos with the horizontal circle is not regarded as a cross.

In addition to these phenomena several others occasionally occur, but their frequency is small. For a complete account of all halo phenomena the reader is referred to works on meteorological optics.

The Cause of Halos.—Halos arise from the presence of ice crystals in the atmosphere, as was first shown by Mariotte. Before Mariotte gave his solution of the problem, Huygens had endeavoured to show that the phenomena were due to the refraction

of light by small spheres, the centres of which were composed of opaque snow surrounded by water, but this theory did not explain all the phenomena. Young in England and Venturi in Italy, starting from Mariotte's theory, were able to show that all known halo phenomena were due to ice crystals. The theory was later firmly established by Galle and particularly by Bravais.

For a complete understanding of all the phenomena, an exact knowledge of the different ice crystals and ice needles is necessary. Here we shall confine ourselves to one or two forms of ice crystals. The commonest form of ice crystal is the hexagonal prism, terminated by flat ends perpendicular to the axis. In such a crystal the angle between two alternate faces is 60° , and that between a face and an end is 90° .

Ice Crystals that Cause the 22° and 46° Rings.—When a ray of sunlight falls on such a crystal it is refracted both on entering and on emerging, so that the direction on emerging is different from that on entering, i.e. the ray undergoes a deviation on passing through the prism. For one particular position of the prism this deviation is a minimum, and when that is so the angle of incidence is equal to the angle of emergence. If D denote the deviation in degrees, i the angle of incidence, and A the angle between two alternate faces of the ice crystals in the first case, or between a face and an end in the second, then the relation between these quantities is

$$D = 2i - A.$$

But if r is the angle of refraction, $A = 2r$, so that

$$D/2 = i - r.$$

Now, if n is the index of refraction of the substance,

$$n = \frac{\sin i}{\sin r},$$

$$\text{i.e. } \frac{\sin i}{\sin r} = \frac{\sin \frac{D+A}{2}}{\sin \frac{A}{2}} = n = 1.31 \text{ for ice for yellow light}$$

The index of refraction for ice varies from 1.307 in the red, to 1.317 in the violet, giving a value of 1.31 for the yellow.

$$\text{Case I. } A = 60^\circ \quad \text{then } D = 21^\circ 50'.$$

$$\text{Case II. } A = 90^\circ \quad \text{then } D = 45^\circ 46'.$$

In this it has been assumed that the incident light passes

through the prism at minimum deviation, is perpendicular to the edge of the prism, and is homogeneous. Under these conditions the sun would appear surrounded by two rings, the width of each being equal to that of the sun's disk. But there are rays refracted not at minimum deviation, and also rays which pass obliquely through the ice crystals, and these rays will appear on the outside of their corresponding halos. But no light will reach the eye from regions where the deviation is less than the minimum. Hence the space inside the halo is dark and the edge is sharp, whereas the outside fades off gradually.

The red rays are least refracted, whereby the inside of the halo appears red. This is the only part of the halo which has a pure colour. In the other parts the colours overlap, partly on account of the breadth of the sun's disk, but mainly on account of oblique refraction. The orange appears faintly, but on the outside the colour is nearly white.

Reason for the Parhelia.—The crystals to which the halos are due are mainly in the position of minimum deviation, with their axes perpendicular to the plane of refraction. But as the crystals are falling freely in the air the majority tend to fall in one or more particular ways. The long crystals mostly fall with the axis either vertical or horizontal, and the short flat crystals either edgewise or flatwise. Those parts of the halo due to the majority of the crystals are thereby intensified. If the sun is on the horizon, the parts of the 22° halo caused by the vertical crystals are intensified, and there arise in consequence the parhelia. When the sun is not on the horizon, the light rays no longer fall perpendicularly on the vertical ice crystals, and the minimum deviation for oblique incidence is greater than that for perpendicular incidence. Also the value increases with the obliquity of the rays. The parhelia therefore separate out from the halo as the sun rises above the horizon, though they still keep on the same level as the sun.

If there be an excess of hexagonal prisms or plates with the axis horizontal, these will form parhelia above and below the sun. These parhelia will lie on the halo if the axes of the prisms are not only horizontal but also perpendicular to the vertical plane passing through the sun and the observer. But they may lie in any other horizontal direction, so that a continuous series of such parhelia may result. When that is the case, they produce the tangent arcs at the top and the bottom of the halo proper

Vertical hexagonal crystals produce the horizontal parhelia on the 22° halo, and to these crystals also are due the parts of the 46° halo immediately above and below the sun, only in their case the light is refracted through the 90° prism instead of through the 60° prism. This explains the greater brilliancy of the 46° tangent arc as compared with that of the 22° tangent arc, as the number of crystals with axis vertical is greater than the number with axis horizontal. For the same reason the horizontal parhelia on the 46° halo are much fainter than those on the 22° halo.

The horizontal ring through the sun shows no trace of colour except at the parhelia, and is due to the *reflection* of the rays from the vertical faces of the prisms.

Coronæ.—These are coloured rings seen around the sun or the moon, and appear when the light from these bodies passes through white, fleecy clouds. The colours are much more marked in the corona than in the halo, and are arranged in the opposite direction, the red on the *outside*, the violet on the *inside*. The corona is not always developed to the same extent. Very often only a bluish ring appears on the inside, followed by a yellowish and then by a brownish-reddish ring on the outside. This appearance is called the Aureole.

Coronæ are formed in alto-cumulus clouds, and to a slight extent in strato-cumulus, but the best examples are seen in cirro-cumulus. Plate XIX (*b*) (p. 326) represents a corona in cirro-cumulus. Occasionally two or three coronæ form round the sun or moon, at one and the same time, but in each case the red colour is on the outside.

Glories.—Glories are exactly like coronæ, but instead of the sun or moon being in the centre, the shadow of the observer's head appears there. The source of light is behind the observer, and the rays, passing him, fall on mist or thin cloud. The shadow of the observer is thus cast on the cloud, and round his head an aureole or series of coloured rings forms exactly as in the corona. Glories are also very well seen round the shadows of aeroplanes on clouds.

Iridescent Clouds.—Iridescent clouds have been well described by Dr. G. Johnstone Stoney,¹ from whose description the following is mainly culled: "When light cirro-cumulus clouds occupy the sky, then the edges and lighter parts of the clouds show soft shades of colour like those of mother-of-pearl, among which charming pinks and greens are very clearly seen. Generally these colours have no

¹ *Phil. Mag.*, Fifth Series, Vol. XXIV, p. 87.

particular arrangement. But in the thicker parts of the clouds a definite part of a corona shows itself with the colours arranged in order, and following the sinuosities of the cloud."

Cause of the Corona.—In the corona the red is on the outside and the violet on the inside, so that the corona is not due to refraction, as the halo is, but arises through diffraction of light. If a beam of light pass through a small pin-hole, and the image of the hole be caught on a screen, then the central image of the hole is surrounded by a number of bright and dark rings called diffraction rings. If the holes be increased in number the effect is simply intensified.

Fraunhofer, who was the first to give an explanation of the corona, placed a number of small tin-foil spheres, 0·83 mm. diameter, between two plates of glass, and found the same effect on allowing light to pass through the plates as when the light was allowed to pass through a number of small, round holes. Now, a cloud consists of a number of minute drops, and these droplets are small spheres. Also, although the water-drops are transparent, the transmitted light has no effect on the diffracted light, as the former comes to a focus very near the droplets, and then diverges. Fraunhofer, therefore, by his experiment was able to demonstrate the cause of the corona, and to show that the phenomenon could be produced either by opaque or transparent spheres.

Further, he proved as a result of experiment (1) that the intensity of the corona depended on the number of the water-drops; (2) that the size of the coloured ring was inversely as the diameter of the drops; and (3) that the greater the inequality in the size of the drops the greater the irregularity in the phenomenon.

The angular radius of a corona varies from 1° to 10° .

Halo and Corona.—Sometimes coronæ appear in clouds consisting of ice crystals as well as in clouds composed of water-drops, the crystals behaving in the same way as the water-drops. Occasionally both a halo and a corona are visible at one and the same time, the one caused by refraction and the other by diffraction. Very often, however, when the two phenomena appear at the same time, there are two cloud layers present, the upper or cirro-stratus layer producing the halo, the lower the corona.

Glories are explained in the same way as coronæ, only the glory is caused by reflected light in place of transmitted light.

Iridescence in clouds follows the same explanation.

Rainbows.—The rainbow appears as a strongly coloured bow, the colours ranging from red to violet, when a rain-sheet is in front of the observer and the sun behind him. The centre of this bow or segment of a circle is the position of the counter-sun, so that the rainbow appears as a semicircle only when the sun is on the horizon.

PRIMARY AND SECONDARY BOWS.—Often two rainbows appear, a primary and a secondary, the secondary being seen outside the primary. In the primary the red colour is on the outside and the violet on the inside, whereas in the secondary bow the colours are reversed.

COLOURS OF THE RAINBOW.—The breadth of the various colour bands varies from bow to bow, and not only so, but the whole width of the bow varies from bow to bow. The bow consists of at most six colours (red, orange, yellow, green, blue, violet), indigo being practically always absent. Occasionally only four or five colours are visible, and at times only three. A portion of a rainbow appears on the nimbus cloud, Plate V (*a*), (p. 166). A faint trace of the secondary is also visible.

SUPERNUMERARY BOWS.—Besides the primary and secondary bows, there are sometimes visible two series of bows, one series inside the primary, the other outside the secondary. These are called the Supernumerary Bows. They appear and disappear often quite rapidly, and their colour also changes quickly. The colours are mainly green and purple, or green, blue, and rose colour. These supernumerary bows are separated from the two principal bows and also from each other by colourless intervals.

Between the primary and the secondary bows the space, as a rule, appears dark. But occasionally brightly coloured bands like the portions of a rainbow are observed crossing this dark interval. It has been suggested that these bands arise from the reflection of the sun on a water-surface acting as a new source of light. This explanation is not altogether satisfactory, however, and no complete explanation appears hitherto to have been given.

THE WHITE RAINBOW.—Sometimes the rainbow appears with a broad white band in place of the green and blue. On the outside there is a band of light-orange colour, and on the inside a slightly coloured violet ring. This is known as the White Rainbow. The secondary bow also appears, though of much rarer occurrence, with a white central band and the colours in the inverse order, violet on the outside, and yellow or red on the inside. Often one or two

supernumeraries are present, and are remarkable in having their colours arranged in the inverse order from the normal.

The Cause of the Rainbow.—The rainbow arises through the joint action of refraction, reflection, and diffraction of light by drops of water. This can be shown experimentally by filling a glass globe with water, and holding it in the rays of the sun. If the globe be viewed at a definite angle, the primary and also the secondary bows may be seen.

The first attempt at an explanation of the rainbow, both primary

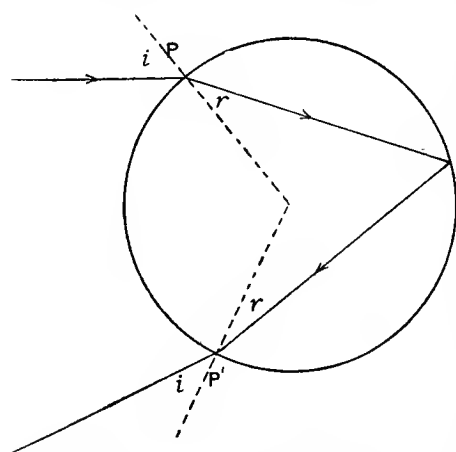

Fig. 95.—Passage of a Ray of Light through a Raindrop

and secondary, appears to have been made by Theodorich in 1311, but the work was not published. The same results were independently discovered by De Dominis in 1611, but it was left to Descartes to point out that the phenomenon was due to the concentration of the rays in particular directions. This was done in 1637. Newton, by his discovery of the different refrangibility of the various coloured rays,

was able to explain the various colours of the rainbow.

Up to this point the explanation of the rainbow was based on refraction and reflection alone, i.e. the theory was a geometrical theory. The geometrical theory of the rainbow held sway long after Newton's time, but it only affords a partial explanation of the phenomenon. It takes no account of the supernumerary bows at all. The first to point out that the complete theory of the rainbow could only be obtained by an application of the general principles of interference was Young, and in 1838 Airy was enabled by this means to give a complete solution of the problem.

Geometrical Theory of the Rainbow.—As the geometrical theory enables us to trace easily the path of the ray through the water-drop, we shall consider the problem from that point of view first.

Let a ray of light fall on a spherical drop, and let fig. 95

represent the path of the ray as it passes through the sphere. The deviation produced on the ray from two refractions and one reflection is

$$D = 2(i - r) + \pi - 2r,$$

where i = angle of incidence, and r = angle of refraction.

If there be κ reflections inside the drop, then

$$D = 2(i - r) + \kappa(\pi - 2r) = \kappa\pi + 2\{i - (\kappa + 1)r\} = \kappa\pi + 2\{i - pr\}$$

where $p = (\kappa + 1)$.

The rays which form the rainbow are those that suffer minimum deviation only. As D is dependent on i and r , and i and r are connected by the relation $\sin i = n \sin r$, where n is the index of refraction, therefore there is a particular value of i for which D is a minimum. If D is a minimum, and since

$$D = \kappa\pi + 2\{i - pr\},$$

$$\therefore \frac{dD}{di} = 0 = 1 - p \frac{dr}{di}.$$

But $\sin i = n \sin r$, and

$$\therefore \cos i = n \cos r \frac{dr}{di} = \frac{n \cos r}{p}.$$

$$\therefore p \cos i = n \cos r.$$

If I be the value of i , and R the value of r for minimum deviation,

$$\therefore p \cos I = n \cos R,$$

$$\text{or } p^2 \{1 - \sin^2 I\} = n^2 \{1 - \sin^2 R\} = n^2 - \sin^2 R,$$

$$\therefore \sin^2 I = \frac{p^2 - n^2}{p^2 - 1}.$$

If $p = 2$, i.e. $\kappa = 1$, then $I = 59^\circ 24'$, and $R = 40^\circ 13'$, while

$$D = 180^\circ - 42^\circ 4'.$$

Cause of the Primary and Secondary Bows.—But as a ray of white light consists of a number of colours, the less refrangible colour is less deviated than the more refrangible, and for a bow arising from one internal reflection the outside is red. Also no ray has a less deviation than the red, which is minimum, so that no light reaches the eye from beyond the red, i.e. the red edge is sharp and the space beyond the red edge is dark. As violet is the most refrangible colour in the ray, the inside of the bow appears violet. But light which is not at minimum deviation reaches the eye from this edge of the bow, so that this edge is not so sharp, and the intensity of the light decreases gradually inwards.

The primary bow, therefore, which arises from rays undergoing one reflection is red on the outside with the outside sharp, and violet on the inside, but on this side the edge is not sharp. The mean angular distance from the antisolar point is $42^{\circ} 4'$, according to the geometrical theory. For the red the actually observed distance is $42^{\circ} 1'$ and for the violet $40^{\circ} 20'$. The reason for this discrepancy between the observed and the theoretical distances will appear later.

When $\kappa = 2$, the deviation is $\pi - 129^{\circ} 4'$, and this gives rise to the secondary bow, with the red on the inside and the violet on the outside. As in the case of the primary, the red edge is sharp because the deviation is there a minimum, while on the violet edge the intensity of light decreases gradually. This explains the dark space between the two bows, and the diffuseness on the inside of the primary and the outside of the secondary. The mean angular distance of this bow according to the theory is $50^{\circ} 56'$. The actual distance for the red is $50^{\circ} 58'$, and for the violet $54^{\circ} 10'$.

The lunar rainbow shows coloration only faintly, and has in consequence been wrongly styled the white rainbow. But the lack of intensity of colour in the lunar rainbow is due to the small intensity of moonlight compared with that of sunlight.

Reason for White Bow.—The white band in the white rainbow arises from an overlapping of the colours. This occurs when the drops are very small, and for drops with a radius $30 \cdot 10^{-6}$ cm. or less the region between $40^{\circ} 40'$ and $38^{\circ} 40'$ from the antisolar point appears white. As this bow is due to minute drops, and occurs during fog or mist and not during rain, it might almost better be styled a mist-bow than a rainbow.

The geometrical theory gives no explanation of the supernumerary bows, and for an explanation of these we have to turn to the undulatory theory of light.

Undulatory Theory of the Rainbow.—Rays emerging from the drop near the point P' , fig. 95, consist of two sets, those above P' , and those below P' . Some of the former are parallel on emergence to some of the latter, but they have travelled over different paths within the drop, and therefore they are not in exactly the same phase. In the neighbourhood of minimum deviation there is, then, not a single maximum, but a maximum followed by a series of bright and dark bands. Therefore together with the primary bow there is formed on the inside a series of supernumerary

bows, and with the secondary, another series on the outside. The distances between the principal bows and the supernumeraries, and also between the supernumeraries themselves, depends on the diameters of the drops.

Airy found that, according to the theory of interference, the first rainbow or rainbow proper was not exactly in the position of minimum deviation, but had a deviation a little greater. The angular radius of this bow, therefore, is a little less than that given by the geometrical theory, while that of the secondary is a little greater. This explains why the mean deviations given above differ from the actual values.

Airy's explanations were verified later experimentally by H. Miller, who allowed a pencil of sunlight to fall on a thin vertical jet of water, when both the primary and secondary bows were seen, together with a large number of the supernumeraries.

(c) PHENOMENA DUE TO SMALL PARTICLES ALWAYS PRESENT IN THE ATMOSPHERE

There are certain phenomena, such as the blue of the sky, sunrise and sunset colours, and twilight effects, which are caused by minute particles of dust in the atmosphere, or even in some cases, as the late Lord Rayleigh has shown, by the air molecules themselves.

The Blue Colour of the Sky.—In clear weather, when the sun is high in the heavens, the sky, especially near the zenith, is of a deep-blue colour. The intensity of the blue depends largely on the size of the particles present. In warm anticyclonic weather, when the air is comparatively still and full of large dust particles, the blue becomes much less intense, whereas behind a depression, when the large dust particles have been washed out by the rain, the blue of the sky is often very intense.

This blue colour arises from the selective scattering of light by the dust particles present in the atmosphere. When a beam of light passes through a medium in which small particles are in suspension, and when the index of refraction of these particles differs from that of the medium, then the light is scattered in all directions. The atmosphere is such a medium, having dust particles in suspension in it. The particles are very minute, and thus selective scattering takes place. The rays of longer wave length, i.e. the red and the yellow, pass through the atmosphere,

therefore, with greater ease than do the blue and the green rays, which have a shorter wave length. So if the sky be viewed in a direction away from the sun the colour is a deep blue, while near the sun it is whitish. Near the horizon the blue colour is seldom so well marked, because of the greater thickness of the atmosphere traversed by the rays and the consequent increase of the number of dust particles met with.

Sunrise and Sunset Colours.—When the sun is near the horizon, the light from the sun has to pass through a much thicker layer of air, whereby the scattering of the blue rays becomes much more complete. The red and the orange alone are transmitted, and in this way the sun's disk appears red. As the intensity of the scattering depends on the number of particles present, the larger that number, the more marked will the red colour be. This effect is produced also by minute droplets of condensed water-vapour, and therefore the appearance of the sky at sunrise or sunset affords an indication of the amount of water-vapour present in this form in the lower layers of the atmosphere. Especially is this the case in the morning. At that time there are fewer dust particles present, as a rule, in the lower layers than in the evening, and thus a bright-red sky in the morning indicates the presence of many water-droplets.

The colour of the moon at rising and setting has the same explanation.

The first attempt at an explanation of the blue colour of the sky was made by Leonardo da Vinci, but it was not until 1871 that the real explanation was given by the late Lord Rayleigh. The explanation of sunrise and sunset colours naturally follows from that of the blue colour of the sky.

Twilight.—The phenomenon of twilight has already been referred to in Chapter II as a method for determining the height of the atmosphere. It is due to the reflection and the scattering of light by minute particles in the upper layers of the atmosphere.

Twilight lasts until the sun is 18° below the horizon, so that the reason for the difference in duration of twilight in different latitudes is at once apparent. In the neighbourhood of the Equator, where the sun sets practically perpendicularly to the horizon, the duration of twilight is short. It amounts to 1 hr. 13 min. on the average, being longest in January and July, 1 hr. 16 min., and shortest in the periods March–April and September–October, when it is only 1 hr. 10 min. In the polar regions it lasts several months. At the

North Pole, according to calculations by Laska, complete day reigns from 21st March until 23rd September; complete night from 14th November until the end of January; the intervals between those two periods are occupied by twilight.

The following table illustrates the duration of twilight in different latitudes:

TABLE XXVIII

DURATION OF TWILIGHT FOR THE FIRST DAY OF THE MONTH

Latitude.	January.	April.	July.	October.
0°	1 hr. 16 min.	1 hr. 10 min.	1 hr. 16 min.	1 hr. 10 min.
20°	1 hr. 20 min.	1 hr. 15 min.	1 hr. 25 min.	1 hr. 14 min.
40°	1 hr. 39 min.	1 hr. 34 min.	2 hr. 4 min.	1 hr. 32 min.
60°	2 hr. 48 min.	2 hr. 41 min.	—	2 hr. 25 min.

The blank space in the third column indicates that complete darkness does not take place on 1st July in latitude 60° N., or that on that date the sun is never 18° below the horizon.

The various phenomena accompanying twilight may be divided into two sets, a first set and a second set.

(a) In the first set are included: (1) the counter-twilight effect in the east when the sun is setting, and in the west when the sun is rising; (2) an effect which appears as a bright, whitish spot above the sun when he is setting, but while he is still above the horizon; this spot sinks towards the horizon as the sun sinks, and, as the sun disappears, broadens out, forming a bright line between the blue of the sky and the yellow horizon; (3) the first twilight arch; (4) the first purple light.

(b) The second set include: (1) the second counter-twilight; (2) the second twilight arch; (3) the second purple light. At sunrise all these effects occur in the inverse order, the second set preceding the first.

A full description of these various phenomena, together with their explanation, has been given by Pernter and Exner. Here we shall confine ourselves to a short account of the two purple lights.

The First Purple Light.—The phenomenon was first observed by Necker, and by him was given the name "vapeurs rouges". Since then it has been closely studied by many observers. Among the first of these was Von Bezold, who found that the first purple light of the evening was brightest when the sun was 4° or 5° below

the horizon. Thereafter it broadened out along the horizon, and finally disappeared. Average values indicate that the first purple light begins when the sun is about 3.2° below the horizon. It is then almost semicircular in shape. Maximum brightness is reached with the sun 4.2° below the horizon. Thereafter it broadens out, becomes fainter, and finally disappears when the sun has sunk 6.2° below the horizon. Plate XX (b) represents the first purple light.

For the second purple light the corresponding values are 7° , 9° , and 11° to 12° .

The Cause of the Purple Light.—The purple light is due to diffraction. Every ray of light coming from the western sky after the sun has set has to pass through thick layers of air, and as the

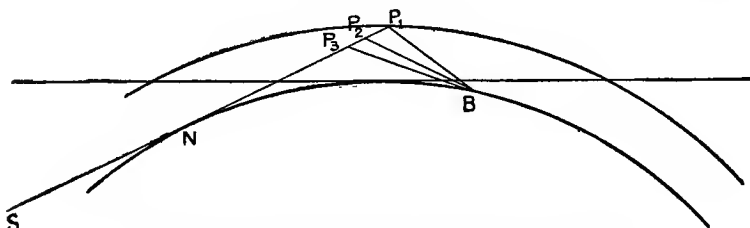

Fig. 96.—Diagram illustrating the Cause of the First Purple Light

rays of short wave-length are more or less cut out, the light reaching the eye is mainly red in colour, like the rays from the setting sun. But the larger particles of dust, &c., suspended in the air cause less diffraction than do the smaller, and also these larger particles are nearer the earth than the lighter and smaller. Consider, then, the path of the light as shown in fig. 96, and the manner in which the rays are diffracted by the particles.

The inner curve represents the surface of the earth, and the outer the upper limit of the atmosphere. Suppose that SP_1 is a ray of light from the sun meeting the atmosphere in the points P_1 , P_2 , P_3 . As the particles at P_3 are larger than those at P_2 , and those at P_2 larger than those at P_1 , the light will be less diffracted at P_3 than at P_1 , and so light from these three points will reach the observer's eye at B. The effect of these various rays is to produce the purple light. The farther the sun sinks the greater the part played by the rays from the sun nearest the surface in forming the purple light as seen by the observer at B. The phenomenon thereby will become more intensely red for a time, but by further sinking of the sun the diffracted rays will gradually rise and pass above the observer's head,



a. Zodiacal Light



b. Purple Light

so that the effect becomes fainter, and the arch sinks gradually below the horizon.

The Second Purple Light.—This is in all probability caused by reflection from the first purple light in exactly the same way as the first purple light is caused by the direct rays of the sun. The concentration of the rays is again dependent on the arrangement of the dust particles in the atmosphere.

Fig. 97 represents how the second purple light arises from the first. The ray of light from the sun S is diffracted in the neighbourhood of P, and the diffracted ray passes in the direction of PP'. Further diffraction takes place in this direction, and the observer at B sees in consequence the second purple light. This explains why

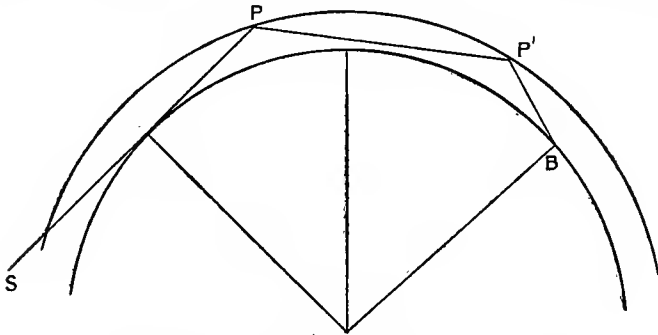

Fig. 97.—Diagram illustrating the Cause of the Second Purple Light

the second purple light appears when the sun is approximately twice as far below the horizon as he is when the first appears.

The Zodiacal Light.—This phenomenon is almost confined to the region of the tropics, but it is occasionally seen in mean latitudes. It is probably due to diffused sunlight scattered by fine particles of dust, or small bodies revolving round the sun. It appears as a faint pyramid of light rising above the horizon. It is most easily seen in the evening in spring, and in the morning in autumn, because at these times the angle between the plane of the zodiac and the horizon is greatest. On clear moonless nights it is very often visible in the south of England at the proper seasons. The light is really elliptical in form, with the sun in the centre and the principal axis lying along the ecliptic. The outside of the ellipse is very badly defined, the light fading off gradually on all sides. Plate XX (*a*) represents the phenomenon as seen in mean latitudes.

CHAPTER XI

Atmospheric Acoustics

Sound.—When a plate or a rod, clamped at one end, is struck, it is set in vibration. The same takes place when a string stretched between two points is plucked, the vibrations being visible to the eye. But the brain may become aware of these vibrations, not only through the sense of sight, but also through the sense of hearing. The sensation received through the ear, and also the external disturbance which causes that sensation, are both denoted in common language as sound. For the present, however, we shall concern ourselves only with the external disturbance, the method in which it arises, and its propagation through the atmosphere.

Sources of Sound.—Sound arises in general from a vibrating body. This body may be a rod or a stretched string which, when plucked or struck, vibrates, and these vibrations are communicated to the air. On the other hand, the source of sound may be a column or mass of air itself. The vibrations from these sources are then communicated through the air to the ear.

An Elastic Medium Necessary.—For the propagation of sound some elastic medium, such as air, is necessary, as may easily be demonstrated in the following way. If a bell be placed under the receiver of an air-pump, and struck while the receiver is full of air, the sound of the bell can easily be heard. But if the receiver be gradually exhausted, the sound of the bell becomes fainter and fainter as the exhaustion proceeds. Perfect silence will not be obtained as the support of the bell is in contact with the receiver, and some of the sound is conveyed to the outer air through the material of the support and the receiver.

Propagation of Sound in a Uniform Medium: VELOCITY.—When a sound originates in a medium such as air, the vibrating body causes a number of compressions and rarefactions of the air, so that a series of waves is established in the medium. This wave

motion travels out from the source with equal velocity in all directions provided the medium is uniform, the velocity depending on the density and elasticity of the medium. Newton arrived at the conclusion that the velocity of sound in air or any gas could be expressed by the formula

$$v = \sqrt{P/D},$$

where P is the normal atmospheric pressure and D the density of the gas. But this conclusion was arrived at on the assumption that no heating or cooling of the gas took place on compression or expansion. Now, adiabatic heating and cooling of the gas does take place, and so Newton's formula was modified by Laplace. The true expression for the velocity of sound in a gas is given by

$$v = \sqrt{\gamma P/D},$$

where $\gamma = 1.41$, and is the ratio of the two specific heats of air. This gives, as the velocity of sound in air at 273° A., 332.2 m., or 1090 ft. per second. This velocity increases .61 m., or 2 ft. per second, for every degree rise of temperature above 273° A., and therefore the velocity at 283° A. is 338.3 m., or 1110 ft. per second. In warm air, therefore, sound travels more quickly than in cold air, a fact which is of great importance to sound-rangers.

Reflection of Sound.—As sound is propagated by wave motion, it can be reflected, the sound waves being reflected just as water waves are. This reflection of sound waves is the cause of echoes. The phenomenon of echoes is particularly noticeable in mountainous districts, the mountain sides reflecting the sound waves again and again. Reflection is also produced by clouds and by the dividing surface between two layers of air of different density. The rolling of thunder is to a small extent due to this reflection of the sound waves within the thunder-clouds.

Refraction of Sound: EFFECT OF WIND.—If the air were still and homogeneous, then the sound waves would travel with equal velocity in all directions from the source. But it is a well-known fact that sound carries better with the wind than against it. The velocity in any particular direction is compounded of the velocity of the sound in still air and the component of the wind's velocity in that particular direction. Now the velocity of the wind increases from the surface upwards, and thus on the windward side of a source the sound wave travels more quickly near the ground than

overhead. This causes the wave-front to bend upwards, or the sound is refracted upwards, and to an observer placed sufficiently far on the windward side of the source, no sound is audible as the sound wave passes over his head. On the other hand, on the lee side of the source the sound travels more quickly overhead than on the surface. The wave-front is thus kept near the surface of the earth, so that an observer on the lee side hears the sound when it is quite inaudible to an observer on the windward side at an equal distance from the source.

EFFECT OF TEMPERATURE GRADIENT.—Refraction of sound also arises through the variation of temperature with height. Temperature, as a rule, decreases with height, especially in the day-time, though the fall in the neighbourhood of the ground is generally irregular. The greatest velocity of sound is therefore experienced near the ground, and in this way the sound wave is refracted upwards. If the temperature increases with height, i.e. if an inversion takes place, as it often does, after sunset, then the sound wave travels more quickly above than close to the surface. The sound is in this way concentrated along the surface, whereby reports can be heard close to the ground at a much greater distance than under normal conditions.

A combination of reflection and refraction of sound waves takes place on a hot day in summer. On such a day convection currents are active and the air is no longer homogeneous, cold and warm layers of air often being in juxtaposition. The sound waves are thereby partially reflected in passing from one layer to another. In this way the waves become broken up, and the sounds carry only comparatively short distances.

THUNDER

When an electric discharge takes place through air, the air is heated and expands, and a compression wave is started, and travels through the air. If an observer be near the discharge, he hears a single snap. An example of this is afforded in a single discharge from an induction coil. In a lightning discharge, if the flash be short and the observer near the point where the discharge takes place, a short crash is heard. But if the flash extends to a considerable length, then the sound wave from the nearer end reaches the observer much sooner than that from the farther end, so that

the report is much longer. This partially explains the rolling of thunder. But the sound waves also undergo reflection from such objects as mountain sides, clouds, and surfaces between air layers of different density, and therefore to the original thunder crash there is added the echoes arising from these different sources. This affords an explanation of why thunderstorms appear to be accompanied by so much more noise in mountainous regions than over open plains.

Effect of a Heterogeneous State of the Atmosphere.—The sound of a thunderclap carries, as a rule, only a comparatively short distance. An explanation of this is found in the heterogeneous state of the atmosphere during a thunderstorm. Large masses of cold air descending find themselves in close proximity to warmer ascending masses, and in this way the sound waves become broken up, and consequently the sound carries a less distance than under normal conditions.

Distance of a Lightning Discharge.—The distance that a lightning discharge is from an observer can easily be calculated. Light travels practically instantaneously, and sound at the rate of 1090 ft. per second at 273° A. Therefore by counting the seconds between the instant the flash is seen and that on which the first sound of the thunder is heard, and multiplying this number by $(1090 + 2t)$, where t is the mean temperature of the air at the time expressed in degrees centigrade, the observer obtains the distance in feet. A fairly close approximation is obtained by assuming that at ordinary temperatures sound travels at the rate of 1 mile every 5 seconds.

Sounds in a Fog.—We have seen that when a fog forms there is always an inversion of temperature. Under these conditions the sound wave is compelled to travel near the surface of the earth, and so in a fog sound carries farther than in clear weather. Also the layers of air in which the fog forms exhibit a more uniform temperature than under normal conditions, and the waves are not broken up by reflection. Both of these factors, therefore, enable sounds to be heard farther from the source in fog than in clear weather.

As this is the case, the reflection of sound waves by clouds arises not from the particles of water which form the clouds, but from the fact that within the clouds are found air layers at different temperatures.

Sound Ranging.—A very important application of the propa-

gation of sound waves through air has been found in sound ranging. The velocity of sound in still air at any given temperature is known, and thus if the velocity of the wind and the temperature of the air in the various layers through which the sound wave travels are known, the velocity in any particular layer can be found. Hence the path of the sound wave can be deduced, and this path resembles a parabola in its general form. The velocity of sound in this path is found to be the velocity of sound in still air, together with the component velocity of the wind in the plane which contains the normal to the sound wave at one-third the height of the vertex of the ray above the earth's surface.¹

In this way the time taken by a sound wave to travel a given distance in a given direction can be determined, provided information regarding the temperature and wind values in the different layers is available.

Location of a Source of Sound.—If, then, a series of listening-posts be arranged in the neighbourhood of a big gun, and the times

of arrival of the sound waves produced by the firing of the gun noted at the different posts, the position of the gun can be determined. In fig. 98 let G represent the position of the gun, and A, B, C the positions of three listening-posts, such that the intervals of time between the arrival of the sound at A and B and A and C are t_1 and t_2 respectively. Describe circles round B and C as centres, and with radii Vt_1 and Vt_2 respectively, where V is the velocity of the sound wave. If another circle be described passing through A and touching the other two externally, the centre of this circle will be the position of the gun.

If, in place of circles, hyperbolas be described on AB and AC, then the intersection of corresponding branches will also give the gun position. But in the neighbourhood of the gun, as the position

¹Green: "The Propagation of Sound in the Atmosphere", *Quar. Jour. Roy. Met. Soc.*, Vol. XLV, p. 346.

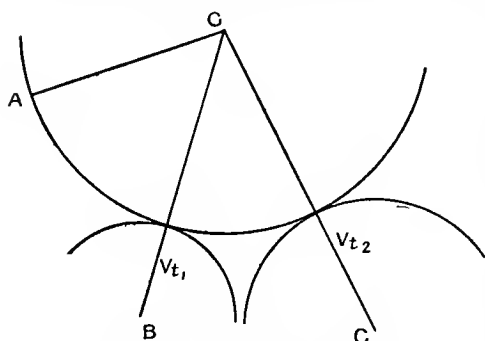

Fig. 98.—Location of a Source of Sound

of the intersection of the asymptotes differs but little from that of the hyperbolas, the intersection of the asymptotes may be used without much error. In actual practice this is the method adopted.

Recording the Time Intervals.—The most essential thing is the recording of the time interval. For this purpose microphones are fixed one at each listening-post, and from there they are connected to an Einthoven galvanometer at a central position. In practice an arrangement on the lines shown in fig. 99 is used. Six

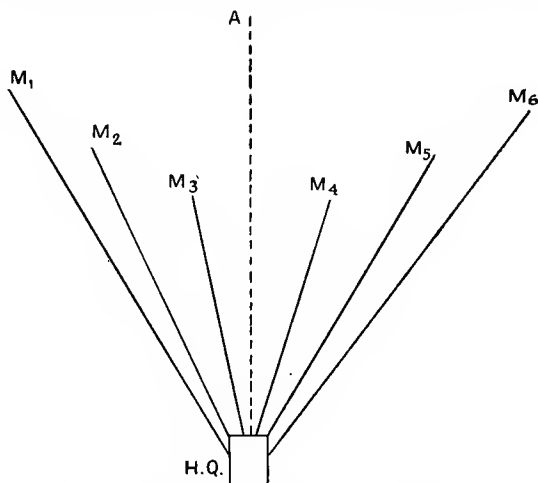

Fig. 99.—Arrangement of Microphones in Sound-ranging

A, Advanced post. M₁–M₆, Microphones. H.Q., Head-quarters.

microphones are arranged along a part of the front in accurately surveyed positions at a distance of about 3000 yd. behind the front line, and covering a front of about 9000 yd. In front of the line of microphones is an advanced observation post, and this post and the microphones are all connected to head-quarters. At head-quarters is the recording apparatus, consisting essentially of an Einthoven galvanometer with six strings, each connected to one microphone. This arrangement is known as the "harp". The current from each microphone causes the corresponding string to vibrate, and this vibration is recorded photographically by means of a kinematograph film. Time intervals are marked on the film every hundredth of a second by interrupting the light, so that the

difference in time of arrival of the sound at two stations can be calculated to the hundredth of a second easily.

The apparatus at head-quarters is controlled by an observer in the advanced observation post. When he hears the report of a gun, he presses a key, the apparatus is set in motion, and all is ready to record the sound when it reaches the microphones. When the observer considers that the sound wave has passed over all the microphones he releases the key and the apparatus stops. The film is then developed, fixed, and dried very rapidly, and from the readings the position of the gun can be located in from 4 to 10 minutes after it has fired. The microphone used in sound-ranging must be sensitive to sounds of long wave-length, such as occur in the report of a big gun, but comparatively insensitive to sounds of short wave-length like those of rifle fire.

As the microphone is situated on the ground and is affected only when the sound wave passes over it, it is very difficult to obtain records when the source of sound is to the leeward of the microphone, for reasons already explained.

Audibility of Distant Gunfire.—Another interesting problem, which was discussed at some length during the recent war, is the sound of distant gunfire. The sound of gunfire on the Continent was repeatedly heard in south-east England. Mr. Miller Christy has communicated several papers to the *Quarterly Journal of the Royal Meteorological Society* on the subject. In one of these¹ he gives the periods of audibility during the four years 1915–8, showing that these periods cover practically the same time of year in each case, viz. from the beginning of May until the end of August.

When a large explosion takes place, there is an area surrounding the point in which the sound is heard at all points. Encircling this region is another at all points in which no sound is heard. This region is known as a zone of silence. Beyond this zone of silence lies another region in which the sound is again heard.

The question of audibility of distant gunfire turns therefore on the question of the conditions suitable for the propagation of sound in the upper atmosphere in a particular direction. This in turn apparently depends on the vertical temperature gradient and on the wind structure.² Gunfire on the Continent was best heard in

¹ *Quar. Jour. Roy. Met. Soc.* Vol. XXV, pp. 141–146.

² The problem has been dealt with at great length by S. Fujiwhara in the *Bulletin of the Central Observatory, Tokyo*, Vol. II, No. 1 and No. 4.

south-east England during the summer months. On the other hand, it was best heard over western Germany in the winter months. This indicates a seasonal variation in the direction of the outer zones of sound, and so far no mathematical explanation of this variation has been given. The general air-current in the troposphere and also within the stratosphere up to heights hitherto observed is from west to east. Whipple¹ has suggested that at still greater heights there may be a monsoon effect which may explain the phenomenon. Further observation is necessary, however, before definite conclusions can be arrived at.

¹ "Variation in Audibility of Distant Gunfire", *Quar. Jour. Roy. Met. Soc.*, Vol. XLV, p. 286.

CHAPTER XII

Weather Forecasting and Climate

A.—WEATHER FORECASTING

The weather at any particular time in any given place is defined when the meteorological elements have values assigned to them, i.e. when the condition of the atmosphere as regards temperature, pressure, wind, humidity, cloud, and precipitation is known. For successful forecasting of weather the forecaster must be in a position to say, from information available to him, what changes are likely to take place within a certain time, as regards these various elements.

Information Necessary.—The first essential for the forecaster is that the amount of information at his disposal be as complete and as accurate as possible. Such information may be divided into two branches, (*a*) information regarding the normal conditions prevailing in the region for which the forecast is intended, and (*b*) detailed information regarding the condition of the meteorological elements at a particular hour in that region.

Normal Conditions.—The average conditions in any region may be arrived at from a study of the geographical position of the region, of the general circulation of the atmosphere, of the ocean currents, but mainly from observations taken over a considerable period of time at stations distributed over the area in question. Information of this type has been dealt with in the preceding chapters, and the general characteristics of the different regions of the globe considered. A study of the average conditions places the forecaster in a position from which he is able to obtain ideas regarding the general type of weather to be expected in any region during a particular season of the year.

Particular Conditions.—But though a forecaster may possess much information about average conditions in any country, this will not suffice, for the weather on the same day in two or more successive years is by no means necessarily the same. It is almost

entirely dependent on the distribution of high- and low-pressure centres in the neighbourhood of the region at the time, and on the nature and extent of these highs and lows. Detailed information regarding the various meteorological elements within these pressure distributions must therefore be obtained, and all this information must refer to some particular hour of the day. For this purpose a large number of stations in direct telegraphic or telephonic communication with a central office must be scattered regularly over the area from which these observations are required.

Organization Necessary: STATIONS.—In the British meteorological service these stations are divided into three groups, first order stations, second order stations, and third order stations.

At stations of the first order continuous records, or hourly readings of pressure, temperature, wind, sunshine, and rainfall, together with cloud observations at fixed hours, and notes on the weather, are made. At stations of the second order observations are made at least twice daily of pressure, temperature, wind, cloud, and weather, maximum and minimum temperature, and once daily of rainfall, and in some cases sunshine. At third order stations observations are of the same kind as at second order stations, but are less full or are taken only once a day or taken at hours other than the recognized hours.

In addition to the observations mentioned above, the velocity and direction of the wind in the various upper layers of the atmosphere are determined by means of pilot balloons when weather conditions permit, at stations of the first order and also at some second order stations. Observations of temperature in the free atmosphere are made at a few special stations by means of aeroplanes.

Telegraphic Reports.—From stations of the first order and also from many of the second, information giving the exact values of pressure, temperature, wind direction and velocity, humidity, visibility, cloud direction and velocity, cloud amount and type, at 7 h., 13 h., and 18 h., together with a brief synopsis of the weather since last observation, is telegraphed to the central office in London as soon after the hour of observation as the telegram can be prepared. In many cases a fourth set of readings is taken at 1 h. and the information dispatched as soon thereafter as possible. These telegrams are compiled from eye observations, and in order to make them as short as possible a special code is used for the

purpose. When the telegrams reach the London office they are at once deciphered and the values of the different meteorological elements inserted on a chart of the area. In this way the state of the weather over the whole of the British Isles at a given hour is known at the central office generally within an hour of the time the observations are made. From this information a synchronous chart is prepared which enables the forecaster to see at a glance the distribution of the various meteorological elements at the hour of observation.

Synoptic Charts, their Composition and Use in Forecasting.

—These charts are generally called synoptic charts, and the principal method of forecasting weather at the present day is by means of these synoptic charts. The introduction of the method has already been referred to in Chapter VII, and need not be recapitulated here. The area covered by these charts is wider than the district or region for which the forecast is intended, as the forecaster must have information regarding the values of the meteorological elements in regions outside his own particular area. Therefore not only are observations taken within the area of the British Isles required in forecasting for any region of the British Isles, but also observations from outside the area. To complete the synoptic chart, observations are received from the countries of western Europe, Spain, France, the Netherlands, Germany, Denmark, Scandinavia, north-western Russia, Iceland and the Faroe Islands, and also from the Azores. By international agreement all observations are made in this area at the same Greenwich mean time, in order that the observations may be comparable. Additional information is also received by wireless from ships on the Atlantic, thereby completing the circle round the British Isles.

Pressure, Tendency, and Characteristic.—From the readings of pressure recorded in millibars on the chart, the isobars can be drawn, showing thereby the distribution of pressure over the area at the hour of observation. This distribution does not represent the pressure values as actually read, as all values are first reduced to a common level, viz. sea-level in the case of western Europe, and therefore it is the distribution that would hold were the whole country at mean sea-level.

Besides the actual pressure, there is recorded on the chart the change in pressure during the last three hours before the time of observation. This is called the "tendency of the barometer", and

is measured not in millibars but in half-millibars. Along with the tendency there is charted a symbol indicating the nature of the tendency. This symbol is called the "characteristic of the tendency". The tendency and its characteristic are very important from the point of view of the forecaster, in many cases being even more important than the actual pressure. They afford one of the best guides in determining the direction of motion of the pressure distribution existing on the chart, and often give the first indication of a new system approaching from a region beyond the limits of the chart.

As a rule the pressure distribution, together with its tendencies, and characteristics, is of greater importance in a country like the British Isles, where depressions arrive from the Atlantic fully developed, than in continental areas where the pressure distribution is generally more irregular.

Temperature.—The next consideration is the temperature distribution. It is almost always much more irregular than that of the pressure, and as a rule plays a smaller part. Temperature values are not reduced to a common level in the way pressure values are. Even if they were reduced to some common level, there are other influences, such as inland and coastal conditions, which could not be easily allowed for in any method of correcting individual values. But in some cases temperature values are exceedingly important. If a marked difference in temperature is found between the current in front of the trough of a depression and that behind the trough, then in the neighbourhood of the junction of these currents there is a considerable risk of a line squall, and this the forecaster has ever to be on the outlook for.

A comparison between the temperatures of the chart under consideration and those of the corresponding chart of the previous day or days is often of great assistance, as it shows the general tendency of the temperature, indicating whether values are increasing or decreasing on the whole. These temperature changes are of more importance over continental areas than over coastal regions, often serving as an indication of the direction in which a system is to move. Thus it is often found that a low-pressure system moves in the direction in which has taken place the greatest rise in temperature. On British synoptic charts temperature values are still recorded in degrees Fahrenheit.

Wind.—Pressure and temperature are both charted by numbers indicating their numerical values. But in charting wind values

an arrow is used to denote the direction of the wind at the station, while the strength of the wind on the Beaufort scale is denoted by the number of *flèches* on the arrow. In a well-developed cyclone the wind distribution is on the whole regular, and its values, both as regards direction and velocity, are in accordance with the pressure distribution. The forecaster must, therefore, be on the outlook for apparent irregularities in the wind values. If the wind direction at a particular point on his chart does not appear to be in accordance with the isobars as drawn, then in all probability the isobars are wrongly drawn, and instead of being smooth curves should be represented by sinuous curves. These sinuosities in the isobars demand close attention, as often they have bad weather associated with them. Further, they may be the first indication of the development of a secondary depression.

Weather at Time of Observation.—The state of the sky as regards cloud amount, or the condition of the weather as regards rain, snow, mist, frost, thunderstorms, or any other phenomenon at the time of observation, is recorded on the chart according to the following convention based on the notation used by Admiral Beaufort:

<i>b.</i>	Blue sky, not more than one quarter clouded.		
<i>bc.</i>	Sky not more than half clouded.		
<i>c.</i>	Sky " " " three-quarters clouded.		
<i>o.</i>	Sky completely overcast, or not more than one-tenth visible.		
<i>y.</i>	Dry air: relative humidity below 60 per cent.		
<i>e.</i>	Wet air without rain falling.		
<i>f.</i>	Fog.	International symbol =	≡
<i>fe.</i>	Wet fog.	" "	= ≡≡≡
<i>m.</i>	Mist.	" "	= ≡≡≡
<i>z.</i>	Dust haze.	" "	= ∞
<i>w.</i>	Dew.	" "	= ∇
<i>x.</i>	Hoar frost.	" "	= †
<i>g.</i>	Gloom.		
<i>u.</i>	Ugly, threatening appearance of the sky.		
<i>v.</i>	Unusual transparency of the atmosphere.		
<i>d.</i>	Drizzling rain.	International symbol =	••
<i>r.</i>	Continuous rain.	" "	= •
<i>p.</i>	Passing showers.		
<i>s.</i>	Snow.	" "	= ✕
<i>h.</i>	Hail.	" "	= ▲
<i>q.</i>	Squalls.		
<i>l.</i>	Lightning.	" "	= ζ
<i>t.</i>	Thunder.	" "	= T
<i>tlr.</i>	Thunderstorm.	" "	= ⚡

Instead of the letters the international symbols may be used. These symbols are given in the table where possible. This enables the weather conditions over the whole area to be seen at a glance. Not only is the present weather charted, but also the "past weather" from the time of the previous chart, whereby the forecaster has in front of him a sequence of the weather at each station.

Besides the information detailed above, there is also available to the forecaster information regarding the amount of precipitation at each of the various stations during the last twenty-four hours, at least for the 7 h. chart. Likewise results of pilot balloon soundings from a limited number of stations are available at certain hours, and some temperature soundings of the upper atmosphere.

This gives in brief the information regarding existing weather conditions available to the forecaster.

From experience it is found that, in a general way, the weather associated with a depression moves with that depression. This is not strictly true; for, if it were, forecasting would reduce itself to determining the direction in which a depression was to move. But as the depression moves the values of the meteorological elements within it change also. The forecaster therefore has at least three points to consider: (1) how the pressure systems on the chart will move; (2) what changes are likely to take place within these systems; and (3) what effect these changes will have on the weather conditions within the systems.

The Direction of Motion.—The general direction of motion of cyclones in our latitudes is from west-south-west to east-north-east, but each particular case must be dealt with on its own merits. The first consideration of the forecaster, therefore, is to consider in what direction the pressure is falling most rapidly, i.e. what the barometric tendencies at the various stations are. In conjunction with the tendency he has got to consider also its characteristics, in order to ascertain whether the fall in a given direction is still continuing at the hour of observation, or whether it has been checked. In this way the characteristic is of great assistance in indicating the direction in which a depression is likely to move, while the tendency affords an idea of the rate at which the centre of the system is moving.

The direction of motion of anticyclones is generally much less definite and the velocity of translation smaller, the pressure changes being less regular than in the case of the cyclone. But here also

the characteristics and tendencies serve to indicate the direction of motion.

Guilbert's Rules.—Another feature which aids the forecaster in determining the direction of motion of a cyclone is the direction and velocities of the winds within it. This feature has been closely studied by M. Gabriel Guilbert, and as a result he has formulated certain rules,¹ which have been summarized by Shaw in the following way ²:—

“A.—*As regards Strength of Wind.*”

“1. A depression with winds above normal on all sides will sooner or later fill up; one with winds below normal will become deeper, and often depressions which are apparently weak will change into cyclonic storms.

“2. Those parts of a depression in which the winds are below normal indicate directions in which the depression may advance; thus, when a depression consists partly of winds that are above normal and partly of winds that are below normal it will move in the direction of ‘least resistance’, that is, in the direction where the winds are below normal.

“3. Pressure increases from right to left across the line of winds too strong for the gradient. Such winds cause an increase of pressure on their left as they move.

“B.—*As regards Direction, Divergent and Convergent Winds.*”

“1. Winds are divergent from the normal direction if they blow away from a low-pressure area or in opposition to the normal direction corresponding with the isobars. A wind below the normal for its gradient is divergent in respect of the component, which must be superposed upon the normal wind to give the actual wind.

“Divergent winds indicate the approach of a low-pressure system.

“2. Winds are convergent if they blow more directly towards a low-pressure area than a normal wind. A wind which exceeds the normal is convergent in respect of the component, which must be added to the normal to give the actual wind.

“Convergent winds indicate the departure of a low-pressure system or a rise of pressure.”

¹ *Nouvelle Méthode de prévision du Temps*, par Gabriel Guilbert, 1909.

² Shaw: *Forecasting Weather*, p. 319.

The value of the normal wind chosen by Guilbert is about 45 per cent of the gradient wind, while the direction of the wind is regarded as abnormal if the direction is greater than 40° from the direction of the isobars.

Precautions against apparent Abnormal Winds.—These various points enable the forecaster to determine the most probable direction of motion of any cyclone present on his chart, and at the same time indicate any developments which are likely to arise within the system. The apparent divergence of the wind from the normal direction at some particular point may arise from sinuosities in the isobars, and this may be the first indication of the development of a secondary depression. But great care must be exercised in drawing conclusions from winds which are apparently abnormal. If all stations had an equal exposure, then the problem would be much more simple; but each station has its own peculiarities, and the forecaster must become acquainted with all these peculiarities before he is in a position to say whether any wind is normal or abnormal for a given station. When, however, he has once become thoroughly familiar with the peculiarities of the various stations, a departure from these in a system otherwise normal should at once indicate to him that some change is likely to take place within the system.

Indications of an Approaching Depression.—Just as changes within a system present on the chart are indicated by some abnormality, so the approach of a depression from a region beyond the limits of the chart is indicated in the same way. A check in a rising barometer, a decrease of the wind, together with perhaps a slight rise in temperature, all tend to show the approach of a new disturbance. For this purpose also the appearance of the sky is a very important factor, while the motion of cirrus clouds is very often instrumental in indicating the direction from which a disturbance is likely to travel. Cirrus often appears in fine weather, but then its motion is extremely slow. If it is travelling at a high speed across the sky, it is almost invariably associated with a depression, and its velocity gives an indication of the velocity of translation, and also of the intensity of the approaching depression. In conjunction with cirrus observations, the velocity and the direction of the wind in the different layers of the atmosphere are of the greatest assistance to the forecaster. These values show the distribution of temperature in the upper layers, though they do not in

themselves give the absolute values of the temperature. If some temperature observations have been carried out over a few stations, then from the wind values the forecaster can form an idea of the temperature of the air within the approaching depression, whether that air is comparatively cold and the disturbance in consequence likely to bring much precipitation, or whether it is moderately warm and the amount of precipitation likely to be comparatively small.

General Forecast for any District.—With his chart completed and his mind made up as regards probable alterations and modifications of the pressure systems on the chart during a period of 12, 24, or 36 hours after the time of the chart, the forecaster is in a position to say what he considers the most probable weather will be in these periods over any district within the area of his chart. As the weather is entirely different in the different quadrants of a depression, the area in which one set of conditions prevails may be quite limited. This being so, the area of the British Isles for the purposes of forecasting has been divided into twenty districts. The following is a list of these districts:

1. South-east England.
2. East England.
3. East Midlands.
4. West Midlands.
5. South-west England.
6. South Wales.
7. North Wales.
8. North-west England.
9. North Midlands.
10. North-east England.
11. East Scotland.
12. South-west Scotland.
13. Isle of Man.
14. North and North-west Scotland.
15. Hebrides.
16. Orkney and Shetland Islands.
17. North-west Ireland.
18. North-east Ireland.
19. South-east Ireland.
20. South-west Ireland.

Benefit from a Detailed Study of Local Conditions.—For each

of these districts the forecaster in a central office is able to give a forecast of the general weather, but as each district has its own peculiarities much might be accomplished through a detailed study of local conditions undertaken by a local organization. This would enable the peculiarities under different conditions to be arrived at, and the general forecast considerably supplemented in consequence.

Forecasting of Gales.—One of the most important duties of an official forecaster is the forecasting of gales. He has not only to anticipate the velocity and direction of the wind in certain districts within the area of his chart, but he has also to send warnings to the storm-signal stations on the coasts likely to be affected. This service was introduced about sixty years ago by the Board of Trade, at the suggestion of Admiral Fitzroy, who was in charge of the Meteorological Department at the time.

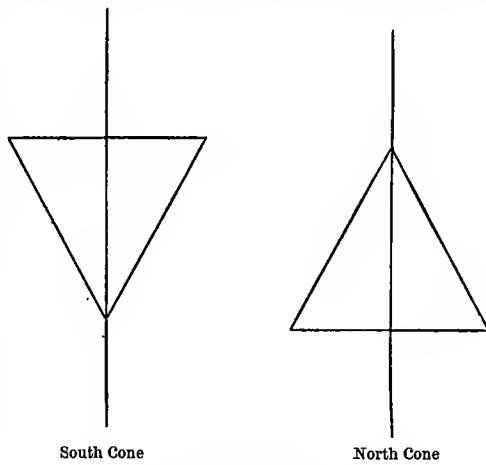

Fig. 100.—Storm Signals

The signals used were a cone and a drum. Some modifications have taken place in the original arrangement since that time, and at the present day the drum is no longer used. The duration of the warning is thirty-six hours if the warning is based on a morning chart, and twenty-four hours for one based on an evening chart. When the ports and fishing-stations to which these warnings are issued receive notification of an approaching gale, a cone, 3 ft. high and 3 ft. wide at the base, and painted black, is hoisted. If the gale is expected from the south then the cone is hoisted with point downwards, if from the north the cone is hoisted vertex upwards (see fig. 100). At night-time instead of the cones the signals consist of three lanterns, hung on a triangular frame, point downwards for a south gale, point upwards for a north gale.

Under the term "south" are officially included gales and strong winds:

- "(1) from south-east, veering to south-west, west, or north-west;
- (2) from south-west, veering to west or north-west;
- (3) from west, veering to north-west; and
- (4) from east, veering to south or south-west".

Under the term "north" are officially included gales and strong winds:

- "(1) from south-east, east, or north-east, backing to north;
- (2) from north-west, veering to north, north-east, or east;
- (3) from north, veering to north-east or east; and
- (4) from north-east, veering to east".

Southerly Gales.—Southerly gales are due to depressions arriving from the Atlantic, in which the gradient is steep. When the forecaster finds that pressure is giving way rapidly on the west coast of Ireland with the wind between south-east and south and below normal, he may anticipate a gale from the south on all the western coasts, and perhaps also along the Channel. The extent of the region affected depends on the development of the depression. In order to watch this development more closely the forecaster may call for a Special Chart.

"Special" Charts.—These charts are compiled from observations taken at an hour different from any of the standard hours. Thus if the 7 h. chart shows a rapid fall of pressure in the extreme west, a 10 h. chart will be called for by telegrams sent from the central office to the observing stations concerned. In this way the forecaster can follow the progress of the disturbance, and can determine which districts in his area ought to receive warning of its approach.

Effect of Secondary Depressions.—Often secondary depressions develop on the southern side of deep cyclonic depressions, and the gradients in these become superposed on those of the original depression. As a result, the wind on the northern side of the secondary centre may fall away almost to a calm, whereas on the southern side it becomes considerably augmented. In this way, at two stations only a comparatively small distance apart, the wind velocity may be absolutely different, though from the original appearance of the depression a gale of equal violence was anticipated at both

stations. Again, the development of a secondary in a depression may result in a gale which otherwise would not have occurred, so that in gale warning, just as in ordinary forecasting, the forecaster must ever be on the outlook for the development of secondaries, which exaggerate the gradients over certain areas.

Northerly Gales.—Northerly and easterly gales over the British Isles are due to deep depressions passing up the Channel. The current on the northern side of the centre of the depression is a cold one, and is often accompanied by snow or sleet. An example of a gale of this type is seen in the storm of 11th to 13th November, 1915 (see figs. 75, 76, pp. 218, 219).

TYPES OF WEATHER

Anyone who has handled synoptic charts for any length of time soon begins to find that though no two charts appear identically the same, yet there are many charts which bear a strong resemblance to one another. This being so, he begins to group his charts, dividing the weather associated with them into various types.

Abercromby's Weather Types.—Abercromby in his grouping gives four types of weather—the southerly, the westerly, the northerly, and the easterly. To these Shaw in *Forecasting Weather* adds a south-westerly type and a north-easterly type, because these types are very common over the British Isles. These various types are all determined by the positions of the areas of permanent high pressure, and the weather conditions experienced in the southerly to westerly types are associated in general with depressions moving along the borders of these high-pressure areas. Another type occurs when an area of high pressure is centred over the British Isles, and the winds in consequence are light and variable. Such a type may be styled an anticyclonic type.

A larger number of types might easily be suggested, but to the beginner these seven types will serve as a starting-point, for in them is included the majority of the weather conditions experienced in the British Isles.

The Southerly Type.—This type is most common in the cold season, for at that time there is a large area of high pressure stretching across Asia and Europe. When this area of high pressure spreads westwards so as almost to reach the British

Isles, then lows approaching from the Atlantic move northwards along its western borders. If the southerly current has its origin in the south-west, and is in consequence mild, the type is generally short-lived, the mild southerly current being replaced by a colder westerly one. An example of the southerly type changing to

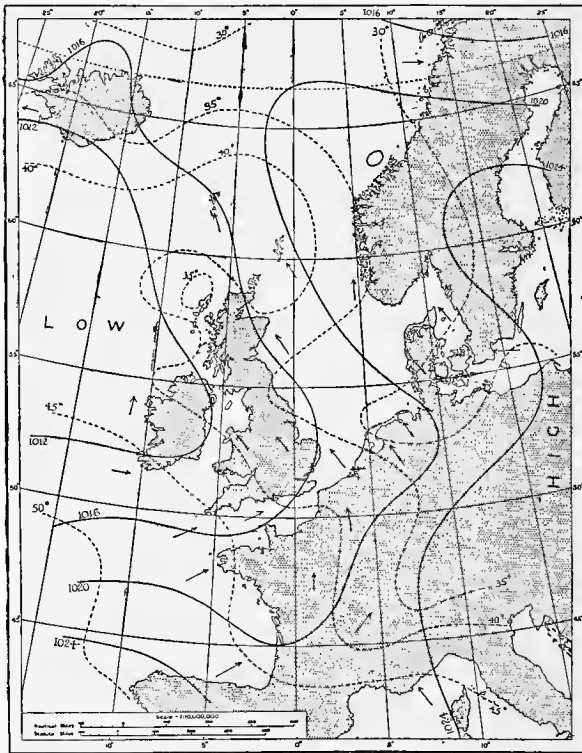

Fig. 101a.—Southerly type, changing to a south-westerly type, showing pressure and temperature distributions. Pressure expressed in millibars, and temperature in degrees F. (7 h. chart for 17th February, 1917.)

a westerly type is given in fig. 101 (a). It indicates the conditions at 7 h. on 17th February, 1917.

If, on the other hand, the southerly current over these islands comes from the south-east, and so belongs to the circulation round the anticyclone over the Continent, then it is a cold current, and the type may persist for quite a considerable period. A current of this type is more often experienced on the east coast than on the west.

The Westerly Type.—In this type the permanent high-pressure area over the Atlantic has receded, and has its centre situated south of the Azores. Along the northern side of this high-pressure area prevails a strong westerly current often stretching right across the Atlantic. On its northern edge is found

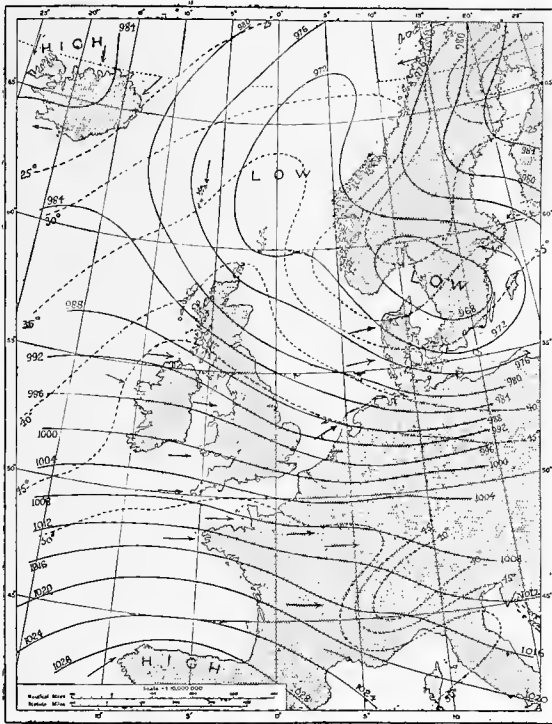

Fig. 1016.—Westerly type, showing pressure and temperature distributions. Pressure expressed in millibars, temperature in degrees F. (7 h. chart, 12th January, 1920.)

a series of depressions following one another from west to east. These depressions pass across our islands and on towards the Continent, causing much unsettled weather, with heavy winds often reaching gale force, and much cloud and precipitation. The temperature on the southern side remains fairly high, but on the northern side it is apt to fluctuate considerably, as the westerly current is often inundated by cold northerly currents sweeping in behind the depressions. This unsettled westerly type is most

frequently experienced in winter, as during that period the permanent high over the Atlantic has receded southwards. The type is generally persistent, lasting sometimes for weeks on end. An example of the type is shown in fig. 101 (b), which represents the conditions at 7 h. on 12th January, 1920.

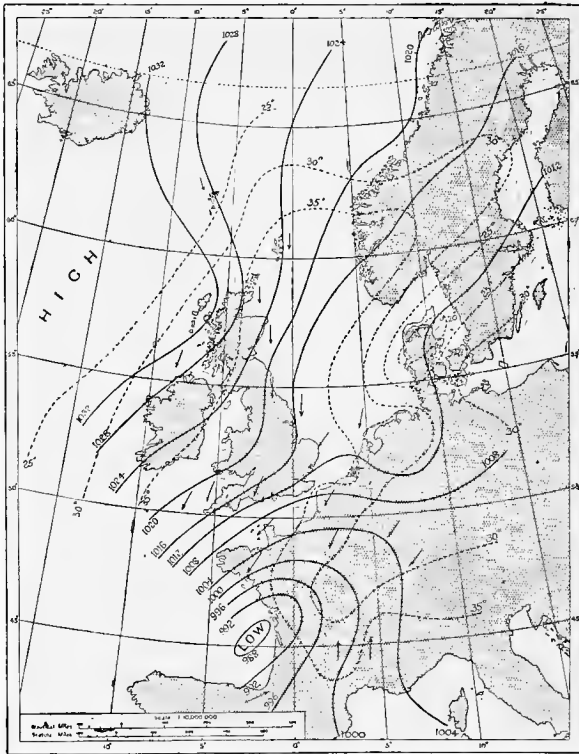

Fig. 102a.—Northerly type, showing pressure and temperature distributions. Pressure expressed in millibars, temperature in degrees F. (7 h. chart, 17th December, 1917.)

The Northerly Type, see fig. 102 (a).—This type arises when a high-pressure area is centred to the north or north-west of Iceland, and stretches southwards over the Atlantic. On the eastern side of this high-pressure area there sweeps down a cold northerly current from the Arctic, causing “freezing” weather over the British Isles. Such a condition may last for a considerable time, as happened in February, 1895. Fig. 102 (a) is compiled from observations made at 7 h. on 17th December, 1917,

The Easterly Type.—When the continental area of high pressure stretches across Scandinavia and the north Atlantic, then the British Isles are swept by an easterly current on the southern borders of the high-pressure area. This current comes across the continent of Europe, and in so doing has its temperature

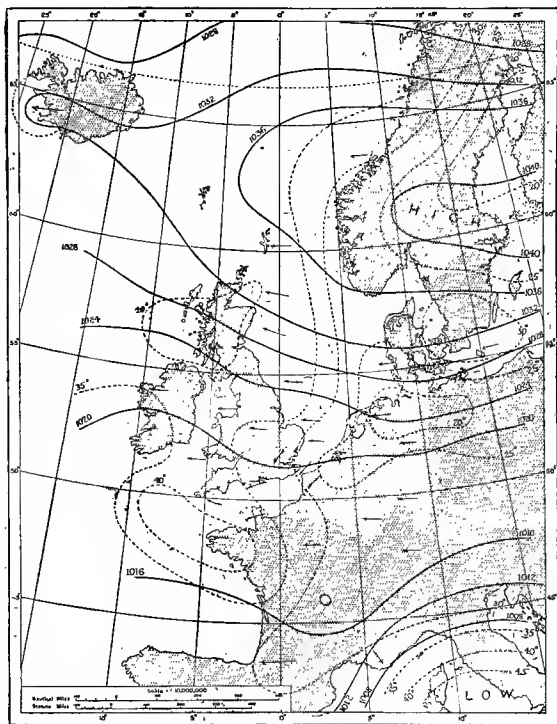

Fig. 102b.—Easterly type, showing pressure and temperature distributions. Pressure expressed in millibars, temperature in degrees F. (7 h. chart, 30th January, 1919.)

lowered. Hence when it reaches the British Isles it causes very keen frost. Such was the condition over England and north-east France during January–February, 1917, and also in January, 1919. See fig. 102 (b), which is the 7 h. chart for 30th January, 1919.

Should the anticyclone recede slightly eastwards across Scandinavia, then the cold current is confined mainly to the eastern side of our islands, the western side coming under the influence of milder southerly currents from the Atlantic.

The North-easterly Type.—Very often, instead of a direct northerly or direct easterly type, the type is north-easterly. In this case the area of high pressure extends from Scandinavia over the north Atlantic, and a belt of low stretches across the Bay of Biscay, France, and the Mediterranean. On the north-west side of

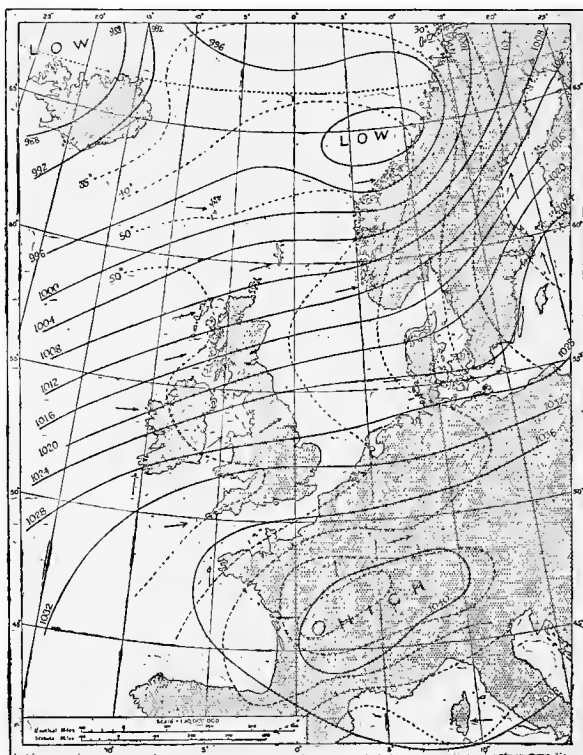

Fig. 103a.—South-westerly type, showing pressure and temperature distributions. Pressure expressed in millibars, temperature in degrees F. (7 h. chart, 16th January, 1920.)

this belt of low pressure is found a strong north-east current forming part of the circulation round the high-pressure centre. Examples of both the easterly and north-easterly types are to be found during the cold spell of January–February, 1917. This period may be divided into two parts: (1) 16th January to 29th January, and (2) 5th February to 10th February. In the first period the high lay mainly over Scandinavia, and an easterly type prevailed over the whole of the British Isles. In the second

period the high-pressure area had contracted, and a belt of high pressure lay across the British Isles. This produced an easterly to north-easterly type over the southern half of the islands, and a westerly type over the northern half.

The South-westerly Type.—When the high-pressure area over

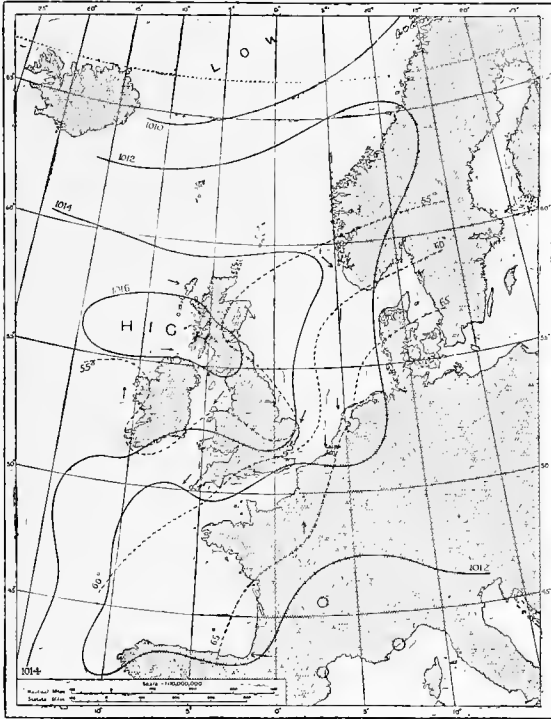

Fig. 103b.—Anticyclonic type, showing pressure and temperature distributions. Pressure expressed in millibars, temperature in degrees F. (7 h. chart, 10th June, 1915.)

the Continent is united by a high-pressure belt across France and Spain with the permanent high on the Atlantic, then the south-west current on the north-western side of this high-pressure region sweeps across our islands, giving a south-westerly type. This type is extremely common in the British Islands.

Depressions pass on a north-easterly track, and this track, which lies to the north-west of Ireland and Scotland, shows a higher frequency than any other depression track (see fig. 74, p. 215).

The weather accompanying this type is, as a rule, milder and more settled than that in the westerly type. An example of this type is shown in fig. 103 (a), wherein the conditions at 7 h. on 16th January, 1920, are represented. It will be noticed that the corresponding isotherms pass farther to the north in this type than in the westerly type.

The Anticyclonic Type. — When an anticyclone becomes centred over the British Isles, the winds become everywhere light and variable. This happens when the Atlantic high spreads north-eastwards and a peak in it is found over our islands. In this anticyclonic type the weather is often cloudy at first, but gradually the sky becomes almost cloudless. At the same time, however, visibility as a rule decreases, the atmosphere becoming very hazy. Often the type persists for weeks on end, as in June, 1915. The pressure and the temperature distributions at 7 h. on the 10th of that month are given in fig. 103 (b).

The Tendency of a Weather Type to continue.—When the changes in the various meteorological elements are closely studied, it is found that the number of changes of weather from one day to another is smaller than the number of continuations of the same kind of weather. After a period of rainy days the chances that the next day will also be wet are greater than the chances of a fair day. Similarly, after a period of fair days the chances that the next day will be fine are greater than the chances that it will rain. In other words, there is a decided tendency for the weather type to persist. The following table, compiled by Mr. E. V. Newnham,¹ shows the probability for a "rain-day" after a number of fine days, and also after a number of rain-days. A rain-day is a day on which at least .2 mm. of rain falls. The values refer to the stations at Aberdeen and Kew.

TABLE XXIX

PROBABILITY FOR A RAIN-DAY

		<i>After successive Fine Days:</i>								
Number of days:—		1	2	3	4	5	6	7	8	9
Aberdeen50	.41	.37	.39	.37	.36	.37	—	—
Kew45	.34	.36	.32	.26	.27	.27	.22	—
		<i>After successive Rain Days:</i>								
Number of days:—		1	2	3	4	5	6	7	8	9
Aberdeen67	.70	.76	.70	.66	.67	.72	.75	.78
Kew56	.61	.61	.64	.64	.67	.73	.69	.70

¹ "The Persistence of Wet and Dry Weather", E. V. Newnham, B.Sc., *Quar. Jour. Roy. Met. Soc.*, Vol. XLII, pp. 153-162.

The results are based on ten years' observations, and show that the chances of a rain-day following a rain-day are about double the chances of a fair day following a rain-day. Especially is this the case after a type has become well established.

Its Value in Forecasting.—This fact is of considerable importance in forecasting, and the governing features are those which we considered as determining the various weather types. In the winter there are in the Northern Hemisphere four permanent highs, one over Asia, one over North America, one over the Atlantic, and one over the Pacific, the last two being smaller than the other two. There are also two low centres, one over the north Atlantic near Iceland, and another in the north Pacific. These areas of high and low pressure have been styled by Teisserenc de Bort the "centres of activity" of the atmosphere, and remain comparatively constant in position in marked contrast to the small moving lows and highs. These centres change their positions slowly and reciprocally, and there is in consequence a tendency for any given type of weather to continue for several days, or even for weeks, as the relative position of these centres determines the tracks of the minor lows and highs.

Forecasting from Local Information.—Though a large organization is required for an efficient meteorological service, yet much may be done in the matter of local forecasting with but limited information. But as in forecasting from synoptic charts, the forecaster must possess both general and particular information, so also must the local forecaster have an accurate knowledge of the general weather conditions prevailing in his locality, and at the same time be able to interpret the indications afforded by the meteorological instruments in his possession. The appearance of the sky and the behaviour of birds and insects are also very useful aids to the local forecaster.

His general knowledge he can acquire by experience and careful study. Thus he may, by a careful study of the winds and the weather, discover the average type of weather associated with winds from particular directions. Again, by comparing the general forecast for his district issued daily by the central office with the actual weather experienced in his locality, he may find out how that forecast must be modified to meet the peculiarities of his own locality. A knowledge of the general circulation of the atmosphere is also requisite, and likewise of the laws governing the circulation of the winds round low- and high-pressure centres.

For detailed information in any particular case he must be in possession of a barometer and, if possible, a barograph, together with thermometers and a wind vane.

From information obtained in these two ways, along with the indications of the sky, a considerable degree of accuracy in forecasting may be reached, though the period of the forecast may be much shorter than that obtainable by the use of synoptic charts.

Hints for Local Forecasting.—In every country there exists a large amount of weather lore. Much of it has little foundation, but there is also some which, having evidently arisen from long continued observation, has considerable value. It pertains generally to the appearance of the sky. The various phenomena which appear in the sky, when properly interpreted, often prove of the greatest assistance to the local forecaster. We shall return to this point again.

A number of ideas have also arisen with regard to the indications of the barometer, some of which are helpful, some the reverse. A low barometer is generally regarded as an indication of bad weather, and a high a sign of good weather. But this need not necessarily be so, and the words "fine, changeable, rainy", often seen on an aneroid barometer, have no real value. The *changes* in the barometric readings are the important features, much more so than the actual readings. Rapid and large oscillations of pressure about a mean value indicate an unsettled condition, whereas slight variations about the same mean value accompany a settled state of affairs.

Temperature and humidity prove also of great assistance. In the spring, keen night frosts often have disastrous effects on vegetation, and it is an important point to know how these frosts may be guarded against. As a rule they can be forecasted with great certainty. If the air has been clear and very dry during the day, as indicated by the difference in temperature between the wet- and dry-bulb thermometers, then considerable cooling by radiation will take place at night, and so precautions should be taken against night frost. If the difference in temperature between the two thermometers is small during the day, then the air is damp and either clouds or fog will form at night, and so prevent radiation and consequent cooling.

In winter, when walls and stones become moist after a spell of clear, cold weather, this phenomenon indicates the approach of a comparatively warm, moist current, and rain is almost sure to

follow. Similarly, if after a series of clear nights on which there has been but little dew, a night comes on which there is abundant dew, it is evident that the humidity of the air has suddenly increased, and therefore a change of weather is to be expected. If, on the other hand, there occurs a series of nights on which there is abundant dew, fair weather is likely to last; for dew forms most readily when the air is still and when there is a large inversion of temperature, i.e. when the upper layers of the air are comparatively warm and dry, a condition likely to maintain fair weather.

Colours at sunrise and sunset depend to a large extent on the presence of small drops of water in the atmosphere, and from these colours one may deduce the amount of moisture in the atmosphere, and hence the type of weather to be expected.

The local forecaster will also find the observation of cirrus very useful. Small patches of cirrus having scarcely any perceptible motion accompany fine weather in all parts of the world. But if the cirrus is moving very rapidly, it is a sure sign of a coming storm, especially if arranged in bands, and the intensity of the storm may be gauged from the velocity of the cirrus. The presence of false cirrus is also a point worthy of note. This false cirrus often appears from thirty-six to forty-eight hours in advance of the coming storm. It has become detached apparently from the storm-clouds where it was originally formed, and has been carried forward by a current moving with greater velocity than that in which the larger mass of the cloud finds itself. As a concrete example there appeared at Aberdeen, on the 31st October, 1919, in the evening, after a fine day, large quantities of false cirrus. At sunset the sky in the west assumed a red and angry look. Next morning dawned fair, and the day was mainly fine, but on the following day came stormy weather, with frequent snow and hail showers, accompanied by high winds.

The appearance of a halo is often the forerunner of a depression with its accompanying bad weather. But the halo will be followed by bad weather only if the barometer is *falling* at the time of its appearance. If the barometer is *rising* at the time of its appearance, the phenomenon is likely to be followed by fairer weather, as the halo has been due to cirro-stratus in the rear of the depression and not in front.

Cirro-stratus with its halos is very often followed by alto-stratus when the cirro-stratus is in front of a depression. When this alto-

stratus appears, the sun or moon shining through the cloud has what is called a "watery" appearance. This is almost a certain sign of rain, the rain following within a period of twelve hours. Such an appearance is occasionally called a "weak sky". On the other hand, behind a depression the sky assumes a "hard" appearance. From such a sky occasional squally showers may be expected, but not continuous rain.

The study of the behaviour of certain birds and insects during certain weather conditions also proves helpful, while the approach of bad weather is often indicated by its effect on such ailments as rheumatism.

From all these various phenomena the local forecaster will acquire sufficient information whereby he will attain considerable success, provided he apply his knowledge in a scientific way. The chief problem for him is to eliminate the signs which arise from atmospheric influences from those which have no such origin. Certain cloud phenomena have different significance in different districts or in different countries, and therefore the same conclusions must not be drawn in all regions from the appearance of certain types of cloud. Whenever possible the general forecast issued by the Central Meteorological Office should be obtained, and this, combined with local information, will ensure for the local forecaster considerable success in forecasting the weather conditions during the next twenty-four hours.

Long-distance Forecasting.—By long-distance forecasting is meant the forecasting of weather so many days, weeks, or months in advance. Various methods have been resorted to in order to forecast the weather for a long period ahead, but in the present state of our knowledge of weather conditions it is practically impossible, except under exceptional circumstances, to forecast with accuracy more than twenty-four hours in advance.

When an unsettled westerly type of weather is prevailing, one may say that the unsettled conditions are likely to last for several days, but within this period several fair intervals are sure to occur. The exact time at which these intervals will occur cannot, in general, be foretold at a longer interval than twenty-four hours ahead and often only twelve hours in advance, the time for which the forecast is valid depending very much on the velocity of translation of the depressions. A depression takes on an average three days to cross the British Isles, from its first appearance in the west

until it disappears in the east. From a knowledge of this fact a general forecast covering a period of three days might be issued, but as each depression has its own rate of advance and its own peculiarities as regards weather, such a three-days' forecast can only be given in general terms.

In anticyclonic weather a forecast covering a period of a week or even longer can at times be made with considerable accuracy. Within a large anticyclone the weather is often uniform over a large area, and the kinetic energy in the system is much less than in a cyclone. As the anticyclone moves but slowly, fair quiet conditions may prevail for a comparatively long period. But apart from examples of this kind long-distance forecasting is at present impossible by means of ordinary synoptic charts.

Meteorological Periods.—Attempts have been made at forecasting months or even years in advance. Such forecasts are given only in general terms. For example, a certain summer may be predicted as likely to be exceptionally dry, or a certain winter as extremely severe. Forecasting of this kind rests on the belief that meteorological phenomena show a periodicity just as sun-spots do.

Solar Periods.—The sun revolves on its axis in the same direction as the earth does in its orbit, and the time occupied in a complete revolution of the sun is 24.86 days. But in this time the earth has moved along a certain distance in its orbit, and so 26.68 days are required for a particular point on the sun to come again into the same relative position with regard to the earth. If the rotation of the sun affects the meteorological elements at the earth's surface, there ought then to be a 26.68-day period. No such periodic effect sufficiently great to be of service in forecasting has been detected, however.

Sun-spot Periods.—Another period in connection with the sun is the sun-spot period. The length of this period is, on the average, 11 years 2 months, and many researches have been undertaken with a view to determining whether there exists any connection between these sun-spots and the variation of the meteorological elements. These investigations point to a periodic variation of temperature in tropical latitudes, the period corresponding to the sun-spot period. The amplitude, however, is very small, amounting to not more than 0.7° A. at most. The number of tropical cyclones also shows a variation of the same period, but it is doubtful if there is any close connection between the two phenomena.

Lunar Periods.—It is a very common belief that the moon influences the weather. This belief has been handed down from remote ages and has caused much controversy. Such phrases as “the weather will not change until the moon changes”, or, “there will be no improvement in the weather until there is a new moon”, are very common, and are firmly believed in by many. The interval that must elapse for the sun, moon, and earth to be in the same relative positions is about 27·2 days, a period nearly the same as that of the sun’s revolution. If there were a 27-day period, it could be attributed, therefore, either to the sun or to the moon, or to both.

As the moon is the main factor in the production of the tides, researches have been made to find whether it also produces tides in the atmosphere. A slight effect has been found in equatorial regions, but outside these regions no effect has been found. Though the moon causes a slight tidal effect on pressure only near the Equator, yet it is possible that the variation of pressure with latitude may change slightly with the variation in the altitude of the moon. Such an influence would be manifested by a slight displacement of the high- and low-pressure zones, and as the position of these high- and low-pressure areas determines the weather types, it is possible that some such influence does exist. This influence would arise from the variation in altitude of the moon, and not from its period of revolution or from its phases as commonly believed.

Brückner Periods.—Another period which has claimed attention is what is known as the Brückner period. Researches made on the change in level of the water in the Caspian Sea showed in the mean a period of 34 to 36 years. This period corresponded to analogous periods in the temperature and rainfall variations in Russia. Observations made in other parts of the world on the variation in the level of water in lakes and rivers showed somewhat similar results. During the last two centuries the times when the levels of lakes and rivers were lowest and highest respectively are:

Lowest: 1720, 1760, 1795–1800, 1831–5, 1861–5.

Highest: 1740, 1775–80, 1820, 1850, 1876–80.

During the same time the warm and cold periods were:

Warm: 1746–55, 1791–1805, 1821–35, 1851–70.

Cold: 1731–45, 1756–90, 1806–20, 1836–50, 1871–1885.

The dry and wet periods were:

Dry: 1756–70, 1781–1805, 1826–40, 1856–70.

Wet: 1736–55, 1771–80, 1806–25, 1846–55, 1871–85.

Thus there appears a general connection on the one side between the warm and the dry periods, and on the other between the wet and the cold periods. The variations are more marked over continental areas than on the oceans and in districts adjoining the seas. The intervals, however, are very variable, so rendering it impossible to base a method of forecasting upon them.

None of the periods considered, therefore, are such as would permit of a method of long-distance forecasting being based on them in the hope of obtaining any high degree of accuracy. The only method whereby fair accuracy can be obtained at present is by means of synoptic charts, and with these the forecast is limited to 24 or 48 hours, though under exceptional circumstances it may be possible to forecast for a somewhat longer period.

B.—CLIMATE

Weather and Climate.—Reference has already been made to the difference between weather and climate. Weather refers to a particular place and to a particular day or hour of the day, and is defined when the numerical values of the different meteorological elements are stated. Climate, on the other hand, applies to a much larger area and to a much longer time, and so may be defined as generalized weather. So in order to ascertain the climate of any country or locality, recourse must be had to tables of statistics giving the normal values of all the various meteorological elements, together with data concerning the composition of the atmosphere, solar radiation, the temperature of the ground, the amount of evaporation, the frequency of thunderstorms, and of fogs, visibility, &c.

Summaries Required in Studying the Climate of a Country.—In his *Handbuch der Klimatologie* Hann mentions thirty-six summaries of data which should always be included in the study of the climate of a country. Six more summaries have been added to this list by Abbe in his *Aims and Methods of Meteorological Work*. In Hann's summaries are included the mean monthly and annual values of the various meteorological elements, and also the extreme values of these elements recorded within a long period of time; the number of days of frost and the number of spells of frost; the average time of the commencement of frost in the late autumn and of the last appearance of frost in the late spring; the number of thunderstorms and the frequency of hail;

the amount of bright sunshine and the frequency of fogs; the weather associated with the wind from the eight principal points of the compass; the average amounts of evaporation and of precipitation together with extreme values of the same; the composition of the atmosphere and its variations; impurities in the atmosphere, especially the number of germs of organic life; the electrical condition of the atmosphere.

The other summaries added by Abbe are as follows:

(1) The sensation experienced by the observer, such as mild, balmy, invigorating, depressing, and other terms used to express the effect of the weather on mankind.

(2) The number of storm centres that pass over a given locality, monthly and annually.

(3) Frequency of severe local storms.

(4) The duration of twilight.

(5) The blueness or haziness of the sky.

(6) The number and extent of the sudden changes from warm to cold, or from moist to dry weather, and vice versa.

If summaries of data such as these just mentioned are available for any district, then by a close study of them one can form a comparatively accurate conception of the climate of the district.

The Factors which Determine Climate.—The word climate is derived from a Greek work *κλίμα*, a slope or inclination, and the term climate was applied to one of a series of regions into which the earth was divided by lines running parallel to the Equator. Hence climate came to be applied to the average type of weather prevailing in that zone, because the average type of weather in a region depends largely upon its distance from the Equator. The first factor which determines climate, therefore, is latitude or distance from the Equator. But the amount of solar radiation received in a particular area is not the only factor which determines the climate of a country, and so any simple distribution of the surface of the globe into zones according to latitude must be modified by reason of the effects produced by certain other factors. Some of these effects are to be found (1) in the elevation of a region above sea-level, (2) in mountain ranges, (3) in the topography of the country, including the nature of the soil, and (4) in the presence or absence of vegetation; also (5) in the relative distribution of land and water, (6) in the prevailing wind systems, and (7) in the ocean currents.

The climate which would result from solar radiation alone is sometimes called the "solar climate", and this modified by the above factors is termed the "physical climate".

Climatic Subdivisions of the World: LATITUDE.—The first subdivision of the surface of the globe into climatic zones was carried out by the Greek philosophers, and was made on the basis of latitude. The division into the five zones used at the present day is generally ascribed to Parmenides, who flourished about 450 B. C. These zones are the torrid zone, two temperate zones, and two frigid zones. The torrid zone is included between the tropics of Cancer and Capricorn; the frigid zones are bounded on their equatorial sides by the Arctic and Antarctic Circles respectively, and stretch to the poles, the two temperate zones being included between the frigid zones and the torrid zone. The torrid zone covers 40 per cent of the earth's surface, the two temperate zones 52 per cent, and the two frigid 8 per cent. A subdivision of this nature, however, takes account only of the amount of solar radiation received per unit area of surface, and takes no account of the other factors which go to form climate.

The names used for the different zones are rather unfortunate, as they suggest a division on a temperature basis, whereas the division is on the basis of latitude only. Until comparatively recently, however, this subdivision according to latitude was the only method employed.

TEMPERATURE.—The most important meteorological element affecting both plant and animal life, and also the life and occupations of man, is temperature. A division of the globe on a temperature basis is then a much better method than the previous method. The divisions under this scheme follow the isotherms instead of the parallels of latitude. In studying the temperature distribution over the surface of the earth we saw that there was, on the whole, a fall of temperature from the Equator to the poles, but that this fall was by no means regular, being modified by the relative distribution of land and water, by elevation above sea-level, by the prevailing wind systems, by ocean currents, and by the presence or absence of vegetation. All these factors, therefore, alter the temperature distribution which would arise from the effect of solar radiation alone, whereby the isotherms become irregular lines encircling the globe. These lines, however, still remain, after a rough fashion, parallel to the Equator. Supan has suggested that the torrid zone be bounded

on either side by the normal annual isotherm of 293° A. (68° F.); that the temperate zones should be bounded on the polar sides by the 283° A. (50° F.) normal isotherm for the warmest period of the year, and that the regions beyond these limits be the frigid zones. In this subdivision of Supan the same number and the same names of the zones are retained, as in the subdivision according to latitude. Other subdivisions according to temperature have been suggested, in which the number of zones has been increased.

According to Supan's subdivision, the whole of Europe, the greater part of Asia, and also of North America would fall within the temperate zone, so that a division according to isotherms alone does not afford a solution.

PREVAILING WINDS.—But though temperature plays a very important part in the distribution of plant and animal life over the surface of the globe, this distribution is also affected to a very large extent by precipitation and humidity. The chief factor in determining the distribution of precipitation and also of humidity is the prevailing wind system, so that the world may be divided into a series of climatic zones with this system as a basis. In this system nine zones are generally recognized, a central zone in the neighbourhood of the Equator, and four zones on either side of it. The central region includes the doldrums and the regions of the trade winds invaded by the doldrums at different seasons of the year. On either side are the two trade-wind zones proper. Beyond these lie the subtropical, high-pressure belts with their calms, while on the polar sides of these calms are the zones of the prevailing westerlies extending to the poles. These two zones have each been divided into two by the polar circles, thus giving nine zones in all. Such a division, however, suffers from the same fault as did the other two.

TOPOGRAPHY.—In all the subdivisions considered, each zone includes large tracts of both sea and land. As climate is determined not by temperature alone, nor by humidity alone, nor by precipitation alone, but by a combination of all three together with certain other factors already enumerated, so the climate in every portion of the same zone is by no means the same. A further division thus becomes necessary, and this has been carried out on a basis of surface topography. In this further division six subdivisions are usually recognized. The two main subdivisions are continental and marine, but as these present great differences within themselves, each is divided into three, the continental into plain, plateau, and

mountain, the marine into ocean, west coast, and east coast, giving hereby six subdivisions in all.

If, then, the world is first divided into zones according to temperature or prevailing wind systems, and these zones be further subdivided according to the topography of the zone, then a rational division of the globe into areas, for which a general description of the climate in each case can be given, will be arrived at.

Other Methods of Subdivision.—Besides the methods of subdivision given above, other classifications have been given. Köppen gives a subdivision of the world on a botanical basis; Ravenstein, in his classification, uses temperature and relative humidity as a basis; while a classification has been given by Herbertson, based upon a combination of temperature, rainfall, topography, and vegetation.

THE CLIMATE OF THE BRITISH ISLES

The climate of the British Isles is essentially a marine climate. The mass of land is too large for the climate to be called an ocean climate; neither is it altogether a west coast climate, but is rather a combination of the two. It is largely determined by the prevailing south-westerly winds, apart from the geographical position of the islands, which brings them within the limits of the temperate zone. Though the extent of the country is not great, yet there exist marked differences from one locality to another, especially as regards rainfall and bright sunshine. For climatological purposes, therefore, the country has been divided into twelve districts,¹ and from observations taken within each district, summaries have been prepared, and the average climate for each district ascertained.

Factors which Determine the Climate: SUMMER.—On the northern side of the large permanent anticyclone over the Atlantic prevails the strong south-west to west current, and in this current are found the cyclones which cross the British Isles. In the summer this high-pressure area advances northwards, and the track of the low-pressure centres along its northern side passes farther to the north. In this way the prevailing south-westerly winds are modified by currents sweeping down from the north or north-west behind the depressions. These currents approach the

¹The climatological districts of the British Isles are:

- | | | |
|------------------|----------------------|----------------------|
| 0. Scotland, N. | 4. Midland Counties. | 8. England, S.W. |
| 1. Scotland, E. | 5. England, S.E. | 9. Ireland, N. |
| 2. England, N.E. | 6. Scotland, W. | 10. Ireland, S. |
| 3. England, E. | 7. England, N.W. | 11. English Channel. |

British Isles from the north-west or west, and as they are relatively cold, the temperature on the north-west coasts in particular remains low. At the same time the currents, coming as they do from over the sea, are moisture-laden, and on reaching the land are forced upwards by the mountain ranges, thus becoming cooled adiabatically. Much cloud and precipitation is therefore experienced in the western and north-western districts. As the currents are deprived of much of their moisture soon after reaching the land, and as the mountain ranges are confined mainly to the western and north-western portions of the islands, the currents on passing over the mountains and reaching the eastern side become warmer and drier. Districts on the eastern side are, in consequence, warmer and drier than those on the western side of the mountains. As the air is drier there will be also less cloud amount, and therefore longer periods of bright sunshine. This explains why the districts bordering the Moray Firth, to the east of the Pennine range, over central England and eastern Ireland, have less rainfall and more bright sunshine than the other districts.

WINTER.—In the winter-time the track of the depressions lies more across the British Isles, as the Atlantic anticyclone has receded southwards. The western coasts come under the influence of winds mainly south-westerly. Through contact with the land these currents are cooled and precipitation is therefore abundant. But on account of their origin the currents are comparatively warm, so that the western coasts, though wet, very often enjoy mild weather.

Effect Modified by the Continental High-pressure Area.—On the other hand, the eastern coasts often come under the influence of the great anticyclone over the continents of Europe and Asia, and as the currents on the western borders of this anticyclone come across large land areas, they are dry and cold. In this way the eastern coasts often experience hard frosts, while on the western coasts the temperature is well above freezing-point. The warm south-westerly current in such a distribution of pressure does not reach the eastern side of the islands, and therefore there is no föhn effect as takes place when the current approaches from the north-west or west.

Effect of the Gulf Stream.—Another factor influencing to a slight extent the climate of the British Isles is the Gulf Stream. The world isotherms show how the temperature along the north-

west coast of Europe is affected by this ocean current, and the temperature of the western and the northern shores of the British Isles shows in particular its influence. The western islands, washed on all sides by the waters of the Stream, experience only a slight annual temperature range, and the western coasts of the mainland of Scotland and Ireland have a similar small range. A branch of the current enters the Irish Sea, modifying the temperature variation on the west coasts of England and Wales and also on the eastern Irish coasts. But the district where the influence of the Gulf Stream is most marked is perhaps that of Cornwall and Devon. Along the Channel in winter, temperature falls from west to east partly on account of the shallowness of the water, which thereby cools much more rapidly, and partly on account of the cold winds blowing off the Continent. In the summer-time the reverse takes place, and so on account of the influence of the Gulf Stream temperature remains much more uniform over Cornwall and Devon than over the rest of southern England.

The eastern coast is dominated by the North Sea, and though part of the Gulf Stream flows round the north of Scotland and enters the North Sea, large quantities of cold water also enter it from the Baltic. Thus the temperature of the sea-water on the eastern coasts is lower than that on the western coasts. The climate of the east coast therefore does not benefit from the Gulf Stream to the same extent as the climate of the west coast does.

The climate of the British Isles is therefore largely dominated by the prevailing south-westerly winds, aided by the situation of the mountain ranges, and the waters of the Gulf Stream.

Temperature Distribution.—Throughout the year the temperature varies comparatively little in the Hebrides, and likewise all along the western shores of Scotland and Ireland, the annual range in these localities being only 8° A. On the other hand, the east coast shows a greater range, especially in the south-east of England, where it exceeds 13° A. In general terms, then, the range in temperature increases from north-west to south-east.

Rainfall Distribution.—An examination of the rainfall distribution shows that the western and northern portions of the islands have a greater annual rainfall than the eastern and south-eastern districts. This is just as one would expect from the factors we have considered and from the position of the mountains. For the air currents passing over the eastern portions of the

country are either currents from the Atlantic which have been largely deprived of their moisture on crossing the mountains, or they are dry currents from the Continent, cold in winter, warm in summer.

The region of greatest rainfall is in the western highlands of Scotland, where the annual amount surpasses 2000 mm., while the driest region is in the Fens round the Wash and at the mouth of the Thames, the annual rainfall in these districts being under 650 mm.

Cloud and Bright Sunshine Distribution.—The average cloud amount over the British Isles is about six tenths of the possible, but the distribution is not uniform. It shows a maximum in the north-west and a minimum in the south-east. The same happens in the case of bright sunshine, the order of course being reversed, the amount of bright sunshine increasing from north-west to south-east. As the total amount of bright sunshine depends to a great extent on the portion contributed during the summer season, and as in that period the air currents approach mainly from the west or north-west, the part played by the mountain ranges in the cloud and sunshine distribution is at once evident.

Extreme Values.—Extreme values in temperature are practically unknown. In one small district in the central highlands of Scotland the mean value of the temperature falls below the freezing-point during two months of the winter; elsewhere the monthly mean values are above 27° all the year round. Hot periods in the summer with a monthly mean value 29° A. or more are never encountered. Long periods of intense heat or of intense frost are therefore never met with. Excessive rainfall and excessive drought are likewise almost unknown. Occasionally a very dry summer, as in 1828, or a very severe winter occurs. But these are the exception, not the rule, and the climate of the British Isles is in every sense a temperate climate.

This is but a brief outline of the climate of the British Isles. For a detailed study recourse must be had to the statistics compiled from observations taken in the twelve separate districts already referred to, and that is a study which lies outside the scope of the present book.

INDEX

A

Abbe, 377.
 Abbot, 50.
 Abercromby, Rt. Hon. Ralph, 163.
 Abercromby's weather type, 363.
 Accademia del Cimento, 4.
 Actinometer, Roscoe's, 53.
 — Violle's, 48.
 Adiabatic diagram, 160.
 — lapse rate, 158.
 Airmeter, 123.
 Airy, 336.
 Aitken, 34.
 Aitken's Dust Counter, 33.
 Altimeter, 110.
 Anemometer, 119.
 — Dines', 120.
 — Robinson-Beckley, 122.
 Angot, A., 42, 45, 47, 113, 125, 140, 239.
 Ångström's Pyrheliometer, 48.
 Anticyclones, 220.
 — pressure distribution in, 221.
 — velocity of translation of, 223.
 — weather and cloud distribution in, 222.
 — wind distribution in, 221.
 α -rays, 319.
 Archibald, E. D., 257.
 Aristotle, 2, 324.
 Assmann, 10, 258.
 — Psychrometer, 58, 151, 259.
 Atlas of Clouds, International, 163.
 Atmosphere, the, Chapter II, 27.
 — coefficient of transparency of, 45.
 — Isothermal Layer of, 11, 78, 268.
 — homogeneous, 37.
 — minor constituents of, 32.
 — permanent constituents of, 29.
 Atmospheric circulation according to Ferrel, 134; Hildebrandsson and de Bort, 135.
 — equilibrium, 77.
 Aurora, 318.
 — cause of, 319.
 — spectrum of, 320.

B

Baguios, 233.
 Ballons-sondes, 11, 258.

Balloon ascents, 10.
 Balloons, pilot, 259.
 Bar, the, 101.
 Barograph, 100.
 Barometer, aneroid, 100.
 — corrections on reading, 99.
 — Fortin, 97.
 — Kew pattern, 98.
 — simple mercurial, 96.
 — standard, 97.
 Barometric depression, 199.
 — gradient, 130.
 — tendency, 354.
 Batavia, 11.
 Beanfort, Admiral, 118.
 — scale, 119.
 — weather notation, 356.
 Bebbet, W. van, 214.
 Beccaria, 293.
 Belt of maximum cloudiness, 177.
 Bentley, W. A., 184, 194.
 Bigelow, 200.
 Birkeland, 53, 319.
 Birt, 257.
 Blue of the sky, 339.
 Bolometer, the, 50.
 Bora, the, 227.
 Bort, Teisserene de, 10, 11, 78, 163, 257, 267.
 Bouguer, 45.
 Boyle, 4, 28.
 Boyle's Law, 28.
 Brandes, H. W., 7, 200.
 Bravais, 331.
 Breezes, land and sea, 144.
 Brückner Periods, 376.
 Buchan, 10.

C

Castelli Benedetto, 4.
 Cathode rays, 53, 319.
 Cave, Captain C. J. P., 11, 259, 279, 285, 287.
 Cavendish, 28.
 Celsius, 56.
 Centres of activity, 371.
 Charles' Law, 28.
 Chinook wind, 226
 Christie, Miller, 350.

Circulation, anticyclonic, 134.
 — cyclonic, 133.
 — general, of the atmosphere, 134.
 "Cirrus", the, 258.
 Clarke, G. A., 249, 319.
 Clayton, 163.
 Climate, 16, 377, and Chapter XII, 377.
 — of the British Isles, 381-384.
 Climates, ocean, regular, extreme, 76.
 Climatic subdivisions of the world, 379.
 Cloud amount, 173.
 — — annual and diurnal variation of, 176.
 — — distribution over the globe, 177.
 Clouds, 162.
 — classification of, 162.
 — formation of, 170-173.
 — heights of, 167.
 — international classification of, 163-167.
 — iridescent, 333.
 — measurement of velocity and direction of, 167.
 Col, 224.
 Collectors, flame, water-dropper, ionium, 295.
 Colour, blue, of the sky, 339.
 Colours, sunrise and sunset, 340.
 Condensation, 157.
 — methods of causing, 158-161.
 Conductivity, electrical, 305.
 Corless. See LEMPFERT.
 Corona, 333.
 — cause of, 334.
 Correlation, 23.
 — coefficient of, 24.
 — partial, 24.
 Coulomb's Law, 302.
 Counter-sun, 330.
 Coxwell, 10, 257.
 Crochet d'orage, 252.
 "Cross", 330.
 Crova, 50.
 Cyclone, extratropical, air supply, 210.
 — — characteristics of, 201.
 — — cloud in, 210.
 — — energy in, 232.
 — — extent of, 201.
 — — general weather characteristics, 208.
 — — intensity of, 208.
 — — movements of, 213.
 — — origin of, 229-232.
 — — passage of, 208.
 — — path of centre, 215.
 — — pressure distribution in, 201.
 — — rain in, 213.
 — — signs of approach of, 212, 359.
 — — temperature distribution in, 210.
 — — trajectories of air in, 210.
 — — trough of, 202.
 — — weather distribution referred to centre, 208.
 — — wind in, 203-208.
 — tropical, characteristics of, 233.
 — — distribution of meteorological elements in, 235,

Cyclone, tropical, origin of, 239-241.
 — — passage of, 234.
 Cyclones, tropical, central eye of, 234, 236.
 — — regions of, 233.
 — — seasons of, 238.
 — — trajectories of, 236.
 — — velocity of translation of, 238.
 Cyclostrophic wind, 204.

D

Dampier, 232.
 Davis's *Elementary Meteorology*, 44.
 De Dominis, 336.
 Depression. See CYCLONE.
 Deviation, standard, 21.
 Dew, 181.
 — point, 147.
 Diffraction, phenomena due to, 333, 334.
 Dines, J. S., 205, 282.
 — W. H., 10, 25, 26, 231, 258, 267, 271, 276.
 Divergent winds, 358.
 Doldrums, 139.
 Dolezalek, electrometer, 296.
 Dove, 6, 80, 200, 233.
 Dust particles, counting of, 33.
 — — number of, 34.
 Dynamical cooling, 158.

E

Easterly current, cause of, 137.
 Ebert, 307, 309, 317, 318.
 Ebert's Ion Counter, 307.
 Eddy motion, conductivity, 178.
 Ekholm, N., 10, 216.
 Electrical density, force, potential, 294.
 Electrometers, 296.
 Elements, meteorological, 16.
 Elster and Geitel, 293, 303, 304, 311, 312, 317.
 Energy, radiant, 38.
 Equation, regression, 24.
 Equipotential surfaces, 294.
 Espy, 7, 200, 233.
 Ether, the, 38, 293.
 Eurydice squall, 246.
 Evaporation, 146.
 Evaporimeters, 146.
 Exner, 325. See also PERNTER.
 Eye, central, of tropical cyclone, 234, 236.

F

Fahrenheit, 55.
 — thermometer, 55.
 Fata Morgana, 323.
 Ferdinand II, 4.
 Fergusson, 174.
 Ferrel, W., 8, 9, 200, 233.
 — circulation of atmosphere according to, 134.
 Field, earth's electric, 297,

Fisher, Rev. G., 256.
 FitzRoy, Admiral, 8, 361.
 Fog, 177.
 — land, 179.
 — prediction for aerodromes, 181.
 — radiation, 180-181.
 — sea, 178.
 Föhn wind, 226.
 Forecasting districts, 360.
 — from local data, 371.
 — general methods of procedure, 353-358.
 — Guilbert's rules for, 358.
 — hints for local, 371.
 — information necessary for, 352.
 — long distance, 374.
 — of gales, 361.
 — organization necessary for, 353.
 Franklin, 293.
 Frost, 182.
 — glazed, 182.
 — hoar, 182.
 Frosts in spring, 371.

G

Gales and storm warnings, 361-363.
 Galileo, 3.
 Galle, 331.
 Galton, Sir Francis, 8, 24.
 Gay Lussac's Law, 28.
 Geitel. See ELSTER.
 Geostrophic wind, 203.
 — — direction, 205.
 — — velocity, 206.
 Gerdien, 308, 311, 317.
 Gewitternase, 252.
 Glaisher, 10, 257.
 Glaisher's factors, 152.
 — relation, 149.
 Glories, 333.
 Gold, Lieutenant-Colonel E., 10, 222, 263, 267, 269.
 Gradient, barometric, 130.
 — vertical temperature, 267.
 — wind, 204.
 Grain, 252.
 Greek influences, 2.
 Greeks, 1.
 Guericke, Otto von, 27.
 Guilbert, M. Gabriel, 358.
 Guilbert's rules, 358.
 Guldberg, 10.
 Gulf Stream, 91.
 — — influence of, on climate of the British Isles, 382-383.
 Gunfire, audibility of distant, 350.

H

H_c , height of the troposphere, 270.
 Hadley, 5.
 Hail, 196.
 — in thunderstorms, 254.
 Halley, 5.

Halo, 327.
 — cause of, 330.
 Hann, 29, 50, 200, 377.
 Harwood, 263.
 Haze, anticyclonic, 370.
 Health, effect of weather on, 15.
 Height clouds, 167.
 — of atmosphere, 35.
 Hellmann, 2, 4.
 Helmholtz, 170.
 Hergesell, 257.
 Hertz's diagram, 158.
 — — modification of, by Neuhoff, 159.
 High-pressure areas, 113.
 Hildebrandsson, 10, 163.
 Hoar-frost, 182.
 Homogeneous atmosphere, 37.
 Horse latitudes, 139.
 Howard, Luke, 162.
 Humidity, absolute, 147.
 — — annual variation of, 153.
 — — diurnal variation of, 152.
 — — variation with latitude and altitude, 154.
 — relative, 147.
 — — annual variation of, 155.
 — — diurnal variation of, 154.
 — — variation with latitude and altitude, 156, 157.
 Humphreys, 31.
 Hurricanes, 233.
 Huygens, 330.
 Hygrograph, 150.
 Hygrometers, 149-151.
 Hygrometry, 149.

I

Ice crystals, 331.
 Insolation, 39.
 — law of absorption of, 45.
 — variation in amount received according to latitude and time, 41.
 International Aeronautical Conference, 257.
 — Cloud Atlas, 163.
 — Meteorological Conference, 163, 257.
 Invariable layer, the, 89.
 Inversions of temperature, 77, 177, 268.
 Ionized air, 308.
 Ions, 304, 307.
 Iridescent clouds, 333.
 Irisation, 334.
 Isallobars, 216.
 Isanomalies of temperature, 86.
 Isanomalous charts, construction of, 85.
 Isobaric charts, 111.
 — — annual, 111.
 — — summer and winter, 114.
 Isobars, 111.
 — various forms of, 224.
 Isohyets, 189.
 Isothermal charts, annual, 80.
 — — charts, construction of, 79.

Isothermal charts, summer and winter, 82.
— layer, the, 11, 78, 268.

J

Jelinek, 10.

K

Keller and Thom, 7.
Kelvin, 293, 301.
— quadrant electrometer, the, 296.
— water-dropper, the, 295.
Kepler, 324, 325.
Kites, investigation by means of, 257.
Köppen, 215.
Krakatoa, eruption of, 143.

L

Labrador current, the, 91.
Langevin, 306.
Langley, 50.
Laplace, 345.
Laplace's Law, 108.
Lapse rate, adiabatic, 77, 158.
Lavoisier, 28.
Layer, the invariable, 89.
— isothermal, 11, 78, 268.
Le Monnier, 293.
Lempfert, R. G. K., 213.
— and Corless, 246, 247.
Lenard, 183, 306.
— effect, 300.
Leonardo da Vinci, 340.
Le Verrier, 8, 9, 259.
Ley, Rev. Clement, 163.
Life History of Air Currents, 213.
Lightning, 314.
— colour of, 315.
— conductors, 315.
Ligne de Grain, 252.
Line squall, 244.
— — air motion in, 247.
— — cloud, 248.
Linss, 303.
Local influences on weather, 371.
Looming, 323.
Loomis, 8, 318.
Low-pressure areas, 113.

M

M'Adie, 53.
Mackerel sky, 164.
Mariotte, 330.
Maury, 6.
Mean values, 18.
— — problems solved by, 19.
Meldrum, 7, 233.
Meteorographs, Ballons-sondes, 261.
— calibration of, 263.
— Dines Ballons-sondes, 261.
— Dines kite, 261.
— kite, 260.
Meteorological Periods, 375.

Mill, Dr. H. R., 190.
Miller, H., 339.
Millibar, definition of, 101.
Millikan, 307.
Mirage, 322.
Mist, 181.
Mistral, the, 228.
Mock-suns. See PARHELIA. Mock-moons.
See PARASELENÆ.
Mohn, H., 10.
Monsoons, 143.
Montigny, 325.
Montigny-Exner theory, 326.
Moon pillars. See SUN PILLARS.
Mountain and valley winds, 145.
Mountains, influence of, on rainfall, 185.
— on climate of British Isles, 382-384.
Munro-Rooker Direction Recorder, 121.

N

Nephoscope, Comb, 170.
— Fineman, 168.
Neuhoff, 159.
Newfoundland, 179.
Newnham, E. V., 370.
Newton, 336, 345.
Normal wind (Guilbert), 359.
Nuclei for condensation, 34, 162, 317.

P

Paraselenæ, 329.
Parhelia, 329.
— cause of, 332.
Parry, Captain Sir E., 256.
Pascal, 27, 96.
Paths of air currents entering a cyclone, 210.
Peltier, 294, 311, 316.
Periods, Brückner, 376.
— lunar, 376.
— solar, 375.
Pernter, 324, 327.
Pickering, 174.
Piddington, 7, 200, 233.
Pilot balloons, 259.
— — methods of observation of, 279-283.
— — results of observation of, 285.
Pressure, definition of, 95.
— distribution over the globe, 111.
— hypothesis *re* diurnal variation of, 106.
— reduction to sea-level, 109.
— relation to temperature distribution, 117.
— types of. See WEATHER TYPES.
— units, 101.
— variations, annual, 107.
— — diurnal, 102.
— variation with altitude, 108, 271.
Pressures and temperatures in cyclones and anticyclones, relations between, 273-278.
Priestley, 28.
Psychrometer, Assmann, 59, 151.

Psychrometer, wet and dry bulb, 150.
 Ptolemy, 324.
 Purple light, cause of, 342.
 — the first, 341.
 — the second, 343.
 Pyrheliometer, Abbot's Silver-disc, 48.
 — Ångström's, 48.
 — Callendar, 53.
 — Pouillet's, 47.

Q

Quadrant Electrometer, the, 296.

R

Radiation, Chapter III, 38.
 Rain, types of, 184-185.
 Rainbow, 335.
 — cause of, 336-338.
 — colours of, 335.
 — undulatory theory of, 338.
 Rainbows, supernumerary, 335.
 Rain-days, probability of, 370.
 — in anticyclones, 223.
 — in cyclones, 213.
 Raindrops, size and distribution in rain-storm, 183.
 — size and distribution in thunderstorm, 253.
 Rainfall, annual and diurnal variations of, 187.
 — early records of, 4.
 — measurement of, 185.
 — distribution over the British Isles, 190.
 — distribution over the globe, 190-192.
 — in thunderstorms, 253.
 — records, 186.
 Rain-gauge, 185.
 — Korean, 4.
 Ramsay, Sir William, 28, 29.
 Rayleigh, Lord, 29, 339, 340.
 Redfield, 6, 233.
 Reflection, phenomena due to, 333.
 Refraction, 321.
 — phenomena due to, 322-333.
 Reid, 7, 233.
 Richmann, 293.
 Riegenbach, 163.
 Rime, 182.
 Romas, de, 293.
 Rotation of the earth, 40.
 — — effect of, 131.
 Rotch, A. Lawrence, 10, 257.
 Royal Charter Storm, 9.
 Russell, S. C., 175.
 Rykatcheff, 214.

S

Sanctorius, 3.
 Sargasso Sea, 91.
 Saturation, 147.
 — pressure, 148.
 Schering, 305.
 Schmidt, 106.

Scintillation, 324.
 Scott, R. H., 10.
 Secondary depression, 224.
 Shaw, Sir Napier, 10, 170, 171, 200, 205, 206, 213, 216, 231, 248, 259, 276, 287, 358, 363.
 Sidi Ali, 5.
 Simoon, 229.
 Simpson, Dr. G. C., 10, 106, 310, 311, 312.
 Simpson's Theory, 313.
 Sinuosities, 224.
 Sirocco, 228.
 Six's Maximum-minimum Thermometer, 63.
 Snow, 192.
 — crystals, 194.
 — perpetual, 195.
 Snowfall distribution, 195.
 — water equivalent of, 194.
 Solar constant, 49.
 Sound, 344.
 — reflection of, 345.
 — refraction of, 345.
 — ranging, 347.
 Southwell, 4.
 Sprung, 10.
 Standard Deviation (S.D.), 21.
 St. Elmo's fire, 314.
 Stoney, Dr. G. J., 333.
 Storm warnings. See GALEs.
 Stevenson screen, 59.
 Stratosphere, 11, 78, 269.
 Sun pillars, 330.
 Sunrise and sunset colours, 340.
 Sunshine Recorder, Campbell-Stokes, 173.
 Sunspots and weather, 375.
 Supercooled waterdrops, 161, 197.
 Supernumerary rainbows, 335.
 Supersaturation, 161.
 Surge, 225.
 Symons, G. J., 190.
 Synchronous charts, 200, 354.
 Synoptic charts, composition of, 356.
 — special, 362.

T

Tangent arcs, 328.
 Taylor, G. I., 178, 179.
 Taylor's relation, 207.
 Temperature, Chapter IV, 54.
 — of air, annual variation of, 73.
 — — diurnal variation of, 66.
 — — effect of latitude and season on, 69.
 — — extremes of, 86.
 — — isanomalies, 86.
 — — reduction to sea-level, 79.
 — — true, 57.
 — — vertical gradient, 77, 267.
 — — in cyclones, 210.
 — of ground, annual and diurnal oscillations of, 88.
 — of lakes, rivers, springs, 93.
 — — laws governing oscillation of, 87.
 — of sea at the bottom, 92.

Temperature of sea, causes of surface variations of, 90.
 — — — surface, 89.
 — scales, 54.
 Temperatures of air, mean, 267.
 Theodolite for pilot balloons, 279.
 Theodorich, 336.
 Thermal Equator, 80.
 Thermograph, 64.
 Thermometer, development of, 55.
 — errors to be avoided in use of, 57.
 — essentials of, 56.
 — solar radiation, 52.
 — various other kinds of, 55-64.
 Thom. See KELLER.
 Thomson, Sir J. J., 306, 307, 317.
 Thunder, audibility of, 347.
 Thunderstorms, 249-255.
 — hail in, 254.
 — rainfall in, 253.
 Tornadoes, 241-243.
 Torricelli, 3, 27, 96.
 Tower of the Winds, 1.
 Trade Winds and Anti-trade Winds, 137-140.
 — — — — cause of, 137
 — — — — limits of, 142.
 Trajectories of air, 210.
 Tropopause, 270.
 Troposphere, 11, 78, 269.
 Trough of a depression, 202.
 Turbulence, clouds due to, 171.
 Twilight, 340.
 — duration of, 341.
 Twinkling, 324.
 — of the planets, 324.
 Typhoons, 233.

U

Under-cutting of warm air by cold, 245, 247.
 Upper air, humidity of, 154, 157.
 — — investigation of, Chapter VIII, 256.
 — — temperature gradient of, 267.
 — — wind variations in, 278, 285-287.
 Utility of meteorology in peace, 12.
 — — war, 13.

V

Valley frosts, 182.
 — mists, 180.
 Value, educational, 14.
 Values, mean, 18.
 Vane, wind, 118,
 Varenius, 232.
 Vegard, 320.
 Venturi, 331.
 Visibility, 16, 370.
 V-shaped depression, 225.

W

Wada, Dr. Y., 4.
 Waterspout, 244.
 Watery or weak sky, 210.
 Weather. See CLIMATE.
 — in anticyclone, 222.
 — — British Isles, 381.
 — — cyclone, 208.
 — maps. See SYNOPTIC CHARTS.
 — notation of Admiral Beaufort, 356.
 — prognostics, 372.
 — types, Abercromby's, 363.
 — — 363-370.
 — — tendency of, to continue, 370.
 Wedge, 224.
 Whipple, F. J. W., 351.
 Whirlwinds, 243.
 Wilson, C. T. R., 35, 307.
 — Professor A., 5, 256.
 Wilson's apparatus, 309.
 — condensation theory, 317.
 Weisner, 183.
 Wind, annual variation of surface, 128.
 — Buys Ballot's Law, 133.
 — cause of, 128.
 — comparison of gradient wind with surface, 205.
 — cyclostrophic, 204.
 — definition of, 117.
 — diurnal variation of surface, 124, 126.
 — general wind circulation, 134.
 — geostrophic, 203.
 — gradient, 204.
 — in anticyclones, 221.
 — — cyclones, 203-208.
 — relation between wind velocity and pressure, 132.
 — Rose, 124.
 — Vane, 118.
 — variation with height, 285-287.
 — velocity, theoretical determination of, 206.
 Winds, abnormal, 356.
 — cause of prevailing westerly, 139.
 — convergent and divergent, 358
 — katabatic, 145.
 — mountain and valley, 145.
 — Tower of the, 1.
 — associated with cyclones and anticyclones, 226-229.

Y

Young, Dr. T., 331, 336.
 Yule's notation, 24.

Z

Zodiacal light, 343.

